

## SEC. 20-326. BUILDING ELEMENTS.

### (a) AWNINGS AND MARQUEES:

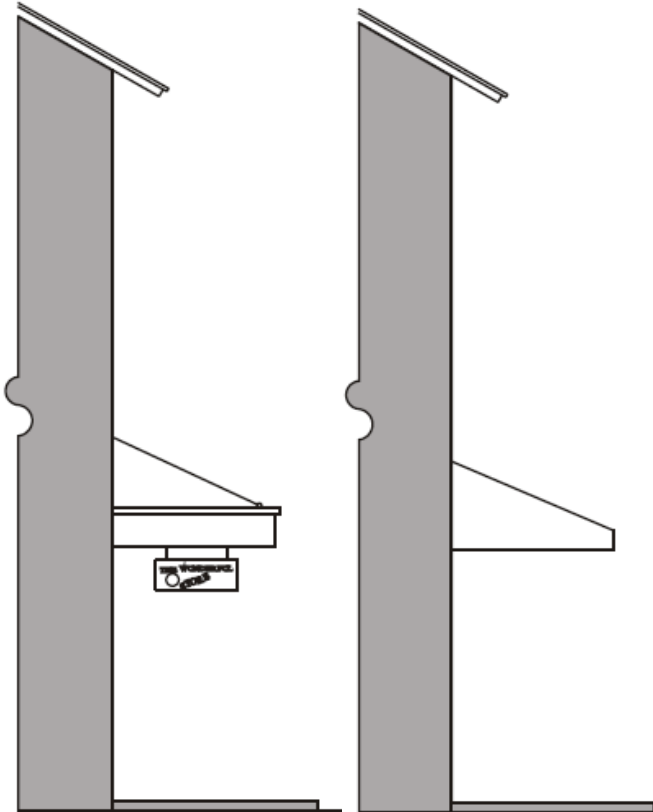

Depth =	5 ft. minimum.
Height =	10 ft. minimum clear.
Length =	25% to 100% of building front.

The above requirements apply to first-floor awnings. There are no minimum requirements for awnings above the first floor.



Additional Example- Winter Park, FL

Marquees and awnings shall occur forward of the build-to line and may encroach within the right-of-way, but shall not extend past the curb line.

Awnings shall be made of fabric. High-gloss or plasticized fabrics are prohibited.



Additional Example- Winter Park, FL



Additional Example- Reston, VA

**(b) BALCONIES:**



*Additional Example- Celebration, FL*

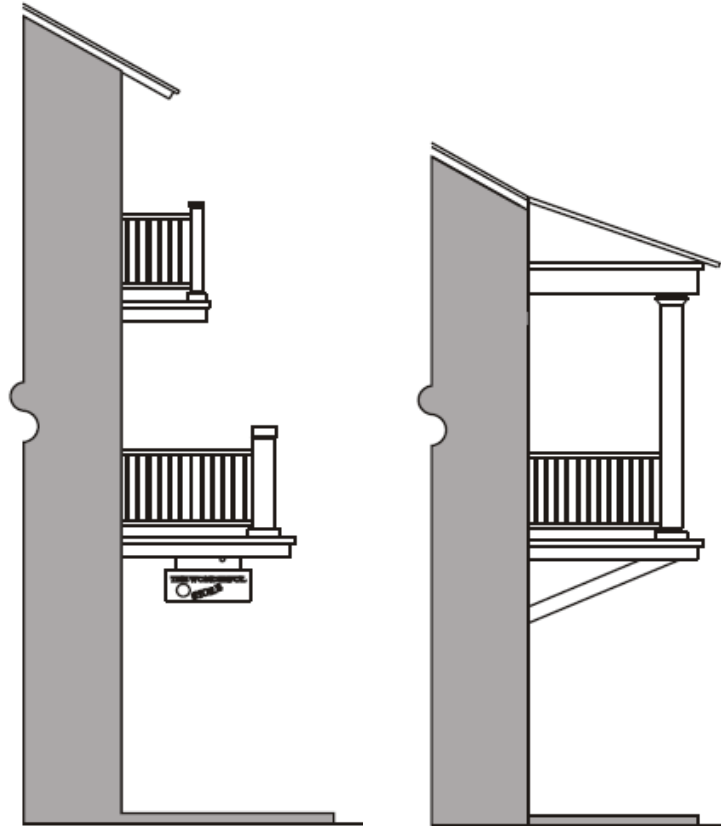

Balconies shall occur forward of the Build-to Line and may encroach within the right-of-way, but shall not extend past the curb line

<i>Depth</i> =	6 ft. minimum for 2nd floor balconies.
<i>Height</i> =	10 ft. minimum clear.
<i>Length</i> =	25% to 100% of building front.



*Additional Example- Seaside, FL*

Balconies may have roofs, but are required to be open, un-airconditioned parts of the buildings.

On corners, balconies may wrap around the side of the building facing the side street.



*Tuskawilla Road Balconies; Winter Springs Town Center*

**(c) COLONNADES/ARCADES:**

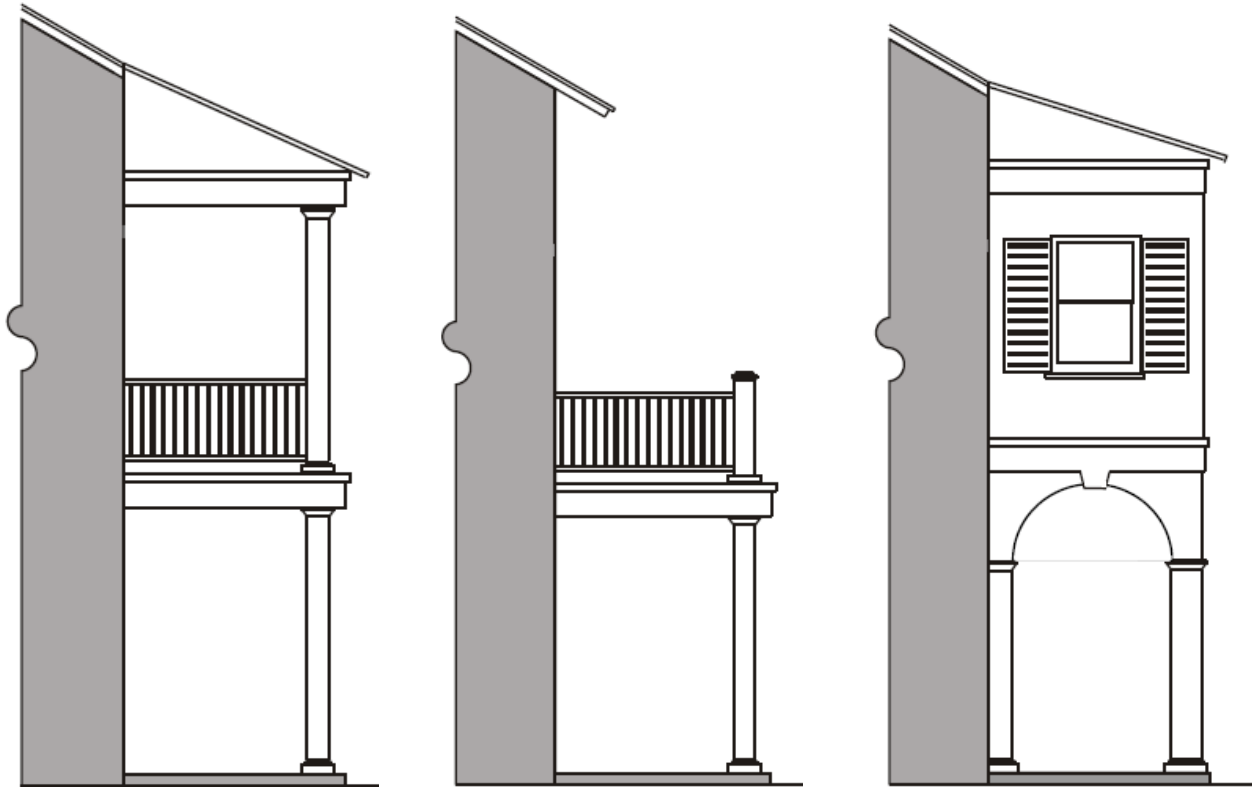

Open multi-story verandas, awnings, balconies, and enclosed useable space shall be permitted above the colonnade.

Depth =	10 ft. minimum from the build-to line to the inside column face.
Height =	10 ft. minimum clear.
Length =	75--100% of building front.

Colonnades shall only be constructed where the minimum depth can be obtained. Colonnades shall occur forward of the Build-to Line and may encroach within the right-of-way, but shall not extend past the curb line. On corners, colonnades may wrap around the side of the building facing the side street.



Additional Example- CityPlace; West Palm Beach, FL



Tuskawilla Road Colonnade  
Winter Springs Town Center

**(d) FRONT PORCHES:**

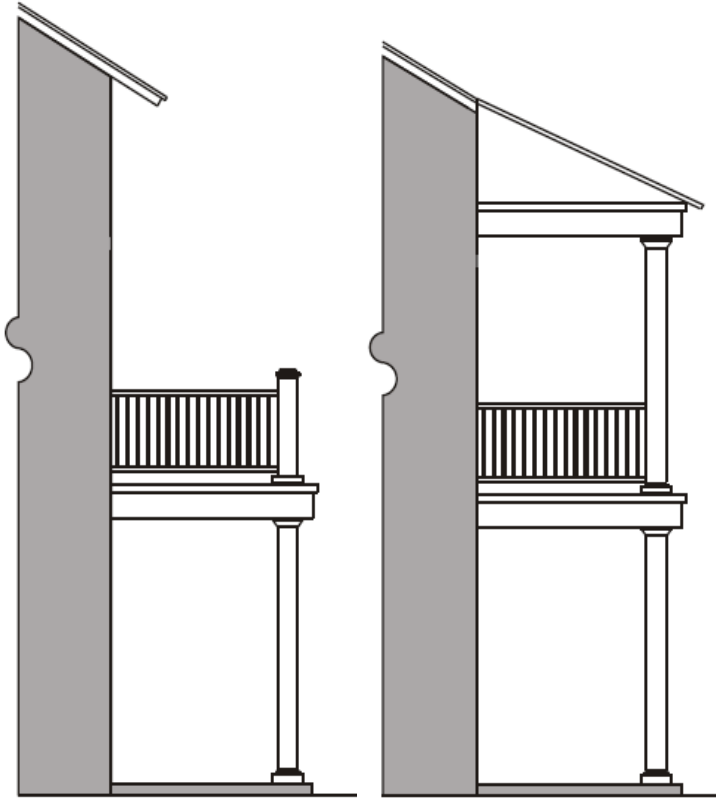

Depth =	8 ft. minimum.
Length =	25% to 90% of building front.

Front porches are required to be open, un-airconditioned parts of the buildings. More than 25% of the floor area of a porch shall not be screened if the porch extends forward of the build-to line.



*Additional Example- Haile Plantation; Gainesville, FL*

Front porches may have multi-story verandas and/or balconies above.

Front porches shall occur forward of the build-to line. Porches shall not extend into the right-of-way.



*Additional Examples- "Eyes on the Street"; Nantucket, MA and Estate Home in Baldwin Park; Orlando, FL*

(e) **STOOPS:**

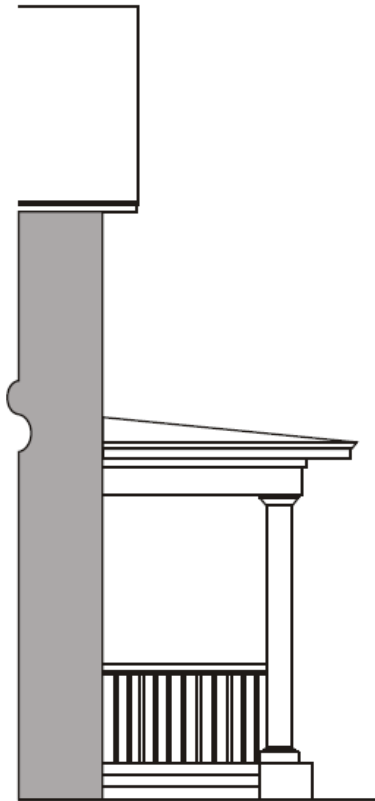

*Additional Example- Savannah, GA*

Stoops are permitted and may occur forward of the Build-to Line. Stoops may encroach within the right-of-way with approval. Sidewalks shall have clear access for pedestrians. Stoops may be covered or uncovered.

Depth =	6 ft. minimum
Length =	5 ft. minimum



*Additional Example- Baldwin Park; Orlando, FL*



*Additional Example- Nantucket, MA*