



City of Winter Springs
Decorative Street Sign Standard
Revised 12/22/10



Decorative Street Sign Program

Basic street signs located within Winter Springs along public roadways are maintained by the City, County or State as a requirement for proper traffic management. The Florida Department of Transportation has minimum requirements for all street signs located along public roadways in the State of Florida.

Upgrading from basic street signs to decorative street signs is an option that may be appealing to groups such as Home Owners Associations, Neighborhoods or Commercial Property Owners. Where proposed street sign upgrades are located along public streets, or on public property, groups wishing to upgrade their street signs are required to execute a Neighborhood Street Sign and Light Improvement Agreement with the City.

In the Town Center District, decorative street signs are required along roadways as part of the Decorative Street Sign and Light Program for new development including: subdivisions, commercial development and areas constructed for public use. Standards for the Town Center District follow the same guidelines as for street signage that is upgraded in all other areas of the City.

Standards for decorative street signs have been established and are outlined in this publication as a guideline for the planning of your project. Additional information is available by contacting the City's Urban Beautification Division at: (407) 327-5976 or by email at: srichart@winterspringsfl.org.

General Requirements:

- **Decorative Street Sign Poles shall be made of 'Extruded Aluminum Alloy' and measured by the Outer Diameter (O.D.) of the pole.**
- **Decorative Street Sign Pole Bases, Finials and Trim shall be made of 'Cast Aluminum Alloy'.**
- **All Decorative Street Signage parts and materials shall be finished in 'Powder Coated - Black'.**
- **All street signs and sign plates shall be in 'High Density' signage on the finish side and 'Power Coated - Black' on the back side.**





- **All Decorative Street Signs and parts shall comply with Florida Department of Transportation requirements for roadway signage.**
- **Technical Requirements for Decorative Street Signs are shown in the Cut Sheets / Specifications Section of this document and must be followed when specifying and installing your project.**

City of Winter Springs
Decorative Street Sign Standard

Assembled Sign Examples





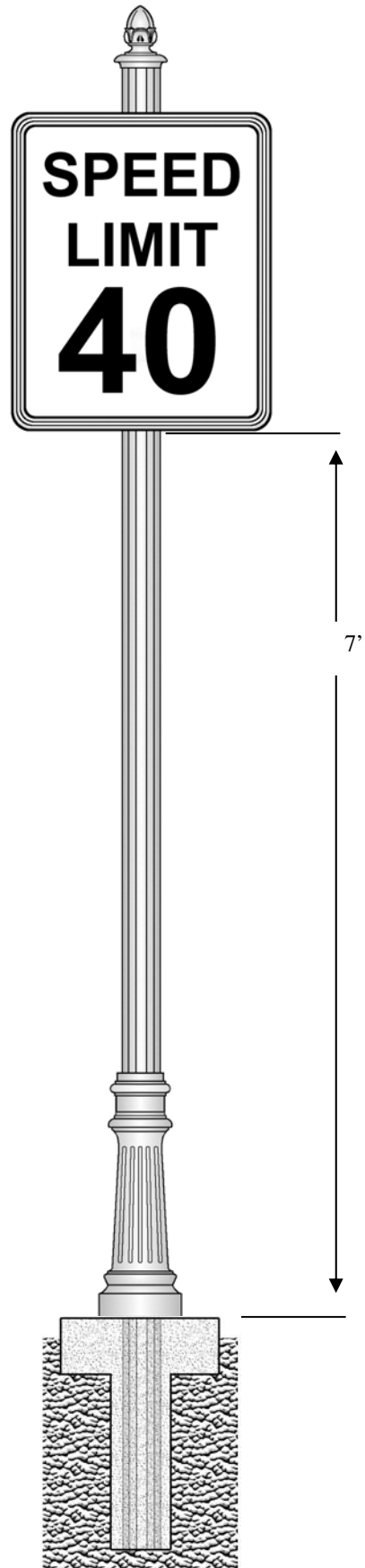

THIS SIGN MADE FROM THE PARTS BELOW:

4" X 12'8" Fluted pole Extruded Aluminum .0125 Wall Thickness	
Slipover Base For 4" Pole Cast Aluminum	
Acorn Finial For 4" Pole Cast Aluminum	
Trim For 24" x 30" Traffic Sign Cast Aluminum	
Reflective 24" x 30" Speed Sign Specify Vinyl Type	







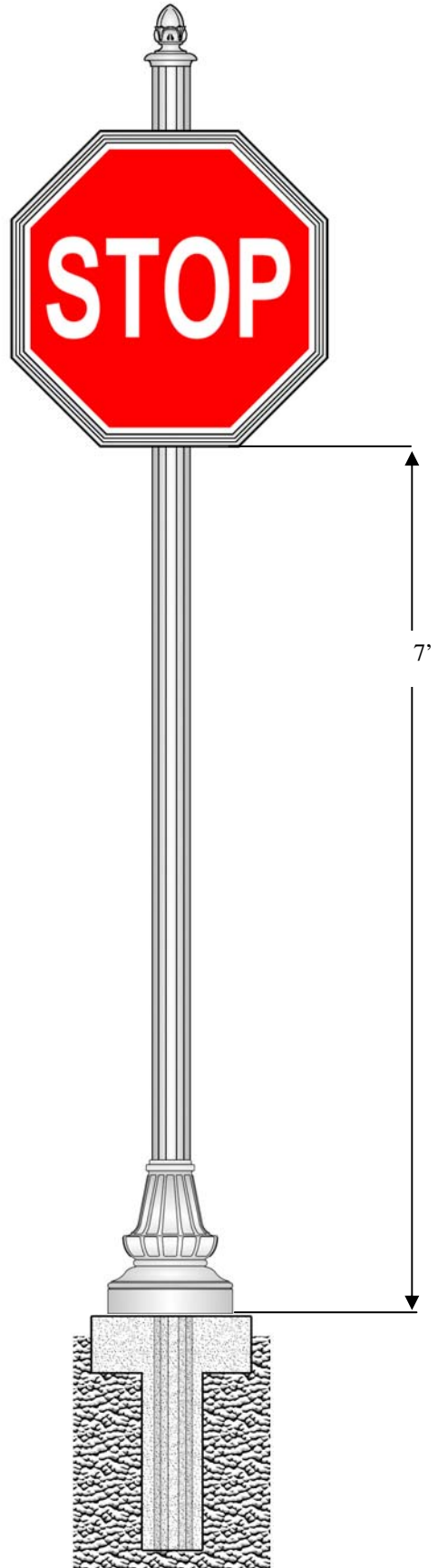



THIS SIGN MADE FROM THE PARTS BELOW:

<p>4" X 12'8" Fluted pole Extruded Aluminum .0125 Wall Thickness</p>	
<p>Base For 4" Pole Cast Aluminum</p>	
<p>Acorn Finial For 4" Pole Cast Aluminum</p>	
<p>Trim For 30" Stop Sign Cast Aluminum</p>	
<p>Reflective 30" Stop Sign Specify Vinyl Type</p>	





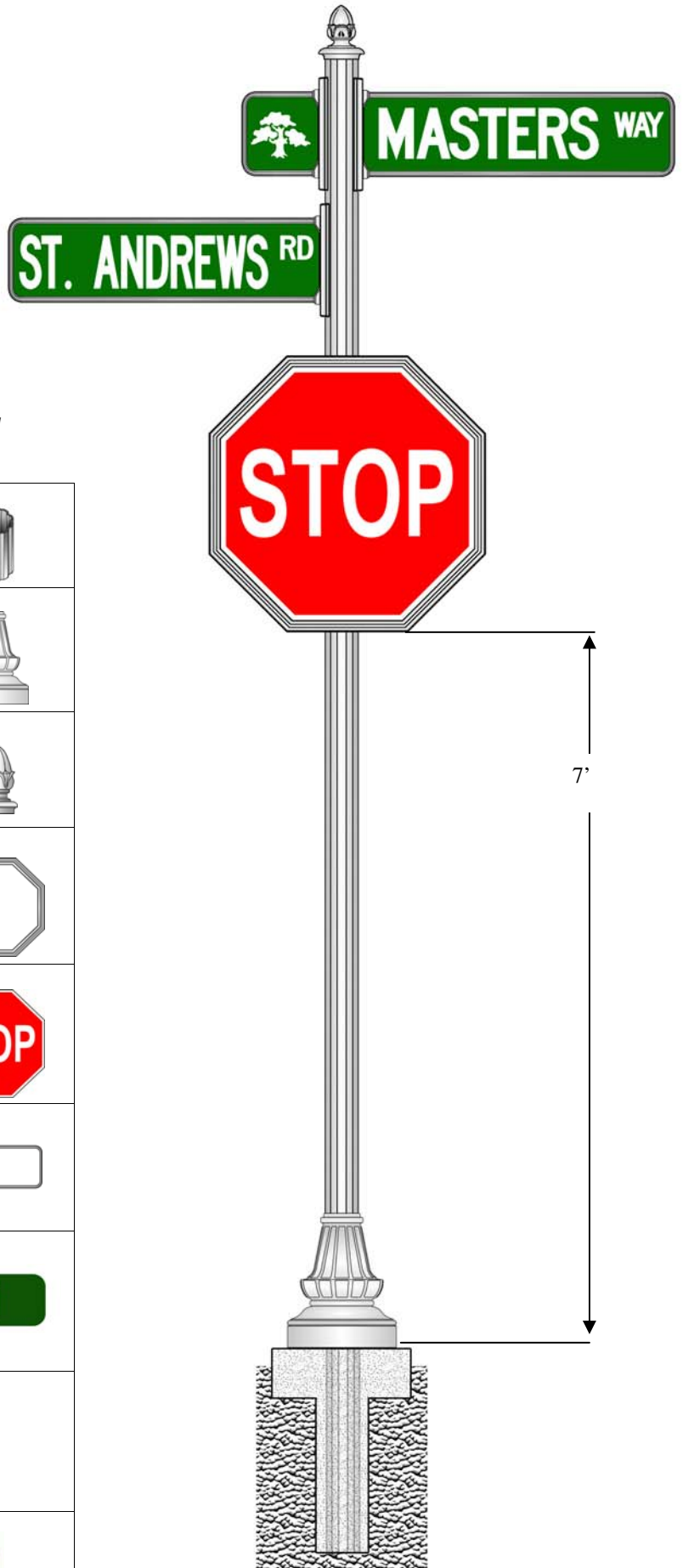

THIS SIGN MADE FROM THE PARTS BELOW:

4" X 14' Fluted pole Extruded Aluminum .0125 Wall Thickness	
Base For 4" Pole Cast Aluminum	
Acorn Finial For 4" Pole Cast Aluminum	
Trim For 30" Stop Sign Cast Aluminum	
Reflective 30" Stop Sign Specify Vinyl Type	
Trim For 9" x 36" Street Sign Extruded and Cast Aluminum	
9" x 36" Reflective Street Sign Specify Vinyl Type	
For 9" x 9" Logo Sign Extruded and Cast Aluminum	
9" x 9" Optional Logo sign	





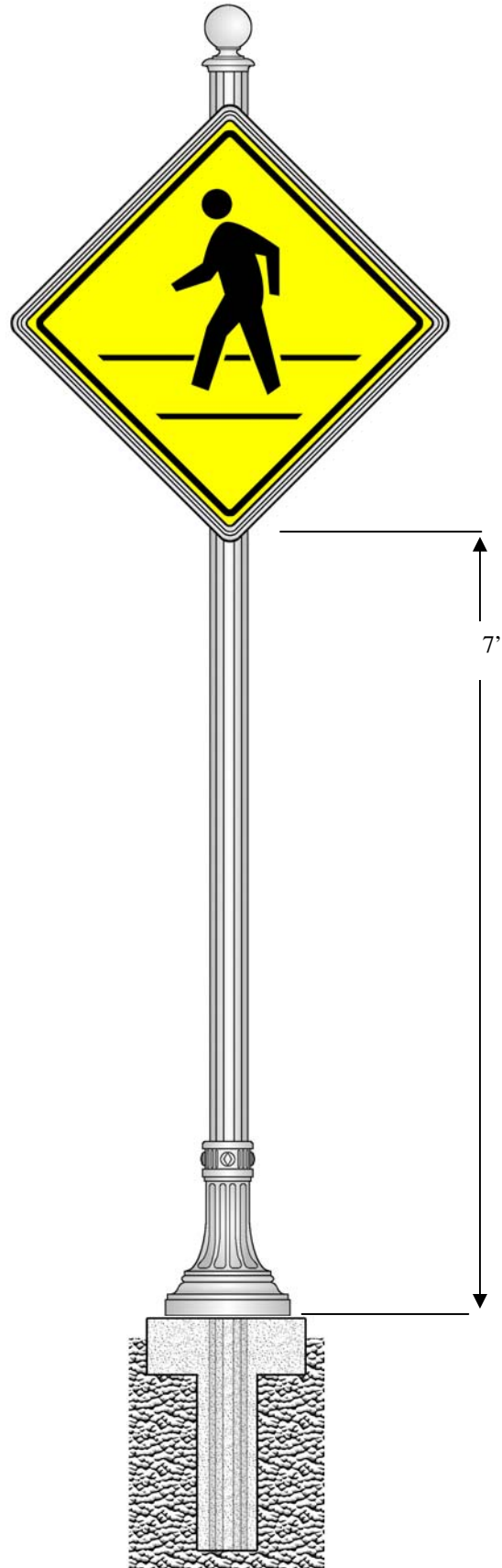

THIS SIGN MADE FROM THE PARTS BELOW:

4" X 12'8" Fluted pole Extruded Aluminum .0125 Wall Thickness	
Base For 4" Pole Cast Aluminum	
Ball Finial For 4" Pole Cast Aluminum	
Trim For 30" Diamond Traffic Sign Cast Aluminum	
Reflective 30" Pedestrian Crossing Sign Specify Vinyl Type	



THIS SIGN MADE FROM THE PARTS BELOW:

4" X 12'8" Fluted pole Extruded Aluminum .0125 Wall Thickness	
2 Piece Base For 4" Pole Cast Aluminum	
Acorn Finial For 4" Pole Cast Aluminum	
Trim For 36" Yield Sign Cast Aluminum	
Reflective 36" Yield Sign Specify Vinyl Type	

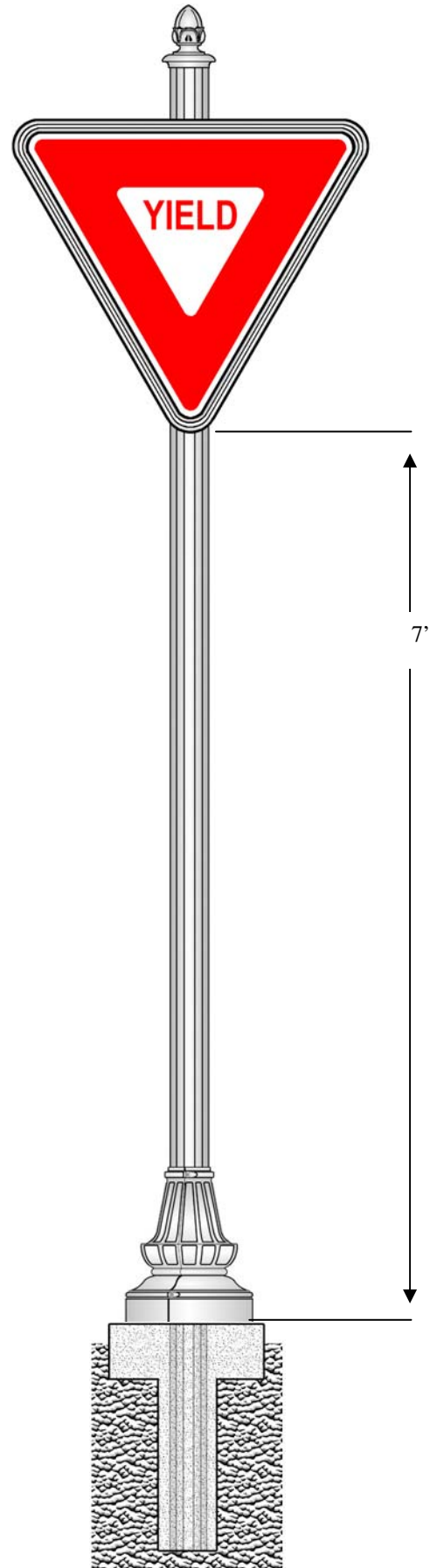

City of Winter Springs
Decorative Street Sign Standard

Installation Instructions



Sign Pole Installation Instructions

Before placing your order you need to contact the City of Winter Springs about all applicable ordinances and codes to make sure that the installation will comply. The clearance height to the bottom of the lowest sign is 7 feet. Your location may have additional requirements and specifications with regard to sign dimensions, vinyl types and more.

Before you begin your installation you must call in utility locates through **Sunshine State One Call** by dialing 811 from a phone. Wait the required amount of time for them to survey. Respect the locate marks and dig with care. Failing to do so may result in property damage, injury or even death.

1. Sign Pole Installation
2. Dig your hole a minimum of 1' in diameter and 3' deep, according to local codes and soil conditions.
3. Insert the pole with the holes or channels properly aligned with the roadway.
4. Level and brace the pole in place.
5. Create a form for the cement footing to be slightly above grade. This will serve to protect the finish of the pole from soil and lawn equipment. See Example A
6. Fill the hole with cement according to manufacturer's instructions.
7. Recheck with level and adjust as needed.*
8. Return after the concrete is sufficiently cured to install signs and other components to the pole.

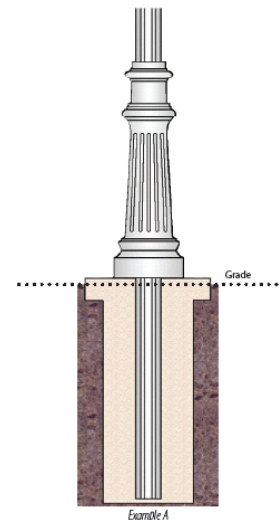

NOTE: At this time it may be wise to install regulatory signs such as **STOP signs and **YIELD signs** as a matter of public safety.** Weather conditions may dictate that other components not be installed until after the cement has had time to cure. When work is completed, the completed project must be inspected and accepted by the City.

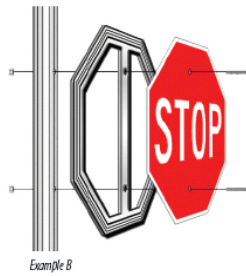

Fluted Sign Pole and Smooth Sign Pole installations require holes to be drilled for mounting the signs, trims and brackets. Be sure to include the thickness of the sign trim when determining the clearance height of the lowest sign. When using a hand drill it is recommended that the holes be measured and drilled from each side of the pole for better alignment.

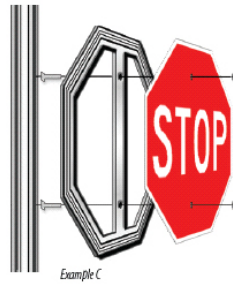

Channel Sign Pole (Patent Pending) installations do not require drilling. Traffic signs and trims are attached to a channel by sliding the nut or bolt into the channel and tightening.

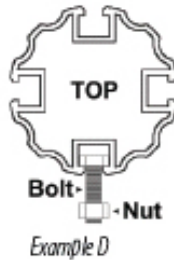

Installing Street Sign Blades Into Sign Trims

Slide Double-sided street sign into trim and use set screw to hold into place.



City of Winter Springs
Decorative Street Sign Standard

Cut Sheets / Specifications



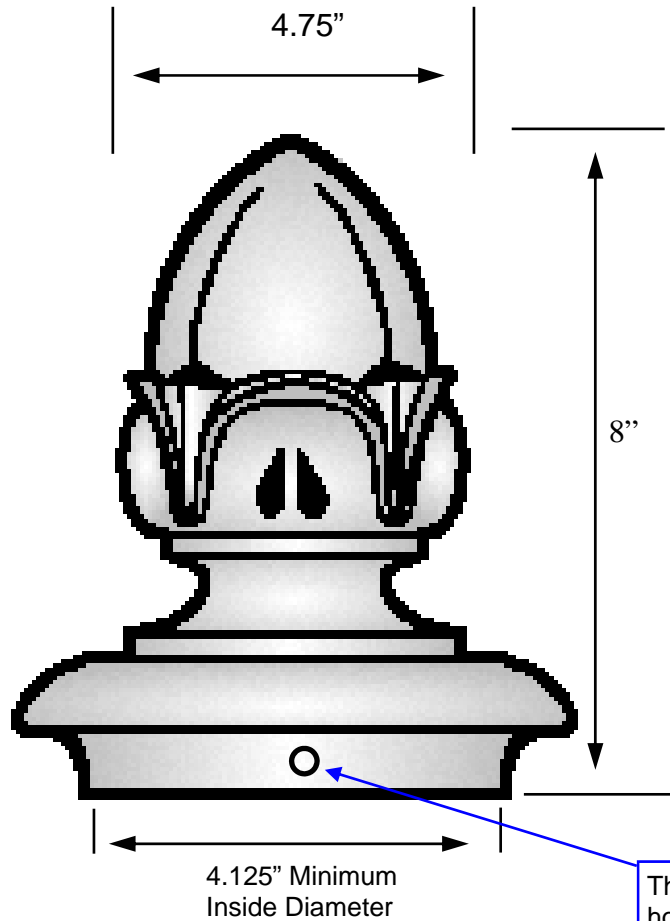

Acorn Finial for 4" OD pole
Cast Aluminum Alloy

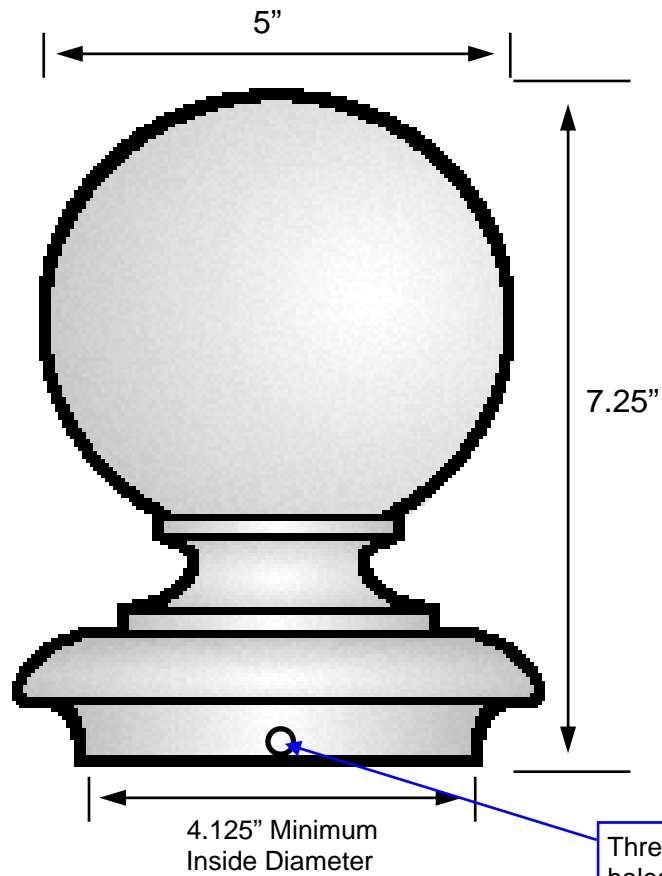

Three 5/16-18 threaded holes at 120° intervals to set screw against 4" OD pole

Ball Finial for 4" OD pole
Cast Aluminum Alloy

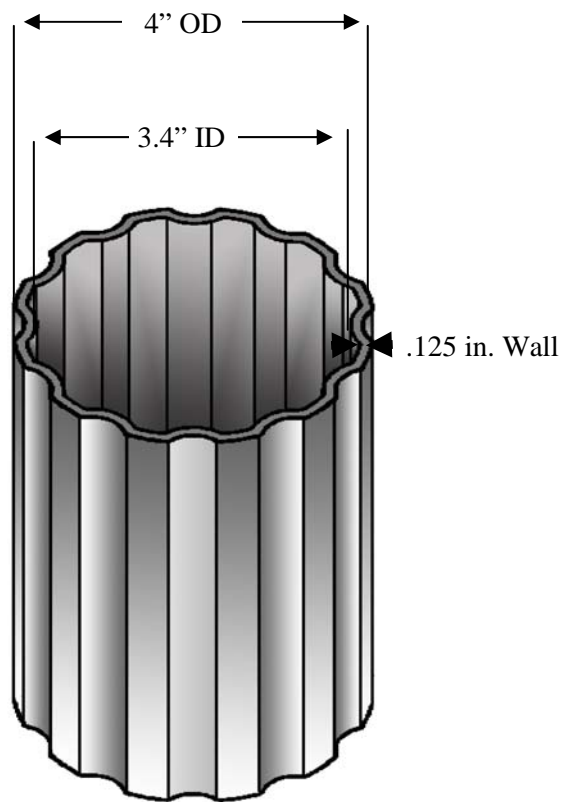

4" OD Fluted Pole
Extruded Aluminum Alloy

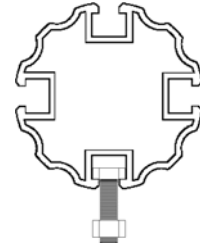

Top View

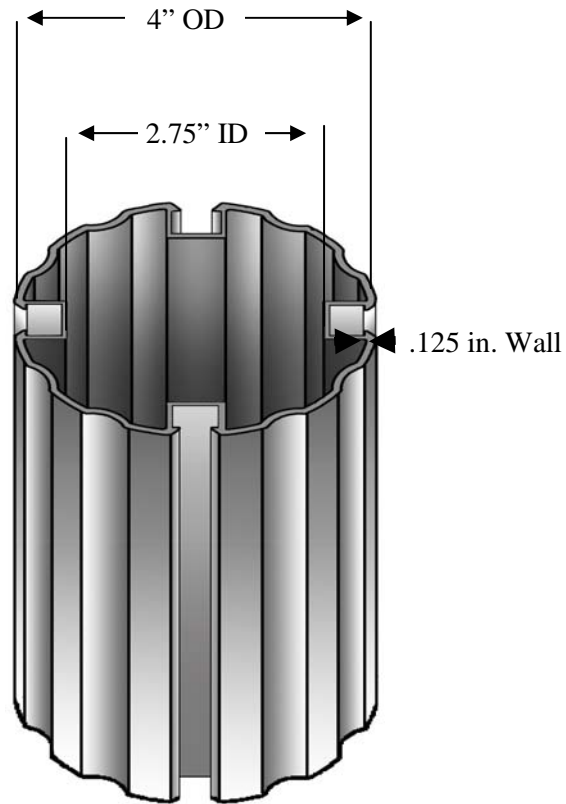

4" OD Fluted Channel Pole
Extruded Aluminum Alloy

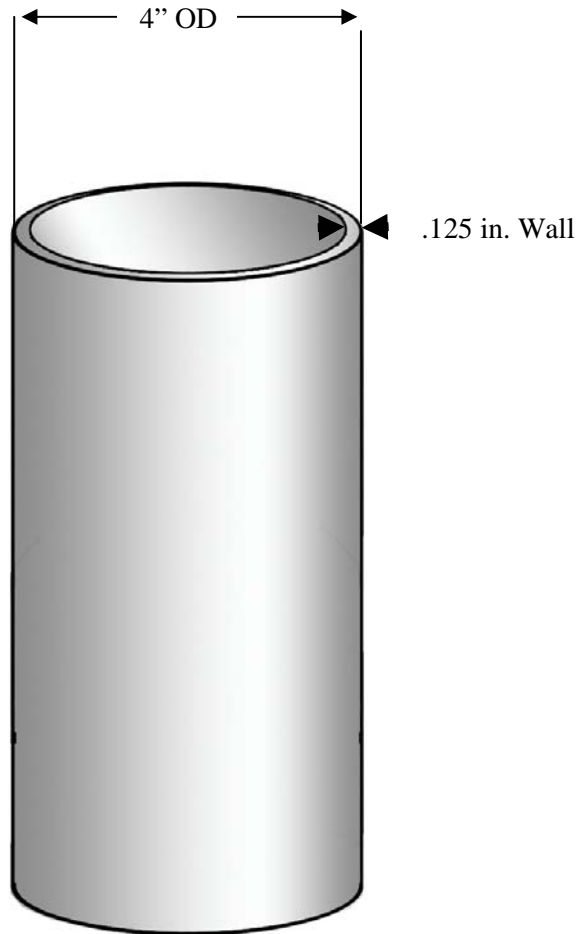

4" OD Smooth Pole
Extruded Aluminum Alloy

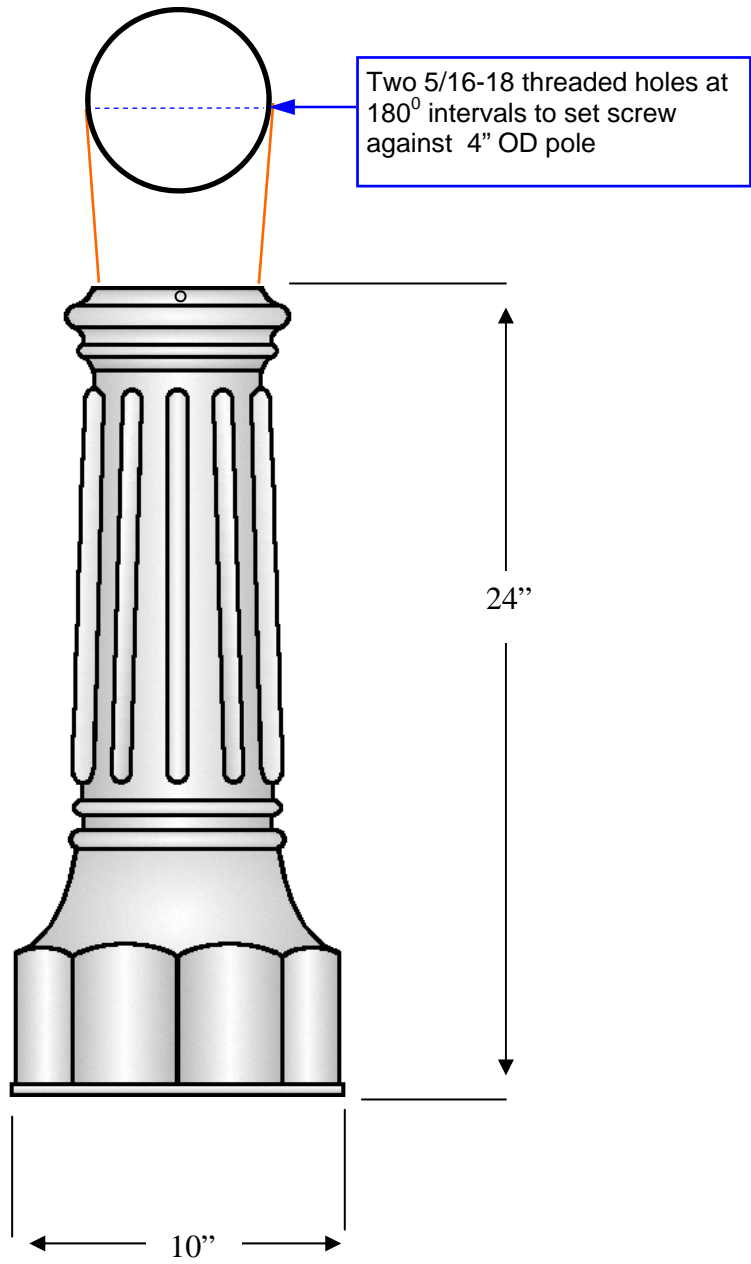

2 Piece Base - For 4" OD Pole
Clamshells around pole
Cast Aluminum Alloy

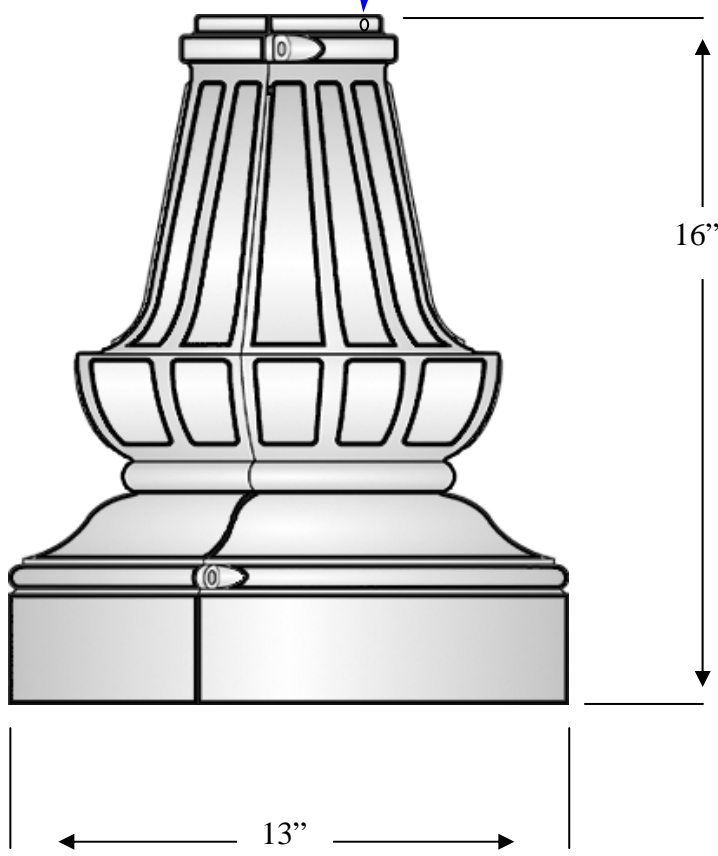
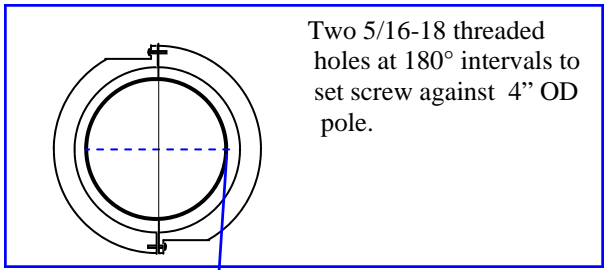

2 Piece Base for 4" OD pole
Clamshells around pole
Cast Aluminum Alloy

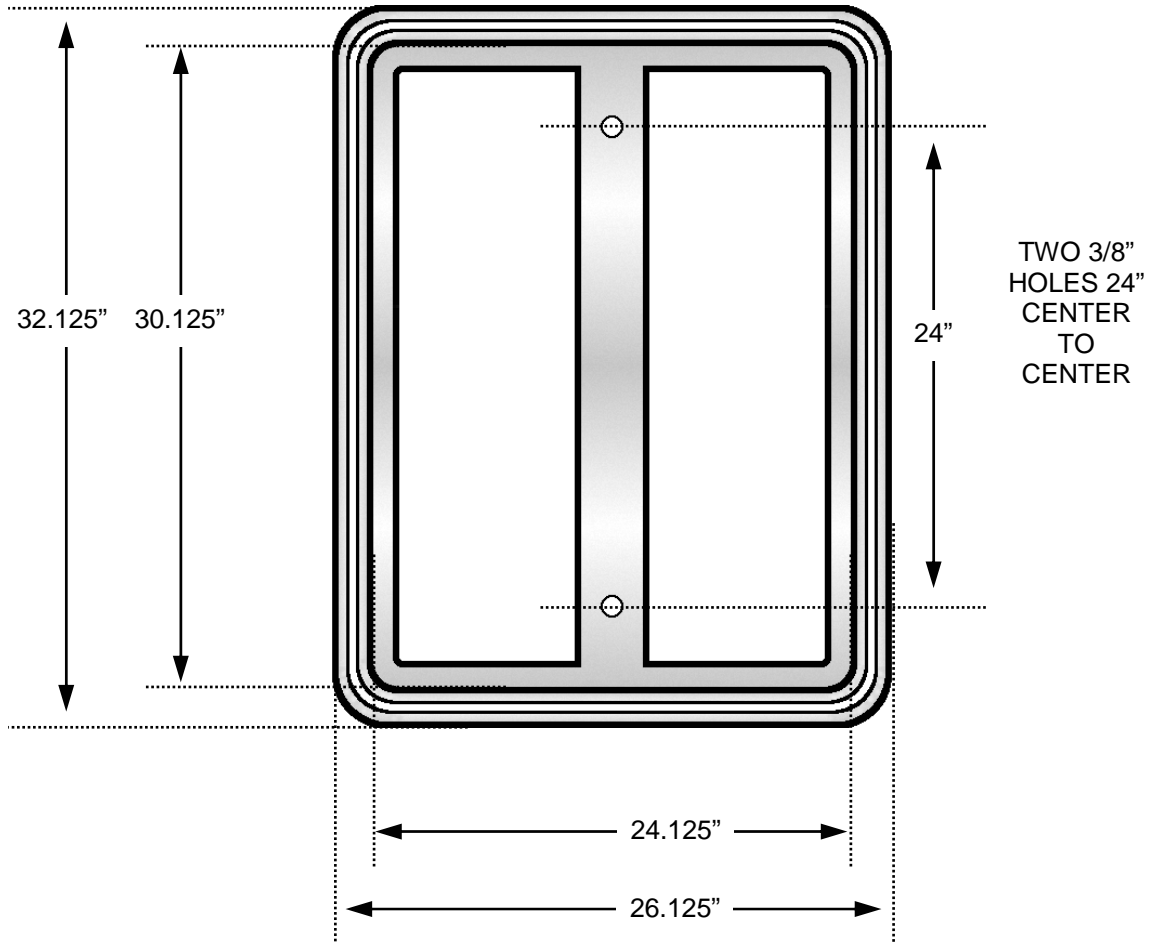

Trim for 24" X30" Sign
Cast Aluminum Alloy

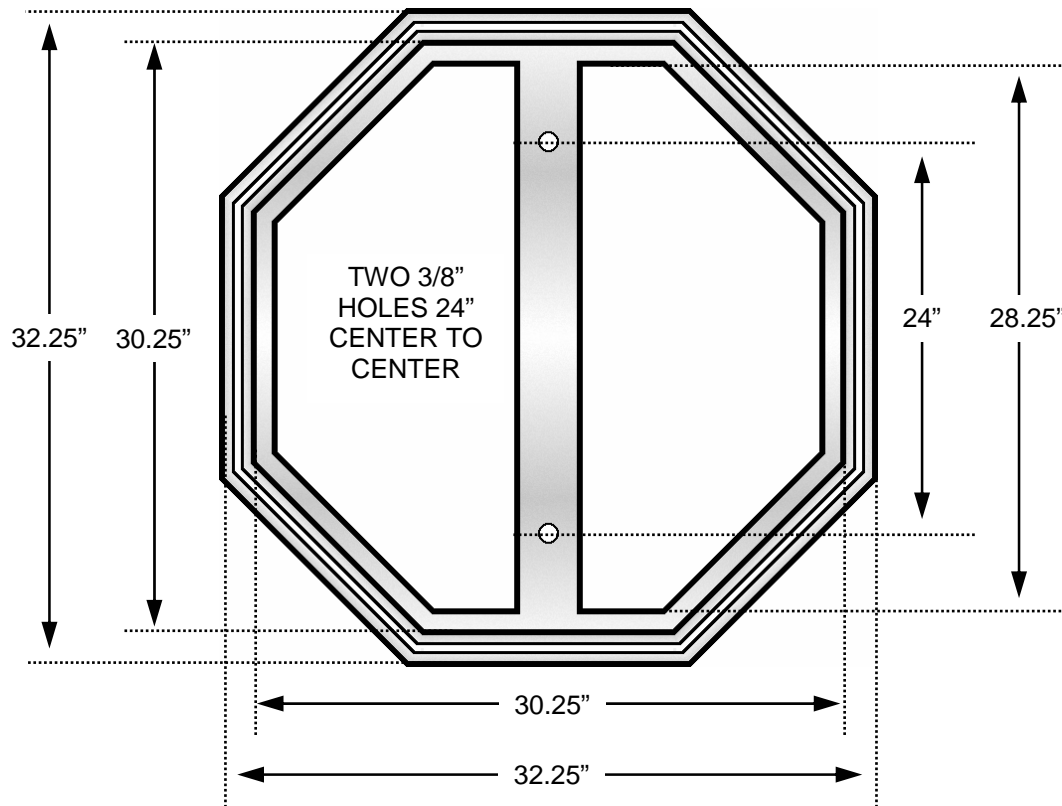

Trim for 30" Stop Sign
Cast Aluminum Alloy

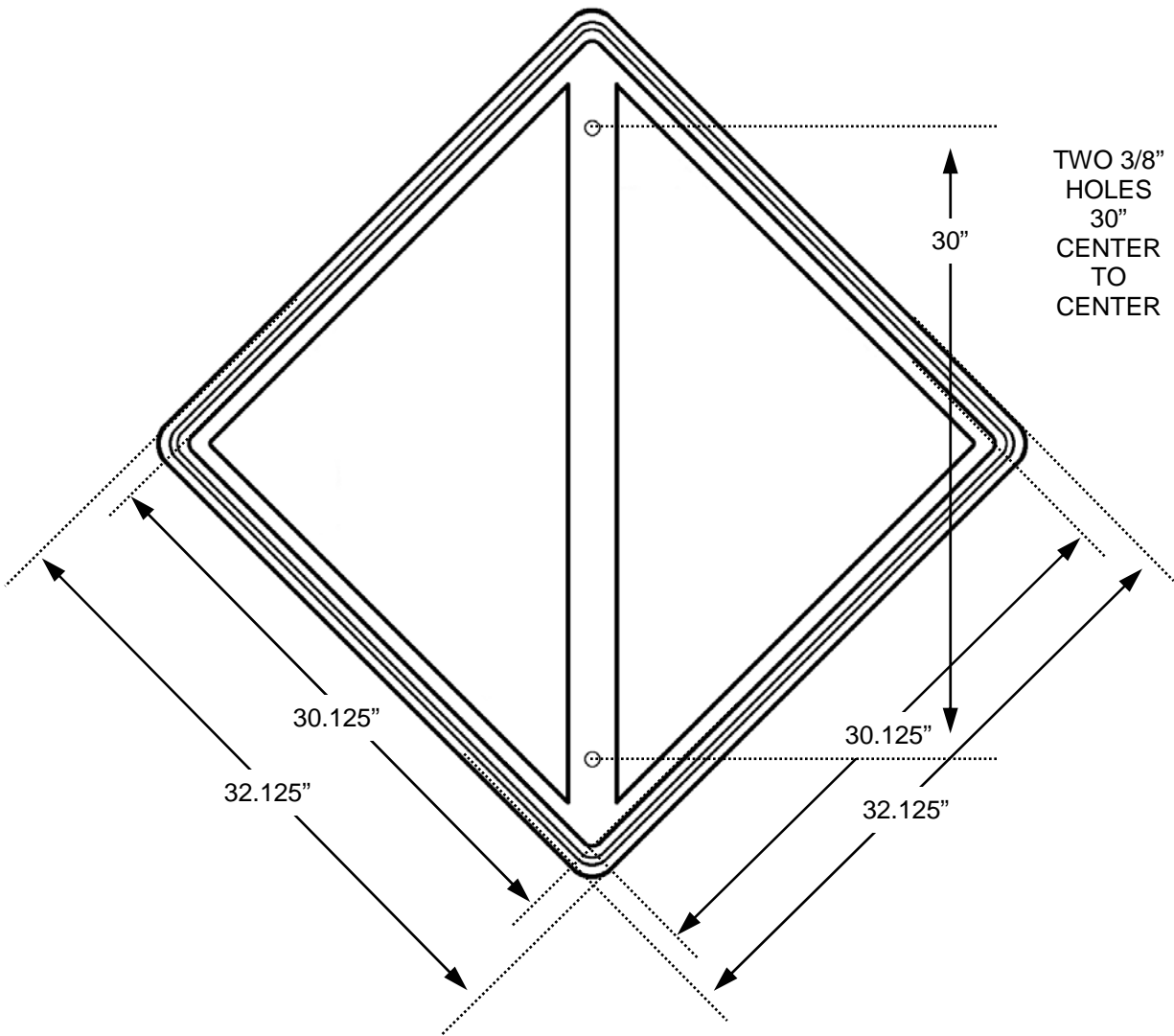

Trim for 30" X30" DiamondSign
 Cast Aluminum Alloy

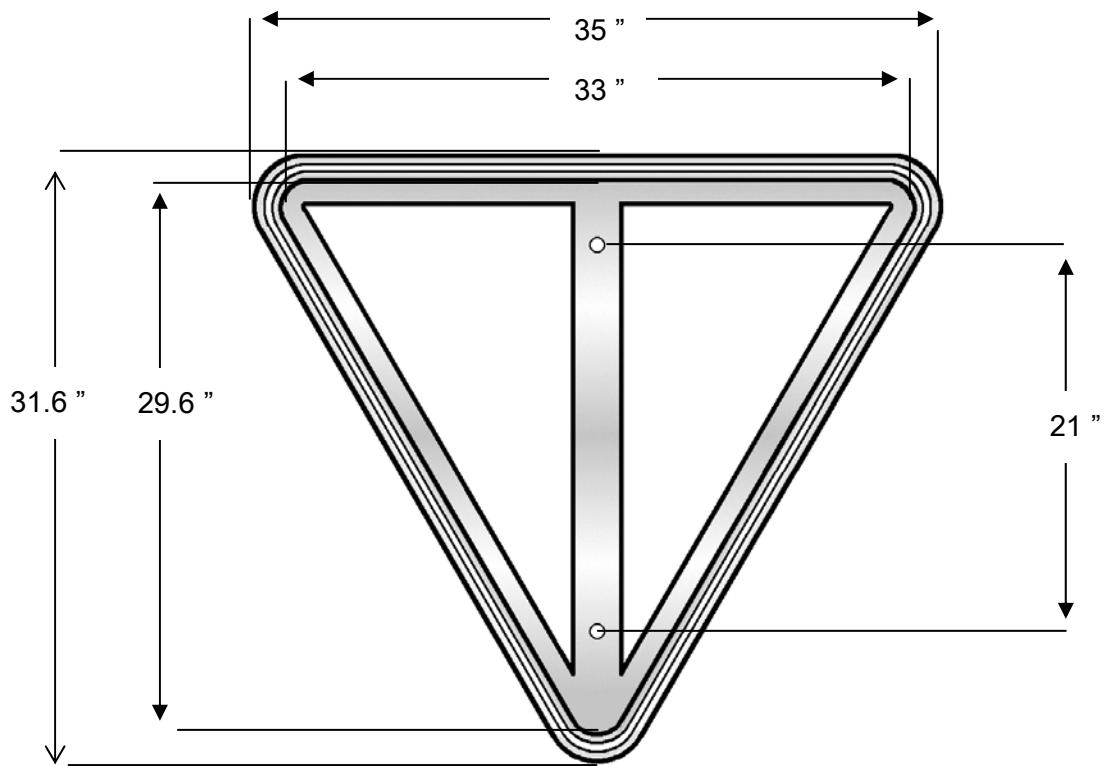

Trim for 36" Yield Sign
Cast Aluminum Alloy

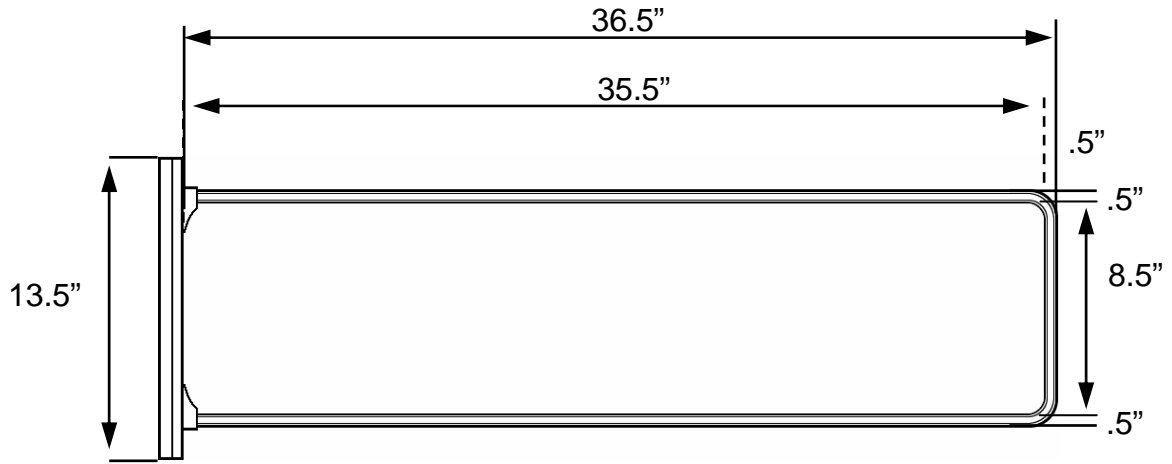

BACK VIEW

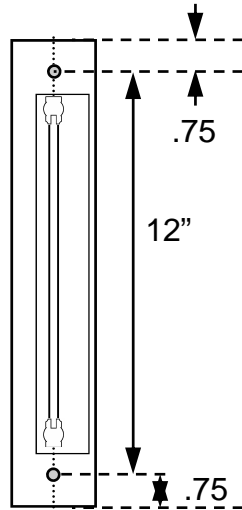

Sign Trim for 9" X 36" Street Sign
 Cast Aluminum Back Plate Alloy
 Extruded Frame Alloy

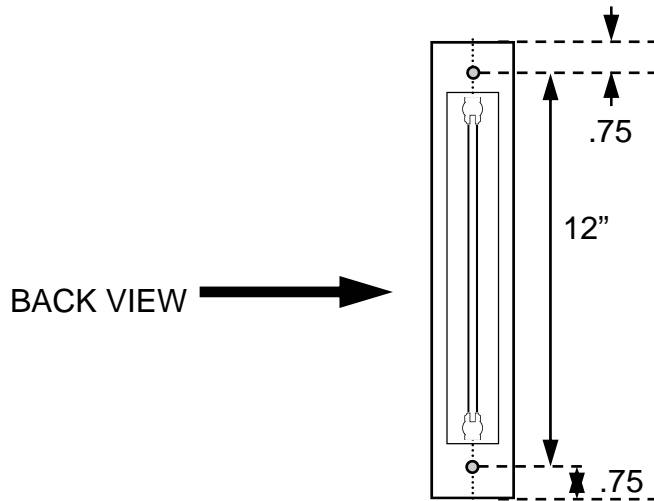
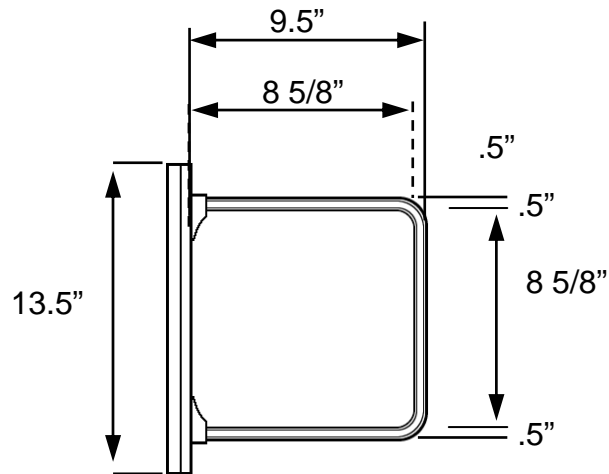

Trim for 9" X 9" Logo Sign
 Cast Aluminum Back Plate Alloy
 Extruded Frame Alloy

City of Winter Springs
Decorative Street Sign Standard

**Neighborhood Street Sign and
Light Improvement Agreement
(NSSLIA)**



**NEIGHBORHOOD STREET SIGN AND LIGHT
IMPROVEMENT AGREEMENT**

This Neighborhood Street Sign and Light Improvement Agreement (“Agreement”) is made and entered into this ____ day of _____, 20____, by and between the **City of Winter Springs**, Florida, a Florida municipal corporation (“City”) and _____, (**Developer**), a Florida corporation (“Association”).

WITNESSETH:

WHEREAS, the Association is a community or homeowner’s Association located within the City of Winter Springs, Florida; and

WHEREAS, the City provides the Association and its members with standard street signs and standard street lights located on City streets that traverse through the real property which constitutes the Association; and

WHEREAS, the Association and the City desire to provide enhanced decorative street signs and decorative street lights at the Association’s expense under the terms and conditions herein; and

WHEREAS, the parties acknowledge that this agreement will improve the aesthetic appearance of the City’s streets primarily for benefit and enjoyment of the Association and its members and incidentally to the rest of the citizens of Winter Springs.

NOW THEREFORE, in consideration of the mutual promises set forth hereunder, and other good and valuable consideration, which the parties acknowledge has been exchanged, the parties agree as follows:

Section 1. Recitals. The foregoing recitals are true and correct and are hereby incorporated herein as a material part of this Agreement.

Section 2. Definitions. The following words and phrases used herein shall have the following meaning unless the context clearly indicates otherwise:

2.1 **“Progress Energy”** shall mean Progress Energy and any successor and assign to the City’s electric franchise.

2.2 **“Sign Plate”** shall mean the metal face plate of the street sign on which street names and other traffic symbols and/or language is written such as “stop” and speed limits.

2.3 **“Street Light Base Rate”** shall mean the actual cost charged by Progress Energy to maintain and operate a **standard concrete pole and cobra fixture**. Said costs include electric, equipment rental, maintenance, gross receipts tax and other associated charges imposed by Progress Energy in accordance with law. At the effective date of this Agreement, the Street Light Base Rate is equal to \$_____. The parties acknowledge that said base rate is subject to periodic adjustments by Progress Energy and the City of Winter Springs.

Section 3. Scope of Project. The City and the Association agree that this Agreement may cover both decorative street signs and decorative street lights depending on what is specifically set forth in **Exhibit “1”**. The City and Association agree that the Association desires to purchase, install, maintain and operate the decorative street signs and street lights depicted and itemized in **Exhibit “1”**, which is attached hereto and incorporated herein by this reference (the “Project”). The parties acknowledge that if decorative street signs are installed, they must comply with the standards of the Florida Department of Transportation and the City of Winter Springs, and if decorative street lights are installed, they must be provided by Progress Energy and approved by the City of Winter Springs.

Section 4. Association’s Obligations. The Association agrees to perform the following obligations:

4.1 Decorative Street Signs. To the extent that decorative street signs are part of this Agreement as provided on **Exhibit “1”**, the Association agrees to fully cooperate with the City to purchase, install, and maintain (_____) decorative street signs required by the Project as follows:

(A) The Association shall agree to pay the City’s actual out-of-pocket cost of purchasing and installing the decorative street signs required to complete the Project.

(B) Prior to the City purchasing the decorative street sign component of the Project, the Association agrees to provide the City with a deposit in the amount of (_____) Dollars (\$_____) which represents a minimum of one hundred percent (100%) of the estimated cost of the street sign component of the Project, excluding the cost of sign plates.

(C) Within seven (7) days of the City awarding a contract for the street sign component of the Project (“Street Sign Contract”) and prior to contract execution with the contractor, the Association shall pay the City any remaining amount that is due under the Street Sign Contract, if any, less the deposit and excluding the cost of the sign plates. The City reserves the right to terminate the Street Sign Contract should the Association fail to make said payment.

(D) In the event any of the decorative street signs must be replaced or repaired due to damage, deterioration, or age, the Association agrees to pay the City the cost of the repairs or the cost of purchasing and installing the replacement decorative street signs. The Association’s payment shall be made within thirty (30) days of receipt of written notice from the City and prior to the

replacement. Notwithstanding, the City will be responsible for the repair or replacement of any damaged, deteriorated, or aged street sign plate. All other components of the street sign including, but not limited to, the foundation, framing, and pole will be the responsibility of the Association.

(E) During the term of this Agreement, the Association agrees to maintain with the City security for the cost of labor and materials for future sign repairs and replacement. At the Association's election, the security shall be in the form of a letter of credit issued from a solvent bank with a branch office in the Central Florida area, a payment bond issued from a highly rated surety in the amount of ten percent (10%) of the Street Sign Contract, or the advance purchase of _____ decorative street signs which will be stored as inventory by the City for future sign repairs and replacement. If elected, said bank or surety, and the form of the letter of credit or bond, shall be subject to the City's approval prior to issuance. The City reserves the right to periodically adjust the required amount of the letter of credit or bond for inflation or require additional advance purchases of decorative street signs to replace depleted inventory. In the event the letter of credit or bond is not replaced upon expiration, the City shall notify the Association in writing that the letter of credit or bond must be replaced to satisfy the requirements of this Agreement. Upon receipt of said notice, the Association shall have fifteen (15) days in which to replace the letter of credit or bond. The City shall have the right to call the letter of credit or bond to repair or replace any street sign required by this Agreement or to purchase and install any additional decorative street signs that the City determines are needed for traffic safety purposes within the Association property. In the event that a street sign must be replaced, repaired, or added and the Association has failed to maintain the letter of credit or bond or maintain an inventory of replacement decorative street signs, the City shall have the unconditional right to make said repairs, replacement, or addition using a standard non-decorative street sign and recover the actual cost thereof from the Association.

4.2 Decorative Street Lights. To the extent that decorative street lights are part of this Agreement as provided on **Exhibit "1"**, the Association agrees to fully cooperate with the City to acquire, install, maintain, and operate _____ decorative street lights required by the Project as follows:

(A) The Association shall assume the full responsibility of maintaining the Progress Energy invoice for all of the street lights covered by the Project, including having the account placed in the name of the Association and making prompt and timely payments on said account.

(B) The Association shall be responsible for promptly reporting all broken or damaged street lights directly to Progress Energy. The City reserves the right to do the same in the event that the Association fails in said reporting responsibilities.

Section 5. City's Obligations. Subject to the Association's compliance with its payment responsibilities set forth under this Agreement, the City agrees to perform the following obligations:

5.1 The City agrees to pay the cost of purchasing replacement Sign Plates required for the Project.

5.2 The City will purchase replacement decorative street signs required by the Project and under the Street Sign Contract in accordance with the City's purchasing policies and procedures.

5.3 The City will assist the Association in coordinating with Progress Energy to acquire and install the decorative street lights. Upon installation and the establishment of an account with Progress Energy, the City agrees to reimburse the Association for the maintenance and operation of the decorative street lights in an amount equal and strictly limited to the Street Light Base Rate. The City shall make the reimbursement on a quarterly basis. However, with respect to any increase in the number of street lights above the number that were actually installed for the Association at the effective date of this Agreement, the City shall not be responsible for the Street Light Base Rate for the additional street lights unless the City agrees, in its discretion, that the additional light(s) were required to bring the Association's street light plan into conformance with Progress Energy's standard photometric requirements.

Section 6. Title to Street Signs and Lights. The right, title and interest of the decorative street signs shall be vested in the City. The right, title and interest of the decorative street lights shall be vested in Progress Energy. The Association shall have no property interest in the decorative street signs and street lights.

Section 7. Applicable Law; Venue. This Agreement shall be governed by and construed in accordance with the laws of the State of Florida and the Winter Springs Code. The parties agree that venue shall be exclusively within Seminole County, Florida, for all state disputes or actions which arise out of or are based upon this Agreement, and in Orlando, Florida, for all such federal disputes or actions.

Section 8. Amendments. This Agreement shall not be modified or amended except by written agreement executed by all parties hereto and approved by the City Commission or City Manager of the City of Winter Springs.

Section 9. Entire Agreement; Headings. This Agreement contains the entire agreement between the parties as to the subject matter hereof. The Agreement may only bind the City if executed by the City Manager or Mayor of Winter Springs. Paragraph headings are for convenience of the parties only and are not to be construed as part of this Agreement. All references to whole paragraph numbers (e.g. 2) shall include all subparagraphs thereunder (e.g., 2.1).

Section 10. Severability. If any provision of this Agreement shall be held to be invalid or unenforceable to any extent by a court of competent jurisdiction, the City shall have the unconditional right to either terminate this Agreement, modify this Agreement with the Association's consent, or remain in the Agreement as modified by the court.

Section 11. Sovereign Immunity. Nothing contained in this Agreement shall be construed as a waiver of the City's right to sovereign immunity under Section 768.28, Florida Statutes, or any other limitation on the City's potential liability under state or federal law. Said rights and limitations shall be deemed fully incorporated herein by this reference.

Section 12. Notice. All notices and correspondence in connection with this Agreement must be in writing. Notice and correspondence shall be sent by first class mail or hand delivered at the addresses set forth below or at such other addresses as the parties hereto shall designate to each other in writing.

(a) If to the City:

**City Manager
City of Winter Springs
1126 East State Road 434
Winter Springs, FL 32708-2799
407-327-1800 x 202 (Phone)
407-327-6695 (Fax)**

(b) If to the Association:

Section 13. Waiver Any forbearance by the City in exercising any right or remedy under this Agreement shall not constitute a waiver of or preclude the exercise of any right or remedy.

Section 14. City's Right to Seek Equitable Relief and Special Assessment. The Association agrees, acknowledges and recognizes that any breach of this Agreement by the Association may result in irreparable harm to the City. The Association agrees that in addition to and not in lieu of all legal and equitable remedies available to City by reason of such breach, City shall be entitled to equitable relief (including, without limitation, specific performance and injunctive relief) to enjoin the occurrence and condition of the breach. Further, in the event the Association fails to make any payments that are required herein, the Association acknowledges and agrees that the decorative street signs and street lights provide a special benefit to the Association and its members and that said special benefit is shared proportionately by all the members of the Association. In the event that the City determines that the Association has not made the payments required by this Agreement, the City reserves the unconditional right to assess the Association and its members for the Association's costs for the decorative street signs and street lights. In the event the City is required to initiate an assessment, the Association agrees to fully support the assessment

and the Association shall not contest, challenge or intervene in the assessment process. Further, in the event that the Association defaults on any street light account with Progress Energy which is covered by this Agreement, the City shall also, at its sole discretion, have the right to transfer said accounts into the City's name and thereby assume all the rights afforded an account holder.

Section 15. Attorneys Fees. The prevailing party in any litigation arising under this Agreement shall be entitled to recover its reasonable attorneys' and paralegal fees and costs, whether incurred at trial or appeal.

IN WITNESS WHEREOF, the parties have executed this Agreement as of the date first written above.

[Signature Page Follows]

WITNESSES:

Print Name

Print Name

THE ASSOCIATION

By: _____

STATE OF FLORIDA
COUNTY OF _____

The foregoing instrument was acknowledged before me this ____ day of _____, 20____, by _____, who executed the foregoing instrument and acknowledged before me that he executed the same for the uses and purposes therein expressed and who is personally known to me or who has produced _____ as identification and who did not take an oath.

(NOTARY SEAL)

Notary Public Signature

Typed or Printed Notary Name

Print Name

Print Name

**CITY OF WINTER SPRINGS,
a Florida Municipal Corporation:**

By: _____
City Manager

**STATE OF FLORIDA
COUNTY OF SEMINOLE**

The foregoing instrument was acknowledged before me this ____ day of _____,
20____, by _____, City Manager of Winter Springs, Florida, who is personally
known to me.

(NOTARY SEAL)

Notary Public Signature

Typed or Printed Notary Name