



# **CITY COMMISSION**

## REGULAR MEETING

## REVISED AGENDA

**MONDAY, AUGUST 12, 2019 AT 6:30 PM**

CITY HALL - COMMISSION CHAMBERS  
1126 EAST STATE ROAD 434, WINTER SPRINGS, FLORIDA

## **CALL TO ORDER**

Roll Call  
Invocation  
Pledge of Allegiance  
Agenda Changes

## **AWARDS AND PRESENTATIONS**

100. Optimist Club Award Presentation to Police Department Personnel
101. Presentation of Awards Recognizing Specific Camp Sunshine Campers in the Camp Sunshine Camp Program for their Outstanding Character Traits

## **INFORMATIONAL AGENDA**

200. Current Development Projects Update

*Attachments:* Current Projects Map

201. New Recreation Management Software

*Attachments:* None

## **PUBLIC INPUT**

*Anyone who wishes to speak during Public Input on any Agenda Item or subject matter will need to fill out a "Public Input" form. Individuals will limit their comments to three (3) minutes, and representatives of groups or homeowners' associations shall limit their comments to five (5) minutes, unless otherwise determined by the City Commission.*

## **CONSENT AGENDA**

300. Surplus Assets

*Attachments:* Surplus Asset Final List

301. TLBD Landscape Project Supplemental Appropriation

*Attachments:* Landscape Enhancement Proposal - Brightview

*Revisions are noted with \* and with text in italics*



302. FY 2019-2020 Assessment Rolls\*

*\*Note: Text in Italics were previously labeled Exhibit A through K*

*Attachments: Attachment 1 - Resolution 2019-13  
Attachment 2 - Certificate to Non-Ad Valorem Assessment Roll for Oak Forest (OFWBD) - FY 2019-2020  
Attachment 3 - Assessment Summary for Oak Forest (OFWBD) - FY 2019-2020  
Attachment 4 - Oak Forest Assessment Roll (OFWBD) - FY 2019-2020 Annual Assessment; sorted by owner name and parcel identification  
Attachment 5 - Certificate to Non-Ad Valorem Assessment Roll for Tusawilla Assessment Area Phase I - FY 2019-2020  
Attachment 6 - Assessment Summary for Tusawilla Phase I - FY 2019-2020  
Attachment 7 - Tusawilla Phase I Assessment Roll - FY 2019-2020 Annual Assessment; sorted by owner name and parcel identification  
Attachment 8 - Certificate to Non-Ad Valorem Assessment Roll for Tusawilla Phase III Assessment Area - FY 2019-2020  
Attachment 9 - Assessment Summary for Tusawilla Phase III Assessment Area - FY 2019- 2020  
Attachment 10 - Tusawilla Phase III Assessment Area - FY 2019-2020 Annual Assessment; sorted by owner name and parcel identification  
Attachment 11 - DR408A - FY 2019-2020*

303. Asphalt Street Resurfacing Agreement

*Attachments: Exhibit A - Winter Springs Project Agreement  
Exhibit B - Seminole County Agreement and Extension with The Middlesex Corporation  
Exhibit C - The Middlesex Corporation Project Quotation*

304. NRCS Sediment Removal Project Additional Funding Request

*Attachments: Exhibit A - Project Agreement*

305. Resolution 2019-18 - Agreement with Traffic Technology Services, Inc. to Access Traffic Signal Data

*Attachments: Exhibit A - Resolution 2019-18  
Exhibit B - TTS Disclosure Agreement  
Exhibit C - TTS Data Dashboard Examples*

306. Parks and Recreation Fees

*Attachments: Resolution 2019-20  
Exhibit A  
Proposed Fee Revision Chart*

307. Trotwood Park Fitness Zone\*

*Attachments: Pro Playground Quote*

308. Acceptance of Donation for Police K9 Purchase #1

*Attachments:* Letter from Donor, Mr. Edward Lund

309. Acceptance of Donation for Police K9 Purchase #2

*Attachments:* None

310. Minutes from the Monday, July 8, 2019 City Commission Regular Meeting

*Attachments:* Minutes

## **PUBLIC HEARINGS AGENDA**

400. Public Adoption Hearing and Second Reading of Ordinance 2019-06 regarding EAR based amendments to the Comprehensive Plan related to the Intergovernmental Coordination Element and transmit to the Department of Economic Opportunity and other reviewing agencies

*Attachments:* Ordinance 2019-06  
Legal Advertisement  
Exhibit A  
DEO Review (ORC)

## **REGULAR AGENDA**

500. City Manager Position

*Attachments:* Experienced Candidate List  
Resumes

## **REPORTS**

600. City Attorney Anthony A. Garganese, Esquire

601. Interim City Manager Shawn Boyle

602. City Clerk Andrea Lorenzo-Luaces, MMC

603. Seat Five Commissioner Geoff Kendrick

604. Mayor Charles Lacey

605. Seat One Commissioner Jean Hovey

606. Seat Two Commissioner/Deputy Mayor Kevin Cannon

607. Seat Three Commissioner Ted Johnson

608. Seat Four Commissioner TiAnna Hale

## **PUBLIC INPUT**

*Anyone who wishes to speak during Public Input on any Agenda Item or subject matter will need to fill out a "Public Input" form. Individuals will limit their comments to three (3) minutes, and representatives of groups or homeowners' associations shall limit their comments to five (5) minutes, unless otherwise determined by the City Commission.*

## **ADJOURNMENT**

## **PUBLIC NOTICE**

This is a Public Meeting, and the public is invited to attend and this Agenda is subject to change. Please be advised that one (1) or more Members of any of the City's Advisory Boards and Committees may be in attendance at this Meeting, and may participate in discussions.

Persons with disabilities needing assistance to participate in any of these proceedings should contact the City of Winter Springs at (407) 327-1800 "at least 48 hours prior to meeting, a written request by a physically handicapped person to attend the meeting, directed to the chairperson or director of such board, commission, agency, or authority" - per Section 286.26 *Florida Statutes*.

"If a person decides to appeal any decision made by the board, agency, or commission with respect to any matter considered at such meeting or hearing, he or she will need a record of the proceedings, and that, for such purpose, he or she may need to ensure that a verbatim record of the proceedings is made, which record includes the testimony and evidence upon which the appeal is to be based" - per Section 286.0105 *Florida Statutes*.



# INFORMATIONAL AGENDA ITEM 200

CITY COMMISSION REVISED AGENDA  
 AUGUST 12, 2019 | REGULAR MEETING

## TITLE

Current Development Projects Update

## SUMMARY

PROPOSED DEVELOPMENT PROJECTS			
PROJECT NAME	LOCATION	LAST ACTION ITEM	CURRENT STATUS
AITC Office Building	863 N US 17-92	N/A	Final Engineering & Aesthetic Plans are under Staff review.
Winter Springs Medical Office	E SR 434 – West of Hacienda Dr.	N/A	Final Engineering Plans are under Staff review. Aesthetic Plans are being prepared.
Beazer Homes Senior (55+) Condominium Project (The Gatherings at Winter Springs- 108 Units)	Town Center - West side of Tuskawilla, north of Blumberg	Special Exceptions approved by City Commission on 8/13/18.	Engineering & Aesthetic Plans to be prepared by the developer.
Iriye Suites Live-Work Community	Town Center	Special Exceptions & Development Agreement approved by City Commission on 1/28/19.	Final Engineering & Aesthetic Plans are being prepared by the developer.
Wendy's	Town Center	N/A	Preliminary Site Plan and Aesthetic Plans are under staff review.
Dream Finders Townhomes (Winter Springs Townhomes) - 114 Units	Town Center - East side of Michael Blake Blvd.	Preliminary Engineering approved by City Commission on 1/8/18.	Final Engineering & Aesthetic Plans are under Staff review.
The Studios at Tuscawilla	Vistawilla Drive	N/A	Final Engineering Plans are under Staff review. A Community Workshop was held on 7/19/19.

<b>APPROVED DEVELOPMENT PROJECTS / UNDER CONSTRUCTION</b>			
<b>PROJECT NAME</b>	<b>LOCATION</b>	<b>LAST ACTION ITEM</b>	<b>CURRENT STATUS</b>
Winter Springs Town Center Retail Building (Ocean Bleu)	Town Center	Final Engineering & Aesthetic Plans approved by City Commission on 6/10/19.	Developer to schedule preconstruction meeting prior to starting work.
Tuskawilla Crossings: 379 single-family homes	Town Center	Final Engineering, Development Agreement & Aesthetics approved by City Commission on 4/24/17. Plat approved 8/13/18. Phase 1 and Phase 2 Site work approved by City Commission.	Site work complete. Homes under construction.
The Blake Apartments (Catalyst Apartments): 279 apartment units	Town Center	Plat approved 10/23/17. Development Agreement & Final Engineering were approved by City Commission on 1/9/17.	Buildings under construction.
Hawthorn ILF (Winter Springs Retirement Residence): 144 independent living suites	Town Center	Final Engineering, Aesthetic Review, & Development Agreement approved by City Commission on 1/22/18.	Site work under construction.
Northern Oaks: 35 single-family homes by Dream Finders Homes	North side of SR 434, East of SR 417	Final Engineering & Waivers approved by City Commission on 3/13/17. Preconstruction meeting held 10/17/17. Aesthetic Review approved by City Commission on 4/9/18. Plat is recorded.	Site work under construction. Building permits issued.
Southern Oaks: 54 single-family homes	West of DeLeon St. & North of SR 434	Final Engineering, Aesthetic Review, & Development Agreement approved on 6/22/15. Plat is recorded. City Commission accepted site work on 8/14/17.	Site work complete. Homes under construction.

## **RECOMMENDATION**

Staff recommends the City Commission receive and review the information provided.





# Winter Springs Economic Development

## Current Projects

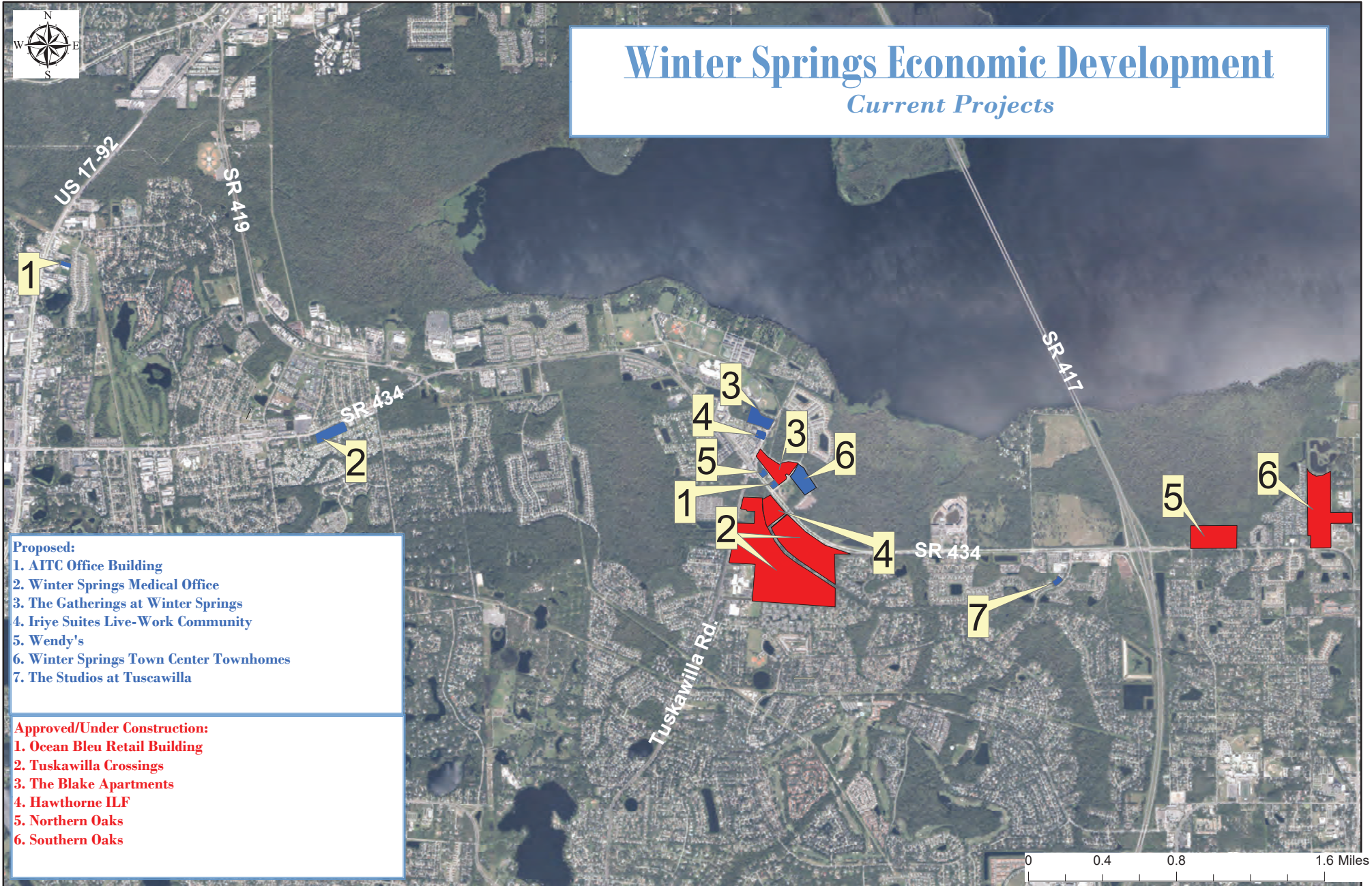

### Proposed:

1. AITC Office Building
2. Winter Springs Medical Office
3. The Gatherings at Winter Springs
4. Iriye Suites Live-Work Community
5. Wendy's
6. Winter Springs Town Center Townhomes
7. The Studios at Tuskawilla

### Approved/Under Construction:

1. Ocean Bleu Retail Building
2. Tuskawilla Crossings
3. The Blake Apartments
4. Hawthorne ILF
5. Northern Oaks
6. Southern Oaks



# INFORMATIONAL AGENDA ITEM 201

CITY COMMISSION REVISED AGENDA  
AUGUST 12, 2019 | REGULAR MEETING

## TITLE

New Recreation Management Software

## SUMMARY

Staff is informing the City Commission that Parks and Recreation will be moving from ActiveNet recreation software to CivicRec. CivicRec is a recreation management software that offers many features such as:

- Online registration and rentals
- Electronic record-keeping
- Map view of parks
- Rental availability calendar
- Integration with our current website
- Residency verification

The cost of the new system is approximately \$10,500, which includes all training, hardware, and software. The software is anticipated to be live on October 1, 2019.

## RECOMMENDATION

Staff recommends the City Commission receive and review the information provided.

Surplus Assets Final List to Commission

Provided by City of Winter Springs

Comission Date	Methods of Disposal
8/12/2019	1 - Auction 6 - Totaled/Accident 2 - eWaste 7 - Lost 3 - Destroy 8 - Stolen 4 - Salvage 9 - Donated 5 - Trade-in 10 - Transfer

Surplus Assets

Departments	Description	Asset #	Serial #	Original Cost	Model #	Method of Disposal
PD	Patriot Shields		Expired			3
PD	Ballistic Shields		Expired			3
PD	Bullard Thermal Imager					1
PD	Garmin Rino 120		166042970			1
PD	Garmin Rino 120		166060145			1
PD	Garmin Rino 120		166043306			1
PD	Garmin Rino 120		166060697			1
PD	Garmin Rino 120		166043311			1
PD	13 Motorcycle/ATV Helmet		Expired			3
Parks	John Deer Mower 2653-A	300596	Purchased 2006	\$ 22,820		4
Parks	Hustler 7700 Fairway Mower	303318	Purchased 2011	\$ 29,000		4
Parks	John Deer 2653-B Mower	300804	Purchased 2007	\$ 23,350		4
Parks	Lely Hopper/Spreader	303455	Purchased 2013	\$ 3,495		4





# CONSENT AGENDA ITEM 301

CITY COMMISSION REVISED AGENDA  
AUGUST 12, 2019 | REGULAR MEETING

## TITLE

TLBD Landscape Project Supplemental Appropriation

## SUMMARY

A capital project has been identified for the TLBD Capital/DS Fund (#261), and FY19 funding is requested. Presently, this fund is budgeted to have reserves of \$111,308 on September 30, 2019. The TLBD Advisory Board met on July 24, 2019, and a consensus was reached to move ahead with a full-scale landscape replacement at the North and South fountain entrances. This project is an eligible capital project for fund #261. A supplemental appropriation of \$36,000 is requested to cover the preferred proposal of \$33,402.66 (dwarf bottlebrush option) with a modest contingency.

## RECOMMENDATION

Staff recommends the City Commission authorize approval of a \$36,000 supplemental appropriation from fund #261 for a capital landscape project



Tuscawilla Lighting & Beautifying  
Winter Springs, FL

Landscape Enhancement Proposal



July 19, 2019

City of Winter Springs  
1126 East State Road 434  
Winter Springs, FL 32708

### **Landscape Enhancement Proposal for Tuscawilla South Fountain**

Dear Kevin Maddox,

Thank you for the opportunity to present you with a landscape enhancement proposal for your property. We hereby propose to furnish in the utmost professional manner, all necessary labor and materials to perform the following work, as per BrightView Landscape Maintenance scope of work & specifications noted in the following pages. BrightView Landscape Maintenance's main objective is to exceed our customer's expectations and greatly enhance the aesthetic appeal of your property.

#### **This Landscape Enhancement Proposal Includes Services For the Following:**

- Landscape demolition of materials not to remain for the proposed design
- Installation of materials noted in the following pages (i.e. plants, mulch, sod etc.)
- Irrigation
- Fees associated with mobilization, delivery & disposal of materials.
- A post planting fertilizer application for all new plantings.





Work Area Map



## Proposal for Extra Work at Tuscawilla Lighting and Beauti

Property Name	Tuscawilla Lighting and Beauti	Contact	Kevin Maddox
Property Address	District Maintenance Winter Springs & Tuskawilla Road Winter Springs , FL 32708	To	Winter Springs City of
		Billing Address	Urban Beautification Manager 1126 East State Rd 434 Winter Springs , FL 32708

Project Name Tuskawilla Road Fountain (Tuskawilla Road) (Roebelenii at Top Tier Option)

Project Description Remove Existing Landscape, Add New Plants & Materials

### Scope of Work

If Client Decides to Go with Dwarf Bottlebrush VS. Either Agapanthus or Duranta, Then Price would go up @ = \$33, 402.66

QTY	UoM/Size	Material/Description
<b>North Side / Plants &amp; Misc. Materials</b>		
100.00	EACH	Seasonal Annuals - 4" (Addition to Existing)
1.00	EACH	Bromeliad - Aechmea blanchetiana Deep Orange/Yellow - 10"
2.00	EACH	Bromeliad - Imperialis 'Malbec' - 9"
46.00	EACH	Liriope 'Emerald Goddess' - 1 Gal.
10.00	EACH	Society Garlic - 1 Gal.
99.00	EACH	Dwarf Podocarpus 'Pringles' - 3 Gal.
60.00	EACH	Agapanthus africanus or Duranta 'Gold Mound' - 3 Gal.
21.00	EACH	Variegated Arboicola - 3 Gal.
30.00	EACH	Croton 'Magnificent' - 3 Gal.
23.00	EACH	Plumbago 'Imperial Blue' - 3 Gal.
34.00	EACH	Hawaiian Ti 'Auntie Lou' - 3 Gal.
72.00	EACH	Dwarf Bougainvillea 'Helen Johnson' - 3 Gal.
1,200.00	SQUARE FEET	St. Augustine Sod - Installed
3.50	TON	River Jacks 3-5" - Bulk Installed
1.50	TON	Florida Fieldstone Boulder-(3 Boulders @ 2x2x2)
6.00	EACH	Phoenix roebelenii "DOUBLE" - 6' B&B
<b>South Side / Plant &amp; Misc. Materials</b>		
100.00	EACH	Seasonal Annuals - 4" (Addition to Existing)
68.00	EACH	Liriope 'Emerald Goddess' - 1 Gal.
30.00	EACH	Society Garlic - 1 Gal.
72.00	EACH	Dwarf Bougainvillea 'Helen Johnson' - 3 Gal.
25.00	EACH	Croton 'Magnificent' - 3 Gal.

**THIS IS NOT AN INVOICE**

This proposal is valid for 60 days unless otherwise approved by BrightView Landscape Services, Inc.  
4777 Old Winter Garden Road, Orlando, FL 32811 ph. (407) 292-9600 fax (407) 291-4966

## Proposal for Extra Work at Tusawilla Lighting and Beauti

108.00	EACH	Dwarf Podocarpus 'Pringles' - 3 Gal.
25.00	EACH	Hawaiian Ti 'Auntie Lou' - 3 Gal.
60.00	EACH	Agapanthus africanus or Duranta 'Gold Mound' - 3 Gal.
800.00	SQUARE FEET	St. Augustine Sod - Installed
5.00	EACH	Phoenix roebelenii "DOUBLE" - 6' B&B

**Labor & Misc.**

80.00	HOURLY	Enhancement Crew / Demo / Stump Removal of Hollies & Japanese Blueberries after Flush Cut
1.00	LOAD	30/40 CUBIC YARD GREEN WASTE ONLY - Roll-Off/Dumpster
30.00	CUBIC YARD	Mulch Installed - Mini Pine Bark (For Newly Planted & Disturbed Areas Only)
2.00	CUBIC YARD	Seasonal Annual Soil

**Irrigation**

1.00	LUMP SUM	Irrigation Retrofit
------	----------	---------------------

**Tree Removals / Grading Beds North and South Fountains**

45.00	HOURLY	Remove and grade excess of dirt on beds and haul it away
1.00	LUMP SUM	Flush Cut of (3) Holly & (2) Japanese blueberry on South Fountain. Flush Cut of (3) Holly & (3) Japanese blueberry on North Fountain. Includes debris haul off.

**\*\*Mulch Quantity Listed is for New planted or Disturbed areas ONLY\*\***

**\*\*Seasonal Annuals on this proposal are an ADDITION To the Existing Seasonal Annuals on Contract\*\***

**\*\*\*\*The irrigation Retro-Fit pricing stated in the proposal was based upon the existing system having sufficient pressure & volume to accommodate the new plantings. Any mainline, lateral supply lines, new valves, wire and or Controllers which may be necessary to provide sufficient coverage would be an extra price\*\*\*\***

For internal use only

**SO#** 6986834  
**JOB#** 460400196  
**Service Line** 130

**Total Price** \$32,188.38

**THIS IS NOT AN INVOICE**

This proposal is valid for 60 days unless otherwise approved by BrightView Landscape Services, Inc.  
4777 Old Winter Garden Road, Orlando, FL 32811 ph. (407) 292-9600 fax (407) 291-4966



## TERMS & CONDITIONS

1. The Contractor shall recognize and perform in accordance with written terms, written specifications and drawings only, contained or referred to herein. All materials shall conform to bid specifications.
2. **Work Force:** Contractor shall designate a qualified representative with experience in landscape maintenance/construction upgrades or when applicable in tree management. The workforce shall be competent and qualified, and shall be legally authorized to work in the U.S.
3. **License and Permits:** Contractor shall maintain a Landscape Contractor's license, if required by State or local law, and will comply with all other license and permit requirements of the City, State and Federal Governments, as well as all other requirements of law.
4. **Taxes:** Contractor agrees to pay all applicable taxes, including sales tax where applicable on material supplied.
5. **Insurance:** Contractor agrees to provide General Liability Insurance, Automotive Liability Insurance, Worker's Compensation Insurance, and any other insurance required by law or Client/Owner, as specified in writing prior to commencement of work. If not specified, Contractor will furnish insurance with \$1,000,000 limit of liability.
6. **Liability:** Contractor shall indemnify the Client/Owner and its agents and employees from and against any third party liabilities that arise out of Contractor's work to the extent such liabilities are adjudicated to have been caused by Contractor's negligence or willful misconduct. Contractor shall not be liable for any damage that occurs from Acts of God are defined as those caused by windstorm, hail, fire, flood, earthquake, hurricane and freezing, etc. Under these circumstances, Contractor shall have the right to renegotiate the terms and prices of this agreement within sixty (60) days. Any illegal trespass, claims and/or damages resulting from work requested that is not on property owned by Client/Owner or not under Client/Owner management and control shall be the sole responsibility of the Client/Owner.
7. **Subcontractors:** Contractor reserves the right to hire qualified subcontractors to perform specialized functions or work requiring specialized equipment.
8. **Additional Services:** Any additional work not shown in the above specifications involving extra costs will be executed only upon signed written orders, and will become an extra charge over and above the estimate.
9. **Access to Jobsite:** Client/Owner shall provide all utilities to perform the work. Client/Owner shall furnish access to all parts of jobsite where Contractor is to perform work as required by the Contract or other functions related thereto, during normal business hours and other reasonable periods of time. Contractor will perform the work as reasonably practical after the owner makes the site available for performance of the work.
10. **Invoicing:** Client/Owner shall make payment to Contractor within fifteen (15) days upon receipt of invoice. In the event the schedule for the completion of the work shall require more than thirty (30) days, a progress bill will be presented by month end and shall be paid within fifteen (15) days upon receipt of invoice.
11. **Termination:** This Work Order may be terminated by the either party with or without cause, upon seven (7) work days advance written notice. Client/Owner will be required to pay for all materials purchased and work completed to the date of termination and reasonable charges incurred in demobilizing.
12. **Assignment:** The Owner/Client and the Contractor respectively, bind themselves, their partners, successors, assignees and legal representative to the other party with respect to all covenants of this Agreement. Neither the Owner/Client nor the Contractor shall assign or transfer any interest in this Agreement without the written consent of the other provided, however, that consent shall not be required to assign this Agreement to any company which controls, is controlled by, or is under common control with Contractor or in connection with assignment to an affiliate or pursuant to a merger, sale of all or substantially all of its assets or equity securities, consolidation, change of control or corporate reorganization.
13. **Disclaimer:** This proposal was estimated and priced based upon a site visit and visual inspection from ground level using ordinary means, at or about the time this proposal was prepared. The price quoted in this proposal for the work described, is the result of that ground level visual inspection and therefore our company will not be liable for any additional costs or damages for additional work not described herein, or liable for any incidents/accidents resulting from conditions, that were not ascertainable by said ground level visual inspection by ordinary means at the time said inspection was performed. Contractor cannot be held responsible for unknown or otherwise hidden defects. Any corrective work proposed herein cannot guarantee exact results. Professional engineering, architectural, and/or landscape design services ("Design Services") are not included in this Agreement and shall not be provided by the Contractor. Any design defects in the Contract Documents are the sole responsibility of the Owner. If the Client/Owner must engage a licensed engineer, architect and/or landscape design professional, any costs concerning these Design Services are to be paid by the Client/Owner directly to the designer involved.

14. **Cancellation:** Notice of Cancellation of work must be received in writing before the crew is dispatched to their location or Client/Owner will be liable for a minimum travel charge of \$150.00 and billed to Client/Owner.

The following sections shall apply where Contractor provides Customer with tree care services:

15. **Tree & Stump Removal:** Trees removed will be cut as close to the ground as possible based on conditions to or next to the bottom of the tree trunk. Additional charges will be levied for unseen hazards such as, but not limited to concrete brick filled trunks, metal rods, etc. If requested mechanical grinding of visible tree stump will be done to a defined width and depth below ground level at an additional charge to the Client/Owner. Defined backfill and landscape material may be specified. Client/Owner shall be responsible for contacting Underground Service Alert to locate underground utility lines prior to start of work. Contractor is not responsible damage done to underground utilities such as but not limited to, cables, wires, pipes, and irrigation parts. Contractor will repair damaged irrigation lines at the Client/Owner's expense.
16. **Waiver of Liability:** Requests for crown thinning in excess of twenty-five percent (25%) or work not in accordance with ISA (international Society of Arboricultural) standards will require a signed waiver of liability.

### Acceptance of this Contract

Contractor is authorized to perform the work stated on the face of this Contract. Payment will be 100% due at time of billing. If payment has not been received by BrightView within fifteen (15) days after billing, BrightView shall be entitled to all costs of collection, including reasonable attorneys' fees and it shall be relieved of any obligation to continue performance under this or any other Contract with Client/Owner. Interest at a per annum rate of 1.5% per month (18% per year), or the highest rate permitted by law, may be charged on unpaid balance 30 days after billing.

NOTICE: FAILURE TO MAKE PAYMENT WHEN DUE FOR COMPLETED WORK ON CONSTRUCTION JOBS, MAY RESULT IN A MECHANIC'S LIEN ON THE TITLE TO YOUR PROPERTY

### Customer

Landscape Manager

Signature: \_\_\_\_\_ Title: \_\_\_\_\_

Kevin Maddox July 19, 2019

Printed Name: \_\_\_\_\_ Date: \_\_\_\_\_

BrightView Landscape Services, Inc. "BrightView"

Associate Account Manager

Signature: \_\_\_\_\_ Title: \_\_\_\_\_

Omar Lopez July 19, 2019

Printed Name: \_\_\_\_\_ Date: \_\_\_\_\_

Job #: 460400196 Proposed Price: \$32,188.38  
SO # 6986834

# Exclusions And Qualifications

## Personnel/ Working Hours

- This Proposal is based upon personnel working normal daytime hours, 8 hour work day, 40 hour work week. Proposal excludes working in an ineffective manner (rain, unsafe working conditions, etc.)
- BrightView is an open shop contractor, non-signatory to any labor agreements.
- This Proposal is based on non-prevailing wage and non-union labor rates.
- This proposal is based on performing the work in one continuous operation and includes one mobilization of equipment, tools and resources to and from site.

## Utilities, Traffic Control, and Permitting

- BrightView excludes any permits or applicable fees in this proposal. Permits and fees, if required, are to be supplied and paid for by others including street closure and traffic control plans.
- Permanent or temporary Water meter fees, permits, installation and cost for water not included in proposal.
- BrightView Landscape Maintenance, Inc. is not responsible for underground or overhead utilities or their re-routing.
- BrightView is not responsible for unmarked private utilities.
- A minimum of (48) hour notice prior to mobilization must be provided for proper underground utility marking, etc. in public areas.
- The owner shall be responsible for identifying and marking all underground utilities within in the work site.
- BrightView shall accept no responsibility for damage to any unmarked underground utilities.

## Scope of Work/ Project Specifications

- No import or export soils are provided for in this proposal except as noted in the scope of work. All planting spoils to be used on-site.
- Equipment access roads and level crane pads are to be provided at the time of installation and approved by BrightView prior to mobilization.
- Any and all concrete or asphalt cutting, demolition, removal and replacement to be performed by others.
- Hardscape, electrical, surveying, metal work or waterproofing or any other scope not specified in this proposal are excluded.
- No demolition work is provided for in this proposal except as noted in the scope of work.
- BrightView will receive the site clean and free of weeds and construction debris and in finish graded condition (plus or minus 1/10th foot)
- Site is to be readily accessible by smooth bucket skip loader, forklift, and workmen with hand tools, semi-truck and trailer.
- Cutting, patching or penetration of planter walls is excluded. Coring of structures has not been included. All necessary penetrations into existing planters, sealing of these penetrations, etc. to be by others.
- Waterproofing, protection boards, and topping slabs shall be completed, in place and tested by others prior to mobilization.
- Specified plant materials are subject to availability at the time of construction.
- Design Concepts provided represent plant material at a 1-2 year growth maturity and NOT at time of install.

## Irrigation

- BrightView shall be given sufficient notice to place irrigation sleeves prior to paving, curbing or wall footings being poured.
- No hardscape (asphalt, concrete, etc.) cutting for purposes of installing irrigation piping, wires, etc. is provided in this proposal.
- Irrigation to be taken from provided point of connection. Water meter installation excluded.
- Irrigation to be installed per plan. Any necessary irrigation modifications to be billed at time and materials.
- Power (110v) P.O.C. for irrigation controller will be provided by the others.
- BrightView will warranty the irrigation system, with regards to material and workmanship for (90) days post-installation.
- The irrigation Retro-Fit pricing stated in the proposal was based upon the existing system having sufficient pressure & volume to accommodate the new plantings. Any mainline, lateral supply lines, new valves, wire and or Controllers which may be necessary to provide sufficient coverage would be an extra price

## Warranty

- BrightView shall Warranty all shrubs, ground cover and vines for a period of (90) days. Specimen trees for a period of one (1) year. Warranty will extend for as long as BrightView is retained as the maintenance provider.
- Warranty does not extend beyond the natural life cycle of the plant material. (E.G. annual color, perennials, biennials, etc.)





Remove Large Japanese Blueberries & Add Phoenix roebelenii "Double"

Hawaiian Ti 'Auntie Lou'

Dwarf Bougainvillea 'Helen Johnson'

Croton 'Magnificent'

Liriope 'Emerald Goddess'

Plumbago 'Imperial blue'

3-5" River Jack, Add 3 Boulders & Aechmea blanchetiana / Imperialis (Bromeliads)

Add Variegated Arbuticola to make tear drop bed

Continue Dwarf Podocarpus Hedge

Eliminate Jasmine Beds / Sod



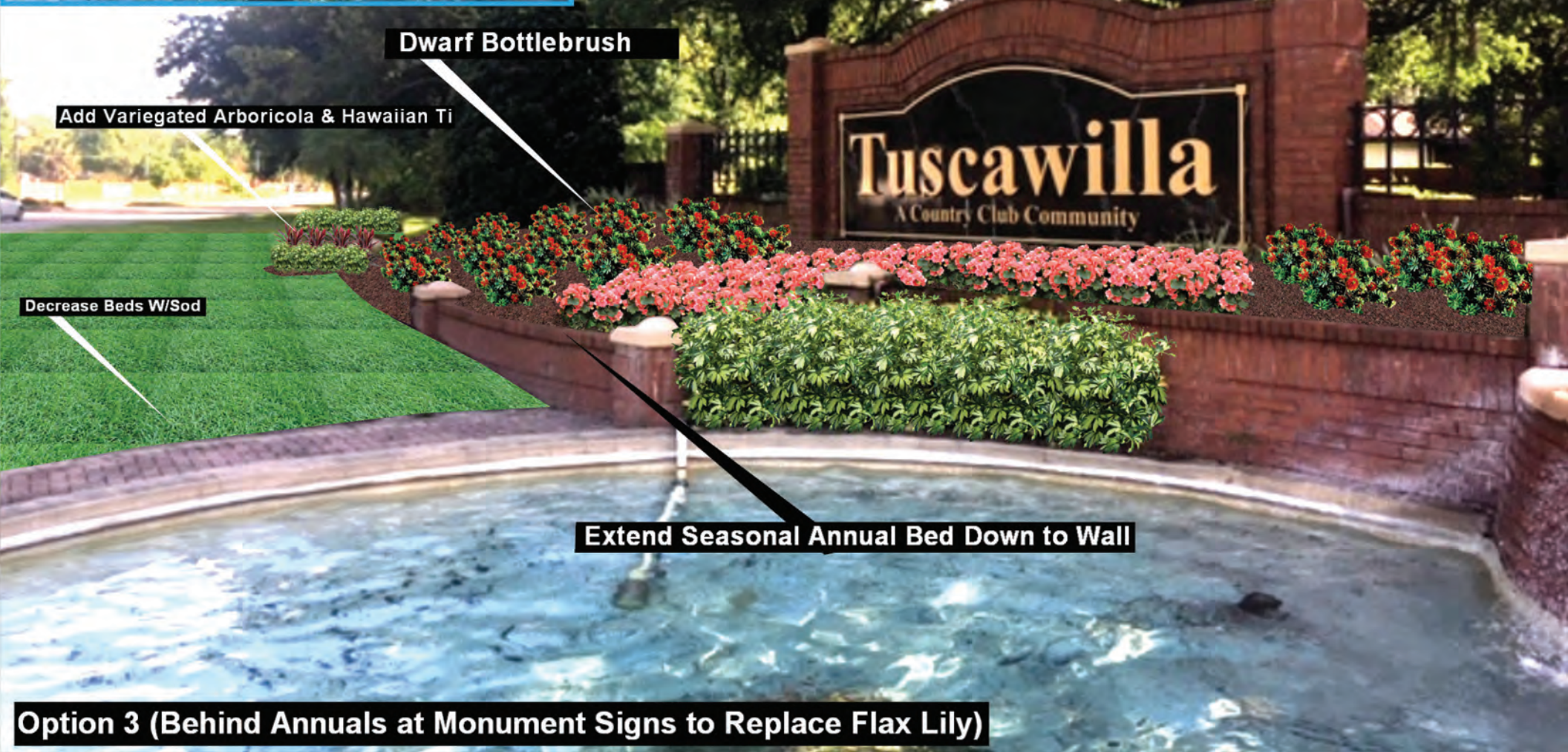





# CONSENT AGENDA ITEM 302

CITY COMMISSION REVISED AGENDA  
AUGUST 12, 2019 | REGULAR MEETING

## TITLE

FY 2019-2020 Assessment Rolls

*Revisions are noted with \* and with text in italics*

## SUMMARY

Final assessment rolls and documents must be authorized and submitted to the Seminole County Tax Collector for Tax Year 2019 (Fiscal Year 2020) relating to the Oak Forest Wall and Beautification District, the Tuscawilla Lighting and Beautification Assessment Area Phase I also known as Tuscawilla Lighting and Beautification District (TLBD) and Tuscawilla Phase III Assessment Area (also known as Hawk's Reserve and Tuscawilla Units 12/12A Wall) by September 15, 2019. The adoption of the annual resolution is required under the City's Ordinance No. 98-704. A rate schedule for each assessment follows, with last year's assessment and the proposed assessments for the 2019 tax year:

*\*This table was inadvertently left out of a previous version of the agenda item*

	TAX YEAR			Incr (Decr)
	Legal Max	2018 Assessment	2019 Proposal	
<b>Tuscawilla Lighting and Beautification District (per ERU):</b>				
TLBD Maintenance (Phases I & II)	\$128	\$120	\$120	\$0
TLBD Phase I Capital/Debt Service	\$43	\$36	\$36	\$0
	<b>\$171</b>	<b>\$156</b>	<b>\$156</b>	<b>\$0</b>
<b>Oak Forest (per BU):</b>				
Oak Forest Maintenance	<b>\$63</b>	<b>\$60</b>	<b>\$60</b>	<b>\$0</b>
<b>Tuscawilla III (per BU):</b>				
Tuscawilla III Maintenance	\$87	\$75	\$87	\$12
Tuscawilla III Capital/Debt Service	\$88	\$85	\$85	\$0
	<b>\$175</b>	<b>\$160</b>	<b>\$172</b>	<b>\$12</b>

### **Tuscowilla Lighting and Beautification Assessment Area - Phases I and II**

- On November 14, 2005, the City Commission adopted Resolution 2005-43 thereby creating and imposing special assessments within the Tuscowilla (Phase II) Assessment Area. The maintenance assessments for Phase I and II were later combined into one maintenance assessment, while the two capital assessments were distinct. Now the only two assessments within the Tuscowilla Lighting and Beautification Assessment Area are Phase I Capital and Maintenance (Phase I and II combined).
- On May 29, 2007 a public hearing was held, wherein the City Commission adopted Resolution Number 2007-24, (amending Resolution Nos. 99-885, 99-887, 99-888, 2005-40 and 2005-43) approving assessment rates of \$43.00 per ERU for Phase I capital, \$17.00 per ERU for Phase II capital and \$126.00 per ERU for maintenance (Phases I and II combined) as related to the Tuscowilla Lighting and Beautification Assessment Area - Phases I and II. The legal maximums were established at \$128/ERU for maintenance and \$43/ERU and \$17/ERU, respectively for Phase I and II capital/debt service. Phase II capital is now paid off.
- In late 2012, as part of a comprehensive review by our new assessment consultant, NBS, 111 additional parcels not previously included in the TLBD Assessment Area were identified as receiving a special benefit from the Tuscowilla Improvement Area. A majority of these parcels are part of the newly-platted Greens at Tuscowilla Subdivision, the next group is within the Fox Glen Subdivision and the remaining parcels are located in various subdivisions throughout Tuscowilla.
- Tax Year 2016 was the final assessment for the Tuscowilla Phase II Capital/Debt Service assessment.
- Residents are permitted to make capital assessment prepayments until July 15th of each tax year. Since the last tax roll certification there have been no capital assessment prepayments for TLBD Phase I Capital/Debt Service.

### **Oak Forest Wall and Beautification District (OFWBD)**

- On May 10, 2000, the City Commission created and imposed special assessments within the Oak Forest Assessment Area also known as the Oak Forest Wall and Beautification District.
- On May 29, 2007, the City Commission approved Resolution Number 2007-23, establishing assessment rates of \$57/BU for maintenance and \$72/BU for capital as related to the OFWBD. The legal maximums were established at \$63/BU for maintenance and \$72/BU for capital/debt service.
- Tax Year 2016 was the final assessment for the Oak Forest Capital/Debt Service assessment.

### **Tuscawilla Phase III Assessment Area (Maintenance and Capital Improvement/Debt Service)**

- On August 12, 2013, the City Commission approved Resolution 2013-22, creating the Tuscawilla Phase III Assessment Area. The capital assessment rate as originally established remains unchanged at \$85/BU for capital/debt service (\$88/BU legal maximum). It is proposed that the maintenance assessment rate be increased from \$85/BU to the legal maximum of \$87/BU.
- Residents are permitted to make capital assessment prepayments until July 15th of each tax year. Since the last tax roll certification there have been no capital assessment prepayments for Tuscawilla III Capital/Debt Service.

### **All Assessment Areas/Districts**

- The Certificate to Non-Ad Valorem Assessment Roll, Assessment Summary and FY 2019-2020 (Tax Year 2019) Annual Assessment Rolls are attached for each of the above-described assessment areas.
- The assessment rolls for the Oak Forest Wall and Beautification District, the Tuscawilla Lighting and Beautification District and Tuscawilla Phase III Assessment Area are available for public inspection in the City Hall lobby, the City Clerk's office, and the Finance and Administrative Services Department.

**\* NOTE: THE TEXT AND LINK BELOW DID NOT APPEAR IN THE ORIGINAL AGENDA ITEM SUMMARY.**

*Please note: the attachment for this agenda item is the condensed version due to file size. Please see here, <https://bit.ly/2YNhDtk>, for the complete attachment.*

### **RECOMMENDATION**

Staff recommends the City Commission adopt Resolution 2019-13 authorizing the submission of the Certificates to Non-Ad Valorem Assessment Roll, Assessment Summary and FY 2019-2020 Annual Assessment Roll for Tax Year 2019 relating to the Oak Forest Wall and Beautification District (Maintenance only), the Tuscawilla Lighting and Beautification Assessment Area - Maintenance and Phase I Capital) and Tuscawilla Phase III Assessment Area (Maintenance and Capital) to the Seminole County Tax Collector by September 15, 2019.

**CITY OF WINTER SPRINGS, FLORIDA**

**RESOLUTION NUMBER 2019-13**

A RESOLUTION OF THE CITY COMMISSION OF THE CITY OF WINTER SPRINGS, FLORIDA, APPROVING ASSESSMENT ROLLS FOR VARIOUS ASSESSMENT AREAS ESTABLISHED PURSUANT TO ORDINANCE NO. 98-704; ESTABLISHING THE LIEN ASSOCIATED THEREWITH; DIRECTING THAT THE ASSESSMENT ROLLS BE CERTIFIED TO THE SEMINOLE COUNTY TAX COLLECTOR; PROVIDING FOR THE REPEAL OF PRIOR INCONSISTENT RESOLUTIONS; PROVIDING FOR SEVERABILITY; AND PROVIDING AN EFFECTIVE DATE.

**WHEREAS**, the City Commission (the "Commission") of the City of Winter Springs, Florida, enacted Ordinance No. 98-704 on July 27, 1998 (the "Ordinance"), to provide for the creation of assessment areas and authorize the imposition of special assessments to fund the construction and maintenance of local improvements to serve the property located therein; and

**WHEREAS**, pursuant to the Ordinance, the Commission created and imposed special assessments within the Tuscawilla Improvement Area on August 9, 1999, the Tuscawilla Service Area on August 9, 1999, the Oak Forest Assessment Area on May 10, 2000, the Tuscawilla (Phase II) Assessment Area on November 14, 2005 and the Tuscawilla (Phase III) Assessment Area on August 12, 2013; and

**WHEREAS**, pursuant to the provisions of the Ordinance, the Commission is required to adopt an "Annual Assessment Resolution" during its budget process for each fiscal year to approve the assessment roll for such fiscal year; and

**WHEREAS**, the Commission deems that this Resolution is in the best interests of the public health, safety and welfare of the citizens of the City of Winter Springs, Florida.

**NOW, THEREFORE, BE IT RESOLVED BY THE CITY COMMISSION OF THE CITY OF WINTER SPRINGS, FLORIDA, AS FOLLOWS:**

**SECTION 1. RECITALS.** The above recitals are deemed true and correct and are hereby made a specific part of this resolution.

**SECTION 2. AUTHORITY.** This Resolution is adopted pursuant to the Ordinance, Chapter 166, Florida Statutes, and other applicable provisions of law.

**SECTION 3. DEFINITIONS.** All capitalized terms in this Resolution shall have the meanings defined in the Ordinance and the implementing resolutions adopted pursuant thereto.

**SECTION 4. APPROVAL OF ASSESSMENT ROLLS.** Pursuant to Section 197.3632, Florida Statutes, each of the following assessment rolls shall be certified to the Seminole County Tax Collector prior to September 15, 2019, along with any necessary changes subsequent to the date hereof permitted under Sections 3.12 and 4.12 of the Ordinance and the Uniform Assessment Collection Act.

- A. Tusawilla Improvement Area. The non-ad valorem assessment roll on file with the City Clerk for the Tusawilla Improvement Area is hereby approved, such roll setting the annual rate of \$36.00 per Equivalent Residential Unit (reflecting no change compared to the prior year amount and \$7.00 less than the maximum rate of \$43.00 previously authorized by the City).
- B. Tusawilla Maintenance Assessment Area. The non-ad valorem assessment roll on file with the City Clerk for the Tusawilla Maintenance Assessment Area is hereby approved, such roll setting the annual rate of \$120.00 per Equivalent Residential Unit (reflecting no change compared to the prior year amount and \$8.00 less than the maximum rate of \$128.00 previously authorized by the City).
- C. Oak Forest Assessment Area (Maintenance). The non-ad valorem assessment roll on file with the City Clerk for the Oak Forest Assessment Area (Maintenance) is hereby approved, such roll setting the annual rate of \$60.00 per Benefit Unit (reflecting no change from the prior year amount and \$3.00 less than the maximum rate of \$63.00 previously authorized by the City).
- D. Tusawilla (Phase III) Assessment Area (Capital). The non-ad valorem assessment roll on file with the City Clerk for the Tusawilla (Phase III) Assessment Area (Capital) is hereby approved, such roll setting the annual rate of \$85.00 per Benefit Unit (reflecting no change compared to the prior year amount and \$3.00 less than the maximum rate of \$88.00 previously authorized by the City).
- E. Tusawilla (Phase III) Assessment Area (Maintenance). The non-ad valorem assessment roll on file with the City Clerk for the Tusawilla (Phase III)

Assessment Area (Maintenance) is hereby approved, such roll setting the annual rate of \$87.00 per Benefit Unit (reflecting an increase of \$12.00 compared to the prior year amount and equal to the maximum rate of \$87.00 previously authorized by the City).

**SECTION 5. ASSESSMENT LIENS.** Special assessments imposed within the assessment areas listed on the rolls described in Section 4 hereof shall constitute a lien against assessed property equal in rank and dignity with the liens of all state, county, district or municipal taxes and other non-ad valorem assessments. Except as otherwise provided by law, such lien shall be superior in dignity to all other liens, titles and claims, until the ad valorem tax bill for such year is otherwise paid in full pursuant to the Uniform Assessment Collection Act. The lien shall be deemed perfected upon adoption of this Resolution and shall attach to the property included on the assessment roll as of January 1, 2019, the lien date for ad valorem taxes.

**SECTION 6. CONFLICTS.** All prior resolutions or parts of resolutions in conflict herewith are hereby repealed to the extent of such conflict.

**SECTION 7. SEVERABILITY.** If any clause, section, other part or application of this Resolution is held by any court of competent jurisdiction to be unconstitutional or invalid, in part or application, it shall not affect the validity of the remaining portions or applications of this Resolution.

**SECTION 8. EFFECTIVE DATE.** This Resolution shall take effect immediately upon its passage and adoption.



**RESOLVED BY** the City Commission of the City of Winter Springs, Florida, in a regular meeting assembled this 12th day of August, 2019.

**CITY OF WINTER SPRINGS, FLORIDA**

(SEAL)

By: \_\_\_\_\_

Charles Lacey, Mayor

ATTEST:

By: \_\_\_\_\_

Andrea Lorenzo-Luaces, City Clerk

APPROVED AS TO LEGAL FORM AND  
SUFFICIENCY FOR THE CITY OF  
WINTER SPRINGS ONLY:

By: \_\_\_\_\_

Anthony A. Garganese, City Attorney

**CERTIFICATE  
TO  
NON-AD VALOREM ASSESSMENT ROLL**

I HEREBY CERTIFY that, I am the Chair of the City Commission, or authorized agent of the City of Winter Springs, Florida (the "City"); as such I have satisfied myself that all property included or includable on the **Oak Forest Assessment Area Non-Ad Valorem Assessment Roll** (the "Non-Ad Valorem Assessment Roll") for the City is properly assessed so far as I have been able to ascertain; and that all required extensions on the above described roll to show the non-ad valorem assessments attributable to the property listed therein have been made pursuant to law.

I FURTHER CERTIFY that, in accordance with the Uniform Assessment Collection Act, this certificate and the herein described Non-Ad Valorem Assessment Roll will be delivered to the Seminole County Tax Collector by September 15, 2019.

IN WITNESS WHEREOF, I have subscribed this certificate and directed the same to be delivered to the Seminole County Tax Collector and made part of the above described Non-Ad Valorem Assessment Roll this the 12<sup>th</sup> day of August, 2019.

<b>Oak Forest Assessment Area</b>	<b>Total</b>
Maintenance Assessment	
Total Parcels	936
Total Annual Assessment	\$58,047.00

**CITY OF WINTER SPRINGS, FLORIDA**

By: \_\_\_\_\_  
Mayor

**Winter Springs – Oak Forest Service Assessment  
Assessment Summary: 2019 – 2020**

**\$60.00/BU Maintenance Rate**

---

**Maintenance Assessment**

Total BU's .....	967.45
Parcel Count .....	936
Total Maintenance Assessment .....	\$58,047.00

## Oak Forest Wall and Beautification District (OFWBD)

### Fiscal Year 2019-20 Annual Assessment

Owner Name	Parcel ID	Annual Maintenance Assessment	Total Annual Assessment
2017-1 IH BORROWER LP	01-21-30-503-0000-7510	\$60.00	\$60.00
2017-1 IH BORROWER LP	12-21-30-505-0000-3810	60.00	60.00
2018-2 1H BORROWER LP	01-21-30-503-0000-7560	66.00	66.00
2018-2 1H BORROWER LP	12-21-30-506-0000-3990	60.00	60.00
2018-3 IH BORROWER LP	01-21-30-504-0000-8590	60.00	60.00
2018-3 IH BORROWER LP	12-21-30-505-0000-3110	66.00	66.00
2019-1 IH BORROWER LP	12-21-30-505-0000-3150	66.00	66.00
2019-1 IH BORROWER LP	12-21-30-506-0000-4320	60.00	60.00
ABOU, JAOUDE KHALIL & BLANCHE	01-21-30-504-0000-8770	60.00	60.00
ACEVEDO, EDWIN & CRYSTAL	12-21-30-505-0000-3190	75.00	75.00
ACIO, PENNY C & ARVIN	01-21-30-504-0000-8490	60.00	60.00
ADAMMISSION, KRISTOPHER	12-21-30-505-0000-3610	60.00	60.00
ADAMSON, CHRISTOPHER M & REGAN	01-21-30-5JJ-0000-6830	75.00	75.00
ADORNO, JUAN B & ANNA M	01-21-30-503-0000-7230	75.00	75.00
AEDO, JOHN & JENNIFER	12-21-30-506-0000-4160	60.00	60.00
AGUIRRE, GERDA I	12-21-30-5HN-0000-4680	60.00	60.00
ALAI, MOHAMMAD & GILDA A	01-21-30-504-0000-8650	60.00	60.00
ALALOU, DEBORAH & FOUAD	01-21-30-503-0000-7730	66.00	66.00
ALDAY, TERRANCE B & DEBORAH R	12-21-30-505-0000-2790	60.00	60.00
ALDRIDGE, MARTHA J LIFE EST	12-21-30-506-0000-4630	60.00	60.00
ALGERI, THOMAS J & BEINER, JENNIFER L	12-21-30-505-0000-3340	60.00	60.00
ALLEN, DONNA S	12-21-30-501-0000-0640	66.00	66.00
ALLEN, PAUL R & HELLER-ALLEN, CHERYL J & HELLER,	12-21-30-505-0000-3790	60.00	60.00
ALONSO, SLUSARZ JUDY	01-21-30-504-0000-9250	60.00	60.00
ALPHIN, LEONARD H & DIANE	01-21-30-5JJ-0000-6310	66.00	66.00
ALTER, MATTHEW S & AMBER L	01-21-30-5JJ-0000-7100	60.00	60.00
ALVEREZ, MATTHEW B & ANGELA	12-21-30-5HN-0000-5320	60.00	60.00
AMIN, CHANDRA-KANT P & TARLIKABEN C	12-21-30-504-0000-1930	60.00	60.00

## Oak Forest Wall and Beautification District (OFWBD)

### Fiscal Year 2019-20 Annual Assessment

Owner Name	Parcel ID	Annual Maintenance Assessment	Total Annual Assessment
WRIGHT, BEVERLY A	01-21-30-5JJ-0000-6020	60.00	60.00
WYATT, BOBBY W & WOLF, DANETTE S	12-21-30-5HN-0000-4940	60.00	60.00
WYSLUZALY, JOSEPH & ASHTEN	01-21-30-504-0000-9220	60.00	60.00
YAFFEE, DONALD & LINDA M	12-21-30-503-0000-1660	60.00	60.00
YAGER, JASON & MELANIE	12-21-30-504-0000-1720	60.00	60.00
YANNON, LINDA L LIFE EST	12-21-30-505-0000-3590	60.00	60.00
YEATTS, CARA P & JONATHAN R	01-21-30-504-0000-8710	60.00	60.00
YONG, ZHI	01-21-30-504-0000-9230	60.00	60.00
YOUNGGREEN, RICK L	12-21-30-5HN-0000-5560	60.00	60.00
ZEIHER, THEODORE J	01-21-30-504-0000-8140	60.00	60.00
ZORNEK, ESTHER	12-21-30-503-0000-1640	60.00	60.00
ZYAMBO, TELIYA	12-21-30-505-0000-3720	60.00	60.00
<b>Project Totals</b>	<b>936 Parcels</b>	<b>\$58,047.00</b>	<b>\$58,047.00</b>

# Oak Forest Wall and Beautification District (OFWBD)

## Fiscal Year 2019-20 Annual Assessment

Parcel ID	Owner Name	Annual Maintenance Assessment	Total Annual Assessment
01-21-30-503-0000-7160	CHAPELAINE, CHAD & STEPHANIE	\$75.00	\$75.00
01-21-30-503-0000-7170	CAMMACK, MARK W F & HOLTZMAN, AMANDA J	75.00	75.00
01-21-30-503-0000-7180	DAMON, JAMES & LAURA K	75.00	75.00
01-21-30-503-0000-7190	RIVERA, PEDRO J & STEPHANIE M	75.00	75.00
01-21-30-503-0000-7200	CUSHENBERRY, ADRIAN & CHELSEA	75.00	75.00
01-21-30-503-0000-7210	FINLEY, DANIEL M & ZAHIRA	75.00	75.00
01-21-30-503-0000-7220	SANTIAGO, ABIGAIL	75.00	75.00
01-21-30-503-0000-7230	ADORNO, JUAN B & ANNA M	75.00	75.00
01-21-30-503-0000-7240	DEVINE, SCOTT & JENNIFER	75.00	75.00
01-21-30-503-0000-7250	GRANDOWSKI, VICTOR P & ANNA M	75.00	75.00
01-21-30-503-0000-7260	FUDGE, DOUGLAS J & BRECK S	75.00	75.00
01-21-30-503-0000-7270	PARKIN, KEITH E & MATTIE H	75.00	75.00
01-21-30-503-0000-7280	NELSON, DIANE M	75.00	75.00
01-21-30-503-0000-7290	IRIZARRY, JOSE & MIRIAM	75.00	75.00
01-21-30-503-0000-7460	RITZER, BRUCE A & SANDRA L	60.00	60.00
01-21-30-503-0000-7470	HADDOCK, STEVEN J & CAROL I	60.00	60.00
01-21-30-503-0000-7480	O'CALLAGHAN, CHERYL L	60.00	60.00
01-21-30-503-0000-7490	BILL, EDWARD M & DIANA C	60.00	60.00
01-21-30-503-0000-7500	LOVING, MARY L	60.00	60.00
01-21-30-503-0000-7510	2017-1 IH BORROWER LP	60.00	60.00
01-21-30-503-0000-7520	WILLIAMS, STEPHEN W & E	60.00	60.00
01-21-30-503-0000-7530	GONANO, CHARLES L & R JOY	60.00	60.00
01-21-30-503-0000-7540	ATKINS, DOUGLAS E ENH LIFE EST & ATKINS, VIRGINIA	66.00	66.00
01-21-30-503-0000-7550	PASKMAN, KENNETH M & LAURIE M	66.00	66.00
01-21-30-503-0000-7560	2018-2 1H BORROWER LP	66.00	66.00
01-21-30-503-0000-7570	BECK, ROBERT C & PATTY J	66.00	66.00
01-21-30-503-0000-7580	COLON, CARMEN M TR & COLON, JOSE A TR	66.00	66.00
01-21-30-503-0000-7590	DEL BENE, GEOFFREY	66.00	66.00

## Oak Forest Wall and Beautification District (OFWBD)

### Fiscal Year 2019-20 Annual Assessment

Parcel ID	Owner Name	Annual Maintenance Assessment	Total Annual Assessment
12-21-30-5HN-0000-5500	JACKSON, SHANE C & LARA J	60.00	60.00
12-21-30-5HN-0000-5510	SCHROEDER, JOHN S L & CRYSTAL L	60.00	60.00
12-21-30-5HN-0000-5520	REYOME, GERALD R & JULIE A	60.00	60.00
12-21-30-5HN-0000-5530	HALE, JOSEPH C & MARY E	60.00	60.00
12-21-30-5HN-0000-5540	QUIROZ, MARCO A & MORA, CLAUDIA N	60.00	60.00
12-21-30-5HN-0000-5550	MONTI, JOSEPH J & ROBIN S	60.00	60.00
12-21-30-5HN-0000-5560	YOUNGGREEN, RICK L	60.00	60.00
12-21-30-5HN-0000-5570	MANIS, HARRIET J	60.00	60.00
12-21-30-5HN-0000-5580	SMITH, DAVID A & REYNOLDS, SUSAN L	60.00	60.00
12-21-30-5HN-0000-5590	BURCH, KEVIN R & HUNTER, LINDA M	60.00	60.00
12-21-30-5HN-0000-5600	MELLENDEZ, CARLOS LIFE EST	60.00	60.00
12-21-30-5HN-0000-5610	GOREN, KENNETH P CO-TRS & ROSE, DONNA K CO-TRS	60.00	60.00
<b>Project Totals</b>	<b>936 Parcels</b>	<b>\$58,047.00</b>	<b>\$58,047.00</b>

**CERTIFICATE  
TO  
NON-AD VALOREM ASSESSMENT ROLL**

I HEREBY CERTIFY that, I am the Chair of the City Commission, or authorized agent of the City of Winter Springs, Florida (the "City"); as such I have satisfied myself that all property included or includable on the **Tusawilla Service and Improvement Areas Non-Ad Valorem Assessment Roll** (the "Non-Ad Valorem Assessment Roll") for the City is properly assessed so far as I have been able to ascertain; and that all required extensions on the above described roll to show the non-ad valorem assessments attributable to the property listed therein have been made pursuant to law.

I FURTHER CERTIFY that, in accordance with the Uniform Assessment Collection Act, this certificate and the herein described Non-Ad Valorem Assessment Roll will be delivered to the Seminole County Tax Collector by September 15, 2019.

IN WITNESS WHEREOF, I have subscribed this certificate and directed the same to be delivered to the Seminole County Tax Collector and made part of the above described Non-Ad Valorem Assessment Roll this the 12<sup>th</sup> day of August, 2019.

<b>Tusawilla Service and Improvement Assessment Area</b>	<b>Total</b>
Phase I Improvement Assessment	
Total Parcels	4,200
Phase I Improvement Total Annual Assessment	\$144,432.00
Maintenance Assessment	
Total Parcels	4,617
Total Maintenance Annual Assessment	\$528,696.00

**CITY OF WINTER SPRINGS, FLORIDA**

By: \_\_\_\_\_  
Mayor



**Winter Springs – Tuscawillia Improvement and Service Assessments**  
**Assessment Summary: 2019 – 2020**

**\$36.00/ERU Phase I Improvement Rate & \$120.00/ERU Maintenance Rate**

---

**Improvement Assessment Phase I**

Total ERU's .....	4,012.00
Parcel Count .....	4,200
Total Annual Assessment .....	\$144,432.00

**Maintenance Assessment**

Total ERU's .....	4,405.80
Parcel Count.....	4,617
Total Maintenance Assessment.....	\$528,696.00

## Tusawilla Lighting and Beautification Assessment Area (TLBAA)

### Fiscal Year 2019-20 Annual Assessment

Owner Name	Parcel ID	Annual Improvement Assessment Phase 1	Annual Maintenance Assessment	Total Annual Assessment
(M), TUCKER PAMELA & MURPHY, MARK A	13-21-30-503-0000-0450	\$36.00	\$120.00	\$156.00
1000 GATOR LANE LLC	13-21-30-503-0000-0410	0.00	120.00	120.00
122 PEREGRINE CT LLC	05-21-31-504-0000-0650	0.00	120.00	120.00
1315 AUGUSTA NATIONAL LLC	07-21-31-5FN-0000-2000	36.00	120.00	156.00
1418 FOREST HILLS LLC	07-21-31-507-0000-0970	36.00	120.00	156.00
19991009 REVOCABLE TRUST	07-21-31-510-0000-0510	36.00	120.00	156.00
2017-1 IH BORROWER LP	07-21-31-503-0000-0350	36.00	120.00	156.00
2017-1 IH BORROWER LP	07-21-31-518-0000-1160	36.00	120.00	156.00
2017-2 IH BORROWER LP	18-21-31-506-0000-0120	36.00	120.00	156.00
2018-2 1H BORROWER LP	07-21-31-505-0000-1240	36.00	120.00	156.00
2018-2 1H BORROWER LP	12-21-30-5DA-0000-3290	36.00	120.00	156.00
2018-3 IH BORROWER LP	12-21-30-5DA-0000-2510	36.00	120.00	156.00
2018-3 IH BORROWER LP	18-21-31-501-0000-1200	36.00	120.00	156.00
2019-1 IH BORROWER LP	07-21-31-507-0000-0220	36.00	120.00	156.00
319 WOODLEAF LLC	07-21-31-518-0000-0680	36.00	120.00	156.00
600 NORTHERN WAY #404 LLC	07-21-31-506-0400-004H	0.00	72.00	72.00
603 CPCD LLC	07-21-31-5GY-0900-0020	21.60	72.00	93.60
933 OLD WHITE WAY LLC	07-21-31-511-0000-1470	36.00	120.00	156.00
947 TORREY PINE LLC	07-21-31-511-0000-1320	0.00	120.00	120.00
985 TROON TRCE LLC	18-21-31-506-0000-0110	36.00	120.00	156.00
AAKEBERG, GERAL A & JUDITH A	08-21-31-5HS-0000-0700	36.00	120.00	156.00
ABELL, RANDOLPH A & SHERRY L	08-21-31-507-0000-0220	36.00	120.00	156.00
ABERNATHY, NINA J	05-21-31-504-0000-0660	36.00	120.00	156.00
ABLANEDO, CARLOS M	08-21-31-5GT-0000-0360	36.00	120.00	156.00
ABOUD, ROBERT D & COLLEEN	05-21-31-504-0000-0950	36.00	120.00	156.00
ABRAHAMIAN, EMIL V TR & ABRAHAMIAN, SUSAN D	07-21-31-518-0000-0230	36.00	120.00	156.00
ABREU, BARBARA L TR	07-21-31-517-0000-1890	36.00	120.00	156.00
ACEVEDO, DAMASO & MARIA	12-21-30-5DA-0000-3060	36.00	120.00	156.00

# Tusawilla Lighting and Beautification Assessment Area (TLBAA)

## Fiscal Year 2019-20 Annual Assessment

Owner Name	Parcel ID	Annual Improvement Assessment Phase 1	Annual Maintenance Assessment	Total Annual Assessment
ZAGAR, THOMAS W & PAULA J	08-21-31-507-0000-0450	0.00	120.00	120.00
ZAJAC, THOMAS S LIFE EST & ZAJAC, JANET M LIFE EST	07-21-31-5FN-0000-1890	36.00	120.00	156.00
ZAMBRANA, GISELE J	07-21-31-517-0000-2280	36.00	120.00	156.00
ZAMMIT, DAVID A	12-21-30-5EK-0000-0500	36.00	120.00	156.00
ZAPATA, STACY L & ALEJANDRO	08-21-31-506-0000-0910	36.00	120.00	156.00
ZARNANI, VAHID	07-21-31-507-0000-1930	36.00	120.00	156.00
ZARNOWSKI, TERENCE C & LINDA J	08-21-31-504-0000-0850	36.00	120.00	156.00
ZARTMAN, DAVID M & MARGARET D	18-21-31-501-0000-1180	36.00	120.00	156.00
ZAYAS, ALEXANDER & BRITTANY	07-21-31-507-0000-1570	36.00	120.00	156.00
ZHOU, JING & LIU, FENQIANG	18-21-31-513-0000-0230	36.00	120.00	156.00
ZIEGLER, JOANNE L	07-21-31-502-0000-0820	36.00	120.00	156.00
ZIELINSKI, LAN	07-21-31-511-0000-1540	36.00	120.00	156.00
ZIMERI, MARIBEL & VONEISENBERG, JOHANN	07-21-31-5MW-0000-0090	36.00	120.00	156.00
ZIMMERMAN, JEFFREY J & CAROL A	18-21-31-513-0000-0190	36.00	120.00	156.00
ZIMORSKI, ESTHER L TR	18-21-31-506-0000-0580	36.00	120.00	156.00
ZINSSAR, MICHAEL R LIFE EST & ZINSSAR, LAUREL R	07-21-31-511-0000-1240	36.00	120.00	156.00
ZIPAY, PETER J & LAURA A	05-21-31-5NF-0000-1360	36.00	120.00	156.00
ZISCHKAU, ERIC E TR & ZISCHKAU, JONATHAN D TR	07-21-31-5FQ-0000-1560	0.00	120.00	120.00
ZITO, MELISSA G	07-21-31-5GY-2100-0050	21.60	72.00	93.60
ZMIJEWSKI, DONNA S & MICHAEL E	07-21-31-5GB-0000-0520	36.00	120.00	156.00
ZOOK, DONALD J & JOANNA K	07-21-31-514-0000-0010	36.00	120.00	156.00
ZUBARIK, LESLIE & JASON	12-21-30-5DA-0000-3870	36.00	120.00	156.00
ZVARYCH, ADRIAN G & SHARON I	07-21-31-506-0700-007E	21.60	72.00	93.60
ZWISSLER, CHESTER J & ELLEN	07-21-31-507-0000-1370	36.00	120.00	156.00
ZYDORSKI, DAVID S	07-21-31-507-0000-0370	36.00	120.00	156.00
<b>Project Totals</b>	<b>4,617 Parcels</b>	<b>\$144,432.00</b>	<b>\$528,696.00</b>	<b>\$673,128.00</b>

## Tuscawilla Lighting and Beautification Assessment Area (TLBAA)

### Fiscal Year 2019-20 Annual Assessment

Parcel ID	Owner Name	Annual Improvement Assessment Phase 1	Annual Maintenance Assessment	Total Annual Assessment
01-21-30-5BH-0000-0790	C&B CAPITAL VENTURES LLC	\$97.92	\$326.40	\$424.32
01-21-30-5BH-0000-0830	WESTBURY REALTY GROUP INC	46.80	156.00	202.80
01-21-30-5BH-0000-083A	BRYCE FOSTER CORP	36.00	120.00	156.00
05-21-31-502-0000-0010	WALSH, HELEN J	36.00	120.00	156.00
05-21-31-502-0000-0020	KELLEY, LISA, HUGH A & GRACE	36.00	120.00	156.00
05-21-31-502-0000-0030	NOGUES, JULIEN V & AMANDA G	36.00	120.00	156.00
05-21-31-502-0000-0040	DORAN, SHEILA A & MAXWELL, PATRICIA W	36.00	120.00	156.00
05-21-31-502-0000-0050	FINOCCHIO, JOHN R & CATHERINE H	36.00	120.00	156.00
05-21-31-502-0000-0060	KERR, DAVID L & JONES, ELIZABETH A	36.00	120.00	156.00
05-21-31-502-0000-0070	RAIA, JOSEPH P & CARMEN	36.00	120.00	156.00
05-21-31-502-0000-0080	MCFADDEN, OMELLA	36.00	120.00	156.00
05-21-31-502-0000-0090	VOIGHT, DIANE S	36.00	120.00	156.00
05-21-31-502-0000-0100	LATOUR, JADE & JOSHUA	36.00	120.00	156.00
05-21-31-502-0000-0110	TOM, KAMAL & KALLUMADIKAL	36.00	120.00	156.00
05-21-31-502-0000-0120	NOONAN, JOHN G	36.00	120.00	156.00
05-21-31-502-0000-0130	PRIEST, TARA	36.00	120.00	156.00
05-21-31-502-0000-0140	FERTIG, HESTON A & ELIZABETH A	0.00	120.00	120.00
05-21-31-502-0000-0150	GRANGER, WAYNE A	36.00	120.00	156.00
05-21-31-502-0000-0160	TABSCOTT, MICHELLE L	36.00	120.00	156.00
05-21-31-502-0000-0170	SCHMIT, RAYMOND J TR & SCHMIT, HELEN G TR	36.00	120.00	156.00
05-21-31-502-0000-0180	NORRIS, RUBY G LIFE EST & NORRIS, TRACY L LIFE EST	0.00	120.00	120.00
05-21-31-502-0000-0190	SENECA, ALBERT & MORAN, SONNIA	36.00	120.00	156.00
05-21-31-502-0000-0200	REHNSTROM, RICHARD G	36.00	120.00	156.00
05-21-31-502-0000-0210	KAMINSKI, TIFFANY N	36.00	120.00	156.00
05-21-31-502-0000-0220	BRYANT, TONY J & KIM C	36.00	120.00	156.00
05-21-31-502-0000-0230	MCDANIEL, MARGARET M	36.00	120.00	156.00
05-21-31-502-0000-0240	CLARSON, GERALDINE T & MELICHAR, CAROL A	36.00	120.00	156.00
05-21-31-502-0000-0250	MITCHELL, DANA R	36.00	120.00	156.00
05-21-31-502-0000-0260	DASILVEIRA, NICOLE	36.00	120.00	156.00

## Tuscawilla Lighting and Beautification Assessment Area (TLBAA)

### Fiscal Year 2019-20 Annual Assessment

Parcel ID	Owner Name	Annual Improvement Assessment Phase 1	Annual Maintenance Assessment	Total Annual Assessment
18-21-31-5ET-0000-0750	WHITEMAN, JO ANN TR	36.00	120.00	156.00
18-21-31-5ET-0000-0760	ADGAR, DEVOLINE	36.00	120.00	156.00
18-21-31-5ET-0000-0770	MCCUE, DANIEL & KELI	36.00	120.00	156.00
18-21-31-5ET-0000-0780	MCLEAN, DANIEL L & EMILY J	36.00	120.00	156.00
18-21-31-5ET-0000-0790	PETTIT, JAMES F JR & VERONICA M A	36.00	120.00	156.00
31-20-31-5BB-0000-004A	TUSCAWILLA GOLF CLUB LLC	596.88	1,989.60	2,586.48
<b>Project Totals</b>	<b>4,617 Parcels</b>	<b>\$144,432.00</b>	<b>\$528,696.00</b>	<b>\$673,128.00</b>

**CERTIFICATE  
TO  
NON-AD VALOREM ASSESSMENT ROLL**

I HEREBY CERTIFY that, I am the Chair of the City Commission, or authorized agent of the City of Winter Springs, Florida (the "City"); as such I have satisfied myself that all property included or includable on the **Tusawilla Units 12/12A Service and Improvement Areas Non-Ad Valorem Assessment Roll** (the "Non-Ad Valorem Assessment Roll") for the City is properly assessed so far as I have been able to ascertain; and that all required extensions on the above described roll to show the non-ad valorem assessments attributable to the property listed therein have been made pursuant to law.

I FURTHER CERTIFY that, in accordance with the Uniform Assessment Collection Act, this certificate and the herein described Non-Ad Valorem Assessment Roll will be delivered to the Seminole County Tax Collector by September 15, 2019.

IN WITNESS WHEREOF, I have subscribed this certificate and directed the same to be delivered to the Seminole County Tax Collector and made part of the above described Non-Ad Valorem Assessment Roll this the 12<sup>th</sup> day of August, 2019.

<b>Tusawilla Units 12/12A Service and Improvement Assessment Area</b>	<b>Total</b>
Units 12/12A Improvement Assessment	
Total Parcels	67
Units 12/12A Improvement Total Annual Assessment	\$5,933.00
Units 12/12A Maintenance Assessment	
Total Parcels	86
Units 12/12A Maintenance Total Annual Assessment	\$7,812.60

**CITY OF WINTER SPRINGS, FLORIDA**

By: \_\_\_\_\_  
Mayor

**Winter Springs – Tuscawilla Units 12/12A Improvement and Maintenance Assessments**

**Assessment Summary: 2019 – 2020**

**Units 12/12A Improvement Rate \$85.00/BU & Maintenance Rate & \$87.00/BU Maintenance Rate**

---

**Units 12/12A Improvement Assessment**

Total BU's .....	69.80
Parcel Count .....	67
Total Annual Assessment .....	\$5,933.00

**Units 12/12A Maintenance Assessment**

Total BU's .....	89.80
Parcel Count.....	86
Total Maintenance Assessment.....	\$7,812.60

## Tuscawilla Units 12/12A Assessment Area

## Fiscal Year 2019-20 Annual Assessment

Owner Name	Parcel ID	Annual Improvement Assessment	Annual Maintenance Assessment	Total Annual Assessment
ABLANEDO, CARLOS M	08-21-31-5GT-0000-0360	\$102.00	\$104.40	\$206.40
BAKER, THEODORE A & MELINDA R	08-21-31-5GT-0000-0270	85.00	87.00	172.00
BEAR, CHERYL A CO-TRS & BEAR, JONATHAN R CO-TRS	08-21-31-502-0000-0030	85.00	87.00	172.00
BIVONA, THERESA A TR	08-21-31-5GT-0000-0150	0.00	87.00	87.00
BOGGS, JEFFREY D & KATHRYN M	08-21-31-5GT-0000-0680	102.00	104.40	206.40
BOLDT, DAVID W & SHARON	08-21-31-5GT-0000-0330	85.00	87.00	172.00
BORCK, NANCY L	08-21-31-5GT-0000-0260	85.00	87.00	172.00
BROOK, MARY A & BROOK, KAREN L GDN & BROOK, JOYCE	08-21-31-5GT-0000-0470	85.00	87.00	172.00
BUTLER, STEVEN V & KATHLEEN G	08-21-31-5GT-0000-0200	0.00	87.00	87.00
CALABRO, STEPHEN H & JODY A	08-21-31-5GT-0000-0340	85.00	87.00	172.00
CAMARANO, MICHAEL & LORRAINE R	08-21-31-5GT-0000-0410	85.00	87.00	172.00
CAMPBELL, JAMES & ELIZABETH	08-21-31-5GT-0000-0450	0.00	104.40	104.40
CANNISTRACI, RUSSELL L & DEENA	08-21-31-5GT-0000-0720	0.00	87.00	87.00
CHERRY, WINGATE FELICE & WINGATE, DARRYL	08-21-31-5GT-0000-0650	102.00	104.40	206.40
CIUPIK, JOHN J & BARBARA J	08-21-31-5GT-0000-0540	85.00	87.00	172.00
COOKSEY, NORMA M LIFE EST	08-21-31-502-0000-0800	0.00	87.00	87.00
CURRAN, JAMES C & STEPHANIE A	08-21-31-5GT-0000-0620	85.00	87.00	172.00
CUTLER, JAMES I LIFE EST & CUTLER, BARBARA G LIFE	08-21-31-5GT-0000-0080	85.00	87.00	172.00
DIAZ, ARIEL & VITERI, JANETH	08-21-31-5GT-0000-0040	85.00	87.00	172.00
DUBOIS, GARY S & BERNADETTE M	08-21-31-502-0000-0770	85.00	87.00	172.00
FEHR, STEVEN E	08-21-31-5GT-0000-0070	0.00	87.00	87.00
FRILEN ANNABELLE W REV TRUST	08-21-31-502-0000-0010	102.00	104.40	206.40
FROELICH, ALLEN K TR & FROELICH, THERESA E TR	08-21-31-5GT-0000-0180	85.00	87.00	172.00
GALVIN, MARK P & SUSAN M	08-21-31-5GT-0000-0110	85.00	87.00	172.00
GERMAN, MARK F & THERESA M	08-21-31-5GT-0000-0400	85.00	87.00	172.00
GISH, KURT A & MARIA D	08-21-31-5GT-0000-0380	85.00	87.00	172.00
GOMEZ, COLLEEN M C & DELGADO GOMEZ, MARTIN D	08-21-31-502-0000-0790	0.00	87.00	87.00
GREENBERG, KENNETH C & NANCY	08-21-31-5GT-0000-0660	0.00	104.40	104.40
GUILFOYLE, CHRISTEN & RICHARD & DEAMICIS, DENISE	08-21-31-502-0000-0780	85.00	87.00	172.00
HALL, STEVEN M & ULRICA	08-21-31-5GT-0000-0550	85.00	87.00	172.00
HARPER, ELIZABETH & LUNDY, MARILYN	08-21-31-502-0000-0020	85.00	87.00	172.00
HESS, LINDA P	08-21-31-5GT-0000-0700	0.00	87.00	87.00
HORAN, JOHN P & JOETTE Y	08-21-31-5GT-0000-0230	85.00	87.00	172.00
HUGH, SAM PAUL & DEBRA F	08-21-31-5GT-0000-0510	85.00	87.00	172.00
JACOBS, JASON J & SHANNON L	08-21-31-5GT-0000-0730	85.00	87.00	172.00
JACOBS, ROBERT M & JOYCE C	08-21-31-5GT-0000-0710	0.00	87.00	87.00



## Tuscawilla Units 12/12A Assessment Area

### Fiscal Year 2019-20 Annual Assessment

Owner Name	Parcel ID	Annual Improvement Assessment	Annual Maintenance Assessment	Total Annual Assessment
JOHNSTON, LAWRENCE W & ELLEN M	08-21-31-502-0000-0870	102.00	104.40	206.40
JONES, TIMOTHY A & TRACY M	08-21-31-5GT-0000-0530	0.00	104.40	104.40
JUGE, MATTHEW K & SUSAN W	08-21-31-5GT-0000-0290	85.00	87.00	172.00
KENNEDY, SONIA TR	08-21-31-5GT-0000-0160	85.00	87.00	172.00
KENNY, MARY A	08-21-31-5GT-0000-0580	85.00	87.00	172.00
KERSZULIS, WALTER J & JOANNE F	08-21-31-5GT-0000-0690	85.00	87.00	172.00
KRAMER, BONNIE L TR	08-21-31-5GT-0000-0130	85.00	87.00	172.00
LAMB, JAMES T & JUDITH M	08-21-31-5GT-0000-0220	85.00	87.00	172.00
LEE, JONATHAN W & SYLVIA P	08-21-31-502-0000-0830	102.00	104.40	206.40
LEWIS, ROGER E TR & LEWIS, KATHLEEN A TR	08-21-31-5GT-0000-0090	85.00	87.00	172.00
LINDSAY, LEE N & KATHY L	08-21-31-5GT-0000-0520	102.00	104.40	206.40
LYKKEBAK, JOHN D	08-21-31-5GT-0000-0440	85.00	87.00	172.00
MACLAREN, JOSEPH A & TREVOR M	08-21-31-5GT-0000-0560	85.00	87.00	172.00
MARTIN, ROBERT J & KIMBRAUGH	08-21-31-5GT-0000-0140	85.00	87.00	172.00
MC COWN, WILLIAM R & DARLENE M	08-21-31-5GT-0000-0250	0.00	87.00	87.00
MCCANN, THOMAS J & DONNA R	08-21-31-5GT-0000-0490	85.00	87.00	172.00
MILLER, ROBERT & JEAN	08-21-31-5GT-0000-0350	102.00	104.40	206.40
MIZE, VINCENT D & WENDY A	08-21-31-5GT-0000-0420	85.00	87.00	172.00
MULLIGAN, JAMES B & NICOLE M	08-21-31-5GT-0000-0640	102.00	104.40	206.40
NAEGELE, STEPHANIE G	08-21-31-5GT-0000-0050	85.00	87.00	172.00
NELSON, ZACHARIAH J & CANDICE M	08-21-31-502-0000-0810	102.00	104.40	206.40
PABIAN, MEGAN & PATRICK	08-21-31-5GT-0000-0480	0.00	87.00	87.00
PEERY, SANDRA K	08-21-31-5GT-0000-0390	85.00	87.00	172.00
PONCE, JOHN A & MIRIAM R	08-21-31-5GT-0000-0570	85.00	87.00	172.00
ROOP, ROBERT L & MYRA L	08-21-31-502-0000-0840	102.00	104.40	206.40
RYAN, MARY E TR	08-21-31-5GT-0000-0670	102.00	104.40	206.40
RYNEARSON, ANDREW	08-21-31-5GT-0000-0610	85.00	87.00	172.00
SCHERWIN, RACHEL E & JEFFREY D	08-21-31-5GT-0000-0750	85.00	87.00	172.00
SHEIKH, MEHRDAD & VIRGINIA	08-21-31-5GT-0000-0120	85.00	87.00	172.00
SIMPSON, MARK	08-21-31-502-0000-0850	102.00	104.40	206.40
SINGH, MARIE L	08-21-31-5GT-0000-0300	0.00	87.00	87.00
SLOAN, CHARLES D & DIANE E	08-21-31-5GT-0000-0210	85.00	87.00	172.00
SMITH, DAVID J & SHELLI D	08-21-31-5GT-0000-0060	85.00	87.00	172.00
STEENSON, ROBERT L & KATHLEEN V	08-21-31-5GT-0000-0600	85.00	87.00	172.00
SUNDMAN, JOHN C & JOYCE L	08-21-31-502-0000-0860	102.00	104.40	206.40
SWAN, ROBERT A	08-21-31-5GT-0000-0240	85.00	87.00	172.00

## Tuscawilla Units 12/12A Assessment Area

### Fiscal Year 2019-20 Annual Assessment

Owner Name	Parcel ID	Annual Improvement Assessment	Annual Maintenance Assessment	Total Annual Assessment
SZAKOVITS, WILLIAM G LIFE EST & SZAKOVITS, JANET D	08-21-31-5GT-0000-0460	0.00	104.40	104.40
TAYLOR, AARON & SAREET	08-21-31-502-0000-0820	0.00	104.40	104.40
TAYLOR, JAMES S	08-21-31-5GT-0000-0320	0.00	87.00	87.00
TEETSEL, ROBERT C & ANGELA L	08-21-31-5GT-0000-0190	85.00	87.00	172.00
TERRY, JOHN R & JOAN B	08-21-31-5GT-0000-0100	0.00	87.00	87.00
THIEL, FRANCISCO A & MARIA C	08-21-31-502-0000-0760	0.00	87.00	87.00
TUCK, JENNA G & ALEXANDER F	08-21-31-5GT-0000-0590	85.00	87.00	172.00
TYLER, FORCIA	08-21-31-5GT-0000-0280	85.00	87.00	172.00
VEGA, JOSE A & ALMA L	08-21-31-5GT-0000-0370	85.00	87.00	172.00
VERNAU, JOSEPH R & DEBORAH E	08-21-31-5GT-0000-0500	85.00	87.00	172.00
WALTERS, MARK & ELIZABETH	08-21-31-5GT-0000-0430	85.00	87.00	172.00
WALTHER, KEVIN & JESSICA	08-21-31-5GT-0000-0740	85.00	87.00	172.00
WILSON, GREGORY A & CORTES, WILSON NURIA	08-21-31-5GT-0000-0630	85.00	87.00	172.00
WOODCOCK, ANDREW T & MARY B	08-21-31-5GT-0000-0170	85.00	87.00	172.00
<b>Project Totals</b>	<b>86 Parcels</b>	<b>\$5,933.00</b>	<b>\$7,812.60</b>	<b>\$13,745.60</b>

## Tuscawilla Units 12/12A Assessment Area

### Fiscal Year 2019-20 Annual Assessment

Parcel ID	Owner Name	Annual Improvement Assessment	Annual Maintenance Assessment	Total Annual Assessment
08-21-31-502-0000-0010	FRILEN ANNABELLE W REV TRUST	\$102.00	\$104.40	\$206.40
08-21-31-502-0000-0020	HARPER, ELIZABETH & LUNDY, MARILYN	85.00	87.00	172.00
08-21-31-502-0000-0030	BEAR, CHERYL A CO-TRS & BEAR, JONATHAN R CO-TRS	85.00	87.00	172.00
08-21-31-502-0000-0760	THIEL, FRANCISCO A & MARIA C	0.00	87.00	87.00
08-21-31-502-0000-0770	DUBOIS, GARY S & BERNADETTE M	85.00	87.00	172.00
08-21-31-502-0000-0780	GUILFOYLE, CHRISTEN & RICHARD & DEAMICIS, DENISE	85.00	87.00	172.00
08-21-31-502-0000-0790	GOMEZ, COLLEEN M C & DELGADO GOMEZ, MARTIN D	0.00	87.00	87.00
08-21-31-502-0000-0800	COOKSEY, NORMA M LIFE EST	0.00	87.00	87.00
08-21-31-502-0000-0810	NELSON, ZACHARIAH J & CANDICE M	102.00	104.40	206.40
08-21-31-502-0000-0820	TAYLOR, AARON & SAREET	0.00	104.40	104.40
08-21-31-502-0000-0830	LEE, JONATHAN W & SYLVIA P	102.00	104.40	206.40
08-21-31-502-0000-0840	ROOP, ROBERT L & MYRA L	102.00	104.40	206.40
08-21-31-502-0000-0850	SIMPSON, MARK	102.00	104.40	206.40
08-21-31-502-0000-0860	SUNDMAN, JOHN C & JOYCE L	102.00	104.40	206.40
08-21-31-502-0000-0870	JOHNSTON, LAWRENCE W & ELLEN M	102.00	104.40	206.40
08-21-31-5GT-0000-0040	DIAZ, ARIEL & VITERI, JANETH	85.00	87.00	172.00
08-21-31-5GT-0000-0050	NAEGELE, STEPHANIE G	85.00	87.00	172.00
08-21-31-5GT-0000-0060	SMITH, DAVID J & SHELLI D	85.00	87.00	172.00
08-21-31-5GT-0000-0070	FEHR, STEVEN E	0.00	87.00	87.00
08-21-31-5GT-0000-0080	CUTLER, JAMES I LIFE EST & CUTLER, BARBARA G LIFE	85.00	87.00	172.00
08-21-31-5GT-0000-0090	LEWIS, ROGER E TR & LEWIS, KATHLEEN A TR	85.00	87.00	172.00
08-21-31-5GT-0000-0100	TERRY, JOHN R & JOAN B	0.00	87.00	87.00
08-21-31-5GT-0000-0110	GALVIN, MARK P & SUSAN M	85.00	87.00	172.00
08-21-31-5GT-0000-0120	SHEIKH, MEHRDAD & VIRGINIA	85.00	87.00	172.00
08-21-31-5GT-0000-0130	KRAMER, BONNIE L TR	85.00	87.00	172.00
08-21-31-5GT-0000-0140	MARTIN, ROBERT J & KIMBRAUGH	85.00	87.00	172.00
08-21-31-5GT-0000-0150	BIVONA, THERESA A TR	0.00	87.00	87.00
08-21-31-5GT-0000-0160	KENNEDY, SONIA TR	85.00	87.00	172.00
08-21-31-5GT-0000-0170	WOODCOCK, ANDREW T & MARY B	85.00	87.00	172.00
08-21-31-5GT-0000-0180	FROEHLICH, ALLEN K TR & FROEHLICH, THERESA E TR	85.00	87.00	172.00
08-21-31-5GT-0000-0190	TEETSEL, ROBERT C & ANGELA L	85.00	87.00	172.00
08-21-31-5GT-0000-0200	BUTLER, STEVEN V & KATHLEEN G	0.00	87.00	87.00
08-21-31-5GT-0000-0210	SLOAN, CHARLES D & DIANE E	85.00	87.00	172.00
08-21-31-5GT-0000-0220	LAMB, JAMES T & JUDITH M	85.00	87.00	172.00
08-21-31-5GT-0000-0230	HORAN, JOHN P & JOETTE Y	85.00	87.00	172.00
08-21-31-5GT-0000-0240	SWAN, ROBERT A	85.00	87.00	172.00

## Tuscawilla Units 12/12A Assessment Area

### Fiscal Year 2019-20 Annual Assessment

Parcel ID	Owner Name	Annual Improvement Assessment	Annual Maintenance Assessment	Total Annual Assessment
08-21-31-5GT-0000-0250	MC COWN, WILLIAM R & DARLENE M	0.00	87.00	87.00
08-21-31-5GT-0000-0260	BORCK, NANCY L	85.00	87.00	172.00
08-21-31-5GT-0000-0270	BAKER, THEODORE A & MELINDA R	85.00	87.00	172.00
08-21-31-5GT-0000-0280	TYLER, FORCIA	85.00	87.00	172.00
08-21-31-5GT-0000-0290	JUGE, MATTHEW K & SUSAN W	85.00	87.00	172.00
08-21-31-5GT-0000-0300	SINGH, MARIE L	0.00	87.00	87.00
08-21-31-5GT-0000-0320	TAYLOR, JAMES S	0.00	87.00	87.00
08-21-31-5GT-0000-0330	BOLDT, DAVID W & SHARON	85.00	87.00	172.00
08-21-31-5GT-0000-0340	CALABRO, STEPHEN H & JODY A	85.00	87.00	172.00
08-21-31-5GT-0000-0350	MILLER, ROBERT & JEAN	102.00	104.40	206.40
08-21-31-5GT-0000-0360	ABLANEDO, CARLOS M	102.00	104.40	206.40
08-21-31-5GT-0000-0370	VEGA, JOSE A & ALMA L	85.00	87.00	172.00
08-21-31-5GT-0000-0380	GISH, KURT A & MARIA D	85.00	87.00	172.00
08-21-31-5GT-0000-0390	PEERY, SANDRA K	85.00	87.00	172.00
08-21-31-5GT-0000-0400	GERMAN, MARK F & THERESA M	85.00	87.00	172.00
08-21-31-5GT-0000-0410	CAMARANO, MICHAEL & LORRAINE R	85.00	87.00	172.00
08-21-31-5GT-0000-0420	MIZE, VINCENT D & WENDY A	85.00	87.00	172.00
08-21-31-5GT-0000-0430	WALTERS, MARK & ELIZABETH	85.00	87.00	172.00
08-21-31-5GT-0000-0440	LYKKEBAK, JOHN D	85.00	87.00	172.00
08-21-31-5GT-0000-0450	CAMPBELL, JAMES & ELIZABETH	0.00	104.40	104.40
08-21-31-5GT-0000-0460	SZAKOVITS, WILLIAM G LIFE EST & SZAKOVITS, JANET D	0.00	104.40	104.40
08-21-31-5GT-0000-0470	BROOK, MARY A & BROOK, KAREN L GDN & BROOK, JOYCE	85.00	87.00	172.00
08-21-31-5GT-0000-0480	PABIAN, MEGAN & PATRICK	0.00	87.00	87.00
08-21-31-5GT-0000-0490	MCCANN, THOMAS J & DONNA R	85.00	87.00	172.00
08-21-31-5GT-0000-0500	VERNAU, JOSEPH R & DEBORAH E	85.00	87.00	172.00
08-21-31-5GT-0000-0510	HUGH, SAM PAUL & DEBRA F	85.00	87.00	172.00
08-21-31-5GT-0000-0520	LINDSAY, LEE N & KATHY L	102.00	104.40	206.40
08-21-31-5GT-0000-0530	JONES, TIMOTHY A & TRACY M	0.00	104.40	104.40
08-21-31-5GT-0000-0540	CIUPIK, JOHN J & BARBARA J	85.00	87.00	172.00
08-21-31-5GT-0000-0550	HALL, STEVEN M & ULRICA	85.00	87.00	172.00
08-21-31-5GT-0000-0560	MACLAREN, JOSEPH A & TREVOR M	85.00	87.00	172.00
08-21-31-5GT-0000-0570	PONCE, JOHN A & MIRIAM R	85.00	87.00	172.00
08-21-31-5GT-0000-0580	KENNY, MARY A	85.00	87.00	172.00
08-21-31-5GT-0000-0590	TUCK, JENNA G & ALEXANDER F	85.00	87.00	172.00
08-21-31-5GT-0000-0600	STEENSON, ROBERT L & KATHLEEN V	85.00	87.00	172.00
08-21-31-5GT-0000-0610	RYNEARSON, ANDREW	85.00	87.00	172.00

## Tuscawilla Units 12/12A Assessment Area

### Fiscal Year 2019-20 Annual Assessment

Parcel ID	Owner Name	Annual Improvement Assessment	Annual Maintenance Assessment	Total Annual Assessment
08-21-31-5GT-0000-0620	CURRAN, JAMES C & STEPHANIE A	85.00	87.00	172.00
08-21-31-5GT-0000-0630	WILSON, GREGORY A & CORTES, WILSON NURIA	85.00	87.00	172.00
08-21-31-5GT-0000-0640	MULLIGAN, JAMES B & NICOLE M	102.00	104.40	206.40
08-21-31-5GT-0000-0650	CHERRY, WINGATE FELICE & WINGATE, DARRYL	102.00	104.40	206.40
08-21-31-5GT-0000-0660	GREENBERG, KENNETH C & NANCY	0.00	104.40	104.40
08-21-31-5GT-0000-0670	RYAN, MARY E TR	102.00	104.40	206.40
08-21-31-5GT-0000-0680	BOGGS, JEFFREY D & KATHRYN M	102.00	104.40	206.40
08-21-31-5GT-0000-0690	KERSZULIS, WALTER J & JOANNE F	85.00	87.00	172.00
08-21-31-5GT-0000-0700	HESS, LINDA P	0.00	87.00	87.00
08-21-31-5GT-0000-0710	JACOBS, ROBERT M & JOYCE C	0.00	87.00	87.00
08-21-31-5GT-0000-0720	CANNISTRACI, RUSSELL L & DEENA	0.00	87.00	87.00
08-21-31-5GT-0000-0730	JACOBS, JASON J & SHANNON L	85.00	87.00	172.00
08-21-31-5GT-0000-0740	WALTHER, KEVIN & JESSICA	85.00	87.00	172.00
08-21-31-5GT-0000-0750	SCHERWIN, RACHEL E & JEFFREY D	85.00	87.00	172.00
<b>Project Totals</b>	<b>86 Parcels</b>	<b>\$5,933.00</b>	<b>\$7,812.60</b>	<b>\$13,745.60</b>







# CONSENT AGENDA ITEM 303

CITY COMMISSION REVISED AGENDA  
AUGUST 12, 2019 | REGULAR MEETING

## TITLE

Asphalt Street Resurfacing Agreement

## SUMMARY

The Fiscal Year 2018-2019 Asphalt Street Resurfacing Program consists of milling and resurfacing City streets at various locations based on Staff's review of the Paving Master Plan. Streets for resurfacing were selected and ranked based on the following factors:

- Overall ride quality
- Traffic Volume
- Pavement Age
- Signs of pavement deterioration and/or structural failure
- Completion of multi-phase paving programs in specific neighborhoods or on specific streets
- Input from Staff and Residents
- Funding availability

This year's paving program consists of the streets listed in the Winter Springs Project Agreement, Exhibit A. The list is subject to change depending on project conditions. The Middlesex Corporation entered into an Agreement with Seminole County of Pavement Management Program Services (#IFM-602096-14/BJC) in December 2014. This contract has been renewed through December 1, 2019 (Exhibit B). The City's purchase order with Middlesex will piggyback off of the unit prices in the Seminole County Agreement, and the work will be performed under an Agreement (Exhibit A) between Middlesex and the City. All unit prices for the major work items in the City's resurfacing project are at or below the corresponding unit prices in the Seminole County Agreement. Staff has also reviewed recent asphalt bids for similar projects in the area and determined that the unit prices in Middlesex's Seminole County Agreement are consistent with current market prices for asphalt milling and resurfacing. Middlesex has successfully completed many asphalt resurfacing projects for the City since 2008.

Middlesex is scheduled to start work in August 2019 with completion by the end of September 2019.

### **Fiscal Impact:**

The project cost is \$566,087.40 plus a 10% contingency, for a total authorization of \$622,696.14, funded by a combination of the Infrastructure Surtax Fund (One-Cent Sales Tax - 3rd Generation) and Transportation Improvement Fund (Local Option Gas Tax) using already budgeted capital improvement dollars.

## **RECOMMENDATION**

Staff recommends the City Commission approve the issuance of a purchase order to The Middlesex Corporation for Asphalt Resurfacing of City Streets in the amount of \$566,087.40 plus a 10% contingency, for a total authorization of \$622,696.14 and authorize the City Manager and City Attorney to prepare and execute any all applicable documents.



## **Project Manual**

### **City of Winter Springs**

#### **Asphalt Resurfacing of City Streets**

**July 2019**

**INDEX TO PROJECT MANUAL**

City of Winter Springs

Asphalt Resurfacing of City Streets

August 2019

DIVISION 0 – BIDDING REQUIREMENTS, CONTRACT FORMS, AND CONDITIONS OF THE CONTRACT

SECTION 00300 – BID FORM ..... 3

SECTION 00500 – AGREEMENT FORM ..... 8

SECTION 00610 – PERFORMANCE BOND FORM ..... 18

SECTION 00620 - LABOR AND MATERIALS PAYMENT BOND ..... 23

SECTION 00660 – NOTICE OF AWARD FORM..... 26

SECTION 00661 – NOTICE TO PROCEED ..... 27

SECTION 00662 – CONTRACTOR’S RELEASE OF LIEN ..... 28

SECTION 00663 – FORM OF CONTRACTOR’S PARTIAL RELEASE OF LIEN ..... 30

SECTION 00680 – APPLICATION FOR PAYMENT ..... 31

SECTION 00700 – GENERAL CONDITIONS ..... 33

**SECTION 00300 – BID FORM**

**1. GENERAL**

**1.1 Description**

The following Bid is hereby made to the City of Winter Springs, hereafter called the OWNER. Bid is submitted by:

Legal Name (indicate whether Sole Proprietorship, Partnership, or Corporation):

---

Address:

---

Contact Name:

---

Contact Phone Number:

---

Contact E-Mail Address:

---

**1.2 The Undersigned:**

**1.2.1 Acknowledges receipt of:**

1.2.1.1 Project Manual for Asphalt Resurfacing of City Streets

1.2.1.2 Addenda:

Number: \_\_\_\_\_, Dated: \_\_\_\_\_

Number: \_\_\_\_\_, Dated: \_\_\_\_\_

**1.2.2** Has examined the site and all Bidding documents and understands that in submitting his Bid, he waives all right to plead any misunderstanding regarding the same.

**1.2.3 Agrees:**

1.2.3.1 To hold this Bid open for **60** calendar days after the bid opening date.

1.2.3.2 To enter into and execute a contract with the OWNER, if awarded on the basis of this Bid.

1.2.3.3 To accomplish the work in accordance with the contract documents.

1.2.3.4 To complete all work within **60** calendar days of the date of the Notice to Proceed (Final Completion)

**1.3 Stipulated Amount**

**1.3.1 Base Bid**

I will provide the services under this project for a Total Base Bid Amount of :

\_\_\_\_\_ Dollars

(\$\_\_\_\_\_)

The Bidder hereby agrees to perform all work as required by the Contract Documents for the following Unit Prices. All work required to be performed by the Contract Documents is to be included within the following Pay Items, inclusive of furnishing all manpower, equipment, materials and performance of all operations relative to construction of the project. Work for which there is not a Pay Item will be considered incidental to the Contract and no additional compensation will be allowed. The OWNER, at his sole option and discretion, may choose to add or deduct from the contract work at the unit prices set forth below. The Bidder shall be paid for actual quantities completed in accordance with the Contract Documents. The following is the order of precedence which will be used in case of conflicts within the Bid Schedule provided by each Bidder: Unit Price, Total Price, Total Base Bid (See attached Bid Form).

**1.4 Bid Schedule**

**1.4.1** Proposals (Bids) must be submitted in triplicate on the Bid Form.

**1.4.2** I have attached a list of all SUBCONTRACTORS I will utilize for the Contract work.

**1.5 Submittal**

RESPECTFULLY SUBMITTED, signed and sealed this \_\_\_\_\_ day of \_\_\_\_\_, 2019

**Bidder**

By: \_\_\_\_\_

Title: \_\_\_\_\_

ATTEST: SECRETARY

SEAL



**ASPHALT RESURFACING OF VARIOUS CITY STREETS  
PRICING FORM**

ITEM NUMBER	DESCRIPTION	UNIT	QUANTITY	UNIT PRICE	TOTAL
1	MOBILIZATION	LS	1		
2	MAINTENANCE OF TRAFFIC	LS	1		
3	EROSION PROTECTION	LS	1		
4	MILLING OF EXISTING ASPHALT (1.75" AVG DEPTH)	SY	51,783		
5	SUPERPAVE ASPHALTIC CONCRETE SP-12.5 (TRAFFIC C)	TN	4,279		
6	<del>Moss</del> <sup>Torcaso</sup> PARK PARKING LOT	LS	1		
TOTAL PRICE (SUM OF ITEMS #1 THROUGH #6):					
<b>PAY ITEM NOTES:</b>					
2	Includes the cost of all items needed for traffic control, (barricades, flagmen, temporary variable message signs, etc.) in accordance with FDOT standards				
4	The milling depth is an average of 1.75". Some streets will require a milling depth greater than 1.75" in order to maintain a finished asphalt edge from 0" to a maximum of 1/4" above gutters and driveways. The thickness of new asphalt is 1.5" unless noted otherwise.				
5	Quantity based on 110 lbs per square yard per 1-inch lift				
5	Unit price includes all equipment, labor, and materials including bituminous material (plant mixes, prime coats, and tack coats) and all other incidental costs to complete the work.				
6	The lump sum item for the <del>Moss</del> <sup>Torcaso</sup> Park Parking Lot includes all preparation costs. The estimated square yardage for the mill and resurface area is 1300 SY. This is to meet the tolerances listed in Item 4. Approximately 250 SY will be asphalt over rolled millings. The lump sum item includes mobilization, maintenance of traffic, re-grading, compaction, rolling of asphalt millings and asphalt. Any miscellaneous work required to complete this line item, including but not limited to installation, restoration, and cleanup, should be included within the lump sum price. The asphalt and milling quantity of this lump sum item is to be included within Bid Item #6.				

PROJECT		PROJECT TYPE	TOTAL YARDS	STRUCTURAL COURSE TONS (110 LB/SY/IN)
<b>FY 2018-2019</b>				
1	Winter Springs Boulevard [Tuskawilla to Benchwood]	RESURFACE	3212	265
2	Trotwood Boulevard [Tuskawilla to Endeavor]	RESURFACE	990	82
3	Bennet Street	RESURFACE	2444.2	202
4	Partridge Circle	RESURFACE	5387.8	445
5	Tarpon Circle	RESURFACE	4665.1	385
6	Shadowbrook Trail	RESURFACE	4694.8	388
7	Papaya Lane and Cottontail Court	RESURFACE	8952.9	739
8	Night Owl Lane and Night Owl Court	RESURFACE	4803.7	397
9	S. Cortez Avenue [Lombardy to Alderwood]	RESURFACE	1967.9	163
10	Evergreen Avenue and Gumtree Court	RESURFACE	4182.2	346
11	N. 2nd Street	RESURFACE	1716	142
12	Charles Street	RESURFACE	2114.2	175
13	Sleeping Rock Court	RESURFACE	2128.5	176
14	White Dove Drive	RESURFACE	4523.2	374
<b>TOTAL</b>			<b>51783</b>	<b>4279</b>







## SECTION 00500 – AGREEMENT FORM

**THIS AGREEMENT MADE THIS \_\_\_\_\_ DAY OF \_\_\_\_\_, 2019** between the CITY OF WINTER SPRINGS, a Florida municipal corporation (herein referred to as OWNER) and \_\_\_\_\_, a \_\_\_\_\_ corporation authorized and duly licensed to do business in the State of Florida (herein referred to as CONTRACTOR), as follows:

1. **DESCRIPTION OF WORK** – CONTRACTOR shall perform the work in accordance with the Contract Documents for the construction of Asphalt Resurfacing of City Streets
2. **CONTRACT DOCUMENTS** – The Contract Documents consist of this Agreement; the Project Manual including all Technical, General and Supplementary Conditions; all Addenda issued prior to and all Change Orders issued after execution of this Agreement; and Contractor’s Bid Submittal. These form the Contract Documents and are incorporated into this Contract by this reference.
3. **ORDER OF PRECEDENCE** - In case of any inconsistency in any of the documents bearing on the Agreement between the OWNER and the CONTRACTOR, the inconsistency shall be resolved by giving precedence in the following order:
  - a. Agreement and Addenda
  - b. CONTRACTOR’s Bid Submittal
  - c. Change Orders
  - d. Special Conditions
  - e. General Conditions

Any inconsistency in the work description shall be clarified by the OWNER and performed by the CONTRACTOR.

4. **AGREEMENT INTERPRETATION** - At its discretion, during the course of the work, should any errors, ambiguities, or discrepancies be found in the Agreement or specifications, the OWNER at its sole discretion will interpret the intent of the Agreement and work descriptions and the CONTRACTOR hereby agrees to abide by the OWNER’s interpretation and agrees to carry out the work in accordance with the decision of the OWNER. When the material, article, or equipment is designated by a brand name and more than one brand name is listed, it will be understood that the work is based on one brand name only. The CONTRACTOR will be responsible for all coordination necessary to accommodate the material, article, or equipment being provided without additional cost to the OWNER. A substitute material, article, or equipment is allowed if it is reasonably equivalent to the brand name specified. The OWNER has full discretion to decide whether a substitute is reasonably equivalent. CONTRACTOR must notify the OWNER prior to use of the substitute for a specified brand name and allow the OWNER to make a determination before CONTRACTOR uses the substitute.
5. **CONTRACT TIME** - The CONTRACTOR shall begin work within **10** days after the issuance of a written Notice to Proceed and the Final Completion of all work shall be within **60** calendar days from the date of the Notice to Proceed. Extensions, if any, are authorized by OWNER, and may only be granted in writing.

6. **LIQUIDATED DAMAGES** - OWNER and CONTRACTOR recognize that time is of the essence of this Agreement and that OWNER will suffer financial loss if the Work is not substantially complete within the time specified in Paragraph 5 above, plus any extensions thereof allowed in accordance with the General Conditions. They also recognize the delays, expense, and difficulties involved in proving in a legal or arbitration proceeding the actual loss suffered by OWNER if the Work is not substantially complete on time. Accordingly, instead of requiring any such proof, OWNER and CONTRACTOR agree that as liquidated damages for delay (but not as a penalty) CONTRACTOR shall pay OWNER **\$200.00** for each day that expires after the time specified in Paragraph 5 for final completion until the work is finally complete, and that OWNER has paid to CONTRACTOR the consideration of Ten (\$10.00) Dollars as consideration for this provision.
  
7. **CONTRACT PRICE, UNIT PRICE CONTRACT** - The OWNER will pay the CONTRACTOR in current funds for the performance of the work, subject to additions and deductions by Change Order, the Total Contract Price of \_\_\_\_\_. Payments will be made to the CONTRACTOR for actual quantities installed on the basis of the Schedule of Unit Prices included as a part of the Bid, which shall be as fully a part of the Contract as if attached or repeated herein.
  
8. **TERMINATION; DEFAULT BY CONTRACTOR AND OWNER'S REMEDIES** - The OWNER reserves the right to revoke and terminate this Agreement and rescind all rights and privileges associated with this Agreement, without penalty, for convenience. Further, the OWNER reserves the right to revoke and terminate this Agreement in the following circumstances, each of which shall represent a default and breach of this Agreement:
  - a. CONTRACTOR defaults in the performance of any material covenant or condition of this Agreement and does not cure such other default within seven (7) calendar days after written notice from the OWNER specifying the default complained of, unless, however, the nature of the default is such that it cannot, in the exercise of reasonable diligence, be remedied within seven (7) calendar days, in which case the CONTRACTOR shall have such time as is reasonably necessary to remedy the default, provided the CONTRACTOR promptly takes and diligently pursues such actions as are necessary therefore; or
  - b. CONTRACTOR is adjudicated bankrupt or makes any assignment for the benefit of creditors or CONTRACTOR becomes insolvent, or is unable or unwilling to pay its debts; or
  - c. CONTRACTOR has acted negligently, as defined by general and applicable law, in performing the Work hereunder; or
  - d. CONTRACTOR has committed any act of fraud upon the OWNER; or
  - e. CONTRACTOR has made a material misrepresentation of fact to the OWNER while performing its obligations under this Agreement; or
  - f. CONTRACTOR is experiencing a labor dispute, which threatens to have a substantial, adverse impact upon performance of this Agreement without prejudice to any other right, or remedy OWNER may have under this Agreement.

Notwithstanding the aforementioned, in the event of a default by CONTRACTOR, the OWNER shall have the right to exercise any other remedy the OWNER may have by operation of law, without limitation, and without any further demand or notice. In the event of such termination, OWNER shall be liable only for the payment of all unpaid charges, determined in accordance with the provisions of this Agreement, for Work properly performed prior to the effective date of termination.

9. **FORCE MAJEURE** - Any delay or failure of either party in the performance of its required obligations hereunder shall be excused if and to the extent caused by acts of God; fire; flood; windstorm; explosion; riot; war; sabotage; strikes (except involving CONTRACTOR's labor force); extraordinary breakdown of or damage to OWNER 's affiliates' generating plants, their equipment, or facilities; court injunction or order; federal and/or state law or regulation; order by any regulatory agency; or cause or causes beyond the reasonable control of the party affected; provided that prompt notice of such delay is given by such party to the other and each of the parties hereunto shall be diligent in attempting to remove such cause or causes. If any circumstance of Force Majeure remains in effect for sixty days, either party may terminate this Agreement.
10. **SEVERABILITY** - In the event any portion or part thereof of this Agreement is deemed invalid, against public policy, void, or otherwise unenforceable by a court of law, the parties, at the sole discretion and option of the OWNER, shall negotiate an equitable adjustment in the affected provision of this Agreement. The validity and enforceability of the remaining parts of this Agreement shall otherwise be fully enforceable.
11. **PROGRESS PAYMENTS** - OWNER shall make progress payments on account of the contract price to CONTRACTOR, on the basis of application for payments submitted to the OWNER or OWNER's Project Manager, by CONTRACTOR as the work progresses, and in accordance with the Contract Documents.

Progress payments may be withheld if:

- a. Work is found defective and not remedied;
  - b. CONTRACTOR does not make prompt and proper payments to SUBCONTRACTORS;
  - c. CONTRACTOR does not make prompt and proper payments for labor, materials, or equipment furnished him;
  - d. Another CONTRACTOR is damaged by an act for which CONTRACTOR is responsible;
  - e. Claims of liens are filed on the job; or
  - f. In the opinion of the City of Winter Springs, CONTRACTOR's work is not progressing satisfactorily
12. **FINAL PAYMENT** - OWNER shall withhold up to 10% of the Contract Price until 50% completion. After 50% completion, OWNER shall reduce to 5% the amount of retainage withheld from each subsequent progress payment made to the CONTRACTOR. For purposes of this section, the term "50-percent completion" shall be the point at which the OWNER has expended 50% of the total cost of the construction services purchased as identified in the Agreement together with all costs associated with existing change orders and other additions or modifications to the Agreement. After 50% completion, the CONTRACTOR may present to the OWNER a payment request for up to one-half of the retainage held by the OWNER. OWNER shall promptly make payment to the CONTRACTOR, unless OWNER has grounds for withholding the payment of retainage.



OWNER shall make final payment to CONTRACTOR within thirty (30) days after the work is fully and properly completed, if the contract has been fully and timely performed, but subject to the condition that final payment shall not be due until CONTRACTOR has delivered to OWNER a complete release of liens arising out the contract, or receipt releases of lien fully covering all labor, materials and equipment for which a lien could be filed, or in the alternative a bond satisfactory to OWNER indemnifying him against such claims.

By making payments OWNER does not waive claims including but not limited to those relating to:

- a. Faulty work appearing after substantial completion has been granted;
- b. Work that does not comply with the Contract Documents;
- c. Outstanding claims of liens; or
- d. Failure of CONTRACTOR to comply with any special guarantees required by the Contract Documents

13. **DESIGNATION OF PROJECT MANAGER OR ARCHITECT OR LANDSCAPE ARCHITECT: DUTIES AND AUTHORITY** - The duties and authority of the OWNER are as follows:

- a. **General Administration of Contract.** The primary function of the OWNER is to provide the general administration of the contract. In performance of these duties, Bryant Smith, P.E., or his authorized representative is the OWNER's Project Manager during the entire period of construction. The OWNER may change the Project Manager during the term of this contract.
- b. **Inspections, Opinions, and Progress Reports.** The OWNER shall be kept familiar with the progress and quality of the work by CONTRACTOR and may make periodic visits to the work site. The OWNER will not be responsible for the means of construction, or for the sequences, methods, and procedures used therein, or for the CONTRACTOR's failure to perform the work in accordance with the Contract Documents.
- c. **Access to Worksite for Inspections.** The OWNER shall be given free access to the worksite at all times during work preparation and progress. The Project Manager is not obligated to make exhaustive or continuous on site inspections to perform his duties of checking and reporting on work progress, and any such inspections shall not waive OWNER's claim regarding defective work by CONTRACTOR.
- d. **Interpretation of Contract Documents; Decisions on Disputes.** The OWNER will be the initial interpreter of the contract document requirements, and make decisions on claims and disputes between CONTRACTOR and OWNER.
- e. **Rejection and Stoppage of Work.** The OWNER shall have authority to reject work which in its opinion does not conform to the Contract Documents, and in this connection may stop the work or a portion thereof, when necessary.
- f. **Payment Certificates.** The OWNER will determine the amounts owing to CONTRACTOR as the work progresses, based on CONTRACTOR's applications and OWNER's inspections and observations, and will issue certificates for progress payments and final payments in accordance with the terms of the Contract Documents.

14. **PROGRESS MEETING** – OWNER’s Project Manager may hold periodic progress meetings on a monthly basis, or more frequently if required by the OWNER, during the term of work entered into under this Agreement. CONTRACTOR’s Project Manager and all other appropriate personnel shall attend such meetings as designated by the OWNER’s Project Manager.
15. **RESPONSIBILITIES OF CONTRACTOR** – CONTRACTOR’s duties and rights in connection with the project herein are as follows:
- a. **Responsibility for Supervision and Construction.** CONTRACTOR shall be solely responsible for all construction under this contract, including the techniques, sequences, procedures and means, for the coordination of all work. CONTRACTOR shall supervise and direct the work, and give it all attention necessary for such proper supervision and direction.
  - b. **Discipline and Employment.** CONTRACTOR shall maintain at all times strict discipline among his employees, and he agrees not to employ for work on the project any person unfit or without sufficient skill to perform the job for which he has employed.
  - c. **Furnishing of Labor, Materials, etc.** CONTRACTOR shall provide and pay for all labor, materials and equipment, including tools, construction equipment and machinery, utilities, including water, transportation, and all other facilities and work necessary for the proper completion of work on the project in accordance with the Contract Documents
  - d. **Payment of Taxes: Procurement of Licenses and Permits.** CONTRACTOR shall secure all licenses and permits necessary for proper completion of the work, paying the fees thereof. CONTRACTOR warrants that it (and SUBCONTRACTORS or tradesmen, if authorized in the Contract Documents) hold or will secure all trade or professional licenses required by law for CONTRACTOR to undertake the contract work.
  - e. CONTRACTOR will provide written guarantee for work and materials for two (2) calendar years after acceptance by OWNER.
16. **ASSIGNMENT** – CONTRACTOR shall not assign or subcontract this Agreement, or any rights or any monies due or to become due hereunder without the prior, written consent of the OWNER.
- a. If upon receiving written approval from OWNER, any part of this Agreement is subcontracted by CONTRACTOR, CONTRACTOR shall be fully responsible to OWNER for all acts and/or omissions performed by the subcontractor as if no subcontract had been made.
  - b. If OWNER determines that any subcontractor is not performing in accordance with this Agreement, OWNER shall so notify CONTRACTOR who shall take immediate steps to remedy the situation.
  - c. If CONTRACTOR, prior to the commencement of any work subcontracts any part of this Agreement by the subcontractor, CONTRACTOR shall require the subcontractor to provide OWNER and its affiliates with insurance coverage as set forth by the OWNER.

17. **THIRD PARTY RIGHTS** – Nothing in this Agreement shall be construed to give any rights or benefits to anyone other than OWNER and CONTRACTOR.
18. **PROHIBITION AGAINST CONTINGENT FEES** – CONTRACTOR warrants that it has not employed or retained any company or person, other than a bona fide employee working solely for the CONTRACTOR, to solicit or secure this Agreement, and that it has not paid or agreed to pay any person, company, corporation, individual, or firm, other than a bona fide employee working solely for the CONTRACTOR, any fee, commission, percentage, gift, or other consideration contingent upon or resulting from the award or making of this Agreement.
19. **NO JOINT VENTURE** – Nothing herein shall be deemed to create a joint venture or principal-agent relationship between the parties and neither party is authorized to, nor shall either party act toward third party persons or the public in any manner which would indicate any such relationship with the other party.
20. **INDEMNIFICATION** – CONTRACTOR shall indemnify and hold harmless the City, its officers, employees, and city attorneys (individually and in their official capacity, from liability, losses, damages, and costs, including, but not limited to, reasonable attorney’s fees, to the extent caused by the negligence, recklessness or intentional wrongful misconduct of CONTRACTOR and persons employed or utilized by CONTRACTOR in the performance of this Agreement.

The indemnification provided above shall obligate the CONTRACTOR to defend at its own expense or to provide for such defense, at the option of the OWNER, as the case may be, of any and all claims of liability and all suits and actions of every name and description that may be brought against the OWNER or its officers, employees, and city attorneys which may be covered by this indemnification. In all events the OWNER and its officers, employees, and city attorneys shall be permitted to choose legal counsel of its sole choice, the fees for which shall be reasonable and subject to and included with this indemnification provided herein.

21. **SAFETY** – CONTRACTOR shall be solely and absolutely responsible and assume all liability for the safety and supervision of its principals, employees, CONTRACTORS, and agents while performing work provided hereunder.
22. **CORPORATE REPRESENTATIONS BY CONTRACTOR** – CONTRACTOR hereby represents and warrants to the OWNER the following:
  - a. CONTRACTOR is duly registered and licensed to do business in the State of Florida and is in good standing under the laws of Florida, and is duly qualified and authorized to carry on the functions and operations set forth in this Agreement.
  - b. The undersigned signatory for CONTRACTOR has the power, authority, and the legal right to enter into and perform the obligations set forth in this Agreement and all applicable exhibits thereto, and the execution, delivery, and performance hereof by CONTRACTOR has been duly authorized by the board of directors and/or president of CONTRACTOR. In support of said representation, CONTRACTOR agrees to provide a copy to the OWNER of a corporate certificate of good standing provided by the State of Florida prior to the execution of this Agreement.

- c. CONTRACTOR is duly licensed under all local, state and federal laws to provide the work stated in paragraph 1.0 herein. In support of said representation, CONTRACTOR agrees to provide a copy of all said licenses to the OWNER prior to the execution of this Agreement.
23. **BOND** – CONTRACTOR shall supply a materials, performance and payment bond(s) in accordance with Florida law and to the satisfaction of OWNER, in an amount specified in the Contract Documents.
24. **INSURANCE** - During the term of this Agreement, CONTRACTOR shall be responsible for providing the types of insurance and limits of liability as set forth below.
- a. The CONTRACTOR shall maintain comprehensive general liability insurance in the minimum amount of \$2,000,000 as the combined single limit for each occurrence to protect the CONTRACTOR from claims of property damages which may arise from any Work performed under this Agreement whether such Work are performed by the CONTRACTOR or by anyone directly employed by or contracting with the CONTRACTOR.
  - b. The CONTRACTOR shall maintain comprehensive automobile liability insurance in the minimum amount of \$1,000,000 combined single limit bodily injury and minimum \$1,000,000 property damage as the combined single limit for each occurrence to protect the CONTRACTOR from claims for damages for bodily injury, including wrongful death, as well as from claims from property damage, which may arise from the Ownership, use, or maintenance of owned and non-owned automobiles, including rented automobiles whether such operations be by the CONTRACTOR or by anyone directly or indirectly employed by the CONTRACTOR.
  - c. The CONTRACTOR shall maintain, during the life of this Agreement, adequate Workers' Compensation Insurance in at least such amounts as are required by law and Employer's Liability Insurance in the minimum amount of \$2,000,000 for all of its employees performing Work for the OWNER pursuant to this Agreement.

**Special Requirements.** Current, valid insurance policies meeting the requirements herein identified shall be maintained during the term of this Agreement. A copy of a current Certificate of Insurance shall be provided to the OWNER by CONTRACTOR upon the Effective Date of this Contract which satisfied the insurance requirements of this paragraph 24. Renewal certificates shall be sent to the OWNER 30 days prior to any expiration date. There shall also be a 30-day advance written notification to the OWNER in the event of cancellation or modification of any stipulated insurance coverage. **The OWNER shall be an additional named insured on all stipulated insurance policies as its interest may appear, from time to time.**

**Independent Associates and Consultants.** All independent CONTRACTORS or agents employed by CONTRACTOR to perform any Work hereunder shall fully comply with the insurance provisions contained in paragraph 24.

25. **MEDIATION/VENUE** - The parties agree that should any dispute arise between them regarding the terms or performance of this Agreement, both parties will participate in mediation. The parties agree to equally

share the cost of the mediator. Should the parties fail to resolve their differences through mediation, then any cause of action filed hereunder shall be filed in the Circuit or County Court for Seminole County, Florida.

26. **GOVERNING LAW & VENUE** - This Agreement is made and shall be interpreted, construed, governed, and enforced in accordance with the laws of the State of Florida. Venue for any state action or litigation shall be Seminole County, Florida. Venue for any federal action or litigation shall be Orlando, Florida.
27. **ATTORNEY'S FEES** - Should either party bring an action to enforce any of the terms of this Agreement, the prevailing party shall be entitled, to the extent permitted by law, to recover from the non-prevailing party the costs and expenses of such action including, but not limited to, reasonable attorney's fees, whether at settlement, trial or on appeal.
28. **NOTICES** - Any notice or approval under this Contract shall be sent, postage prepaid, to the applicable party at the address shown on the first page of this Contract.
29. **WORK IS A PRIVATE UNDERTAKING** - With regard to any and all Work performed hereunder, it is specifically understood and agreed to by and between the parties hereto that the contractual relationship between the OWNER and CONTRACTOR is such that the CONTRACTOR is an independent CONTRACTOR and not an agent of the OWNER. The CONTRACTOR, its CONTRACTORS, partners, agents, and their employees are independent CONTRACTORS and not employees of the OWNER. Nothing in this Agreement shall be interpreted to establish any relationship other than that of an independent CONTRACTOR, between the OWNER, on one hand, and the CONTRACTOR, its CONTRACTORS, partners, employees, or agents, during or after the performance of the Work under this Agreement.
30. **DOCUMENTS - Public Records**: It is hereby specifically agreed that any record, document, computerized information and program, audio or video tape, photograph, or other writing of the CONTRACTOR and its independent CONTRACTORS and associates related, directly or indirectly, to this Agreement, may be deemed to be a Public Record whether in the possession or control of the OWNER or the CONTRACTOR. Said record, document, computerized information and program, audio or video tape, photograph, or other writing of the CONTRACTOR is subject to the provisions of Chapter 119, Florida Statutes, and may not be destroyed without the specific written approval of the OWNER's City Manager. Upon request by the OWNER, the CONTRACTOR shall promptly supply copies of said public records to the OWNER. All books, cards, registers, receipts, documents, and other papers in connection with this Agreement shall at any and all reasonable times during the normal working hours of the CONTRACTOR be open and freely exhibited to the OWNER for the purpose of examination and/or audit.

The CONTRACTOR acknowledges that the OWNER is a Florida municipal corporation and subject to the Florida Public Records Law. CONTRACTOR agrees that to the extent any document produced by CONTRACTOR under this Agreement constitutes a Public Record; CONTRACTOR shall comply with the Florida Public Records Law.

31. **SOVEREIGN IMMUNITY** - Notwithstanding any other provision set forth in this Agreement, nothing contained in this Agreement shall be construed as a waiver of the CITY'S right to sovereign immunity under

Section 768.28, or other limitations imposed on the CITY'S potential liability under state or federal law. As such, the CITY shall not be liable, under this Agreement for punitive damages or interest for the period before judgment. Further, the CITY shall not be liable for any claim or judgment, or portion thereof, to any one person for more than one hundred thousand dollars (\$100,000.00), or any claim or judgment, or portion thereof, which, when totaled with all other claims or judgments paid by the State or its agencies and subdivisions arising out of the same incident or occurrence, exceeds the sum of two hundred thousand dollars (\$200,000.00).

32. **HEADINGS** - Paragraph headings are for the convenience of the parties only and are not to be construed as part of this Agreement.
33. **INTEGRATION; MODIFICATION** - The drafting, execution, and delivery of this Agreement by the Parties has been induced by no representations, statements, warranties, or agreements other than those expressed herein. This Agreement embodies the entire understanding of the parties, and there are no further or other agreements or understandings, written or oral, in effect between the parties relating to the subject matter hereof unless expressly referred to herein. Modifications of this Agreement shall only be made in writing signed by both parties.
34. **WAIVER AND ELECTION OF REMEDIES** - Waiver by either party of any terms, or provision of this Agreement shall not be considered a waiver of that term, condition, or provision in the future. No waiver, consent, or modification of any of the provisions of this Agreement shall be binding unless in writing and signed by a duly authorized representative of each party hereto. This Agreement may be executed in any number of counterparts, each of which when so executed and delivered shall be considered an original agreement; but such counterparts shall together constitute but one and the same instrument.
35. **DRAFTING** - OWNER and CONTRACTOR each represent that they have both shared equally in drafting this Agreement and no party shall be favored or disfavored regarding the interpretation of this Agreement in the event of a dispute between the parties.
36. **NOTICE** - Any notices required to be given by the terms of this Agreement shall be delivered by hand or mailed, postage prepaid to:

**For CONTRACTOR:**

**For OWNER:**

City of Winter Springs  
City Engineer, Public Works Department  
1126 East State Road 434,  
Winter Springs, FL 32708

Either party may change this notice address by providing the other party written notice of the change.

Signed, Sealed and Delivered in the presence of:

\_\_\_\_\_  
Witness

\_\_\_\_\_  
Witness

\_\_\_\_\_  
Witness

\_\_\_\_\_  
Witness

CONTRACTOR:

\_\_\_\_\_  
Name

\_\_\_\_\_  
Title

\_\_\_\_\_  
Business Address

\_\_\_\_\_  
City, State Zip

\_\_\_\_\_  
Date

OWNER:  
CITY OF WINTER SPRINGS

\_\_\_\_\_  
By: Shawn Boyle  
Interim City Manager

1126 East State Road 434  
Winter Springs, FL 32708  
407-327-1800



**SECTION 00610 – PERFORMANCE BOND FORM**

Bond No. \_\_\_\_\_

**BY THIS PERFORMANCE BOND**, We \_\_\_\_\_, as Principal, whose address is \_\_\_\_\_ and telephone number is \_\_\_\_\_ and \_\_\_\_\_, as Surety, whose address is \_\_\_\_\_ and telephone number is \_\_\_\_\_ are bound to the City of Winter Springs, a Florida municipal corporation, as OWNER, whose address is 1126 E. State Road 434, Winter Springs, Florida 32708 and telephone number is 407-327-8979, in the initial sum of \$ \_\_\_\_\_ (110% of Contract Price), or such greater amount as the Contract may be adjusted from time to time in accordance with the Contract between the Principal and OWNER) (the "Penal Sum").

**WHEREAS**, the Principal has executed a contract with the OWNER, dated \_\_\_\_\_, for the construction of the \_\_\_\_\_ project in the City of Winter Springs, Seminole County, Florida (the "Project"); and

**WHEREAS**, the OWNER has required the Principal to furnish a performance bond in accordance with law and as a condition of executing the Contract with Principal; and

**WHEREAS**, this bond is being entered into to satisfy the requirements of Section 255.05(1), Florida Statutes and the Contract referenced above, as the same may be amended, and additionally, to provide common law rights more expansive than as required by statute.

**NOW THEREFORE**, the Surety and the Principal, both joint and severally, and for themselves, their heirs, administrators, executors, successors and assigns agree as follows:

1. **CONTRACT INCORPORATED; SURETY AND PRINCIPAL BOUND FOR FULL PERFORMANCE.** The Contract is incorporated by reference and made a part of this bond. The Surety and the Principal are bound for the full performance of the Contract including without exception all of the Contract Documents (as defined in the Contract) and all of their terms and conditions, both express and implied. Without limiting the Principal's and Surety's obligations under the Contract and this bond, the Principal and Surety agree:
  - 1.1 Promptly and faithfully perform their duties and all the covenants, terms, conditions, and obligations under the Contract including, but not limited to the insurance provisions, guaranty period and the warranty provisions, in the time and manner prescribed in the Agreement, and
  - 1.2 Pay OWNER all losses, damages, delay damages (liquidated or actual), expenses, costs and attorneys' fees, including costs and attorney's fees on appeal that OWNER sustains resulting directly or indirectly from any breach or default by Principal under the Contract, and

1.3 Satisfy all claims and demands incurred under the Contract, and fully indemnify and hold harmless the OWNER from all costs and damages which it may suffer by reason or failure to do so.

2. **OWNER'S AFFIDAVIT OF CONTRACTOR BREACH OR DEFAULT.** If the OWNER shall provide to Surety the written affidavit of the OWNER stating that the Principal is in breach or default of the Contract, and that such breach or default remains uncured by the Principal, then upon delivery of such affidavit to the Surety in the method for providing notices as set forth in Paragraph 7 below, Surety must promptly notify the OWNER in writing which action it will take as permitted in Paragraph 3.

3. **SURETY'S OBLIGATION UPON DELIVERY OF OWNER'S AFFIDAVIT OF CONTRACTOR'S BREACH OR DEFAULT.** Upon the delivery of the OWNER's affidavit of breach or default by the Principal as provided in Paragraph 2 above, the Surety may promptly remedy the breach or default or must, within ten (10) days, proceed to take one of the following courses of action:

3.1 **Proceed Itself.** Complete performance of the Contract including correction of defective and nonconforming Work through its own CONTRACTORS or employees, approved as being acceptable to the OWNER, in the OWNER's sole discretion, provided, however, that OWNER's discretion in approving the Surety's CONTRACTOR will not be unreasonably withheld as to any CONTRACTOR who would have qualified to offer a proposal on the Contract and is not affiliated in any way with the Principal. During this performance by the Surety, the OWNER will pay the Surety from its own funds only those sums as would have been due and payable to the Principal under the Contract as and when they would have been due and payable to the Principal in the absence of the breach or default not to exceed the amount of the remaining Contract balance less any sums due the OWNER under the Contract. During this performance by Surety, any payment bond required under the Contract must remain in full force and effect; or

3.2 **Tender a completing CONTRACTOR acceptable to OWNER.** Tender a CONTRACTOR, together with a contact for fulfillment and completion of the Contract executed by the completing CONTRACTOR, to the OWNER for the OWNER's execution. OWNER's discretion to approve Surety's completing CONTRACTOR will not be unreasonably withheld as to any CONTRACTOR who would have qualified to offer a proposal on the contract and is not affiliated with the Principal. OWNER's discretion to approve the CONTRACTOR as the completing CONTRACTOR and to approve the tendered contract shall be in OWNER's sole and absolute discretion. Upon execution by the OWNER of the contract for fulfillment and completion of the Contract, the completing CONTRACTOR must furnish to the OWNER a performance bond and a separate payment bond, each in the form of those bonds previously furnished to the OWNER for the Project by the Principal. Each such bond must be in the Penal Sum of the full cost to complete the Contract. The OWNER will pay the completing CONTRACTOR from its own funds only those sums as would have been due and payable to the Principal under the Contract as and when they would have been due and payable to the Principal in the absence of the breach or default not to exceed the amount of the remaining Contract balance less any sums due the OWNER under the Contract. To the extent that the OWNER is obligated to pay the completing CONTRACTOR sums which would not have been due and payable to the CONTRACTOR under the Contract (any sums in excess of the then remaining Contract balance less any sums due the OWNER under the Contract), the Surety must pay the OWNER the full amount of

those sums at the time the completing CONTRACTOR tenders an invoice to the OWNER so that the OWNER can utilize those sums in making timely payment to the completing CONTRACTOR; or

3.3 **Tender the Full Penal Sum.** Tender to the OWNER the full Penal Sum of the performance bond. The OWNER will refund to the Surety without interest any unused portion not spent by the OWNER procuring and paying a completing CONTRACTOR or completing the Contract itself, plus the cost allowed under Section 4, after completion of the contract for fulfillment and completion of the Contract and the expiration of any applicable warranties; or

3.4 **Other Acts.** Take any other acts mutually agreed upon in writing by the OWNER and the Surety.

3.5 **IT SHALL BE NO DEFENSE TO SURETY'S OBLIGATION TO UNDERTAKE ONE OF THE PRECEDING COURSES OF ACTION THAT THE PRINCIPAL CONTENDS THAT IT IS NOT IN BREACH OR DEFAULT OF THE CONTRACT, OR THAT THE NOTICE OF BREACH OR DEFAULT WAS DEFECTIVE, OR THAT THE PRINCIPAL HAS RAISED ANY OTHER CLAIM OF DEFENSE OR OFFSET, PROVIDED ONLY THAT THE SURETY HAS RECEIVED THE AFFIDAVIT OF THE OWNER AS SPECIFIED IN PARAGRAPH 2.**

4. **SURETY'S ADDITIONAL OBLIGATIONS.** In addition to those duties set forth herein above, the Surety must promptly pay the OWNER (i) all losses, costs and expenses resulting from the Principal's breach(es) or default(s), including, without limitation, fees (including attorney's fees and related costs), expenses and costs for architects, engineers, consultants, testing, surveying and attorneys, plus (ii) liquidated or actual damages, whichever may be provided for in the Contract, for lost use of the Project, plus (iii) reprocurement costs and fees and expenses, plus (iv) costs incurred at the direction, request, or as a result of the acts or omissions of the Surety; provided that in no event shall Surety's liability exceed the Penal Sum of this Bond.

5. **SURETY'S WAIVER OF NOTICE.** The Surety waives notice of any Modifications to the Contract, including changes in the Contract Time, the Contract Sum, the amount of liquidated damages, or the work to be performed under the Contract.

6. **NO THIRD PARTY BENEFICIARIES.** The Surety provides this performance bond for the sole and exclusive benefit of the OWNER and OWNER's heirs, administrators, executors, successors and assigns. No other party, person or entity has any rights against the Surety.

7. **METHOD OF NOTICE.** All notices to the Surety, the Principal or the OWNER must be given by Certified Mail, Return Receipt Requested, to the address set fourth for each party below.

**SURETY:**

Name: \_\_\_\_\_  
Attention: \_\_\_\_\_  
Street: \_\_\_\_\_  
City, State: \_\_\_\_\_  
Zip: \_\_\_\_\_

**PRINCIPAL:**

Name: \_\_\_\_\_  
Attention: \_\_\_\_\_  
Street: \_\_\_\_\_  
City, State: \_\_\_\_\_  
Zip: \_\_\_\_\_

**OWNER:**

The City of Winter Springs  
Attention: Shawn Boyle  
1126 E. State Road 434  
Winter Springs, Florida 32708  
(407) 327-1800

**With a copy to:**

Anthony A. Garganese, Weiss & D'Agresta, P.A.  
111 N. Orange Avenue, Suite 2000  
Orlando, Florida 32802  
(407) 425-9566

8. **STATUE OF LIMITATIONS.** Any statutory limitation, which may be contractually superseded, to the contrary notwithstanding, any action hereon may be instituted so long as the applicable statute of limitations governing the Contract (including any warranty period) has not run or expired or within three (3) years following Final Completion of the Contract (including any warranty period) and acceptance of the Work performed under the Contract by the OWNER, whichever is longer.
9. **RECITALS.** The recitals contained in this Performance Bond are incorporated by reference herein and are expressly made a part of this Performance Bond.
10. **GOVERNING LAW.** This performance bond shall be governed by, and construed in accordance with the laws of the State of Florida without regard to its conflict of law's provisions.
11. **VENUE.** In the event any legal action shall be filed upon this performance bond, venue shall lie exclusively in the Circuit Court for Seminole County, Florida.
12. **MISCELLANEOUS.**
  - 12.1 The Surety agrees that this performance bond shall afford the OWNER with all of the protections and rights afforded under Florida Statutes and under common law.
  - 12.2 This performance bond is issued in addition to any other bond or warranty required under the Contract including, but not limited to, any labor and materials payment bond and maintenance bond. Each bond issued under the Contract shall be construed as separate and distinct from each other.

12.3 In the event that the Surety fails to fulfill its obligations under this performance bond, then the Surety shall also indemnify and hold the OWNER harmless from any and all loss, damage, cost and expense, including reasonable attorneys' fees and costs for all trial and appellate proceedings, resulting directly or indirectly from the Surety's failure to fulfill its obligations hereunder. This subsection shall survive the termination or cancellation of this performance bond.

12.4 This performance bond shall remain in full force and effect until such time all the work, labor and materials under the Contract have been performed or provided to the OWNER's complete satisfaction, through the expiration of all warranty periods.

**Principal**

**Surety**

\_\_\_\_\_  
(Typed Firm Name)

\_\_\_\_\_  
(Typed Firm Name)

\_\_\_\_\_  
(Seal)

\_\_\_\_\_  
(Seal)

By: \_\_\_\_\_

By: \_\_\_\_\_

\_\_\_\_\_  
(Signature)

\_\_\_\_\_  
(Signature)

\_\_\_\_\_  
(Printer Name)

\_\_\_\_\_  
(Printed Name)

\_\_\_\_\_  
(Title)

\_\_\_\_\_  
(Title)

\_\_\_\_\_  
(Address)

\_\_\_\_\_  
(Address)

\_\_\_\_\_  
(Date of Execution)

\_\_\_\_\_  
(Date of Execution)

**SECTION 00620 - LABOR AND MATERIALS PAYMENT BOND**

Bond No. \_\_\_\_\_

**BY THIS LABOR AND MATERIALS PAYMENT BOND**, We \_\_\_\_\_, as Principal, whose address is \_\_\_\_\_ and telephone number is \_\_\_\_\_ and \_\_\_\_\_, as Surety, whose address is \_\_\_\_\_ and telephone number is \_\_\_\_\_ are bound to the City of Winter Springs, a Florida municipal corporation, as Owner, whose address is 1126 E. State Road 434, Winter Springs, Florida 32708 and telephone number is 407-327-1800, in the initial sum of \$ \_\_\_\_\_ (110% of Contract Price), or such greater amount as the Contract may be adjusted from time to time in accordance with the Contract between the Principal and Owner) (the "Penal Sum").

**WHEREAS**, the Principal has executed a contract with the Owner, dated \_\_\_\_\_, Contract No. \_\_\_\_\_ (the "Contract") for the construction of the \_\_\_\_\_ project in the City of Winter Springs, Seminole County, Florida (the "Project"); and

**WHEREAS**, the Owner has required the Principal to furnish a labor and materials payment bond in accordance with law and as a condition of executing the Contract with Principal; and

**WHEREAS**, this bond is being entered into to satisfy the requirements of Section 255.05(1), Florida Statutes and the Contract referenced above, as the same may be amended, and additionally, to provide common law rights more expansive than as required by statute.

**NOW THEREFORE**, the Surety and the Principal, both joint and severally, and for themselves, their heirs, administrators, executors, successors and assigns agree as follows:

- 1. CONTRACT INCORPORATED; SURETY AND PRINCIPAL BOUND FOR FULL PERFORMANCE.** The Contract is incorporated by reference and made a part of this bond. The Surety and the Principal are bound to promptly make payments to all claimants, as defined in Section 255.05(1), Florida Statutes, supplying Principal with labor, materials, supplies, or rental equipment used directly or indirectly by Principal in the prosecution of the work provided under the Contract. Any such payments shall not involve the Owner in any expense.
- 2. CLAIMS.** Claims made under this bond shall be made pursuant to provisions of Section 255.05, Florida Statutes, and applicable law. Therefore, a claimant, except a laborer, who is not in privity with the Principal shall, before commencing or not later than 45 days after commencing to furnish labor, services, or materials for the prosecution of the work, furnish the Principal with written notice that he or she intends to look to

the bond for protection. A claimant who is not in privity with the Principal and who has not received payment for his or her labor, services, or materials shall deliver to the Principal and to the surety written notice of the performance of the labor or delivery of materials or supplies and of the nonpayment. The notice of nonpayment may be served at any time during the progress of the work or thereafter but not before 45 days after the first furnishing of labor, services, or materials, and not later than 90 days after the final furnishing of the labor, services, or materials by the claimant or, with respect to the rental equipment, not later than 90 days after the date that the rental equipment was last on the job site available for use. Any notice of nonpayment served by a claimant who is not in privity with Principal which includes sums for retainage must specify the portion of the amount claimed for retainage.

3. **SURETY'S WAIVER OF NOTICE.** The Surety waives notice of any modifications to the Contract, including changes in the Contract Time, the Contract Sum, or the labor, work, or materials required to be performed under the Contract.
4. **BENEFICIARIES.** The Surety provides this performance bond for the sole and exclusive benefit of the Owner and Owner's heirs, administrators, executors, successors and assigns, as well as for the benefit of any claimants who have actually provided labor, material, rental equipment, or services under the Contract.
5. **RECITALS.** The recitals contained in this labor and materials payment bond are incorporated by reference herein and are expressly made a part of this bond.
6. **GOVERNING LAW.** This labor and materials payment bond shall be governed by, and construed in accordance with the laws of the State of Florida without regard to its conflict of laws provisions.
7. **VENUE.** In the event any legal action shall be filed upon this labor and materials payment bond, venue shall lie exclusively in the Circuit Court for Seminole County, Florida.
8. **MISCELLANEOUS.**
  - A. The Surety agrees that this labor and materials payment bond shall afford the Owner and all claimants under the Contract with all of the protections and rights afforded under Florida Statutes and under common law.
  - B. This labor and materials payment bond is issued in addition to any other bond or warranty required under the Contract including, but not limited to, any performance bond and maintenance bond. Each bond issued under the Contract shall be construed as separate and distinct from each other.
  - C. In the event that the Surety fails to fulfill its obligations under this labor and materials payment bond, then the Surety shall also indemnify and hold the OWNER harmless from any and all loss, damage, cost and expense, including reasonable attorneys' fees and costs for all trial and appellate



proceedings, resulting directly or indirectly from the Surety's failure to fulfill its obligations hereunder. This subsection shall survive the termination or cancellation of this labor and materials payment bond.

- D. This labor and materials payment bond shall remain in full force and effect until such time that the legal deadline for filing a claim hereunder has duly expired.

**Principal**

**Surety**

\_\_\_\_\_  
(Typed Firm Name)

\_\_\_\_\_  
(Typed Firm Name)

\_\_\_\_\_  
(Seal)

\_\_\_\_\_  
(Seal)

By:

By:

\_\_\_\_\_  
(Signature)

\_\_\_\_\_  
(Signature)

\_\_\_\_\_  
(Printed Name)

\_\_\_\_\_  
(Printed Name)

\_\_\_\_\_  
(Title)

\_\_\_\_\_  
(Title)

\_\_\_\_\_  
(Address)

\_\_\_\_\_  
(Address)

\_\_\_\_\_  
(Date of Execution)

\_\_\_\_\_  
(Date of Execution)

END OF SECTION

SECTION 00660 – NOTICE OF AWARD FORM

TO:

PROJECT NAME: Asphalt Resurfacing of City Streets

The OWNER has considered the Bid submitted by \_\_\_\_\_ for the above described work.

You are hereby notified that your bid has been accepted, and the total amount of the contract award is \$\_\_\_\_\_.

You are required by the Instructions to Bidders to execute the Agreement and certificates of insurance within ten (10) calendar days from the date of this Notice to you. If you fail to execute said Agreement and to furnish said certificate of insurance within ten (10) calendar days from the date of this Notice, said OWNER will be entitled to consider all your rights arising out of the OWNER’s acceptance of your BID as abandoned. The OWNER will be entitled to such other rights as may be granted by law.

You are required to return an acknowledged copy of this NOTICE OF AWARD to the OWNER.

Dated this \_\_\_\_ day of \_\_\_\_\_, 2019.

OWNER:

BY: \_\_\_\_\_  
Bryant Smith, P.E.

Title: City Engineer

ACCEPTANCE OF NOTICE

Receipt and acceptance of the above NOTICE OF AWARD is hereby acknowledged by \_\_\_\_\_ this the day of \_\_\_\_\_, 2019.

BY: \_\_\_\_\_

Title: \_\_\_\_\_

**SECTION 00661 – NOTICE TO PROCEED**

**TO:**

**EFFECTIVE DATE OF THE NOTICE TO PROCEED:**

**PROJECT: Asphalt Resurfacing of City Streets**

You are hereby notified to commence work in accordance with the agreement dated \_\_\_\_\_ . In accordance with the Agreement, work shall commence within 10 calendar days of the date of this Notice To Proceed and shall be complete within **60** consecutive calendar dates from the effective date of this Notice To Proceed. The final date of completion of all work is therefore \_\_\_\_\_ .

By: \_\_\_\_\_

Name: Bryant Smith, P.E.  
Title: City Engineer

---

**ACCEPTANCE OF NOTICE**

Receipt and acceptance of the above NOTICE TO PROCEED is hereby acknowledged by \_\_\_\_\_ this the day of \_\_\_\_\_, 2019.

BY: \_\_\_\_\_

Title: \_\_\_\_\_

**SECTION 00662 – CONTRACTOR’S RELEASE OF LIEN**

Before me, the undersigned authority in said County and State, appeared \_\_\_\_\_ who, being first duly sworn, deposes and says that he is \_\_\_\_\_ of, a company and/or corporation authorized to do business under the laws of Florida, which is the Service Provider on a Project located in the City of \_\_\_\_\_, County of \_\_\_\_\_, Florida, with the City of \_\_\_\_\_, dated the \_\_\_\_\_ day of \_\_\_\_\_, 20\_\_\_\_, that the said deponent is duly authorized to make this affidavit by resolution of the Board of Directors of said company and/or corporation; that deponent knows of his own knowledge that said contract has been complied with in every particular by said Service Provider and that all parts of the work have been approved by the OWNER; that there are no bills remaining unpaid for labor, material, or otherwise, in connection with said contract and work, and that there are no suits pending against the undersigned as Service Provider or anyone in connection with the work done and materials furnished or otherwise under said contract. Deponent further says that the final estimate which has been submitted to the OWNER simultaneously with the making of this affidavit constitutes all claims and demands against the OWNER on account of said contract or otherwise, and the acceptance of the sum specified in said final estimate will operate as a full and final release and discharge of the OWNER from any further claims, demands or compensation by the CONTRACTOR under the above contract. Deponent further agrees that all guarantees under this contract shall and be in full force from the date of this release as spelled out in the Contract Documents.

Sworn to and subscribed to before me this \_\_\_\_\_ day of \_\_\_\_\_, 20\_\_\_\_\_.

*Notary Public*

My Commission Expires:

We the \_\_\_\_\_ having heretofore executed a performance bond for the above-named CONTRACTOR covering project and section as described above in the sum of \_\_\_\_\_ dollars (\$\_\_\_\_\_), hereby agree that the OWNER may make full payment of the final estimate, including the retained percentage, to said CONTRACTOR.

It is fully understood that the granting of the right to the OWNER to make payment of the final estimate to said CONTRACTOR and/or his assigns, shall in no way relieve this surety company of its obligations under its bond, as set forth in the specifications, contract and bond pertaining to the above project.

**IN WITNESS WHEREOF**, the \_\_\_\_\_ has caused this instrument to be executed on its behalf by its and/or its duly authorized attorney in fact, and its corporate seal to be hereunto affixed, all on this \_\_\_\_\_ day of \_\_\_\_\_, 20\_\_\_\_ (A.D.).

Surety Company

Attorney in Fact

(Power of Attorney must be attached if executed by Attorney in Fact)

**STATE OF FLORIDA**

**COUNTY OF \_\_\_\_\_**

The foregoing instrument was acknowledged before me this \_\_\_\_\_ (DATE) by \_\_\_\_\_ (NAME OF PERSON) who is personally known to me or has produced \_\_\_\_\_ (TYPE OF IDENTIFICATION) as identification and who did (did not) take an oath.

**Signature of Person Taking Acknowledgment**

Name: \_\_\_\_\_  
(Typed, Printed, or Stamped)

Title: \_\_\_\_\_

Serial No. : \_\_\_\_\_  
(If any)

**IN WITNESS WHEREOF**, I have hereunto set my hand and official seal at \_\_\_\_\_ this \_\_\_\_\_ day of \_\_\_\_\_, 20\_\_\_\_.

**SECTION 00663 – FORM OF CONTRACTOR’S PARTIAL RELEASE OF LIEN**

**KNOW ALL MEN BY THESE PRESENTS**, that the undersigned, \_\_\_\_\_ in consideration of partial payment in the sum of \$ \_\_\_\_\_, receipt whereof is hereby acknowledged, and other valuable considerations and benefits to the undersigned accruing, do hereby waive, release and quit claim all liens, lien rights, claims or demands of every kind whatsoever which the undersigned now has, or may hereafter have, against that certain real estate and the improvements thereof, situated in , \_\_\_\_\_ County, Florida, and legally described as:

on account of work and labor performed, and/or materials furnished in, to, or about the construction of any building or buildings situated thereon, or in improving said property above described, or any part thereof.

It being the understanding of the undersigned that this is a Partial Waiver and Release of Lien which the undersigned has against the premises described herein, only to the extent of the payments specified and only for materials furnished or work done up until \_\_\_\_\_ (but not releasing or waiving charges for changes, additions, or extras), the undersigned warrants that no assignment of said liens or claims, nor the right to perfect a lien against said real estate, by virtue of the accrual of said payment, has or will be made, and that the undersigned has the right to execute this Partial Waiver and Release, and that all laborers employed by the undersigned, and all bills for materials and supplies furnished by others to the undersigned in connection with the construction of improvements upon the aforesaid premises, to the extent of the payment herein referred to, have been fully paid.

**In witness whereof**, I/we have executed this instrument under seal this \_\_\_\_\_ day of \_\_\_\_\_, 20\_\_\_\_.

(SEAL)

(SEAL)

WITNESS: \_\_\_\_\_

**SECTION 00680 – APPLICATION FOR PAYMENT**

Project: \_\_\_\_\_ Project Number: \_\_\_\_\_  
Payment Request No.: \_\_\_\_\_  
P.O. Number: \_\_\_\_\_  
CONTRACTOR: \_\_\_\_\_ Account No.: \_\_\_\_\_  
Contract Date: \_\_\_\_\_ Completion Date: \_\_\_\_\_  
Application Date: \_\_\_\_\_ Period To: \_\_\_\_\_

**STATEMENT OF WORK**

1. Original Contract \_\_\_\_\_ 6. Total Earned less Retained \_\_\_\_\_  
(Line 4 minus Line 5)  
2. Net Change Orders: \_\_\_\_\_ 7. Less Previous Payments \_\_\_\_\_  
3. Current Contract Total: \_\_\_\_\_ 8. Current Payment Due: \_\_\_\_\_  
(Total of Lines 1 and 2) (Line 6 minus Line 7)  
4. Total Earned to Date: \_\_\_\_\_ 9 Balance to Finish \_\_\_\_\_  
(Total Amount Billed to (Line 3 Minus Line 4)  
Date)  
5. Retainage: \_\_\_\_\_

The undersigned CONTRACTOR hereby swears under penalty of perjury that (1) all previous progress payments received from the OWNER on account of work performed under the Contract referred to above have been applied by the undersigned to discharge in full all obligations of the undersigned incurred in connection with work covered by prior Application for Payment under said contract; and, (2) all materials and equipment incorporated in said Project or otherwise listed in or covered by this Application for Payment are free and clear of all liens, claims, security interests and encumbrances.

by \_\_\_\_\_ Date  
CONTRACTOR



Payment of the amount requested is approved:

by \_\_\_\_\_, \_\_\_\_\_ Date  
City Engineer

by \_\_\_\_\_, \_\_\_\_\_ Date  
Director, Utilities / Public Works Department

## SECTION 00700 – GENERAL CONDITIONS

### 1. SCOPE

The scope of work includes furnishing all labor equipment, tools, materials, and incidentals necessary to complete the work in accordance with the Contract Documents in a first-class workmanlike manner, complete in all respects and ready for use

### 2. APPLICABLE SPECIFICATIONS AND REQUIREMENTS

All work to be performed on this project shall conform to City of Winter Springs and FDOT standard and specifications.

### 3. PERMITS AND REGULATIONS

The CONTRACTOR shall procure and pay for all permits, licenses, and bonds necessary for the prosecution of the Work, and/or required by Municipal, State and Federal regulations, laws and procedures, unless specifically provided otherwise in the Contract Documents. The OWNER shall provide all required easements.

The CONTRACTOR shall give all notices, pay all fees, and comply with all federal, state and municipal laws, ordinances, rules and regulations and building and construction codes bearing on the conduct of the Work. This Contract, as to all matters not particularly referred to and defined herein, shall notwithstanding, be subject to the provisions of all pertinent ordinances, codes and normal regulatory procedures of the municipality or other political subdivision within whose limits the Work is constructed, which ordinances, codes and procedures are hereby made a part hereof with the same force and effect as if specifically set out herein. It is the CONTRACTOR's responsibility to apply to the local jurisdiction for any Building Permit or Permit that may be required.

### 4. PERFORMANCE AND PAYMENT BONDS (See SECTION 00100, PARAGRAPH 1.6 - Notice of Award, Performance Bond and Labor and Materials Payment Bond)

### 5. BID BOND (No Bid Bond is required for this project.)

### 6. INSURANCE AND HOLD HARMLESS INDEMNIFICATION (see SECTION 00500)

Hold Harmless Agreement - To the fullest extent permitted by laws and regulations, CONTRACTOR shall indemnify and hold harmless OWNER and their consultants, agents and employees from and against all claims, damages, losses and expenses, direct, indirect or consequential (including but not limited to fees and charges of engineers, architects, attorneys and other professionals and court and arbitration costs) arising out of or resulting from the performance of the Work, provided that any such claim, damage, loss or expenses (a) is attributable to bodily injury, sickness, disease or death, or to injury to or destruction of tangible property other than the Work itself) including the loss of use resulting therefrom and (b) is caused in whole or in part by any negligent act or omission of Service Provider, any Subcontractor, any person or organization directly or indirectly employed by any of them to perform or furnish any of the Work or anyone for whose acts any of them may be liable, regardless of whether or not it is caused in part by a party indemnified hereunder or arises by or is imposed by Law and Regulations regardless of the negligence of any such party.

In any and all claims against OWNER or any of their consultants, agents or employees by any employee of CONTRACTOR, any Subcontractor, any person or organization directly or indirectly employed by any of them to perform or furnish any of the Work or anyone for whose acts any of them may be liable, the

indemnification obligation under the previous paragraph shall not be limited in any way by any limitation on the amount or type of damages, compensation or benefits payable by or for CONTRACTOR or any such Subcontractor or other person or organization under workers' or workmen's compensation acts, disability benefit acts or other employee benefit acts.

CONTRACTOR's Liability Insurance - The CONTRACTOR shall not commence any work under this Contract until he has obtained all insurance required under the Agreement. CONTRACTOR shall purchase and maintain such comprehensive general liability and other insurance as is appropriate for the Work being performed and furnished and as will provide protection from claims set forth which may arise out of or result from CONTRACTOR's performance and furnishing of the Work and CONTRACTOR's other obligations under the Contract Documents, whether it is to be performed or furnished by CONTRACTOR, by any Subcontractor, by anyone directly or indirectly employed by any of them to perform or furnish any of the Work, or by anyone for whose acts any of them may be liable. The insurance required shall include the specific coverage's and be written for not less than the limits of liability and coverage's provided or required by law, whichever is greater. The comprehensive general liability insurance shall include completed operations insurance. The comprehensive general liability insurance shall also include Contractual Liability Insurance applicable to CONTRACTOR's obligations under the Hold Harmless Indemnification. All of the policies of insurance so required to be purchased and maintained (or the certificates or their evidence thereof) shall contain a provision or endorsement that the coverage afforded will not be canceled, materially changed or renewal refused until at least thirty days' prior written notice has been given to OWNER by certified mail. All such insurance shall remain in effect until final payment and at all times thereafter when CONTRACTOR may be correcting, removing or replacing defective work in accordance with the Contract Documents. CONTRACTOR's General Liability Insurance shall include the OWNER, and OWNER's consultants as insured or additional insured which may be accomplished by either an endorsement of CONTRACTOR's Comprehensive General Liability policy or by CONTRACTOR's carrier issuing a separate protection liability policy.

**7. SALES TAX**

The CONTRACTOR shall include in his bid, and shall pay, all Florida State sales tax and other local, State, and Federal taxes in accordance with existing laws and regulations.

**8. LAYOUT OF WORK**

The CONTRACTOR shall perform and be responsible for all layout work in connection with the project.

**9. CHANGES IN THE WORK**

The OWNER may, at any time, or from time to time, without invalidating the Agreement order alterations, deletions or revisions in the Work by written Change Order or Field Order. Upon receipt of any such order, CONTRACTOR shall promptly proceed with the Work involved, which shall be performed under the applicable conditions of the Contract Documents.

Any deviations from these specifications, plans and contract documents, must be approved by the OWNER in advance of the construction either by a written and executed Change Order or a written Field Order.

The CONTRACTOR agrees that he will do such work as may be required for the proper execution of the whole work herein contemplated, including all labor, equipment and materials reasonably necessary for the proper completion of the work. The CONTRACTOR agrees that he will make no claim for extra work unless that material or work is not covered by, or properly inferable from the Contract Documents. If the CONTRACTOR makes a claim for an extra or additional cost and requests a Change Order be issued prior to performing the

work, and the OWNER renders a decision denying such request, the CONTRACTOR must notify the OWNER in writing within 3 days of the time that the CONTRACTOR is informed of the OWNER's decision. Otherwise the OWNER will not consider any such difference as a claim for a Change Order or additional payment or time. Any such written notice received by the OWNER from the CONTRACTOR within the 3-day period shall be just reason for the OWNER to reevaluate his previous decision.

## **10. PAYMENTS**

The OWNER will make partial payments on a monthly basis to the CONTRACTOR based on pay estimates, which have been approved by the OWNER. The CONTRACTOR shall submit at least three (3) copies of his estimate, with reasonable time allowed to make a field inspection, check, and process the estimate.

Final Payment, including the retainage, will be made upon the completion of the work and certification by the OWNER, and regulatory agencies and acceptance by the OWNER that all of the work has been completed in accordance with the approved plans, specifications, and other Contract Documents, will be made to the CONTRACTOR. The OWNER shall make final Payment not later than 30 days after final acceptance of the work. Prior to final payment, the CONTRACTOR shall transfer to the OWNER all applicable items accumulated throughout construction. These include but are not limited to the following items:

Waivers of lien, releases and other items OWNER may require in evidence of full payment to all SUBCONTRACTORS, suppliers and material-men.

Progress payments may be withheld if:

1. Work is found defective and not remedied;
2. CONTRACTOR does not make prompt and proper payments to SUBCONTRACTORS;
3. CONTRACTOR does not make prompt and proper payments for labor, materials, or equipment furnished;
4. Another CONTRACTOR is damaged by an act for which CONTRACTOR is responsible
5. Claims or liens are filed on the job; or
6. In the opinion of the City of Winter Springs, CONTRACTOR's work is not progressing satisfactorily.

## **11. PAYMENTS WITHHELD**

The OWNER will disburse, and shall have the right to act as agent for the CONTRACTOR in disbursing such funds as have been withheld pursuant to SECTION 00500, PARAGRAPH 11, to the party or parties who are entitled to payment therefrom. The OWNER will render to the CONTRACTOR a proper accounting of all such funds disbursed on behalf of the Contract. Neither the final payment nor any part of the retained percentage shall become due until the CONTRACTOR, if required, shall deliver to the OWNER his written one year guarantee on the work and a complete release of liens arising out of this Contract, or receipts in full in lieu thereof, and, if required in either case, an affidavit that so far as he has knowledge or information, the releases and receipts include all the labor and material for which a lien could be filed; but the CONTRACTOR may, if any subcontractor refuses to sign a release or receipt in full, furnish a bond satisfactory to the OWNER, to indemnify himself against any lien. If any lien remains unsatisfied after all payments are made, the CONTRACTOR shall refund to the OWNER all monies that the latter may be compelled to pay in discharging such a lien, including all costs and a reasonable attorney's fee.

## **12. OWNER'S RIGHT TO TERMINATE THE CONTRACT (see SECTION 00500, PARAGRAPH 8)**

**13. GENERAL GUARANTEE**

All work to be performed under this Contract shall be constructed in compliance with the Contract Documents.

**FIRST AMENDMENT TO TERM CONTRACT FOR  
PAVEMENT MANAGEMENT PROGRAM SERVICES  
(IFB-602096-14/BJC)**

**THIS FIRST AMENDMENT** is made and entered into this 6 day of April, 2015 and is to that certain Agreement made and entered into on the 2<sup>nd</sup> day of December, 2014, between **THE MIDDLESEX CORPORATION**, whose address is One Spectacle Pond Road, Littleton, Massachusetts 01460, hereinafter referred to as "CONTRACTOR", and **SEMINOLE COUNTY**, a political subdivision of the State of Florida, whose address is Seminole County Services Building, 1101 East First Street, Sanford, Florida 32771, hereinafter referred to as "COUNTY".

**WITNESSETH:**

**WHEREAS**, CONTRACTOR and COUNTY entered into the above referenced Agreement on December 2, 2014, for Pavement Management Program services; and

**WHEREAS**, the parties desire to amend the Agreement so as to change the price schedule and to enable both parties to continue to enjoy the mutual benefits the Agreement provides; and

**WHEREAS**, Section 21 of the Agreement provides that any amendments shall be valid only when expressed in writing and duly signed by the parties,

**NOW, THEREFORE**, in consideration of the mutual understandings and agreements contained herein, the parties agree to amend the Agreement as follows:

1. Exhibit A of the Agreement is deleted and replaced by the new Exhibit A attached hereto.
2. Except as herein modified, all terms and conditions of the Agreement shall remain in full force and effect for the term of the Agreement, as originally set forth in said Agreement.

CERTIFIED COPY  
MARYANNE MORSE  
Clerk of Circuit Court and Comptroller  
SEMINOLE COUNTY, FLORIDA  
BY [Signature]  
DEPUTY CLERK

IN WITNESS WHEREOF, the parties hereto have executed this instrument for the purpose herein expressed.

ATTEST:

Peter J. Martinkus  
Peter J. Martinkus, Secretary

(CORPORATE SEAL)

THE MIDDLESEX CORPORATION

By: [Signature]  
DAVID SOCCI, Vice President  
Senior Vice President Estimating

Date: March 26, 2015

SEMINOLE COUNTY, FLORIDA

Sammy Roberts  
Witness  
Sammy Roberts  
Print Name

By: [Signature]  
BETSY COHEN, Purchasing Supervisor

Date: 4/6/15

Gladys Marrozos  
Witness  
Gladys Marrozos  
Print Name

For the use and reliance of Seminole County only.

Approved as to form and legal sufficiency.

[Signature]  
County Attorney

AEC/lpk  
3/23/15  
P:\Users\Legal Secretary CSB\Purchasing 2015\IFB-602096 1.m Middlesex.doc

Attachment:  
Exhibit A - Scope of Services and Cost Structure



**PART A - ROAD CONSTRUCTION PRODUCTS AND RELATED MATERIALS IN-PLACE SERVICES**

IFB-602196-14/BJC

Labor and Materials

**Amendment #1: Revised Description for Asphalt Concrete Friction Course to Include (PG 76-22) PMA**

**Group I: Asphalt Concrete Friction Course In-place**

Pay Item No.	Description	0-50 Tons/Job	51-399 Tons/Job	400 - 1999 Tons/Job	2000 - 3999 Tons/Job	4000 Tons/Job and Over	Sum of Extended Cost
337-7-40	Asphalt Concrete Friction Course Traffic Level B FC-9.5 *(PG 76-22) PMA	Estimated 100 Tons \$ 400.00 /ton Total: \$ 40,000.00	Estimated 300 Tons \$ 200.00 /ton Total: \$ 60,000.00	Estimated 3000 Tons \$ 140.00 /ton Total: \$ 420,000.00	Estimated 5000 Tons \$ 130.00 /ton Total: \$ 650,000.00	Estimated 8000 Tons \$ 130.00 /ton Total: \$ 1,040,000.00	\$ 2,210,000.00
337-7-41	Asphalt Concrete Friction Course Traffic Level B FC-12.5 *(PG 76-22) PMA	Estimated 150 Tons \$ 350.00 /ton Total: \$ 52,500.00	Estimated 700 Tons \$ 175.00 /ton Total: \$ 122,500.00	Estimated 6000 Tons \$ 125.00 /ton Total: \$ 750,000.00	Estimated 8000 Tons \$ 115.00 /ton Total: \$ 920,000.00	Estimated 15000 Tons \$ 115.00 /ton Total: \$ 1,725,000.00	\$ 3,570,000.00
337-7-42	Asphalt Concrete Friction Course Traffic Level C FC-9.5 *(PG 76-22) PMA	Estimated 80 Tons \$ 400.00 /ton Total: \$ 32,000.00	Estimated 300 Tons \$ 200.00 /ton Total: \$ 60,000.00	Estimated 1500 Tons \$ 140.00 /ton Total: \$ 210,000.00	Estimated 3500 Tons \$ 130.00 /ton Total: \$ 455,000.00	Estimated 6000 Tons \$ 130.00 /ton Total: \$ 780,000.00	\$ 1,537,000.00
337-7-43	Asphalt Concrete Friction Course Traffic Level C FC-12.5 *(PG 76-22) PMA	Estimated 80 Tons \$ 350.00 /ton Total: \$ 28,000.00	Estimated 350 Tons \$ 175.00 /ton Total: \$ 61,250.00	Estimated 3000 Tons \$ 125.00 /ton Total: \$ 375,000.00	Estimated 3500 Tons \$ 115.00 /ton Total: \$ 402,500.00	Estimated 8000 Tons \$ 115.00 /ton Total: \$ 920,000.00	\$ 1,786,750.00
337-7-45	Asphalt Concrete Friction Course Traffic Level D FC-12.5 *(PG 76-22) PMA	Estimated 80 Tons \$ 350.00 /ton Total: \$ 28,000.00	Estimated 350 Tons \$ 175.00 /ton Total: \$ 61,250.00	Estimated 3000 Tons \$ 130.00 /ton Total: \$ 390,000.00	Estimated 3500 Tons \$ 120.00 /ton Total: \$ 420,000.00	Estimated 8000 Tons \$ 120.00 /ton Total: \$ 720,000.00	\$ 1,619,250.00

\*Added to Item Description

COMPANY NAME: The Middlesex Corporation

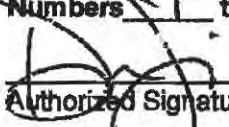

**EXHIBIT A**

<b>SUBMIT BIDS TO:</b> Seminole County 1301 E. Second Street Sanford, Florida 32771 <b>Attn: PURCHASING &amp; CONTRACTS (PCD)</b>	<p align="center"><b>INVITATION FOR BID</b></p> <p align="center">And Bidder Acknowledgment</p>
<b>Contact:</b> Betsy J. Cohen, CPPB Procurement Supervisor 407-665-7112 - Phone 407-665-7956 - Fax bcohen@seminolecountyfl.gov	<p align="center"><b>IFB-602096-14/BJC</b></p> <p align="center"><b>PAVEMENT MANAGEMENT PROGRAM</b></p>
<p align="center"><b><u>Bid Due Date</u></b></p> <p align="center"><b>Date: October 1, 2014</b>  <b>Time: 2:00 PM</b>                  (Eastern Standard Time)</p> <p align="center"><b><u>Location of Public Opening:</u></b>  <b>Purchasing &amp; Contracts Division, Conference Room</b>  <b>1301 E. Second Street, Sanford, FL 32771</b></p>	
<b>Proposer Name:</b> The Middlesex Corporation	<b>Federal Employer ID Number:</b> 04-2534615
<b>Mailing Address:</b> One Spectacle Pond Road	If returning as a "No Submittal", state reason (if so, return only this page):
<b>City, State, Zip:</b> Littleton, MA 01460	
<b>Type of Entity (Circle one):</b> Corporation Partnership Proprietorship Joint Venture Incorporated in the State of: <u>Massachusetts</u> List of Principals: <u>Please See Attachment "A"</u>	The undersigned Bidder hereby acknowledges receipt of Addenda Numbers <u>1</u> through <u>1</u> :  Authorized Signature (Manual)      Date <u>9/24/14</u>
<b>Email Address:</b> dsocci@middlesexco.com	<b>Typed Name:</b> David Socci
<b>Telephone Number:</b> 978-742-4400	<b>Title:</b> Senior Vice President Estimating
<b>Fax Number:</b> 978-742-4434	<b>Date:</b> <u>9/24/14</u>

**THIS FORM MUST BE COMPLETED AND RETURNED WITH WRITTEN BID**

The Bidder is expected to completely analyze the information contained in this Invitation for Bid (IFB) as guidance for the preparation of their written submittal. The Bidder's written bid should be specific, detailed, and complete in order to clearly and fully demonstrate the Bidder's understanding of the requested work and/or delivery requirements.

**Part 4  
Price Submittal**

**IFB-602096-14/BJC – Pavement Management Program**

Name of Bidder: The Middlesex Corporation

Mailing Address: One Spectacle Pond Road

Street Address: Same as Above

City/State/Zip: Littleton, MA 01460

Phone Number: (978) 742-4400 FAX Number: (978) 742-4434

E-Mail Address: dsoccl@middlesexco.com

Pursuant to and in compliance with the IFB Documents, the undersigned Bidder agrees to provide and furnish any and all of the labor, material, tools, equipment, incidentals and transportation services necessary to complete all of the Work required in connection with the Bid Documents for the amount hereinafter set forth. Bidder declares that the only persons or parties interested in this bid as principals are those named herein; that this bid is made without collusion with any person, firm or corporation; and he proposes and agrees, if the bid is accepted, that he/she will accept to enter into an Agreement with the COUNTY in the form set forth in the Purchase Order and solicitation Documents. The cost of the units shall include all costs, including but not limited to:

- General Administrative Overhead, fringe and benefits and profit, all documentation required for operation, delivery/transportation of unit(s) to the County's delivery address, indirect costs, i.e., insurance, etc., indirect labor costs

Group I includes Asphalt	Subtotal: \$ <u>20,610,200.<sup>00</sup></u>
Group II is "Sand and Seal in-place"	Subtotal: \$ <u>266,500.<sup>00</sup></u>
Group III is "Milling"	Subtotal: \$ <u>289,000.<sup>00</sup></u>
Group IV is "Striping"	Subtotal: \$ <u>79,600.<sup>00</sup></u>
Group V is "Miscellaneous Items"	Subtotal: \$ <u>385,000.<sup>00</sup></u>
Group VI Asphalt Materials (materials only)	Subtotal: \$ <u>398,800.<sup>00</sup></u>
Group VII Earthwork	Subtotal: \$ <u>832,000.<sup>00</sup></u>
<b>TOTAL BID:</b>	<b>\$ <u>22,861,100.<sup>00</sup></u></b>
Performance/Payment/Material-Workmanship Bonds Costs: \$	<u>197,000.<sup>00</sup></u>
(Do not include in Unit Costs)	



IFB-602096-14/BJC - Pavement Management Program

PART A - ROAD CONSTRUCTION PRODUCTS AND RELATED MATERIALS IN-PLACE SERVICES

Labor and Materials

Group I: Asphalt Concrete, Surface Treatment and Friction Course In-place

Pay Item No.	Description	0-50 Tons/Job	51-399 Tons/Job	400 - 1999 Tons/Job	2000 - 3999 Tons/Job	4000 Tons/Job and Over	Sum of Extended Cost
334-1-12	Superpave Asphaltic Concrete Traffic Level B	Estimated 100 Tons \$ 300.00 /ton Total: \$ 30,000.00	Estimated 500 Tons \$ 150.00 /ton Total: \$ 75,000.00	Estimated 2400 Tons \$ 94.00 /ton Total: \$ 225,600.00	Estimated 6000 Tons \$ 85.00 /ton Total: \$ 510,000.00	Estimated 8000 Tons \$ 82.00 /ton Total: \$ 656,000.00	\$ 1,474,600.00
334-1-13	Superpave Asphaltic Concrete Traffic Level C	Estimated 150 Tons \$ 300.00 /ton Total: \$ 45,000.00	Estimated 800 Tons \$ 150.00 /ton Total: \$ 120,000.00	Estimated 5000 Tons \$ 94.00 /ton Total: \$ 470,000.00	Estimated 7000 Tons \$ 90.00 /ton Total: \$ 630,000.00	Estimated 20000 Tons \$ 90.00 /ton Total: \$ 1,800,000.00	\$ 3,085,000.00
334-1-22	Superpave Asphaltic Concrete Traffic Level B (PG 78-22) PMA	Estimated 100 Tons \$ 350.00 /ton Total: \$ 35,000.00	Estimated 400 Tons \$ 170.00 /ton Total: \$ 68,000.00	Estimated 3000 Tons \$ 115.00 /ton Total: \$ 345,000.00	Estimated 6000 Tons \$ 110.00 /ton Total: \$ 660,000.00	Estimated 9000 Tons \$ 110.00 /ton Total: \$ 990,000.00	\$ 1,928,000.00
334-1-23	Superpave Asphaltic Concrete Traffic Level C (PG 78-22) PMA	Estimated 100 Tons \$ 350.00 /ton Total: \$ 35,000.00	Estimated 800 Tons \$ 170.00 /ton Total: \$ 136,000.00	Estimated 5000 Tons \$ 115.00 /ton Total: \$ 575,000.00	Estimated 7300 Tons \$ 112.00 /ton Total: \$ 817,600.00	Estimated 15000 Tons \$ 112.50 /ton Total: \$ 1,687,500.00	\$ 3,217,100.00
337-7-40	Asphalt Concrete Friction Course FC-8.5 Traffic Level B	Estimated 100 Tons \$ 400.00 /ton Total: \$ 40,000.00	Estimated 300 Tons \$ 300.00 /ton Total: \$ 90,000.00	Estimated 3000 Tons \$ 140.00 /ton Total: \$ 420,000.00	Estimated 5000 Tons \$ 130.00 /ton Total: \$ 650,000.00	Estimated 8000 Tons \$ 130.00 /ton Total: \$ 1,040,000.00	\$ 2,210,000.00
337-7-41	Asphalt Concrete Friction Course FC-12.5 Traffic Level B	Estimated 150 Tons \$ 350.00 /ton Total: \$ 52,500.00	Estimated 700 Tons \$ 175.00 /ton Total: \$ 122,500.00	Estimated 8000 Tons \$ 125.00 /ton Total: \$ 1,000,000.00	Estimated 8000 Tons \$ 115.00 /ton Total: \$ 920,000.00	Estimated 15000 Tons \$ 115.00 /ton Total: \$ 1,725,000.00	\$ 3,570,000.00
337-7-42	Asphalt Concrete Friction Course FC-8.5 Traffic Level C	Estimated 80 Tons \$ 400.00 /ton Total: \$ 32,000.00	Estimated 300 Tons \$ 300.00 /ton Total: \$ 90,000.00	Estimated 1500 Tons \$ 140.00 /ton Total: \$ 210,000.00	Estimated 3500 Tons \$ 130.00 /ton Total: \$ 455,000.00	Estimated 6000 Tons \$ 130.00 /ton Total: \$ 780,000.00	\$ 1,537,000.00

Company Name: The Middlesex Corporation

Addendum #1 Received 9/24/14



IFB-602096-14/BJC - Pavement Management Program

PART A - ROAD CONSTRUCTION PRODUCTS AND RELATED MATERIALS IN-PLACE SERVICES

Labor and Materials

Group I: Asphalt Concrete, Surface Treatment and Friction Course In-place

Pay Item No.	Description	0-50 Tons/Job	51-399 Tons/Job	400 - 1999 Tons/Job	2000 - 3999 Tons/Job	4000 Tons/Job and Over	Sum of Extended Cost
337-7-43	Asphalt Concrete Friction Course FC-12.5 Traffic Level C	Estimated 80 Tons \$ 350. <sup>00</sup> /ton Total: \$ 28,000. <sup>00</sup>	Estimated 350 Tons \$ 175. <sup>00</sup> /ton Total: \$ 61,250. <sup>00</sup>	Estimated 3000 Tons \$ 125. <sup>00</sup> /ton Total: \$ 375,000. <sup>00</sup>	Estimated 3500 Tons \$ 115. <sup>00</sup> /ton Total: \$ 402,500. <sup>00</sup>	Estimated 8000 Tons \$ 115. <sup>00</sup> /ton Total: \$ 920,000. <sup>00</sup>	\$1,786,750. <sup>00</sup>
337-7-45	Asphalt Concrete Friction Course FC-12.5 Traffic Level D	Estimated 80 Tons \$ 350. <sup>00</sup> /ton Total: \$ 28,000. <sup>00</sup>	Estimated 350 Tons \$ 175. <sup>00</sup> /ton Total: \$ 61,250. <sup>00</sup>	Estimated 3000 Tons \$ 130. <sup>00</sup> /ton Total: \$ 390,000. <sup>00</sup>	Estimated 3500 Tons \$ 120. <sup>00</sup> /ton Total: \$ 420,000. <sup>00</sup>	Estimated 6000 Tons \$ 120. <sup>00</sup> /ton Total: \$ 720,000. <sup>00</sup>	\$1,619,250. <sup>00</sup>
901-337-8	Bonded Asphalt Concrete Friction Course FC-5 (PG-78-22) Section 327B	Estimated 150 Tons \$ _____ /ton Total: \$ _____	Estimated 450 Tons \$ _____ /ton Total: \$ _____	Estimated 2400 Tons \$ _____ /ton Total: \$ _____	Estimated 3500 Tons \$ _____ /ton Total: \$ _____	Estimated 8000 Tons \$ _____ /ton Total: \$ _____	\$ _____
339-1	Miscellaneous Asphalt Pavement	Estimated 200 Tons \$ 300. <sup>00</sup> /ton Total: \$ 60,000. <sup>00</sup>	Estimated 500 Tons \$ 225. <sup>00</sup> /ton Total: \$ 112,500. <sup>00</sup>				\$172,500. <sup>00</sup>
<b>TOTAL FOR GROUP I</b>							<b>\$2,171,500.<sup>00</sup></b>



## IFB-602096-14/BJC - Pavement Management Program

## Group II: Sand and Seal in-place

Pay Item No.	Description	0-999 SY / Per Job	1000-1999 SY / Per Job	2000-2999 SY / Per Job	3000 SY and Over / Per Job	Sum of Extended Cost
2-1	Prime and Sand  (Section 916)	Estimated 500 SY: \$ 4.00 /SY Total: \$ 2,000.00	Estimated 1000 SY: \$ 2.00 /SY Total: \$ 2,000.00	Estimated 2000 SY: \$ 1.00 /SY Total: \$ 2,000.00	Estimated 3000 SY: \$ 0.50 /SY Total: \$ 1,500.00	\$ 7,500.00
341-70	Asphalt Rubber Membrane Interlayer (ARMI)  (Section 341)	Estimated 500 SY: \$ 25.00 /SY Total: \$ 12,500.00	Estimated 1000 SY: \$ 15.00 /SY Total: \$ 15,000.00	Estimated 2000 SY: \$ 11.00 /SY Total: \$ 22,000.00	Estimated 3000 SY: \$ 10.00 /SY Total: \$ 30,000.00	\$ 119,500.00
908-340-1	Open Graded Crack Relief Layer  (Dev Spec Section 340)	Estimated 500 SY: \$ 25.00 /SY Total: \$ 12,500.00	Estimated 2000 SY: \$ 14.00 /SY Total: \$ 28,000.00	Estimated 5000 SY: \$ 11.00 /SY Total: \$ 55,000.00	Estimated 8000 SY: \$ 10.50 /SY Total: \$ 84,000.00	\$ 179,500.00
TOTAL FOR GROUP II						\$ 266,500.00

Company Name: The Middlesex Corporation





IFB-602096-14/BJC - Pavement Management Program

Group III: Milling existing asphalt pavement in-place

Pay Item No.	Description	0-999 SY / Per Job	1000-1999 SY / Per Job	2000-2999 SY / Per Job	3000 SY and Over / Per Job	Sum of Extended Cost
327-70A	Milling Existing Asphalt Pavement (Milled Material becomes property of Contractor)	Estimated 1000 SY/Inch: \$ 10. <sup>00</sup> /SY Total: \$ 10,000. <sup>00</sup>	Estimated 2000 SY/Inch: \$ 6. <sup>00</sup> /SY Total: \$ 12,000. <sup>00</sup>	Estimated 8000 SY/Inch: \$ 2.50 /SY Total: \$ 20,000. <sup>00</sup>	Estimated 20,000 SY/Inch: \$ 2.50 /SY Total: \$ 50,000. <sup>00</sup>	\$ 92,000. <sup>00</sup>
327-70B	Milling Existing Asphalt Pavement (Yankee Lake) Material delivered to Yankee Lake Yard in Sanford at: 501 Yankee Lake Rd. Sanford FL, 32771	Estimated 1000 SY/Inch: \$ 12. <sup>00</sup> /SY Total: \$ 12,000. <sup>00</sup>	Estimated 2000 SY/Inch: \$ 6.50 /SY Total: \$ 13,000. <sup>00</sup>	Estimated 8000 SY/Inch: \$ 3.00 /SY Total: \$ 18,000. <sup>00</sup>	Estimated 10,000 SY/Inch: \$ 2.50 /SY Total: \$ 25,000. <sup>00</sup>	\$ 68,000. <sup>00</sup>
327-70C	Milling Existing Asphalt Pavement (Oviedo Yard) Material delivered to County Yard in Oviedo at: 1820 N. County Rd 428 Oviedo, FL 32765	Estimated 1000 SY/Inch: \$ 12. <sup>00</sup> /SY Total: \$ 12,000. <sup>00</sup>	Estimated 2000 SY/Inch: \$ 6.50 /SY Total: \$ 13,000. <sup>00</sup>	Estimated 8000 SY/Inch: \$ 3. <sup>00</sup> /SY Total: \$ 18,000. <sup>00</sup>	Estimated 10,000 SY/Inch: \$ 2.50 /SY Total: \$ 25,000. <sup>00</sup>	\$ 68,000. <sup>00</sup>
327-70D	Milling Existing Asphalt Pavement (Relocate) Milled Material delivered to location within 5 miles of project limits	Estimated 1000 SY/Inch: \$ 10. <sup>00</sup> /SY Total: \$ 10,000. <sup>00</sup>	Estimated 2000 SY/Inch: \$ 6. <sup>00</sup> /SY Total: \$ 12,000. <sup>00</sup>	Estimated 8000 SY/Inch: \$ 2.75 /SY Total: \$ 11,250. <sup>00</sup>	Estimated 10,000 SY/Inch: \$ 2.25 /SY Total: \$ 22,500. <sup>00</sup>	\$ 66,000. <sup>00</sup>
<b>TOTAL FOR GROUP III</b>						<b>\$ 287,000.<sup>00</sup></b>

Company Name: The Middlesex Corporation



## IFB-802096-14/BJC - Pavement Management Program

## Group IV: Temporary Pavement Marking In-place

Pay Item No.	Description	Quantity	Sum of Extended Cost
102-78	Temporary Retroreflective Pavement Markers	Estimated 2500 EA: \$ <u>5.00</u> /Each	\$ 12,500.00
102-911-2	Removable Tape (White/Black) - 8"	Estimated 6000 LF: \$ <u>2.50</u> /LF	\$ 12,500.00
102-912-2	Removable Tape (Yellow) - 8"	Estimated 6000 LF: \$ <u>2.50</u> /LF	\$ 12,500.00
710-11-111	Temporary Pavement Marking - Paint - White Solid Stripe 6"	Estimated 10,000 LF: \$ <u>0.50</u> /LF	\$ 5,000.00
710-11-141	Temporary Pavement Marking - Paint - White Skip Stripe 6"	Estimated 3000 LF: \$ <u>1.00</u> /LF	\$ 3,000.00
710-11-221	Temporary Pavement Marking - Paint - Yellow Solid Stripe 6"	Estimated 15,000 LF: \$ <u>0.50</u> /LF	\$ 7,500.00
710-11-241	Temporary Pavement Marking - Paint - Yellow Skip Stripe 6"	Estimated 6000 LF: \$ <u>1.00</u> /LF	\$ 6,000.00
710-11-123	Temporary Pavement Marking - Paint - 12" White	Estimated 6000 LF: \$ <u>0.75</u> /LF	\$ 3,750.00
710-11-125	Temporary Pavement Marking - Paint - Stop Bar 24" White	Estimated 3000 LF: \$ <u>1.50</u> /LF	\$ 4,500.00
710-11-910	Temporary Pavement Marking - Paint - School Zone	Estimated 24 EA: \$ <u>200.00</u> /Each	\$ 4,800.00
710-11-920	Temporary Pavement Marking - Paint - Railroad Crossing	Estimated 24 EA: \$ <u>200.00</u> /Each	\$ 4,800.00
710-11-170	Temporary Pavement Marking - Paint - White Arrows	Estimated 50 EA: \$ <u>75.00</u> /Each	\$ 3,750.00
TOTAL FOR GROUP IV			\$ 79,600.00

Company Name: The Middlesex Corporation



## IFB-602096-14/BJC - Pavement Management Program

## Group V: Miscellaneous Items, Mobilization, MOT, Speed humps, Utility Adjustment

Pay Item No.	Description	Quantity	Sum of Extended Cost
5-1	Liquidated Damages LD (For Major Roads) (For use only with projects having a defined time to completion as advertised in the individual bid for that project) (Section 6 and 11)	Estimated 1 each -1,000.00 ED Total -\$1,000.00	Do not include this in bid total
5-2	Liquidated Damages LD (For Minor Streets/Roads) (For use only with projects having a defined time to completion as advertised in the individual bid for that project) (Section 6 and 11)	Estimated 1 each -\$500.00 ED Total -\$500.00	Do not include this in bid total
101-1	Mobilization Charge (not to exceed 5% of contract total) Includes labor/equipment/materials	Estimated 30 each day \$ 3,000.00 /day Total \$ 1,140,000.00	Do not include this in bid total
101-2	Mobilization Charge for 24-hour emergency response. Includes labor/equipment/materials	Estimated 30 each day \$ 3,500.00 /day	\$ 105,000.00
102-1	Maintenance of Traffic Includes labor/equipment/materials (not to exceed \$1500 per day)	Estimated 30 ED \$ 1,500.00 /day	\$ 45,000.00
102-14	Traffic Control Officer	Estimated 100 HR \$ 15.00 /Hours	\$ 1,500.00
102-99	Portable Changeable Message Sign	Estimated 1000 ED \$ 35.00 /day	\$ 35,000.00
121-70	Flowable Fill Includes labor/equipment/materials	Estimated 1000 CY \$ 185.00 /CY	\$ 185,000.00
425-8	Water Valve or similar cover adjustment	Estimated 25 each: \$ 100.00 /Each	\$ 2,500.00
425-7	Manhole Ring Adjustment	Estimated 25 each: \$ 200.00 /Each	\$ 5,000.00
TOTAL FOR GROUP V			\$ 385,000.00

Company Name: The Middlesex Corporation





## IFB-602096-14/BJC - Pavement Management Program

FOB Items > Materials Only**Group VI: Asphalt Materials (materials only)**

Pay Item No.	Description	FOB Plant	FOB Job Site	Sum of Extended Cost
6-1	SP-12.5 Hot Mix Asphaltic Concrete (Section 334)	Estimated 1000 Tons \$ 52.00 /Ton Total: \$ 52,000.00	Estimated 200 Tons \$ 42.50 /Ton Total: \$ 12,500.00	\$ 64,500.00
6-2	SP-9.5 Hot Mix Asphaltic Concrete (Section 334)	Estimated 1000 Tons \$ 55.00 /Ton Total: \$ 55,000.00	Estimated 200 Tons \$ 64.00 /Ton Total: \$ 12,800.00	\$ 67,800.00
6-3	SP-4.75 Hot Mix Asphaltic Concrete (Section 334)	Estimated 1000 Tons \$ 70.00 /Ton Total: \$ 70,000.00	Estimated 1000 Tons \$ 85.00 /Ton Total: \$ 85,000.00	\$ 155,000.00
6-4	Superpave Asphalt Concrete FC-12.5 > Granite Aggregate (with PG 78-22) (Section 337)	Estimated 200 Tons \$ 90.00 /Ton Total: \$ 18,000.00	Estimated 200 Tons \$ 105.00 /Ton Total: \$ 21,000.00	\$ 39,000.00
6-5	Superpave Asphalt Concrete FC-9.5 > Granite Aggregate (with PG 78-22) (Section 337)	Estimated 200 Tons \$ 90.00 /Ton Total: \$ 18,000.00	Estimated 200 Tons \$ 105.00 /Ton Total: \$ 21,000.00	\$ 39,000.00
6-8	Asphalt Milling Material	Estimated 500 Tons \$ 25.00 /Ton Total: \$ 12,500.00	Estimated 500 Tons \$ 55.00 /Ton Total: \$ 27,500.00	\$ 30,000.00
6-7	Tack Type RS-1/RS-2	Estimated 1000 Gallons \$ 3.50 /Gal Total: \$ 3,500.00		\$ 3,500.00
<b>TOTAL FOR GROUP VI</b>				<b>\$ 398,800.00</b>

Asphalt can be S-I or S-III Marshall Mix at Seminole County Approval.

Company Name: The Middlesex Corporation

**TERM CONTRACT FOR PAVEMENT MANAGEMENT PROGRAM SERVICES  
(IFB-602096-14/BJC)**

**THIS AGREEMENT** is dated as of the 2 day of December 2014, by and between **THE MIDDLESEX CORPORATION**, duly authorized to conduct business in the State of Florida, whose address is One Spectacle Pond Road, Littleton, Massachusetts 01460, hereinafter referred to as "CONTRACTOR", and **SEMINOLE COUNTY**, a political subdivision of the State of Florida, whose address is Seminole County Services Building, 1101 East First Street, Sanford, Florida 32771, hereinafter referred to as "COUNTY".

**WITNESSETH:**

**WHEREAS**, COUNTY desires to retain the services of a competent and qualified contractor to provide Pavement Management Program services to COUNTY; and

**WHEREAS**, COUNTY has requested and received expressions of interest for the retention of services of contractors; and

**WHEREAS**, CONTRACTOR is competent and qualified to provide Pavement Management Program services to COUNTY and desires to provide services according to the terms and conditions stated herein,

**NOW, THEREFORE**, in consideration of the mutual understandings and covenants set forth herein, COUNTY and CONTRACTOR agree as follows:

**Section 1. Services.** COUNTY does hereby retain CONTRACTOR to furnish materials and services as further described in the Scope of Services attached hereto as Exhibit A and made a part hereof. CONTRACTOR shall also be bound by all requirements as contained in the solicitation package and all addenda thereto. Required materials and services shall be specifically enumerated, described, and depicted in the Release Orders authorizing purchase of specific

materials and services. This Agreement standing alone does not authorize the purchase of materials and services or require COUNTY to place any orders for work.

**Section 2. Term.** This Agreement shall take effect on the date of its execution by COUNTY and shall run for a period of three (3) years. At the sole option of COUNTY, this Agreement may be renewed for two (2) successive periods not to exceed one (1) year each. Expiration of the term of this Agreement shall have no effect upon Release Orders issued pursuant to this Agreement and prior to the expiration date. Obligations entered therein by both parties shall remain in effect until delivery and acceptance of the materials authorized by the Release Order. The first three (3) months of the initial term shall be considered probationary. During the probationary period, COUNTY may immediately terminate this Agreement at any time, with or without cause, upon written notice to CONTRACTOR.

**Section 3. Authorization for Services.** Authorization for provision of materials and services by CONTRACTOR under this Agreement shall be in the form of written Release Orders issued and executed by COUNTY. A sample Release Order is attached hereto as Exhibit B. Each Release Order shall describe the materials and services required and shall state the dates for delivery of materials and services and establish the amount and method of payment. The Release Orders will be issued under and shall incorporate the terms of this Agreement. COUNTY makes no covenant or promise as to the number of available Release Orders or that CONTRACTOR will perform any Release Order for COUNTY during the life of this Agreement. COUNTY reserves the right to contract with other parties for the services contemplated by this Agreement when it is determined by COUNTY to be in the best interest of COUNTY to do so.

All contractors will be invited to participate in the quoting process for each project as directed by the COUNTY Representative. Detailed technical information will be provided to each

contractor, and they will have the opportunity to submit a quote based on the not-to-exceed price structure established in the agreements. The final bids will be normally submitted on either a lump sum or unit price basis, as stipulated by the COUNTY Representative. A lump sum bid will represent the total price for which a contractor offers to complete the work according to the detailed plans and specifications. Unit price bidding will be used in projects for which the quantity of materials or the amount of labor involved in some key tasks is particularly uncertain. In such cases, the contractors will be allowed to submit a list of unit prices for those tasks, computed by multiplying the quoted unit price for each specified task by the corresponding quantity in the COUNTY Representative's estimates for quantities. However, the total payment to the selected contractor will be based on the actual quantities multiplied by the respective quoted unit prices.

**Section 4. Time for Completion.** The materials and services to be provided by CONTRACTOR shall be delivered, as specified in such Release Orders as may be issued hereunder, within the time specified therein.

**Section 5. Compensation.** COUNTY agrees to compensate CONTRACTOR for the professional services provided for under this Agreement on a Fixed Fee basis. When a Release Order is issued for a Fixed Fee basis, then the applicable Release Order Fixed Fee amount shall include any and all reimbursable expenses. The total annual compensation paid to CONTRACTOR pursuant to this Agreement, including reimbursable expenses, shall not exceed COUNTY's allocated budget for pavement management.



**Section 6. Payment and Billing.**

(a) CONTRACTOR shall supply all materials and services required by the Release Order; but in no event shall CONTRACTOR be paid more than the negotiated Fixed Fee amount stated within each Release Order.

(b) For Release Orders issued on a Fixed Fee basis, CONTRACTOR may invoice the amount due based on the percentage of total Release Order materials and services actually provided; but in no event shall the invoice amount exceed a percentage of the Fixed Fee amount equal to a percentage of the total services actually completed.

(c) Payments shall be made by COUNTY to CONTRACTOR when requested as materials and services are furnished but not more than once monthly. Each Release Order shall be invoiced separately. At the close of each calendar month, CONTRACTOR shall render to COUNTY an itemized invoice, properly dated, describing any materials and services provided, the cost of the materials and services therein, the name and address of CONTRACTOR, Release Order Number, Contract Number and any other information required by this Agreement.

The original invoice and one (1) copy shall be sent to:

Director of County Finance  
Seminole County Board of County Commissioners  
Post Office Box 8080  
Sanford, Florida 32772

Two (2) copies of the invoice shall be sent to:

Seminole County Public Works Department  
1101 East First Street  
Sanford, Florida 32771

(d) Upon review and approval of CONTRACTOR's invoice, COUNTY shall, in accordance with the terms as set forth in Chapter 218, Part VII, Florida Statutes, pay CONTRACTOR the approved amount.

**Section 7. General Terms of Payment and Billing.**

(a) Upon satisfactory delivery of materials and services required hereunder and upon acceptance of the materials and services by COUNTY, CONTRACTOR may invoice COUNTY for the full amount of compensation provided for under the terms of this Agreement less any amount already paid by COUNTY. Upon review and approval of CONTRACTOR's invoice, COUNTY shall, in accordance with the terms as set forth in Chapter 218, Part VII, Florida Statutes, pay CONTRACTOR the approved amount.

(b) COUNTY may perform or have performed an audit of the records of CONTRACTOR at any time during the term of this Agreement and after final payment to support final payment hereunder. Audits may be performed at a time mutually agreeable to CONTRACTOR and COUNTY. Total compensation to CONTRACTOR may be determined subsequent to an audit as provided for herein and the total compensation so determined shall be used to calculate final payment to CONTRACTOR. Conduct of this audit shall not delay final payment as provided by this Section.

(c) CONTRACTOR agrees to maintain all books, documents, papers, accounting records and other evidence pertaining to materials and services provided under this Agreement in such a manner as will readily conform to the terms of this Agreement and to make such materials available at CONTRACTOR's office at all reasonable times during the Agreement period and for five (5) years from the date of final payment under the contract for audit or inspection as provided for in subsection (b) of this Section.

(d) In the event any audit or inspection conducted after final payment but within the period provided in paragraph (c) of this Section reveals any overpayment by COUNTY under the

terms of the Agreement, CONTRACTOR shall refund such overpayment to COUNTY within thirty (30) days of notice by COUNTY.

**Section 8. Responsibilities of CONTRACTOR.** Neither COUNTY's review, approval or acceptance of, nor payment for any of the materials and services required shall be construed to operate as a waiver of any rights under this Agreement or of any cause of action arising out of the performance of this Agreement. CONTRACTOR shall be and always remain liable to COUNTY in accordance with applicable law for any and all damages to COUNTY caused by CONTRACTOR's negligent or wrongful provision of any of the materials and services furnished under this Agreement.

**Section 9. Termination.**

(a) COUNTY may, by written notice to CONTRACTOR terminate this Agreement or any Release Order issued hereunder, in whole or in part, at any time, either for COUNTY's convenience or because of the failure of CONTRACTOR to fulfill its Agreement obligations. Upon receipt of such notice, CONTRACTOR shall immediately discontinue all services affected, unless the notice directs otherwise, and deliver to COUNTY all data, drawings, specifications, reports, estimates, summaries and any and all such other information and materials of whatever type or nature as may have been accumulated by CONTRACTOR in performing this Agreement, whether completed or in process.

(b) If the termination is for the convenience of COUNTY, CONTRACTOR shall be paid compensation for services performed to the date of termination.

(c) If the termination is due to the failure of CONTRACTOR to fulfill its agreement obligations, COUNTY may take over the work and prosecute the same to completion by other agreements or otherwise. In such case, CONTRACTOR shall be liable to COUNTY for all



reasonable additional costs occasioned to COUNTY thereby. CONTRACTOR shall not be liable for such additional costs if the failure to perform the Agreement arises without any fault or negligence of CONTRACTOR; provided, however, that CONTRACTOR shall be responsible and liable for the actions of its subcontractors, agents, employees, persons and entities of a similar type or nature. Such causes may include acts of God or of the public enemy, acts of COUNTY in its sovereign or contractual capacity, fires, floods, epidemics, quarantine restrictions, strikes, freight embargoes, and unusually severe weather; but in every case the failure to perform must be beyond the control and without any fault or negligence of CONTRACTOR.

(d) If after notice of termination for failure to fulfill its Agreement obligations it is determined that CONTRACTOR had not so failed, the termination shall be conclusively deemed to have been effected for the convenience of COUNTY. In such event, adjustment in the Agreement price shall be made as provided in subsection (b) of this Section.

(e) The rights and remedies of COUNTY provided for in this Section are in addition and supplemental to any and all other rights and remedies provided by law or under this Agreement.

**Section 10. Agreement and Release Order in Conflict.** Whenever the terms of this Agreement conflict with any Release Order issued pursuant to it, this Agreement shall prevail.

**Section 11. Equal Opportunity Employment.** CONTRACTOR agrees that it will not discriminate against any employee or applicant for employment for work under this Agreement because of race, color, religion, sex, age, disability or national origin and will take steps to ensure that applicants are employed and employees are treated during employment without regard to race, color, religion, sex, age, disability, or national origin. This provision shall include, but not be limited to the following: employment, upgrading, demotion or transfer, recruitment advertising,

layoff or termination, rates of pay or other forms of compensation and selection for training including apprenticeship.

**Section 12. No Contingent Fees.** CONTRACTOR warrants that it has not employed or retained any company or person other than a bona fide employee working solely for CONTRACTOR to solicit or secure this Agreement and that it has not paid or agreed to pay any person, company, corporation, individual or firm other than a bona fide employee working solely for CONTRACTOR any fee, commission, percentage, gift or other consideration contingent upon or resulting from award or making of this Agreement. For the breach or violation of this provision, COUNTY shall have the right to terminate the Agreement at its sole discretion without liability and to deduct from the Agreement price or otherwise recover the full amount of such fee, commission, percentage, gift or consideration.

**Section 13. Conflict of Interest.**

(a) CONTRACTOR agrees that it will not contract for or accept employment for the performance of any work or service with any individual, business, corporation or government unit that would create a conflict of interest in the performance of its obligations pursuant to this Agreement with COUNTY.

(b) CONTRACTOR agrees that it will neither take any action nor engage in any conduct that would cause any COUNTY employee to violate the provisions of Chapter 112, Florida Statutes, relating to ethics in government.

(c) In the event that CONTRACTOR causes or in any way promotes or encourages a COUNTY officer, employee or agent to violate Chapter 112, Florida Statutes, COUNTY shall have the right to terminate this Agreement.

**Section 14. Assignment.** This Agreement nor any interest herein shall not be assigned, transferred, or otherwise encumbered under any circumstances by the parties hereto without prior written consent of the other party and in such cases only by a document of equal dignity herewith.

**Section 15. Subcontractors.** In the event that CONTRACTOR during the course of the work under this Agreement requires the services of subcontractors or other professional associates in connection with services covered by this Agreement, CONTRACTOR must first secure the prior express written approval of COUNTY. If subcontractors or other professional associates are required in connection with the services covered by this Agreement, CONTRACTOR shall remain fully responsible for the services of subcontractors or other professional associates.

**Section 16. Indemnification of COUNTY.** CONTRACTOR agrees to hold harmless and indemnify COUNTY and its commissioners, officers, employees and agents against any and all claims, losses, damages or lawsuits for damages arising from, allegedly arising from or related to the provision of services hereunder by CONTRACTOR.

**Section 17. Insurance.**

(a) **General.** CONTRACTOR shall, at its own cost, procure insurance required under this Section.

(1) CONTRACTOR shall furnish COUNTY with a Certificate of Insurance on a current ACORD Form signed by an authorized representative of the insurer evidencing the insurance required by this Section (Professional Liability, Workers' Compensation/Employer's Liability, Commercial General Liability, and Business Auto). COUNTY, its officials, officers, and employees shall be named additional insured under the Commercial General Liability policy. If the policy provides for a blanket additional insured coverage, please provide a copy of the section of the policy along with the Certificate of Insurance. If the coverage does not exist, the

policy must be endorsed to include the additional insured verbiage. The Certificate of Insurance shall provide that COUNTY shall be given, by policy endorsement, not less than thirty (30) days written notice prior to the cancellation or non-renewal or by a method acceptable to COUNTY. Until such time as the insurance is no longer required to be maintained by CONTRACTOR, CONTRACTOR shall provide COUNTY with a renewal or replacement Certificate of Insurance before expiration or replacement of the insurance for which a previous Certificate of Insurance has been provided.

(2) The Certificate of Insurance shall contain a statement that it is being provided in accordance with this Agreement and that the insurance is in full compliance with the insurance requirements of this Agreement. **The Certificate of Insurance shall have this Agreement number clearly marked on its face.**

(3) In addition to providing the Certificate of Insurance on a current ACORD Form, upon request as required by COUNTY, CONTRACTOR shall, within thirty (30) days after receipt of the request, provide COUNTY with a certified copy of each of the policies of insurance providing the coverage required by this Section. Certified copies of policies may only be provided by the Insurer, not the agent/broker.

(4) Neither approval by COUNTY, nor failure to disapprove the insurance furnished by CONTRACTOR, shall relieve CONTRACTOR of its full responsibility for performance of any obligation including CONTRACTOR's indemnification of COUNTY under this Agreement.

(b) Insurance Company Requirements. Insurance companies providing the insurance under this Agreement must meet the following requirements:

(1) Companies issuing policies (other than Workers' Compensation) must be authorized to conduct business in the State of Florida and prove same by maintaining Certificates of Authority issued to the companies by the Florida Office of Insurance Regulation.

(2) In addition, such companies shall have and maintain, at a minimum, a Best's Rating of "A-" and a minimum Financial Size Category of "VII" according to A.M. Best Company.

(3) If, during the period which an insurance company is providing the insurance coverage required by this Agreement, an insurance company shall: (i) lose its Certificate of Authority; or (ii) fail to maintain the requisite Best's Rating and Financial Size Category, CONTRACTOR shall, as soon as CONTRACTOR has knowledge of any such circumstance, immediately notify COUNTY and immediately replace the insurance coverage provided by the insurance company with a different insurance company meeting the requirements of this Agreement. Until such time as CONTRACTOR has replaced the unacceptable insurer with an insurer acceptable to COUNTY, CONTRACTOR shall be deemed to be in default of this Agreement.

(c) Specifications. Without limiting any of the other obligations or liability of CONTRACTOR, CONTRACTOR shall, at its sole expense, procure, maintain, and keep in force amounts and types of insurance conforming to the minimum requirements set forth in this subsection. Except as otherwise specified in this Agreement, the insurance shall become effective upon execution of this Agreement by CONTRACTOR and shall be maintained in force until the expiration of this Agreement's term and/or the expiration of all Work Orders issued under this Agreement, whichever comes first. Failure by CONTRACTOR to maintain insurance coverage within the stated period and in compliance with insurance requirements of COUNTY



shall constitute a material breach of this Agreement, for which this Agreement may be immediately terminated by COUNTY. The amounts and types of insurance shall conform to the following minimum requirements:

(1) Workers' Compensation/Employer's Liability.

(A) CONTRACTOR's insurance shall cover CONTRACTOR for liability which would be covered by the latest edition of the standard Workers' Compensation policy as filed for use in Florida by the National Council on Compensation Insurance, without restrictive endorsements. CONTRACTOR will also be responsible for procuring proper proof of coverage from its subcontractors of every tier for liability which is a result of a Workers' Compensation injury to the subcontractor's employees. The minimum required limits to be provided by both CONTRACTOR and its subcontractors are outlined in subsection (C) below. In addition to coverage for the Florida Workers' Compensation Act, where appropriate, coverage is to be included for the United States Longshoremen and Harbor Workers' Compensation Act, Federal Employees' Liability Act, and any other applicable Federal or State law.

(B) Subject to the restrictions of coverage found in the standard Workers' Compensation policy, there shall be no maximum limit on the amount of coverage for liability imposed by the Florida Workers' Compensation Act, the United States Longshoremen's and Harbor Workers' Compensation Act, or any other coverage customarily insured under Part One of the standard Workers' Compensation policy.

(C) The minimum amount of coverage under Part Two of the standard Workers' Compensation policy shall be:

\$500,000.00 (Each Accident)  
\$500,000.00 (Disease-Policy Limit)  
\$500,000.00 (Disease-Each Employee)

(2) Commercial General Liability.

(A) CONTRACTOR's insurance shall cover CONTRACTOR for those sources of liability which would be covered by the latest edition of the standard Commercial General Liability Coverage Form (ISO Form CG 00 01), as filed for use in the State of Florida by the Insurance Services Office, without the attachment of restrictive endorsements other than the elimination of Coverage C, Medical Payment, and the elimination of coverage for Fire Damage Legal Liability.

(B) The minimum limits to be maintained by CONTRACTOR (inclusive of any amounts provided by an Umbrella or Excess Policy) shall be as follows:

General Aggregate	Two Times (2x) the Each Occurrence Limit
Personal & Advertising	\$1,000,000.00
Injury Limit	
Each Occurrence Limit	\$1,000,000.00

(3) Professional Liability Insurance. CONTRACTOR shall carry Professional Insurance Liability insurance with limits of not less than One Million and No/100 Dollars (\$1,000,000.00).

(4) Business Auto Policy.

(A) CONTRACTOR's insurance shall cover CONTRACTOR for those sources of liability which would be covered by Part IV of the latest edition of the standard Business Auto Policy (ISO Form CA 00 01), as filed for use in the State of Florida by the Insurance Services Office, without the attachment of restrictive endorsements. Coverage shall include owned, non-owned and hired autos or any autos.

(B) The minimum limits to be maintained by CONTRACTOR (inclusive of any amounts provided by an Umbrella or Excess policy) shall be per-accident combined single limit for bodily injury liability and property damage liability. If the coverage is subject to an



aggregate, CONTRACTOR shall maintain separate aggregate limits of coverage applicable to claims arising out of or in connection with the work under this Agreement. The separate aggregate limits to be maintained by CONTRACTOR shall be a minimum of three times (3x) the per-accident limit required and shall apply separately to each policy year or part thereof.

(C) The minimum amount of coverage under the Business Auto Policy shall be:

Each Occurrence Bodily	\$1,000,000.00
Injury and Property Damage	
Liability Combined	

(d) Coverage. The insurance provided by CONTRACTOR pursuant to this Agreement shall apply on a primary and non-contributory basis, and any other insurance or self-insurance maintained by COUNTY or COUNTY's officials, officers, or employees shall be in excess of and not contributing to the insurance provided by or on behalf of CONTRACTOR.

(e) Occurrence Basis. The Workers' Compensation policy and the Commercial General Liability and the Umbrella policy required by this Agreement shall be provided on an occurrence rather than a claims-made basis. The Professional Liability insurance policy may be on an occurrence basis or claims-made basis. If a claims-made basis, the coverage must respond to all claims reported within three (3) years following the period for which coverage is required and which would have been covered had the coverage been on an occurrence basis.

(f) Obligations. Compliance with the foregoing insurance requirements shall not relieve CONTRACTOR, its employees, or its agents of liability from any obligation under a Section or any other portion of this Agreement.

### **Section 18. Dispute Resolution.**

(a) In the event of a dispute related to any performance or payment obligation arising under this Agreement, the parties agree to exhaust COUNTY dispute resolution procedures prior to

filing suit or otherwise pursuing legal remedies. COUNTY dispute resolution procedures for proper invoice and payment disputes are set forth in Section 22.15, "Prompt Payment Procedures," Seminole County Administrative Code. Contract claims include all controversies, except disputes addressed by the "Prompt Payment Procedures," arising under this Agreement within the dispute resolution procedures set forth in Section 3.5540, "Contract Claims," Seminole County Administrative Code.

(b) CONTRACTOR agrees that it will file no suit or otherwise pursue legal remedies based on facts or evidentiary materials that were not presented for consideration in COUNTY dispute resolution procedures set forth in subsection (a) above of which CONTRACTOR had knowledge and failed to present during COUNTY dispute resolution procedures.

(c) In the event that COUNTY dispute resolution procedures are exhausted and a suit is filed or legal remedies are otherwise pursued, the parties shall exercise best efforts to resolve disputes through voluntary mediation. Mediator selection and the procedures to be employed in voluntary mediation shall be mutually acceptable to the parties. Costs of voluntary mediation shall be shared equally among the parties participating in the mediation

**Section 19. Representatives of COUNTY and CONTRACTOR.**

(a) It is recognized that questions in the day to day conduct of performance pursuant to this Agreement will arise. COUNTY, upon request by CONTRACTOR, will designate and advise CONTRACTOR in writing of one or more of its employees to whom all communications pertaining to the day to day conduct of this Agreement shall be addressed. The designated representative shall have the authority to transmit instructions, receive information and interpret and define COUNTY's policy and decisions pertinent to the work covered by this Agreement.

(b) CONTRACTOR shall at all times during the normal work week designate or appoint one or more representatives who are authorized to act on behalf of CONTRACTOR and bind CONTRACTOR regarding all matters involving the conduct of the performance pursuant to this Agreement, and shall keep COUNTY continually and effectively advised of such designation.

**Section 20. All Prior Agreements Superseded.** This document incorporates and includes all prior negotiations, correspondence, conversations, agreements or understandings applicable to the matters contained herein and the parties agree that there are no commitments, agreements, or understandings concerning the subject matter of this Agreement that are not contained or referred to in this document. Accordingly, it is agreed that no deviation from the terms hereof shall be predicated upon any prior representations or agreements, whether oral or written.

**Section 21. Modifications, Amendments, or Alterations.** No modification, amendment, or alteration in the terms or conditions contained herein shall be effective unless contained in a written document executed with the same formality and of equal dignity herewith.

**Section 22. Independent Contractor.** It is agreed that nothing herein contained is intended or should be construed as in any manner creating or establishing a relationship of co-partners between the parties, or as constituting CONTRACTOR (including its officers, employees, and agents) as an agent, representative or employee of COUNTY for any purpose or in any manner whatsoever. CONTRACTOR is to be and shall remain forever an independent contractor with respect to all services performed under this Agreement.

**Section 23. Employee Status.** Persons employed by CONTRACTOR in the performance of services and functions pursuant to this Agreement shall have no claim to pension, workers' compensation, unemployment compensation, civil service or other employee rights or privileges granted to COUNTY's officers and employees either by operation of law or by COUNTY.

**Section 24. Services Not Provided For.** No claim for services furnished by CONTRACTOR not specifically provided for herein shall be honored by COUNTY.

**Section 25. Public Records Law.**

(a) CONTRACTOR acknowledges COUNTY's obligations under Article 1, Section 24, Florida Constitution and Chapter 119, Florida Statutes, to release public records to members of the public upon request. CONTRACTOR acknowledges that COUNTY is required to comply with Article 1, Section 24, Florida Constitution and Chapter 119, Florida Statutes, in the handling of the materials created under this Agreement and that said statute controls over the terms of this Agreement.

(b) CONTRACTOR specifically acknowledges its obligations to comply with Section 119.071, Florida Statutes, with regard to public records, and shall:

(1) keep and maintain public records that ordinarily and necessarily would be required by COUNTY in order to perform the services required under this Agreement;

(2) provide the public with access to public records on the same terms and conditions that COUNTY would provide the records and at a cost that does not exceed the cost provided in Chapter 119, Florida Statutes, or as otherwise provided by law;

(3) ensure that public records that are exempt or confidential and exempt from public records disclosure requirements are not disclosed, except as authorized by law; and

(4) meet all requirements for retaining public records and transfer, at no cost to the COUNTY, all public records in possession of CONTRACTOR upon termination of this Agreement and destroy any duplicate public records that are exempt or confidential and exempt from public records disclosure requirements. All records stored electronically must be provided

to COUNTY in a format that is compatible with the information technology system of COUNTY.

(c) Failure to comply with this Section shall be deemed a material breach of this Agreement, for which COUNTY may terminate this Agreement immediately upon written notice to CONTRACTOR.

**Section 26. Compliance with Laws and Regulations.** In providing all services pursuant to this Agreement, CONTRACTOR shall abide by all statutes, ordinances, rules, and regulations pertaining to or regulating the provisions of such services including those now in effect and hereafter adopted. Any violation of said statutes, ordinances, rules or regulations shall constitute a material breach of this Agreement and shall entitle COUNTY to terminate this Agreement immediately upon delivery of written notice of termination to CONTRACTOR.

**Section 27. Patents and Royalties.** Unless otherwise provided, CONTRACTOR shall be solely responsible for obtaining the right to use any patented or copyrighted materials in the performance of this Agreement. CONTRACTOR, without exception, shall indemnify and save harmless COUNTY and its employees from liability of any nature or kind, including costs and expenses for or on account of any copyrighted, patented, or unpatented invention, process, or article manufactured or supplied by CONTRACTOR. In the event of any claim against COUNTY of copyright or patent infringement, COUNTY shall promptly provide written notification to CONTRACTOR. If such a claim is made, CONTRACTOR shall use its best efforts to promptly purchase for COUNTY any infringing products or services or procure a license at no cost to COUNTY which will allow continued use of the service or product. If none of the alternatives are reasonably available, COUNTY agrees to return the article on request to



CONTRACTOR and receive reimbursement, if any, as may be determined by a court of competent jurisdiction.

**Section 28. Notices.** Whenever either party desires to give notice unto the other, it must be given by written notice, sent by registered or certified United States mail, return receipt requested, addressed to the party for whom it is intended at the place last specified. The place for giving of notice shall remain such until it shall have been changed by written notice in compliance with the provisions of this Section. For the present, the parties designate the following as the respective places for giving of notice, to-wit:

**For COUNTY:**

Seminole County Public Works Department  
1101 East First Street  
Sanford, Florida 32771

**For CONTRACTOR:**

The Middlesex Corporation  
One Spectacle Pond Road  
Littleton, Massachusetts 01460

**Section 29. Rights At Law Retained.** The rights and remedies of COUNTY provided for under this Agreement are in addition and supplemental to any other rights and remedies provided by law.

**IN WITNESS WHEREOF**, the parties hereto have made and executed this Agreement on the date below written for execution by COUNTY.

ATTEST:

  
Robert N. Jacobson, Secretary  
(CORPORATE SEAL)

THE MIDDLESEX CORPORATION

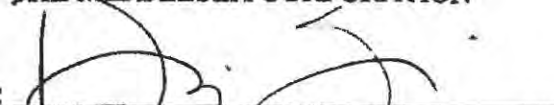
By:   
DAVID SOCCI, ~~Vice President~~  
Senior Vice/President Estimating  
Date: 11/21/2014

SEMINOLE COUNTY, FLORIDA

Sammy Roberts  
Witness  
Sammy Roberts  
Print Name

Denise Figueroa  
Witness  
Leticia Figueroa  
Print Name

By: [Signature]  
RAY HOOVER, Purchasing and  
Contracts Manager  
Date: 12/2/14

For the use and reliance  
Seminole County only.

As authorized for execution by the Board of  
County Commissioners at its 11/18,  
20 14, regular meeting.

Approved as to form and  
legal sufficiency.  
[Signature]

A-0059-15

County Attorney  
AEC:pk  
8/28/14 10:14/14  
P:\Users\Legal Secretary CSEVPurchasing 2014\IFB-602096\Middlesex.doc

Attachments:

- Exhibit A - Scope of Services and Cost Structure
- Exhibit B - Sample Release Order



106173397

**PERFORMANCE BOND**  
(\$500,000.00)

Seminole County Contract No. IFB-602096-14/BJC

**KNOW ALL MEN BY THESE PRESENTS** that:

The Middlesex Corporation  
(Name of CONTRACTOR)

One Spectacle Pond Road, Littleton, MA 01460  
(Address of CONTRACTOR)

CONTRACTOR's Telephone Number: 978-742-4400

a Corporation  
(Corporation, Partnership, or Individual)

hereinafter called Principal, and Travelers Casualty and Surety Company of America  
(Name of Surety)

One Tower Square, Hartford, CT 06183  
(Address of Surety)

Surety's Telephone Number: (800) 852-6677

hereinafter called Surety, are held and firmly bound unto SEMINOLE COUNTY, 1101 East First Street, Sanford, Florida 32771, hereinafter called COUNTY, in the sum of Five Hundred Thousand and 00/100 DOLLARS (\$500,000.00) in lawful money of the United States, for the payment of which sum well and truly to be made, we bind ourselves, successors, and assigns, jointly and severally, firmly by these presents. The sum shall not be less than five hundred thousand (\$500,000.00).

COUNTY's telephone number is (407) 665-7116. THE CONDITION OF THIS OBLIGATION is such that whereas, the Principal entered into a certain Agreement with COUNTY, dated the 2 day of December, 2014, a copy of which is hereto attached and made a part hereof for the Pavement Management Program in Seminole County.

Legal Description of Property: Seminole County

Pavement Management Program in Seminole County

General description of the Work: The CONTRACTOR is responsible for all labor, materials, equipment, coordination, and incidentals necessary for all Work related to the Pavement Management Program within Seminole County.

This Bond is being entered into to satisfy the requirements of Section 255.05, Florida Statutes, and the Agreement referenced above, as the same may be amended.

**NOW, THEREFORE,** the condition of this obligation is such that if Principal:

1. Promptly and faithfully performs its duties, all the covenants, terms, conditions, and agreements of said Agreement including, but not limited, to the guaranty period and the warranty provisions, in the time and manner prescribed in the Agreement; and
2. Pays COUNTY all liquidated damages, losses, damages, delay damages, expenses, costs, and attorneys fees, including costs and attorneys fees on appeal that COUNTY sustains resulting from any breach or default by Principal under the Agreement

then this bond is void; otherwise it shall remain in full force and effect.

The coverage of this Performance Bond is co-equal with each and every obligation of the Principal under the above-referenced Agreement and the Contract Documents of which the Agreement is a part except that the coverage of the Performance Bond is limited to 100 percent of the Contract Price.

In the event that the Principal shall fail to perform any of the terms, covenants, and conditions of the Agreement and the Contract Documents of which the Agreement is a part during the period in which this Performance Bond is in effect, the Surety shall remain liable to COUNTY for all such direct loss or damage (including reasonable attorneys fees and costs and attorneys fees and costs on appeal) resulting from any failure to perform, up to \$500,000.00 and for Indirect damages as determined by COUNTY up to an additional twenty percent (20%) over the adjusted amount.

In the event that the Surety fails to fulfill its obligations under this Performance Bond, then the Surety shall also indemnify and hold COUNTY harmless from any and all loss, damage, cost, and expense, including reasonable attorneys fees and costs for all trial and appellate proceedings, resulting from the Surety's failure to fulfill its obligations hereunder up to \$500,000.00.

The Surety stipulates and agrees that its obligation is to perform the Principal's Work under the Agreement under the Bond. The following preventative options by the Surety are encouraged; however, preventative options shall not be considered under the Bond: (i) Surety's financing of the Principal to keep Principal from defaulting under the Contract Documents; and (ii) Surety's offers to COUNTY to buy back the Bond. The Surety agrees that its obligation under the bond is to: (i) take over performance of the Principals' Work and be the completing Surety even if performance of the Principal's Work exceeds the adjusted Principals' Contract Price; or (ii) re-bid and re-let the Principals' Work to a completing contractor with Surety remaining liable for the completing contractor's performance of the Principal's Work and furnishing adequate funds to complete the Work. The Surety acknowledges that its cost of completion upon default by the

Principal may exceed the Contract Price. In any event, the Principal's Contract Time is of the essence and applicable delay damages are not waived by COUNTY.

The Surety, for value received, hereby stipulates and agrees that its obligations hereunder shall be direct and immediate and not conditional or contingent upon COUNTY's pursuit of its remedies against Principal, however, such obligation shall only arise upon a declaration of default of the Principal and shall remain in full force and effect notwithstanding (i) amendments or modifications to the Agreement entered into by COUNTY and Principal without Surety's knowledge or consent; and (ii) the discharge of Principal as a result of any proceeding initiated under the Bankruptcy Code of 1978, as the same maybe amended, or any similar state or federal law, or any limitations of the liability of Principal or its estate as a result of any such proceeding.

Any changes in or under the Agreement and Contract Documents and compliance or noncompliance with any formalities connected with the Agreement or the changes therein shall not affect Surety's obligations under this Bond and Surety hereby waives notice of any such changes. However, in the event Change Orders (unilateral or directive change orders and bilateral change orders) or other modifications to the Agreement and Contract Documents are executed exceeding 110 percent of the contract price, the Surety shall be notified by COUNTY of such increased by COUNTY, and the Principal shall be required to increase the sum of the Bond to be commensurate with the increased Contract Price.

The Performance Bond and the Payment Bond and the covered amounts of each are separate and distinct from each other.

This Performance Bond is intended to comply with the requirements of Section 255.05, Florida Statutes, as amended, and additionally, to provide contract rights more expansive than as required by statute.

***(End of Document – Signature Pages Follow)***

IN WITNESS WHEREOF, this instrument is executed this 21<sup>st</sup> day of November, 2014.

ATTEST:

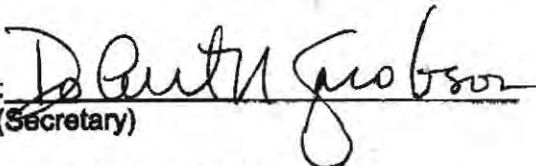
By:   
(Secretary)  
Name: Robert N. Jacobson  
(Typed or Printed)

PRINCIPAL/CONTRACTOR

The Middlesex Corporation  
By:   
(Officer)  
Name: David Socci  
(Typed or Printed)  
Title: Senior Vice President Estimating  
Address: One Spectacle Pond Road  
City, ST ZIP: Littleton, MA 01460

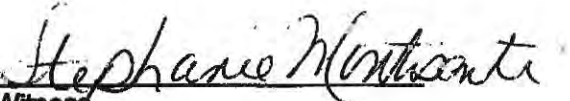
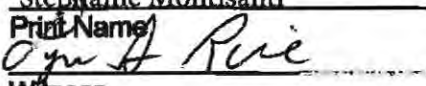
  
Witness  
Stephanie Montisanti  
Print Name  
  
Witness  
Lyn I. Rice  
Print Name

**(Surety Signature Page Follows)**

ATTEST:

By: [Signature]  
Vice President

Name: Mark Herendeen  
(Typed or Printed)

[Signature]  
Witness  
Jané Gilson  
Print Name  
Maria Chaves  
Witness  
Maria Chaves  
Print Name

SURETY

Travelers Casualty and Surety Company of America

By: [Signature]  
(Officer)

Name: Jean Correia  
(Typed or Printed) FL License # E145173

Title: Attorney-in-Fact  
Aon Risk Servies

Address: One Federal Street

City, ST ZIP: Boston, MA 02110

Countersigned by  
By: [Signature]  
Claudette Alexander Hunt  
FL Licensed Resident Agent # P134371

**NOTE:** Date of the Bond must not be prior to date of Agreement. If CONTRACTOR is a joint venture, all venturers shall execute the Bond. If CONTRACTOR is a Partnership, all partners shall execute the Bond.

**IMPORTANT:** Surety companies executing Bonds must appear on the Treasury Department's most current list (Circular 570, as amended) and be authorized to transact business in the State of Florida, unless otherwise specifically approved in writing by COUNTY.

All bonds shall be originals and issued or countersigned by a local producing agent who is authorized to operate in the State of Florida. Attorneys-in-fact who sign Bid Bonds or Performance/Payment Bonds must file with such bond a certified copy of their Power of Attorney to sign such Bond. Agents of Surety companies must list their name, address, and telephone number on all Bonds.





POWER OF ATTORNEY

Farmington Casualty Company
Fidelity and Guaranty Insurance Company
Fidelity and Guaranty Insurance Underwriters, Inc.
St. Paul Fire and Marine Insurance Company
St. Paul Guardian Insurance Company

St. Paul Mercury Insurance Company
Travelers Casualty and Surety Company
Travelers Casualty and Surety Company of America
United States Fidelity and Guaranty Company

Attorney-In Fact No. 226836

Certificate No. 005940818

KNOW ALL MEN BY THESE PRESENTS: That Farmington Casualty Company, St. Paul Fire and Marine Insurance Company, St. Paul Guardian Insurance Company, St. Paul Mercury Insurance Company, Travelers Casualty and Surety Company, Travelers Casualty and Surety Company of America, and United States Fidelity and Guaranty Company are corporations duly organized under the laws of the State of Connecticut, that Fidelity and Guaranty Insurance Company is a corporation duly organized under the laws of the State of Iowa, and that Fidelity and Guaranty Insurance Underwriters, Inc., is a corporation duly organized under the laws of the State of Wisconsin (herein collectively called the "Companies"), and that the Companies do hereby make, constitute and appoint

Mark P. Herendeen, Kevin A. White, Jean Correia, Maria Chaves, Theresan E. Rowedder, Jane Gilson, and Bryan Huft

of the City of Boston, State of Massachusetts, their true and lawful Attorney(s)-in-Fact, each in their separate capacity if more than one is named above, to sign, execute, seal and acknowledge any and all bonds, recognizances, conditional undertakings and other writings obligatory in the nature thereof on behalf of the Companies in their business of guaranteeing the fidelity of persons, guaranteeing the performance of contracts and executing or guaranteeing bonds and undertakings required or permitted in any actions or proceedings allowed by law.

IN WITNESS WHEREOF, the Companies have caused this instrument to be signed and their corporate seals to be hereto affixed, this 5th day of June, 2014.

Farmington Casualty Company
Fidelity and Guaranty Insurance Company
Fidelity and Guaranty Insurance Underwriters, Inc.
St. Paul Fire and Marine Insurance Company
St. Paul Guardian Insurance Company

St. Paul Mercury Insurance Company
Travelers Casualty and Surety Company
Travelers Casualty and Surety Company of America
United States Fidelity and Guaranty Company



State of Connecticut
City of Hartford ss.

By: [Signature]
Robert L. Raney, Senior Vice President

On this the 5th day of June, 2014, before me personally appeared Robert L. Raney, who acknowledged himself to be the Senior Vice President of Farmington Casualty Company, Fidelity and Guaranty Insurance Company, Fidelity and Guaranty Insurance Underwriters, Inc., St. Paul Fire and Marine Insurance Company, St. Paul Guardian Insurance Company, St. Paul Mercury Insurance Company, Travelers Casualty and Surety Company, Travelers Casualty and Surety Company of America, and United States Fidelity and Guaranty Company, and that he, as such, being authorized so to do, executed the foregoing instrument for the purposes therein contained by signing on behalf of the corporations by himself as a duly authorized officer.

In Witness Whereof, I hereunto set my hand and official seal.
My Commission expires the 30th day of June, 2016.



[Signature: Marie C. Tetreault]
Marie C. Tetreault, Notary Public



106173397

**PAYMENT BOND**

(\$500,000.00)

Seminole County Contract No. IFB-602096-14/BJC

**KNOW ALL MEN BY THESE PRESENTS** that:

The Middlesex Corporation  
(Name of CONTRACTOR)

One Spectacle Pond Road, Littleton, MA 01460  
(Address of CONTRACTOR)

CONTRACTOR's Telephone Number: 978-742-4400

a Corporation  
(Corporation, Partnership, or Individual)

hereinafter called Principal, and Travelers Casualty and Surety Company of America  
(Name of Surety)

One Tower Square, Hartford, CT 06183  
(Address of Surety)

Surety's Telephone Number: (800) 852-6677

hereinafter called Surety, are held and firmly bound unto SEMINOLE COUNTY, 1101 East First Street, Sanford, Florida 32771, hereinafter called COUNTY, in the sum of Five Hundred Thousand DOLLARS (\$500,000.00) in lawful money of the United States, for the payment of which sum well and truly to be made, we bind ourselves, successors, and assigns, jointly and severally, firmly by these presents.

COUNTY's telephone number is (407) 665-7116. THE CONDITION OF THIS OBLIGATION is such that whereas, the Principal entered into a certain Agreement with COUNTY, dated the 2 day of December, 2014, a copy of which is hereto attached and made a part hereof for the Pavement Management Program in Seminole County.

Legal Description of Property: Seminole County

Pavement Management Program in Seminole County

General description of the Work: The CONTRACTOR is responsible for all labor, materials, equipment, coordination, and incidentals necessary for all Work related to Pavement Management Program within Seminole County.

PAYMENT BOND

**NOW, THEREFORE**, the condition of this obligation is such that if Principal shall promptly make payments to all claimants as defined in Section 255.05(1), Florida Statutes, supplying Principal with labor, materials, or supplies, used directly or indirectly by Principal in the prosecution of the Work provided for in the Agreement, then this obligation shall be void; otherwise, it shall remain in full force and effect subject, however, to the following conditions:

1. This Bond is furnished for the purpose of complying with the requirements of Section 255.05, Florida Statutes, as same may be amended.
2. It is a specific condition of this Bond that a claimant's right of action on the Bond is limited to the provisions of Section 255.05, Florida Statutes, including, but not limited to, the one-year time limitation within which suits may be brought.
3. This Bond is conditioned that CONTRACTOR shall promptly make payments to all persons defined in Section 713.05, Florida Statutes, whose claims derive from the prosecution of the Work provided for in the Agreement.

Therefore, a claimant, except a laborer, who is not in privity with the CONTRACTOR shall, within forty-five (45) days after beginning to furnish labor, materials, or supplies for the prosecution of the Work, furnish CONTRACTOR with a notice that (s)he may look to the Bond for protection. A claimant who is not in privity with the CONTRACTOR and who has not received payment for his/her labor, materials, supplies, or rental equipment within ninety (90) days after final furnishing of the labor, services, materials, or equipment by claimant, deliver to CONTRACTOR and to the Surety written notice of the performance of the labor or delivery of the materials or supplies and of the nonpayment. No action for the labor, materials, or supplies may be instituted against CONTRACTOR or the Surety on the bond after one (1) year from the performance of the labor or completion of the delivery of the materials or supplies.

4. Any changes in or under the Agreement or Contract Documents and compliance or noncompliance with any formalities connected with the Agreement or the changes therein shall not affect Surety's obligations under this Bond and Surety hereby waives notice of any such changes. Further, Principal and Surety acknowledge that the sum of this Bond shall increase or decrease in accordance with the Change Orders (unilateral or directive change orders and bilateral change orders) or other modifications to the Agreement or Contract Documents.

5. The Performance Bond and the Payment Bond and the covered amounts of each are separate and distinct from each other. The Payment Bond shall be construed as a statutory Payment Bond under Section 255.05, Florida Statutes, and not as a common law bond.

IN WITNESS WHEREOF, this instrument is executed this 21<sup>st</sup> day of November, 20 14.

ATTEST:

PRINCIPAL/CONTRACTOR

By: *Robert N. Jacobson*  
(Secretary)

The Middlesex Corporation  
By: *David Socci*  
(Officer)

Name: Robert N. Jacobson  
(Typed or Printed)

Name: David Socci  
(Typed or Printed)

Title: Senior Vice President Estimating

Address: One Spectacle Pond Road

City, ST ZIP: Littleton, MA 01460

*Stephanie Montisanti*

Witness  
Stephanie Montisanti

Print Name  
*Lyn I. Rice*

Witness  
Lyn I. Rice  
Print Name

(Surety Signature Page Follows)

ATTEST

By: [Signature]  
Vice President

Name: Mark Herendeen  
(Typed or Printed)

[Signature]  
Witness  
Jane Gilson  
Print Name  
Maria Chaves  
Witness  
Maria Chaves  
Print Name

SURETY

Travelers Casualty and Surety Company of America

By: [Signature]  
(Officer)

Name: Jean Correia  
(Typed or Printed) FL License # E145173

Title: Attorney-in-Fact  
Aon Risk Services

Address: One Federal Street

City, ST ZIP Boston, MA 02110

Countersigned by  
By: [Signature]  
Claudette Alexander Hunt  
FL Licensed Resident Agent # P134371

**NOTE:** Date of the Bond must not be prior to date of Agreement. If CONTRACTOR is a joint venture, all venturers shall execute the Bond. If CONTRACTOR is a Partnership, all partners shall execute the Bond.

**IMPORTANT:** Surety companies executing Bonds must appear on the Treasury Department's most current list (Circular 570, as amended) and be authorized to transact business in the State of Florida, unless otherwise specifically approved in writing by COUNTY.

All bonds shall be originals and issued or countersigned by a local producing agent who is authorized to operate in the State of Florida. Attorneys-in-fact who sign Bid Bonds or Performance/Payment Bonds must file with such bond a certified copy of their Power of Attorney to sign such Bond. **Agents of Surety companies must list their name, address, and telephone number on all Bonds.**

Standard Form No. 34 (Revised 10-1-79) (Form 34) (10-1-79)

PAYMENT BOND



POWER OF ATTORNEY

Farmington Casualty Company
Fidelity and Guaranty Insurance Company
Fidelity and Guaranty Insurance Underwriters, Inc.
St. Paul Fire and Marine Insurance Company
St. Paul Guardian Insurance Company

St. Paul Mercury Insurance Company
Travelers Casualty and Surety Company
Travelers Casualty and Surety Company of America
United States Fidelity and Guaranty Company

Attorney-In Fact No. 226836

Certificate No. 005940817

KNOW ALL MEN BY THESE PRESENTS: That Farmington Casualty Company, St. Paul Fire and Marine Insurance Company, St. Paul Guardian Insurance Company, St. Paul Mercury Insurance Company, Travelers Casualty and Surety Company, Travelers Casualty and Surety Company of America, and United States Fidelity and Guaranty Company are corporations duly organized under the laws of the State of Connecticut, that Fidelity and Guaranty Insurance Company is a corporation duly organized under the laws of the State of Iowa, and that Fidelity and Guaranty Insurance Underwriters, Inc., is a corporation duly organized under the laws of the State of Wisconsin (herein collectively called the "Companies"), and that the Companies do hereby make, constitute and appoint

Mark P. Herendeen, Kevin A. White, Jean Correia, Maria Chaves, Theresan E. Rowedder, Jane Gilson, and Bryan Huft

of the City of Boston, State of Massachusetts, their true and lawful Attorney(s)-in-Fact, each in their separate capacity if more than one is named above, to sign, execute, seal and acknowledge any and all bonds, recognizances, conditional undertakings and other writings obligatory in the nature thereof on behalf of the Companies in their business of guaranteeing the fidelity of persons, guaranteeing the performance of contracts and executing or guaranteeing bonds and undertakings required or permitted in any actions or proceedings allowed by law.

IN WITNESS WHEREOF, the Companies have caused this instrument to be signed and their corporate seals to be hereto affixed, this 5th day of June, 2014.

Farmington Casualty Company
Fidelity and Guaranty Insurance Company
Fidelity and Guaranty Insurance Underwriters, Inc.
St. Paul Fire and Marine Insurance Company
St. Paul Guardian Insurance Company

St. Paul Mercury Insurance Company
Travelers Casualty and Surety Company
Travelers Casualty and Surety Company of America
United States Fidelity and Guaranty Company



State of Connecticut
City of Hartford ss.

By: [Signature]
Robert L. Raney, Senior Vice President

On this the 5th day of June, 2014, before me personally appeared Robert L. Raney, who acknowledged himself to be the Senior Vice President of Farmington Casualty Company, Fidelity and Guaranty Insurance Company, Fidelity and Guaranty Insurance Underwriters, Inc., St. Paul Fire and Marine Insurance Company, St. Paul Guardian Insurance Company, St. Paul Mercury Insurance Company, Travelers Casualty and Surety Company, Travelers Casualty and Surety Company of America, and United States Fidelity and Guaranty Company, and that he, as such, being authorized so to do, executed the foregoing instrument for the purposes therein contained by signing on behalf of the corporations by himself as a duly authorized officer.

In Witness Whereof, I hereunto set my hand and official seal. My Commission expires the 30th day of June, 2016.



[Signature]
Marie C. Tetreault, Notary Public



106173397

**MATERIAL AND WORKMANSHIP BOND**  
**(\$250,000.00)**  
Seminole County Contract No. IFB-602096-14/BJC

**KNOW ALL MEN BY THESE PRESENTS** that:

The Middlesex Corporation  
(Name of CONTRACTOR)

One Spectacle Pond Road, Littleton, MA 01460  
(Address of CONTRACTOR)

CONTRACTOR's Telephone Number: 978-742-4400

a Corporation  
(Corporation, Partnership, or Individual)

hereinafter called Principal, and Travelers Casualty and Surety Company of America  
(Name of Surety)

One Tower Square, Hartford CT 06183  
(Address of Surety)

Surety's Telephone Number: (800) 852-6677

hereinafter called Surety, are held and firmly bound unto SEMINOLE COUNTY, 1101 East First Street, Sanford, Florida 32771, hereinafter called COUNTY, in the sum of \$250,000.00 as adjusted under the Contract Documents in lawful money of the United States, for the payment of which sum well and truly to be made, we bind ourselves, successors, and assigns, jointly and severally, firmly by these presents.

COUNTY's telephone number is (407) 665-7116. THE CONDITION OF THIS OBLIGATION is such that whereas, the Principal entered into a certain Agreement with COUNTY, dated the 2 day of December, 2014, a copy of which is hereto attached and made a part hereof for the Pavement Management Program in Seminole County.

Principal is obligated to protect the County against any defects resulting from faulty Materials or Workmanship of said improvements for a period of two (2) years from the date of Final Completion under the Contract Documents.

The conditions of this obligation are such that if Principal shall promptly and faithfully protect the COUNTY against any Defects resulting from faulty Materials and Workmanship of the aforesaid improvements for a period of two (2) years from the date of Final Completion, then this obligation shall be null and void, otherwise it shall remain in full force and effect.

MATERIAL AND WORKMANSHIP BOND



The COUNTY shall notify the Principal in writing of any Defect for which the Principal is responsible and shall specify in said notice a reasonable period of time within which Principal shall have to correct said Defect.

The Surety unconditionally covenants and agrees that if the Principal fails to perform, within the time specified, the Surety, upon thirty (30) days written notice from COUNTY, or its authorized agent or officer, of the failure to perform will correct such Defect or Defects and pay the cost thereof, including, but not limited to engineering, legal and contingent cost. Should the Surety fail or refuse to correct said Defects, the COUNTY, in view of the public interest, health, safety, welfare and factors involved, shall have the right to resort to any and all legal remedies against the Principal and Surety and either, both at law and in equity, including specifically, specific performance to which the Principal and Surety unconditionally agree.

The Principal and Surety further jointly and severally agree that the COUNTY at its option, shall have the right to correct said Defects resulting from faulty Materials or Workmanship, or, pursuant to public advertisement and receipt of Bids, cause to be corrected any Defects or said Defects in case the Principal shall fail or refuse to do so, and in the event the COUNTY should exercise and give effect to such right, the Principal and the Surety shall jointly and severally hereunder reimburse the COUNTY the total cost thereof, including, but not limited to, engineering, legal and contingent cost, together with any damages either direct or consequent which may be sustained on account of the failure of the Principal to correct said defects.

***(End of Document – Signature Pages Follow)***

IN WITNESS WHEREOF, this instrument is executed this 21<sup>ST</sup> day of November, 2014.

ATTEST:

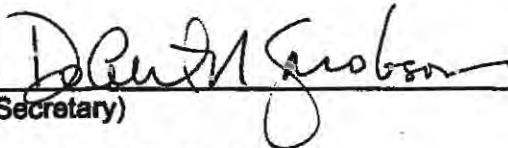
By:   
(Secretary)

Name: Robert N. Jacobson  
(Typed or Printed)

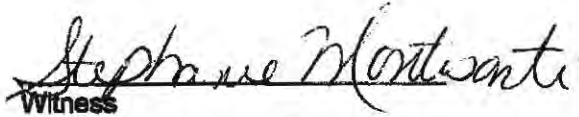
  
Witness

Stephanie Montisanti  
Print Name

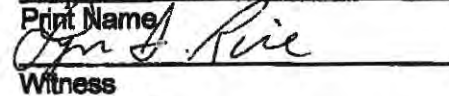
  
Witness

Lyn I. Rice  
Print Name

PRINCIPAL/CONTRACTOR

The Middlesex Corporation

By:   
(Officer)

Name: David Socci  
(Typed or Printed)

Title: Senior Vice President Estimating

Address: One Spectacle Pond Road

City, ST ZIP: Littleton, MA 01460

**(Surety Signature Page Follows)**

ATTEST:

SURETY

Travelers Casualty and Surety Company of America

By: [Signature]  
Vice President

By: [Signature]  
(Officer)

Name: Mark Herendeen  
(Typed or Printed)

Name: Jean Correia  
(Typed or Printed) FL LIC# 48145173

Title: Attorney-in-Fact

Aon Risk Services

Address: One Federal Street

City, ST ZIP: Boston, MA 02110

[Signature]

Witness  
Jane Gilson

Print Name  
Maria Chaves

Witness  
Maria Chaves

Print Name

Countersigned  
By: [Signature]

Claudette Alexander Hunt  
FL Licensed Resident Agent # P134371

**NOTE:** Date of the Bond must not be prior to date of Agreement. If CONTRACTOR is a joint venture, all venturers shall execute the Bond. If CONTRACTOR is a Partnership, all partners shall execute the Bond.

**IMPORTANT:** Surety companies executing Bonds must appear on the Treasury Department's most current list (Circular 570, as amended) and be authorized to transact business in the State of Florida, unless otherwise specifically approved in writing by COUNTY.

All bonds shall be originals and issued or countersigned by a local producing agent who is authorized to operate in the State of Florida. Attorneys-in-fact who sign Bid Bonds or Performance/Payment Bonds must file with such bond a certified copy of their Power of Attorney to sign such Bond. **Agents of Surety companies must list their name, address, and telephone number on all Bonds.**



POWER OF ATTORNEY

Farmington Casualty Company
Fidelity and Guaranty Insurance Company
Fidelity and Guaranty Insurance Underwriters, Inc.
St. Paul Fire and Marine Insurance Company
St. Paul Guardian Insurance Company

St. Paul Mercury Insurance Company
Travelers Casualty and Surety Company
Travelers Casualty and Surety Company of America
United States Fidelity and Guaranty Company

Attorney-In Fact No. 226836

Certificate No. 005940819

KNOW ALL MEN BY THESE PRESENTS: That Farmington Casualty Company, St. Paul Fire and Marine Insurance Company, St. Paul Guardian Insurance Company, St. Paul Mercury Insurance Company, Travelers Casualty and Surety Company, Travelers Casualty and Surety Company of America, and United States Fidelity and Guaranty Company are corporations duly organized under the laws of the State of Connecticut, that Fidelity and Guaranty Insurance Company is a corporation duly organized under the laws of the State of Iowa, and that Fidelity and Guaranty Insurance Underwriters, Inc., is a corporation duly organized under the laws of the State of Wisconsin (herein collectively called the "Companies"), and that the Companies do hereby make, constitute and appoint

Mark P. Herendeen, Kevin A. White, Jean Correia, Maria Chaves, Theresan E. Rowedder, Jane Gilson, and Bryan Huft

of the City of Boston, State of Massachusetts, their true and lawful Attorney(s)-in-Fact, each in their separate capacity if more than one is named above, to sign, execute, seal and acknowledge any and all bonds, recognizances, conditional undertakings and other writings obligatory in the nature thereof on behalf of the Companies in their business of guaranteeing the fidelity of persons, guaranteeing the performance of contracts and executing or guaranteeing bonds and undertakings required or permitted in any actions or proceedings allowed by law.

IN WITNESS WHEREOF, the Companies have caused this instrument to be signed and their corporate seals to be hereto affixed, this 5th day of June, 2014.

Farmington Casualty Company
Fidelity and Guaranty Insurance Company
Fidelity and Guaranty Insurance Underwriters, Inc.
St. Paul Fire and Marine Insurance Company
St. Paul Guardian Insurance Company

St. Paul Mercury Insurance Company
Travelers Casualty and Surety Company
Travelers Casualty and Surety Company of America
United States Fidelity and Guaranty Company



State of Connecticut
City of Hartford ss.

By: [Signature]
Robert L. Raney, Senior Vice President

On this the 5th day of June, 2014, before me personally appeared Robert L. Raney, who acknowledged himself to be the Senior Vice President of Farmington Casualty Company, Fidelity and Guaranty Insurance Company, Fidelity and Guaranty Insurance Underwriters, Inc., St. Paul Fire and Marine Insurance Company, St. Paul Guardian Insurance Company, St. Paul Mercury Insurance Company, Travelers Casualty and Surety Company, Travelers Casualty and Surety Company of America, and United States Fidelity and Guaranty Company, and that he, as such, being authorized so to do, executed the foregoing instrument for the purposes therein contained by signing on behalf of the corporations by himself as a duly authorized officer.

In Witness Whereof, I hereunto set my hand and official seal.
My Commission expires the 30th day of June, 2016.



[Signature: Marie C. Tetreault]
Marie C. Tetreault, Notary Public

## EXHIBIT A

### Part 1 Scope of Services

**Seminole County Specification Hierarchy:** All requirements set forth by this IFB contract shall adhere to the rules and conditions described in Seminole County's General Conditions for Road, Bridge & Utility Construction <http://www.seminolecountyfl.gov/fs/purchasing/pdf/800roads.pdf>. In addition, the attached Supplemental Specifications for this contract shall take priority to the County's General Condition as they are specific to the pay items and basis of payment for this contract. Bidder must be Florida Department of Transportation (FDOT) Prequalified in the following categories:

- Hot Plant-mixed Bituminous Courses
- Flexible Paving

#### **PAY ITEM NOTES**

##### **GROUP I**

###### **Superpave Asphaltic Concrete**

Included in the price of asphalt will be cost of all work and materials associated with the following items:

105 Quality Control; 300 Tack, Prime and Sand. (Section 334).

Basis of payment shall be under Items No.:

(334-1-) Superpave Asphaltic Concrete – per ton.

###### **Asphalt Concrete Friction Course**

Included in the price of asphalt will be cost of all work and materials associated with the following items:

105 Quality Control; 300 Tack, Prime and Sand. (Section 337)

Basis of payment shall be under Items No.:

(337-7-) Asphalt Concrete Friction Course – per ton.

###### **Bonded Asphalt Concrete Friction Course**

Included in the price of asphalt will be cost of all work and materials associated with the following items:

105 Quality Control; 300 Tack, Prime and Sand. (Section 337B)

Basis of payment shall be under Items No.:

(901-337-8) Bonded Asphalt Concrete Friction Course – per ton.

###### **Miscellaneous Asphalt Pavement**

Included in the price of asphalt will be cost of all work and materials associated with the following items:

105 Quality Control. (Spec Item No. 339)  
 Basis of payment shall be under Item No.:  
 (339-1) Miscellaneous Asphalt Concrete – per ton.

**Note:** 104 Erosion Control, 107 Litter Removal and Mowing, and 110 Clearing and Grubbing shall be included in the price bid for the top lift of asphalt including one of the items listed above.

## **GROUP II**

### **Prime and Tack Coats for Base Courses**

The pay item for Prime and Sand shall be a maintenance pay item only. Basis of payment shall be per square yard. The application of Prime and Sand or Tack on paving projects shall be included in the bid price of the asphalt under the 334 and 337 pay items. **(Section 916).**

Basis of payment shall be under Item No.:  
 (2-1) Prime and Sand – per square yard.

### **Asphalt Rubber Membrane Interlayer**

The pay item for Asphalt Rubber Interlayer includes cost of all work and materials associated with the Placement of the liquid rubber material, stone, equipment and all other incidentals required to place the rubber as specified under Section 341.

Basis of payment shall be under Items No.:  
 (341-70) Asphalt Rubber Membrane Interlayer – per square yard.

### **Open Graded Crack Relief Layer**

The pay item for Open Graded Crack Relief Layer includes cost of all work and materials associated with the placement of the mixture, equipment and all other incidentals required to place the mixture as specified under Section 340.

Basis of payment shall be under Items No.:  
 (906-340-1) Open Graded Crack Relief Layer- per square yard.

## **GROUP III**

### **Milling Existing Asphalt Pavement**

The basis of payment for milling shall be based on milling a single square yard at one inch depth. Each separate project bid shall specify the required mill depth that then may be multiplied by the depth in inches. The ultimate bid price for an individual project may not exceed the set contract rate for milling multiplied by the thickness in inches. The milling material under this pay item will become the property of the Contractor. **(Section 327).**

Basis of payment shall be under Item No.:  
 (327-70A) Milling Existing Asphalt Pavement - per square yard.

### **Milling Existing Asphalt Pavement (Yankee Lake)**

The basis of payment for milling shall be based on milling a single square yard at one inch depth. Each separate project bid shall specify the required mill depth that then may be



multiplied by the depth in inches. The ultimate bid price for an individual project may not exceed the set contract rate for milling multiplied by the thickness in inches. The milling material under this pay item will become the property of Seminole County and is to be delivered by the Contractor to 501 Yankee Lake Rd, Sanford. **(Section 327)**

Basis of payment shall be under Item No.:

(327-70B) Milling Existing Asphalt Pavement (Yankee Lake) - per square yard.

#### **Milling Existing Asphalt Pavement (Oviedo Yard)**

The basis of payment for milling shall be based on milling a single square yard at one inch depth. Each separate project bid shall specify the required mill depth that then may be multiplied by the depth in inches. The ultimate bid price for an individual project may not exceed the set contract rate for milling multiplied by the thickness in inches. The milling material under this pay item will become the property of Seminole County and is to be delivered by the Contractor to 1620 N County Rd 426, Oviedo. **(Section 327)**.

Basis of payment shall be under Item No.:

(327-70C) Milling Existing Asphalt Pavement (Oviedo Yard) - per square yard.

#### **Milling Existing Asphalt Pavement (Relocate)**

The basis of payment for milling shall be based on milling a single square yard at one inch depth. Each separate project bid shall specify the required mill depth that then may be multiplied by the depth in inches. The ultimate bid price for an individual project may not exceed the set contract rate for milling multiplied by the thickness in inches. The milling material under this pay item will become the property of Seminole County and is to be delivered by the Contractor to any location specified that is within 5 miles of the project limits. **(Section 327)**.

Basis of payment shall be under Item No.:

(327-70D) Milling Existing Asphalt Pavement (Relocate) - per square yard.

### **GROUP IV**

#### **Temporary Retroreflective Pavement Markers (RPM)**

Price for Temporary RPM shall include layout, materials and application of temporary RPM to supplement temporary lane lines. Payment shall be based on final measurements of RPM. **(Section 102)**.

Basis of payment shall be under Items No.:

(102-78) Temporary Retroreflective Pavement Markers – per each.

#### **Temporary Pavement Markings**

Price for Temporary Pavement Markings shall include layout, materials and application of paint and/or removable tape. Payment shall be based on final measurements of removable tape, painted stripes, or painted messages. **(Section 102; 710)**.

Basis of payment shall be under Items No.:

(102-911-2) Removable Tape (White/Black) - 6" – per foot.

(102-912-2) Removable Tape (Yellow) - 6" – per foot.

(710-11- ) Temporary Pavement Marking – Paint

## **GROUP V**

### **Liquidated Damages (LD):**

This item (LD) is a project specific item to be used with predetermined construction days to completion. All pertinent information, including identification of roadway type (major/minor) shall be included in the bid documents.

Time and weather shall be tracked and documented according to guidelines set by the FDOT Standard Specifications and amended in these contract documents.

General conditions 3.2 are amended to include Article 5.2 of the 2010 FDOT Standard Specifications regarding governing order of documents.

General conditions 6.2.3: Work hours of 7:00 AM to 6:00 PM can be superseded by the bid solicitation documents.

General conditions 6.42 and 6.43: Work suspensions, contractor vacations, and holidays are NOT included in the computation of contract time and will not be considered for time extensions.

General conditions 11.9.2; 12.1.1.1.3: No days have been included in the Construction time estimate for utility adjustments. Time extensions will be granted, on a day for day basis, for delays caused by utility adjustments by others only if no other work can be completed during such time. Time extensions may be granted, on a day for day basis, for delays caused by the effects of rains or other inclement weather conditions only after 5 (five) weather days and if no other work can be completed during such time. Time extension due to weather shall be reviewed and approved by the Engineer on a case-by-case basis.

It is noted that Sub-article 6-1.3 of the 2010 FDOT Standard Specifications shall apply to this contract and shall not be superseded by the General Conditions.

Payment for LD is set at a rate of (-) \$500.00 for each day for minor streets/roads.

Payment for LD is set at a rate of (-) \$1000.00 for each day for major roads.

A roadway is determined to be a minor street/road if it has a ADT less than 4000 vehicles per day; otherwise it is considered a major road. **(Section 6 and 11).**

Basis of payment shall be under Items No.:

(5-1) Liquidated Damages LD (For Major Roads) – per day.

(5-2) Liquidated Damages LD (For Minor Streets/Roads) – per day.

### **Mobilization Charge**

These items are intended to be used for two types of mobilization. Routine mobilization on projects shall include all labor, equipment, and material specified in Section 101. The price bid for routine mobilization shall not exceed 5% of the contract total. Emergency mobilization is also included to address special 24-hour emergency circumstances only. **(Section 101).**

Basis of payment shall be under Items No.:

(101-1) Mobilization Charge – each.

(101-2) Mobilization Charge for 24-hour emergency response – each.

### **Maintenance of Traffic (MOT)**

The price for MOT shall be on a per day basis and shall be for a time not exceeding the construction days specified in the project bid documents. Items included in this pay item will be the Arrow Board, required signs, channelizing devices, flaggers and other miscellaneous items typically required to maintain traffic.

No compensation will be made for time that exceeds the construction days specified in the bid. The price bid for MOT shall not exceed \$1500 per day. **(Section 102).**

Basis of payment shall be under: Item No. (102-1) Maintenance of Traffic – per day.

### **Traffic Control Officer**

The use of Traffic Control Officer is defined in Section 102-7, as approved by the Engineer/CCEI.

Payment shall be per hour (4 hour minimum) and based on the hours worked by the officer as recorded by the Engineer. **(Section 102).**

Basis of payment shall be under Item No.:

(102-14) Traffic Control Officer – per hour.

### **Portable Changeable Message Sign (PCMS)**

The use of PCMS shall be at the discretion and approval of the Engineer/CCEI. Payment shall be per each per day (ED) and based on the number of signs certified as installed/used on the project as recorded by the Engineer. **(Section 102).**

Basis of payment shall be under Item No.:

(102-99) Portable Changeable Message Sign – each day.

### **Flowable Fill**

This item is intended to fill voids, stabilize shoulders on roadway or other location that may require a method of permanently addressing areas of concern. Basis of payment shall be by the cubic yard (CY) and include all labor, equipment and materials. **(Section 121).**

Basis of payment shall be under Item No.:

(121-70) Flowable Fill – per cubic yard

### **Manhole and Water Valve Ring Adjustment**

The price of this item is for the installation of a manhole or water valve riser ring. **(Section 425).**

Basis of payment shall be under Items No.:

(425-6) Water Valve or similar cover Adjustment – each (EA).

(425-7) Manhole Ring Adjustment - each (EA).

## **GROUP VI**

### **FOB – Items**

Price for all items in this group will either be picked up at the asphalt plant by the County or delivered by the contractor where needed for Job Site items. Basis of payment will be by the unit of measure and contract rate for the individual pay item.

SP-4.75 Hot Mix Asphaltic Concrete can be substituted with S-I or S-III Marshall Mix with Seminole County Approval.

## **GROUP VII**

### **Type-B Stabilization**

The price for Stabilized Sub-grade includes all labor, equipment and materials that will be required to construct and test a 12" Stabilized Sub-grade as specified by **(Section 160)**.

Basis of payment shall be under Item No.:

(160-4) Type-B Stabilization – per square yard.

### **Base**

The price for road base shall include all labor, equipment and materials that will be required to construct road base Group (1, 6, & 9). Base groups 1 and 6 shall consist of limerock (LBR 100) only. Base group 9 shall consist of limerock (LBR 100) or 6" Type B-12.5, as specified by the bid documents. **(Section 285)**.

Basis of payment shall be under Items No.:

(285- ) Base Group - X – per square yard.

### **Shoulder Rework**

The price for this item includes the grading and mixing of roadway shoulders according to FDOT Design Standard Index 105. Sodding is not included in this item.

Basis of payment shall be under Item No.:

(577-70) Shoulder Rework - per square yard.

### **Regular Excavation**

The price for this item includes the grading excavation and removal of all materials. **(Section 120)**.

Basis of payment shall be under Items No.:

(120-1) Regular Excavation - per cubic yard.

### **Embankment**

The price for this item includes all materials required to build an embankment. **(Section 120)**.

Basis of payment shall be under Items No.:

(120-6) Embankment- per cubic yard.

### **NOTE:**

Performance Bond, Payment Bond and Materials and Workmanship Bonds will be required for this project.

**EXHIBIT A**

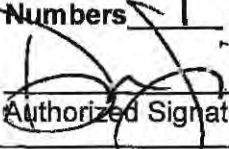
<b>SUBMIT BIDS TO:</b> Seminole County 1301 E. Second Street Sanford, Florida 32771 <b>Attn: PURCHASING &amp; CONTRACTS (PCD)</b>	<p align="center"><b>INVITATION FOR BID</b></p> <p align="center">And Bidder Acknowledgment</p>
Contact: Betsy J. Cohen, CPPB Procurement Supervisor 407-665-7112 - Phone 407-665-7956 - Fax bcohen@seminolecountyfl.gov	<p align="center"><b>IFB-602096-14/BJC</b></p> <p align="center"><b>PAVEMENT MANAGEMENT PROGRAM</b></p>
<p align="center"><b><u>Bid Due Date</u></b></p> <p align="center"><b>Date: October 1, 2014</b>  <b>Time: 2:00 PM</b>                  (Eastern Standard Time)</p> <p align="center"><b><u>Location of Public Opening:</u></b>  <b>Purchasing &amp; Contracts Division, Conference Room</b>  <b>1301 E. Second Street, Sanford, FL 32771</b></p>	
Proposer Name: The Middlesex Corporation	Federal Employer ID Number: 04-2534615
Mailing Address: One Spectacle Pond Road	If returning as a "No Submittal", state reason (if so, return only this page):
City, State, Zip: Littleton, MA 01460	
Type of Entity (Circle one): <u>Corporation</u> Partnership Proprietorship Joint Venture Incorporated in the State of: <u>Massachusetts</u> List of Principals: <u>Please See Attachment "A"</u>	The undersigned Bidder hereby acknowledges receipt of Addenda Numbers <u>1</u> through <u>1</u> :  Authorized Signature (Manual) <u>9/24/14</u> Date
Email Address: dsocci@middlesexco.com	Typed Name: David Socci
Telephone Number: 978-742-4400	Title: Senior Vice President Estimating
Fax Number: 978-742-4434	Date: <u>9/24/14</u>

**THIS FORM MUST BE COMPLETED AND RETURNED WITH WRITTEN BID**

The Bidder is expected to completely analyze the information contained in this Invitation for Bid (IFB) as guidance for the preparation of their written submittal. The Bidder's written bid should be specific, detailed, and complete in order to clearly and fully demonstrate the Bidder's understanding of the requested work and/or delivery requirements.



**Part 4  
Price Submittal**

**IFB-602096-14/BJC – Pavement Management Program**

Name of Bidder: The Middlesex Corporation

Mailing Address: One Spectacle Pond Road

Street Address: Same as Above

City/State/Zip: Littleton, MA 01460

Phone Number: ( 978 ) 742-4400 FAX Number: ( 978 ) 742-4434

E-Mail Address: dsocci@middlesexco.com

Pursuant to and in compliance with the IFB Documents, the undersigned Bidder agrees to provide and furnish any and all of the labor, material, tools, equipment, incidentals and transportation services necessary to complete all of the Work required in connection with the Bid Documents for the amount hereinafter set forth. Bidder declares that the only persons or parties interested in this bid as principals are those named herein; that this bid is made without collusion with any person, firm or corporation; and he proposes and agrees, if the bid is accepted, that he/she will accept to enter into an Agreement with the COUNTY in the form set forth in the Purchase Order and solicitation Documents. The cost of the units shall include all costs, including but not limited to:

- General Administrative Overhead, fringe and benefits and profit, all documentation required for operation, delivery/transportation of unit(s) to the County's delivery address, indirect costs, i.e., insurance, etc., indirect labor costs

Group I includes Asphalt	Subtotal: \$ <u>20,610,200.<sup>00</sup></u>
Group II is "Sand and Seal in-place"	Subtotal: \$ <u>266,500.<sup>00</sup></u>
Group III is "Milling"	Subtotal: \$ <u>289,000.<sup>00</sup></u>
Group IV is "Striping"	Subtotal: \$ <u>79,600.<sup>00</sup></u>
Group V is "Miscellaneous Items"	Subtotal: \$ <u>385,000.<sup>00</sup></u>
Group VI Asphalt Materials (materials only)	Subtotal: \$ <u>398,800.<sup>00</sup></u>
Group VII Earthwork	Subtotal: \$ <u>832,000.<sup>00</sup></u>
<b>TOTAL BID:</b>	<b>\$ <u>22,861,100.<sup>00</sup></u></b>
Performance/Payment/Material-Workmanship Bonds Costs: \$	<u>197,000.<sup>00</sup></u>
(Do not include in Unit Costs)	





IFB-602096-14/BJC - Pavement Management Program

PART A - ROAD CONSTRUCTION PRODUCTS AND RELATED MATERIALS IN-PLACE SERVICES

Labor and Materials

Group I: Asphalt Concrete, Surface Treatment and Friction Course in-place

Pay Item No.	Description	0-50 Tons/Job	51-399 Tons/Job	400 - 1999 Tons/Job	2000 - 3999 Tons/Job	4000 Tons/Job and Over	Sum of Extended Cost
334-1-12	Superpave Asphaltic Concrete Traffic Level B	Estimated 100 Tons \$ 300. <sup>00</sup> /ton Total: \$ 30,000. <sup>00</sup>	Estimated 500 Tons \$ 150. <sup>00</sup> /ton Total: \$ 75,000. <sup>00</sup>	Estimated 2400 Tons \$ 94. <sup>00</sup> /ton Total: \$ 225,600. <sup>00</sup>	Estimated 5000 Tons \$ 88. <sup>00</sup> /ton Total: \$ 440,000. <sup>00</sup>	Estimated 8000 Tons \$ 83. <sup>00</sup> /ton Total: \$ 704,000. <sup>00</sup>	\$ 1,474,600. <sup>00</sup>
334-1-13	Superpave Asphaltic Concrete Traffic Level C	Estimated 150 Tons \$ 30. <sup>00</sup> /ton Total: \$ 45,000. <sup>00</sup>	Estimated 600 Tons \$ 150. <sup>00</sup> /ton Total: \$ 90,000. <sup>00</sup>	Estimated 5000 Tons \$ 94. <sup>00</sup> /ton Total: \$ 470,000. <sup>00</sup>	Estimated 7000 Tons \$ 90. <sup>00</sup> /ton Total: \$ 630,000. <sup>00</sup>	Estimated 20000 Tons \$ 90. <sup>00</sup> /ton Total: \$ 1,800,000. <sup>00</sup>	\$ 3,035,000. <sup>00</sup>
334-1-22	Superpave Asphaltic Concrete Traffic Level B (PG 76-22) PMA	Estimated 100 Tons \$ 350. <sup>00</sup> /ton Total: \$ 35,000. <sup>00</sup>	Estimated 400 Tons \$ 170. <sup>00</sup> /ton Total: \$ 68,000. <sup>00</sup>	Estimated 3000 Tons \$ 115. <sup>00</sup> /ton Total: \$ 345,000. <sup>00</sup>	Estimated 5000 Tons \$ 110. <sup>00</sup> /ton Total: \$ 550,000. <sup>00</sup>	Estimated 9000 Tons \$ 110. <sup>00</sup> /ton Total: \$ 990,000. <sup>00</sup>	\$ 1,988,000. <sup>00</sup>
334-1-23	Superpave Asphaltic Concrete Traffic Level C (PG 76-22) PMA	Estimated 100 Tons \$ 350. <sup>00</sup> /ton Total: \$ 35,000. <sup>00</sup>	Estimated 800 Tons \$ 170. <sup>00</sup> /ton Total: \$ 136,000. <sup>00</sup>	Estimated 5000 Tons \$ 115. <sup>00</sup> /ton Total: \$ 575,000. <sup>00</sup>	Estimated 7300 Tons \$ 112. <sup>00</sup> /ton Total: \$ 817,600. <sup>00</sup>	Estimated 15000 Tons \$ 112. <sup>50</sup> /ton Total: \$ 1,687,500. <sup>00</sup>	\$ 3,217,100. <sup>00</sup>
337-7-40	Asphalt Concrete Friction Course FC-9.5 Traffic Level B	Estimated 100 Tons \$ 400. <sup>00</sup> /ton Total: \$ 40,000. <sup>00</sup>	Estimated 300 Tons \$ 200. <sup>00</sup> /ton Total: \$ 60,000. <sup>00</sup>	Estimated 3000 Tons \$ 140. <sup>00</sup> /ton Total: \$ 420,000. <sup>00</sup>	Estimated 5000 Tons \$ 130. <sup>00</sup> /ton Total: \$ 650,000. <sup>00</sup>	Estimated 8000 Tons \$ 130. <sup>00</sup> /ton Total: \$ 1,040,000. <sup>00</sup>	\$ 2,210,000. <sup>00</sup>
337-7-41	Asphalt Concrete Friction Course FC-12.5 Traffic Level B	Estimated 150 Tons \$ 350. <sup>00</sup> /ton Total: \$ 52,500. <sup>00</sup>	Estimated 700 Tons \$ 175. <sup>00</sup> /ton Total: \$ 122,500. <sup>00</sup>	Estimated 6000 Tons \$ 125. <sup>00</sup> /ton Total: \$ 750,000. <sup>00</sup>	Estimated 8000 Tons \$ 115. <sup>00</sup> /ton Total: \$ 920,000. <sup>00</sup>	Estimated 15000 Tons \$ 115. <sup>00</sup> /ton Total: \$ 1,725,000. <sup>00</sup>	\$ 3,570,000. <sup>00</sup>
337-7-42	Asphalt Concrete Friction Course FC-9.5 Traffic Level C	Estimated 80 Tons \$ 400. <sup>00</sup> /ton Total: \$ 32,000. <sup>00</sup>	Estimated 300 Tons \$ 200. <sup>00</sup> /ton Total: \$ 60,000. <sup>00</sup>	Estimated 1500 Tons \$ 140. <sup>00</sup> /ton Total: \$ 210,000. <sup>00</sup>	Estimated 3500 Tons \$ 130. <sup>00</sup> /ton Total: \$ 455,000. <sup>00</sup>	Estimated 6000 Tons \$ 130. <sup>00</sup> /ton Total: \$ 780,000. <sup>00</sup>	\$ 1,537,000. <sup>00</sup>

Company Name: The Middlesex Corporation

Addendum #1 Received 9/24/14



IFB-602096-14/BJC - Pavement Management Program

**PART A - ROAD CONSTRUCTION PRODUCTS AND RELATED MATERIALS IN-PLACE SERVICES**

Labor and Materials

**Group I: Asphalt Concrete, Surface Treatment and Friction Course in-place**

Pay Item No.	Description	0-50 Tons/Job	51-399 Tons/Job	400 - 1999 Tons/Job	2000 - 3999 Tons/Job	4000 Tons/Job and Over	Sum of Extended Cost
337-7-43	Asphalt Concrete Friction Course FC-12.5 Traffic Level C	Estimated 80 Tons \$ 350. <sup>00</sup> /ton Total: \$ 28,000. <sup>00</sup>	Estimated 350 Tons \$ 175. <sup>00</sup> /ton Total: \$ 61,250. <sup>00</sup>	Estimated 3000 Tons \$ 125. <sup>00</sup> /ton Total: \$ 375,000. <sup>00</sup>	Estimated 3500 Tons \$ 115. <sup>00</sup> /ton Total: \$ 402,500. <sup>00</sup>	Estimated 8000 Tons \$ 115. <sup>00</sup> /ton Total: \$ 920,000. <sup>00</sup>	\$ 1,786,750. <sup>00</sup>
337-7-45	Asphalt Concrete Friction Course FC-12.5 Traffic Level D	Estimated 80 Tons \$ 350. <sup>00</sup> /ton Total: \$ 28,000. <sup>00</sup>	Estimated 350 Tons \$ 175. <sup>00</sup> /ton Total: \$ 61,250. <sup>00</sup>	Estimated 3000 Tons \$ 130. <sup>00</sup> /ton Total: \$ 390,000. <sup>00</sup>	Estimated 3500 Tons \$ 120. <sup>00</sup> /ton Total: \$ 420,000. <sup>00</sup>	Estimated 6000 Tons \$ 120. <sup>00</sup> /ton Total: \$ 720,000. <sup>00</sup>	\$ 1,619,250. <sup>00</sup>
901-337-8	Bonded Asphalt Concrete Friction Course FC-5 (PG 76-22) Section 337B	Estimated 160 Tons \$ _____ /ton Total: \$ _____	Estimated 450 Tons \$ _____ /ton Total: \$ _____	Estimated 2400 Tons \$ _____ /ton Total: \$ _____	Estimated 3500 Tons \$ _____ /ton Total: \$ _____	Estimated 8000 Tons \$ _____ /ton Total: \$ _____	\$ _____
339-1	Miscellaneous Asphalt Pavement	Estimated 200 Tons \$ 300. <sup>00</sup> /ton Total: \$ 60,000. <sup>00</sup>	Estimated 500 Tons \$ 225. <sup>00</sup> /ton Total: \$ 112,500. <sup>00</sup>				\$ 172,500. <sup>00</sup>
<b>TOTAL FOR GROUP I</b>							<b>\$ 20,610,200.<sup>00</sup></b>



IFB-602096-14/BJC - Pavement Management Program

Group II: Sand and Seal in-place

Pay Item No.	Description	0-999 SY / Per Job	1000-1999 SY / Per Job	2000-2999 SY / Per Job	3000 SY and Over / Per Job	Sum of Extended Cost
2-1	Prime and Sand  (Section 916)	Estimated 500 SY: \$ 4.00 /SY Total: \$ 2,000.00	Estimated 1000 SY: \$ 2.00 /SY Total: \$ 2,000.00	Estimated 2000 SY: \$ 1.00 /SY Total: \$ 2,000.00	Estimated 3000 SY: \$ 0.50 /SY Total: \$ 1,500.00	\$ 7,500.00
341-70	Asphalt Rubber Membrane Interlayer (ARMI)  (Section 341)	Estimated 500 SY: \$ 25.00 /SY Total: \$ 12,500.00	Estimated 1000 SY: \$ 15.00 /SY Total: \$ 15,000.00	Estimated 2000 SY: \$ 11.00 /SY Total: \$ 22,000.00	Estimated 3000 SY: \$ 10.00 /SY Total: \$ 30,000.00	\$ 79,500.00
906-340-1	Open Graded Crack Relief Layer  (Dev Spec Section 340)	Estimated 500 SY: \$ 25.00 /SY Total: \$ 12,500.00	Estimated 2000 SY: \$ 14.00 /SY Total: \$ 28,000.00	Estimated 5000 SY: \$ 11.00 /SY Total: \$ 55,000.00	Estimated 8000 SY: \$ 10.50 /SY Total: \$ 84,000.00	\$ 179,500.00
TOTAL FOR GROUP II						\$ 266,500.00

Company Name: The Middlesex Corporation



## IFB-602096-14/BJC - Pavement Management Program

## Group III: Milling existing asphalt pavement in-place

Pay Item No.	Description	0-999 SY / Per Job	1000-1999 SY / Per Job	2000-2999 SY / Per Job	3000 SY and Over / Per Job	Sum of Extended Cost
327-70A	Milling Existing Asphalt Pavement (Milled Material becomes property of Contractor)	Estimated 1000 SY/inch: \$ 10. <sup>00</sup> /SY Total: \$ 10,000. <sup>00</sup>	Estimated 2000 SY/inch: \$ 6. <sup>00</sup> /SY Total: \$ 12,000. <sup>00</sup>	Estimated 8000 SY/inch: \$ 2.50 /SY Total: \$ 20,000. <sup>00</sup>	Estimated 20,000 SY/inch \$ 2.50 /SY Total: \$ 50,000. <sup>00</sup>	\$ 92,000. <sup>00</sup>
327-70B	Milling Existing Asphalt Pavement (Yankee Lake) Material delivered to Yankee Lake Yard in Sanford at: 501 Yankee Lake Rd. Sanford FL, 32771	Estimated 1000 SY/inch: \$ 12. <sup>00</sup> /SY Total: \$ 12,000. <sup>00</sup>	Estimated 2000 SY/inch: \$ 6.50 /SY Total: \$ 13,000. <sup>00</sup>	Estimated 6000 SY/inch: \$ 3. <sup>00</sup> /SY Total: \$ 18,000. <sup>00</sup>	Estimated 10,000 SY/inch \$ 2.50 /SY Total: \$ 25,000. <sup>00</sup>	\$ 68,000. <sup>00</sup>
327-70C	Milling Existing Asphalt Pavement (Oviedo Yard) Material delivered to County Yard in Oviedo at: 1620 N. County Rd 426 Oviedo, FL 32765	Estimated 1000 SY/inch: \$ 12. <sup>00</sup> /SY Total: \$ 12,000. <sup>00</sup>	Estimated 2000 SY/inch: \$ 6.50 /SY Total: \$ 13,000. <sup>00</sup>	Estimated 6000 SY/inch: \$ 3. <sup>00</sup> /SY Total: \$ 18,000. <sup>00</sup>	Estimated 10,000 SY/inch \$ 2.50 /SY Total: \$ 25,000. <sup>00</sup>	\$ 68,000. <sup>00</sup>
327-70D	Milling Existing Asphalt Pavement (Relocate) Milled Material delivered to location within 5 miles of project limits	Estimated 1000 SY/inch: \$ 10. <sup>00</sup> /SY Total: \$ 10,000. <sup>00</sup>	Estimated 2000 SY/inch: \$ 6. <sup>00</sup> /SY Total: \$ 12,000. <sup>00</sup>	Estimated 6000 SY/inch: \$ 2.75 /SY Total: \$ 16,500. <sup>00</sup>	Estimated 10,000 SY/inch \$ 2.25 /SY Total: \$ 22,500. <sup>00</sup>	\$ 61,000. <sup>00</sup>
<b>TOTAL FOR GROUP III</b>						<b>\$ 289,000.<sup>00</sup></b>

Company Name: The Middlesex Corporation



## IFB-602096-14/BJC - Pavement Management Program

## Group IV: Temporary Pavement Marking in-place

Pay Item No.	Description	Quantity	Sum of Extended Cost
102-78	Temporary Retroreflective Pavement Markers	Estimated 2500 EA: \$ <u>5.00</u> /Each	\$ 12,500.00
102-911-2	Removable Tape (White/Black) - 6"	Estimated 5000 LF: \$ <u>2.50</u> /LF	\$ 12,500.00
102-912-2	Removable Tape (Yellow) - 6"	Estimated 5000 LF: \$ <u>2.50</u> /LF	\$ 12,500.00
710-11-111	Temporary Pavement Marking - Paint - White Solid Stripe 6"	Estimated 10,000 LF: \$ <u>0.50</u> /LF	\$ 5,000.00
710-11-141	Temporary Pavement Marking - Paint - White Skip Stripe 6"	Estimated 3000 LF: \$ <u>1.00</u> /LF	\$ 3,000.00
710-11-221	Temporary Pavement Marking - Paint - Yellow Solid Stripe 6"	Estimated 15,000 LF: \$ <u>0.50</u> /LF	\$ 7,500.00
710-11-241	Temporary Pavement Marking - Paint - Yellow Skip Stripe 6"	Estimated 5000 LF: \$ <u>1.00</u> /LF	\$ 5,000.00
710-11-123	Temporary Pavement Marking - Paint - 12" White	Estimated 5000 LF: \$ <u>0.75</u> /LF	\$ 3,750.00
710-11-125	Temporary Pavement Marking - Paint - Stop Bar 24" White	Estimated 3000 LF: \$ <u>1.50</u> /LF	\$ 4,500.00
710-11-910	Temporary Pavement Marking - Paint - School Zone	Estimated 24 EA: \$ <u>200.00</u> /Each	\$ 4,800.00
710-11-920	Temporary Pavement Marking - Paint - Railroad Crossing	Estimated 24 EA: \$ <u>200.00</u> /Each	\$ 4,800.00
710-11-170	Temporary Pavement Marking - Paint - White Arrows	Estimated 50 EA: \$ <u>75.00</u> /Each	\$ 3,750.00
TOTAL FOR GROUP IV			\$ 79,600.00

Company Name: The Middlesex Corporation





## IFB-602096-14/BJC - Pavement Management Program

## Group V: Miscellaneous Items, Mobilization, MOT, Speed humps, Utility Adjustment

Pay Item No.	Description	Quantity	Sum of Extended Cost
5-1	Liquidated Damages LD (For Major Roads) (For use only with projects having a defined time to completion as advertised in the individual bid for that project.) (Section 6 and 11)	Estimated 1 each -1,000.00 ED Total -\$1,000.00	Do not include this in bid total
5-2	Liquidated Damages LD (For Minor Streets/Roads) (For use only with projects having a defined time to completion as advertised in the individual bid for that project.) (Section 6 and 11)	Estimated 1 each -\$500.00 ED Total -\$500.00	Do not include this in bid total
101-1	Mobilization Charge (not to exceed 5% of contract total) Includes labor/equipment/materials	Estimated 30 each day \$ 35,000.00 /day Total \$ 1,140,000.00	Do not include this in bid total
101-2	Mobilization Charge for 24-hour emergency response. Includes labor/equipment/materials	Estimated 30 each day \$ 3,500.00 /day	\$ 105,000.00
102-1	Maintenance of Traffic Includes labor/equipment/materials (not to exceed \$1500 per day)	Estimated 30 ED \$ 1,500.00 /day	\$ 45,000.00
102-14	Traffic Control Officer	Estimated 100 HR \$ 75.00 /Hours	\$ 7,500.00
102-99	Portable Changeable Message Sign	Estimated 1000 ED \$ 35.00 /day	\$ 35,000.00
121-70	Flowable Fill Includes labor/equipment/materials	Estimated 1000 CY \$ 185.00 /CY	\$ 185,000.00
425-6	Water Valve or similar cover adjustment	Estimated 25 each: \$ 100.00 /Each	\$ 2,500.00
425-7	Manhole Ring Adjustment	Estimated 25 each: \$ 200.00 /Each	\$ 5,000.00
TOTAL FOR GROUP V			\$ 385,000.00

Company Name: The Middlesex Corporation





IFB-602096-14/BJC - Pavement Management Program

FOB Items > Materials Only

**Group VI: Asphalt Materials (materials only)**

Pay Item No.	Description	FOB Plant	FOB Job Site	Sum of Extended Cost
6-1	SP-12.5 Hot Mix Asphaltic Concrete  (Section 334)	Estimated 1000 Tons \$ 52.00 /Ton Total: \$ 52,000.00	Estimated 200 Tons \$ 62.50 /Ton Total: \$ 12,500.00	\$ 64,500.00
6-2	SP-9.5 Hot Mix Asphaltic Concrete  (Section 334)	Estimated 1000 Tons \$ 55.00 /Ton Total: \$ 55,000.00	Estimated 200 Tons \$ 64.00 /Ton Total: \$ 12,800.00	\$ 67,800.00
6-3	SP-4.75 Hot Mix Asphaltic Concrete  (Section 334)	Estimated 1000 Tons \$ 70.00 /Ton Total: \$ 70,000.00	Estimated 1000 Tons \$ 85.00 /Ton Total: \$ 85,000.00	\$ 155,000.00
6-4	Superpave Asphalt Concrete FC-12.5 > Granite Aggregate (with PG 76-22) (Section 337)	Estimated 200 Tons \$ 90.00 /Ton Total: \$ 18,000.00	Estimated 200 Tons \$ 105.00 /Ton Total: \$ 21,000.00	\$ 39,000.00
6-5	Superpave Asphalt Concrete FC-9.5 > Granite Aggregate (with PG 76-22) (Section 337)	Estimated 200 Tons \$ 90.00 /Ton Total: \$ 18,000.00	Estimated 200 Tons \$ 105.00 /Ton Total: \$ 21,000.00	\$ 39,000.00
6-6	Asphalt Milling Material	Estimated 500 Tons \$ 25.00 /Ton Total: \$ 12,500.00	Estimated 500 Tons \$ 35.00 /Ton Total: \$ 17,500.00	\$ 30,000.00
6-7	Tack Type RS-1/RS-2	Estimated 1000 Gallons \$ 3.50 /Gal Total: \$ 3,500.00		\$ 3,500.00
<b>TOTAL FOR GROUP VI</b>				<b>\$ 348,800.00</b>

Asphalt can be S-I or S-III Marshall Mix at Seminole County Approval.

Company Name: The Middlesex Corporation



IFB-602096-14/BJC - Pavement Management Program

Group VII: Earthwork

Pay Item No.	Description	0-1499 SY	1500 SY and Over			Sum of Extended Cost
160-4	Type B Stabilization - 12" LBR 40	Estimated 1000 SY: \$ 25.00 /SY Total: \$ 25,000.00	Estimated 3000 SY: \$ 18.50 /SY Total: \$ 55,500.00			\$ 80,500.00
285-701	Base Group 01 (Limerock LBR 100)	Estimated 1000 SY: \$ 25.50 /SY Total: \$ 25,500.00	Estimated 1500 SY: \$ 18.00 /SY Total: \$ 27,000.00			\$ 52,500.00
285-706	Base Group 06 (Limerock LBR 100)	Estimated 1000 SY: \$ 30.00 /SY Total: \$ 30,000.00	Estimated 1500 SY: \$ 22.00 /SY Total: \$ 33,000.00			\$ 63,000.00
285-709-A	Base Group 09 (Limerock LBR 100)	Estimated 1000 SY: \$ 32.00 /SY Total: \$ 32,000.00	Estimated 3000 SY: \$ 26.00 /SY Total: \$ 78,000.00			\$ 110,000.00
285-709-B	Base Group 09 (6" Type B-12.5)	Estimated 1000 SY: \$ 65.00 /SY Total: \$ 65,000.00	Estimated 4000 SY: \$ 39.00 /SY Total: \$ 156,000.00			\$ 221,000.00
577-70	Shoulder Rework	Estimated 1000 SY: \$ 20.00 /SY Total: \$ 20,000.00	Estimated 3000 SY: \$ 12.50 /SY Total: \$ 37,500.00			\$ 57,500.00
Pay Item No.	Description	0-1000 CY	1001 CY and Over			Sum of Extended Cost
120-1	Regular Excavation	Estimated 1000 CY: \$ 35.00 /CY Total: \$ 35,000.00	Estimated 2500 CY: \$ 25.00 /CY Total: \$ 62,500.00			\$ 97,500.00
120-6	Embankment	Estimated 1000 CY: \$ 55.00 /CY Total: \$ 55,000.00	Estimated 2500 CY: \$ 38.00 /CY Total: \$ 95,000.00			\$ 150,000.00
Company Name: <u>The Middlesex Corporation</u>						TOTAL FOR GROUP VII \$ 832,000.00

**TAX EXEMPTION NUMBERS**

FLORIDA SALES: 85-8013708974C-0  
FEDERAL SALES/USE: 59-6000856

Board of County Commissions  
Seminole County, Florida

**PURCHASE ORDER**

**ORDER NUMBER:**

ORDER TYPE

ORDER DATE

REQ NUMBER

ANALYST

VENDOR NUMBER

**EXHIBIT B**

**PURCHASING AND CONTRACTS DIVISION**

130 EAST SECOND STREET  
SANFORD FLORIDA 32771  
PHONE: (407) 865-7116 / FAX: (407) 865-7956

DELIVERY

ITEM #	QUANTITY	UNIT	ITEM DESCRIPTION	UNIT PRICE	EXTENDED PRICE
					

REQUESTING DEPT/DIV

TOTAL AMOUNT

THIS ORDER IS SUBJECT TO THE TERMS & CONDITIONS ON THE REVERSE SIDE OF THIS ORDER.

**SUBMIT ALL INVOICES IN DUPLICATE TO:**

CLERK - B.C.C. FINANCE DIVISION

POST OFFICE BOX 8080

SANFORD, FL 32772-0869

Accts. Payable Inquiries - Phone (407) 865-7681

\_\_\_\_\_  
PURCHASING AND CONTRACTS DIVISION - AUTHORIZED SIGNATURE

for: SEMINOLE COUNTY BOARD OF COUNTY COMMISSIONERS



# CERTIFICATE OF LIABILITY INSURANCE

DATE (MM/DD/YYYY)  
11/21/2014

THIS CERTIFICATE IS ISSUED AS A MATTER OF INFORMATION ONLY AND CONFERS NO RIGHTS UPON THE CERTIFICATE HOLDER. THIS CERTIFICATE DOES NOT AFFIRMATIVELY OR NEGATIVELY AMEND, EXTEND OR ALTER THE COVERAGE AFFORDED BY THE POLICIES BELOW. THIS CERTIFICATE OF INSURANCE DOES NOT CONSTITUTE A CONTRACT BETWEEN THE ISSUING INSURER(S), AUTHORIZED REPRESENTATIVE OR PRODUCER, AND THE CERTIFICATE HOLDER.

IMPORTANT: If the certificate holder is an ADDITIONAL INSURED, the policy(ies) must be endorsed. If SUBROGATION IS WAIVED, subject to the terms and conditions of the policy, certain policies may require an endorsement. A statement on this certificate does not confer rights to the certificate holder in lieu of such endorsement(s).

<b>PRODUCER</b> First Niagara Risk Management, Inc 726 Exchange Street Suite 900  Buffalo NY 14210		<b>CONTACT NAME:</b> Christian Ruiz <b>PHONE (A/C No. Ext):</b> (716) 819-5500 <b>FAX (A/C No.):</b> (716) 819-5140 <b>E-MAIL ADDRESS:</b> christian.ruiz@fnrm.com	
		<b>INSURER(S) AFFORDING COVERAGE</b>	<b>NAIC #</b>
		<b>INSURER A:</b> Nat'l Union Fire Ins Co of Pitt	19445
		<b>INSURER B:</b> New Hampshire Ins Co	23841
		<b>INSURER C:</b>	
		<b>INSURER D:</b>	
		<b>INSURER E:</b>	
		<b>INSURER F:</b>	

**COVERAGES**                      **CERTIFICATE NUMBER:** 14-15                      **REVISION NUMBER:**

THIS IS TO CERTIFY THAT THE POLICIES OF INSURANCE LISTED BELOW HAVE BEEN ISSUED TO THE INSURED NAMED ABOVE FOR THE POLICY PERIOD INDICATED. NOTWITHSTANDING ANY REQUIREMENT, TERM OR CONDITION OF ANY CONTRACT OR OTHER DOCUMENT WITH RESPECT TO WHICH THIS CERTIFICATE MAY BE ISSUED OR MAY PERTAIN, THE INSURANCE AFFORDED BY THE POLICIES DESCRIBED HEREIN IS SUBJECT TO ALL THE TERMS, EXCLUSIONS AND CONDITIONS OF SUCH POLICIES. LIMITS SHOWN MAY HAVE BEEN REDUCED BY PAID CLAIMS.

INSR LTR	TYPE OF INSURANCE	ADDL SUBR INSR	WVD	POLICY NUMBER	POLICY EFF (MM/DD/YYYY)	POLICY EXP (MM/DD/YYYY)	LIMITS
A	GENERAL LIABILITY						EACH OCCURRENCE \$ 3,000,000
	<input checked="" type="checkbox"/> COMMERCIAL GENERAL LIABILITY						DAMAGE TO RENTED PREMISES (Ea occurrence) \$ 500,000
	<input type="checkbox"/> CLAIMS-MADE <input checked="" type="checkbox"/> OCCUR	X	X	7267135	7/1/2014	7/1/2015	MED EXP (Any one person) \$ 10,000
	<input checked="" type="checkbox"/> XCU Included						PERSONAL & ADV INJURY \$ 1,000,000
	<input checked="" type="checkbox"/> Contractual Liability						GENERAL AGGREGATE \$ 6,000,000
	GEN'L AGGREGATE LIMIT APPLIES PER:						PRODUCTS - COMP/OP AGG \$ 6,000,000
	<input type="checkbox"/> POLICY <input checked="" type="checkbox"/> PROJ <input type="checkbox"/> LOC						\$
A	AUTOMOBILE LIABILITY						COMBINED SINGLE LIMIT (Ea accident) \$ 1,000,000
	<input checked="" type="checkbox"/> ANY AUTO			3500763 - MA	7/1/2014	7/1/2015	BODILY INJURY (Per person) \$
	<input type="checkbox"/> ALL OWNED AUTOS			3500764 - FL			BODILY INJURY (Per accident) \$
	<input checked="" type="checkbox"/> HIRED AUTOS						PROPERTY DAMAGE (Per accident) \$
	<input checked="" type="checkbox"/> SCHEDULED AUTOS	X	X				Physical Damage \$ ACV
	<input checked="" type="checkbox"/> NON-OWNED AUTOS						
	<input checked="" type="checkbox"/> \$250 Comp/\$250 Coll ded						
	UMBRELLA LIAB						EACH OCCURRENCE \$
	EXCESS LIAB						AGGREGATE \$
	DED						\$
	RETENTION \$						\$
B	WORKERS COMPENSATION AND EMPLOYERS' LIABILITY		X				<input checked="" type="checkbox"/> WC STATUTORY LIMITS <input type="checkbox"/> OTHER
	ANY PROPRIETOR/PARTNER/EXECUTIVE OFFICER/MEMBER EXCLUDED? (Mandatory in NH)	Y/N		018962583	7/1/2014	7/1/2015	E.L. EACH ACCIDENT \$ 1,000,000
	If yes, describe under DESCRIPTION OF OPERATIONS below	N	N/A				E.L. DISEASE - EA EMPLOYEE \$ 1,000,000
							E.L. DISEASE - POLICY LIMIT \$ 1,000,000

DESCRIPTION OF OPERATIONS / LOCATIONS / VEHICLES (Attach ACORD 101, Additional Remarks Schedule, if more space is required)  
RE: Term Contract for Pavement; Management; Program Services; IFB-602096-14/BJC; Seminole County, FL TMC Job #48300. Board of County Commissioners, Seminole County is an Additional Insured on a primary and non-contributory basis in regard to the above Liability policies when required by executed written contract. 30-Day Notice of Cancellation, except for non-payment, applies in favor of the certificate holder.

<b>CERTIFICATE HOLDER</b>  enichols@seminolecountyfl.  Board of County Commissioners Seminole County Purchasing & Contracts Division 1301 East Second Street Sanford, FL 32771	<b>CANCELLATION</b>  SHOULD ANY OF THE ABOVE DESCRIBED POLICIES BE CANCELLED BEFORE THE EXPIRATION DATE THEREOF, NOTICE WILL BE DELIVERED IN ACCORDANCE WITH THE POLICY PROVISIONS.  AUTHORIZED REPRESENTATIVE  Michael Bonetto/CRUIZ
--	---



**THIS ENDORSEMENT CHANGES THE POLICY. PLEASE READ IT CAREFULLY.**

**ADDITIONAL INSURED – OWNERS, LESSEES OR  
CONTRACTORS – COMPLETED OPERATIONS**

This endorsement modifies insurance provided under the following:

COMMERCIAL GENERAL LIABILITY COVERAGE PART

**SCHEDULE**

<b>Name Of Additional Insured Person(s) Or Organization(s):</b>	<b>Location And Description Of Completed Operations</b>
ANY ENTITY YOU ARE REQUIRED IN A WRITTEN "INSURED CONTRACT" (HEREINAFTER CALLED ADDITIONAL INSURED) TO NAME AS AN INSURED	
Information required to complete this Schedule, if not shown above, will be shown in the Declarations.	

**Section II – Who Is An Insured** is amended to include as an additional insured the person(s) or organization(s) shown in the Schedule, but only with respect to liability for "bodily injury" or "property damage" caused, in whole or in part, by "your work" at the location designated and described in the schedule of this endorsement performed for that additional insured and included in the "products-completed operations hazard".

**THIS ENDORSEMENT CHANGES THE POLICY. PLEASE READ IT CAREFULLY.**

**ADDITIONAL INSURED – OWNERS, LESSEES OR CONTRACTORS – SCHEDULED PERSON OR ORGANIZATION**

This endorsement modifies insurance provided under the following:

COMMERCIAL GENERAL LIABILITY COVERAGE PART

**SCHEDULE**

Name Of Additional Insured Person(s) Or Organization(s):	Location(s) Of Covered Operations
<p>ANY ENTITY YOU ARE REQUIRED IN A WRITTEN "INSURED CONTRACT" (HEREINAFTER CALLED ADDITIONAL INSURED) TO NAME AS AN INSURED</p>	

Information required to complete this Schedule, if not shown above, will be shown in the Declarations.

**A. Section II – Who Is An Insured** is amended to include as an additional insured the person(s) or organization(s) shown in the Schedule, but only with respect to liability for "bodily injury", "property damage" or "personal and advertising injury" caused, in whole or in part, by:

1. Your acts or omissions; or
2. The acts or omissions of those acting on your behalf;

in the performance of your ongoing operations for the additional insured(s) at the location(s) designated above.

**B.** With respect to the insurance afforded to these additional insureds, the following additional exclusions apply:

This insurance does not apply to "bodily injury" or "property damage" occurring after:

1. All work, including materials, parts or equipment furnished in connection with such work, on the project (other than service, maintenance or repairs) to be performed by or on behalf of the additional insured(s) at the location of the covered operations has been completed; or
2. That portion of "your work" out of which the injury or damage arises has been put to its intended use by any person or organization other than another contractor or subcontractor engaged in performing operations for a principal as a part of the same project.



**ENDORSEMENT**

This endorsement, effective **12:01 A.M.** 07/01/14 forms a part of Policy No. 7267135

issued to ANY ENTITY YOU ARE REQUIRED IN A WRITTEN  
"INSURED CONTRACT" (HEREINAFTER CALLED  
ADDITIONAL INSURED) TO NAME AS AN INSURED  
by National Union Fire Insurance Co.

**ADDITIONAL INSURED - PRIMARY INSURANCE**

*This endorsement modifies insurance provided under the following:*

**COMMERCIAL LIABILITY COVERAGE FORM**

**Section IV, Commercial General Liability Conditions, paragraph 4., Other Insurance, subparagraph a. Primary Insurance,** is amended by the addition of the following:

However, coverage under this policy afforded to an additional insured will apply as primary insurance where required by contract, and any other insurance issued to such additional insured shall apply as excess and noncontributory insurance.



\_\_\_\_\_  
**Authorized Representative**

## WAIVER OF TRANSFER OF RIGHTS OF RECOVERY AGAINST OTHERS TO US

This endorsement modifies insurance provided under the following:

COMMERCIAL GENERAL LIABILITY COVERAGE PART  
PRODUCTS/COMPLETED OPERATIONS LIABILITY COVERAGE PART

### SCHEDULE

**Name Of Person Or Organization:**

PURSUANT TO APPLICABLE WRITTEN CONTRACT OR AGREEMENT YOU ENTER INTO.

Information required to complete this Schedule, if not shown above, will be shown in the Declarations.

The following is added to Paragraph 8. Transfer Of Rights Of Recovery Against Others To Us of Section IV - Conditions:

We waive any right of recovery we may have against the person or organization shown in the Schedule above because of payments we make for injury or damage arising out of your ongoing operations or "your work" done under a contract with that person or organization and included in the "products-completed operations hazard". This waiver applies only to the person or organization shown in the Schedule above.

**ENDORSEMENT**

This endorsement, effective 12:01 A.M. 7/01/2014 forms a part of

policy No. 3500763 - MA / 3500764 - FL issued to THE MIDDLESEX CORPORATION

by National Union Fire Ins Co, of Pittsburgh, PA

**THIS ENDORSEMENT CHANGES THE POLICY. PLEASE READ IT CAREFULLY.**

**WAIVER OF TRANSFER OF RIGHTS OF RECOVERY AGAINST OTHERS TO US**

*This endorsement modifies insurance provided under the following:*

**BUSINESS AUTO COVERAGE FORM**

**Section IV - Business Auto Conditions, A. - Loss Conditions, 5. - Transfer of Rights of Recovery Against Others to Us**, is amended to add:

However, we will waive any right of recover we have against any person or organization with whom you have entered into a contract or agreement because of payments we make under this Coverage Form arising out of an "accident" or "loss" if:

- (1) The "accident" or "loss" is due to operations undertaken in accordance with the contract existing between you and such person or organization; and
- (2) The contract or agreement was entered into prior to any "accident" or "loss".

No waiver of the right of recovery will directly or indirectly apply to your employees or employees of the person or organization, and we reserve our rights or lien to be reimbursed from any recovery funds obtained by any injured employee.

  
\_\_\_\_\_  
AUTHORIZED REPRESENTATIVE

**ENDORSEMENT**

This endorsement, effective 12:01 A.M. 7/01/2014 forms a part of

policy No. 3500763 - MA / 3500764 - FL issued to THE MIDDLESEX CORPORATION

by National Union Fire Ins Co, of Pittsburgh, PA

**THIS ENDORSEMENT CHANGES THE POLICY. PLEASE READ IT CAREFULLY.**

**ADDITIONAL INSURED - WHERE REQUIRED UNDER CONTRACT OR AGREEMENT**

*This endorsement modifies insurance provided under the following:*

**BUSINESS AUTO COVERAGE FORM**

**SCHEDULE**

**ADDITIONAL INSURED:**

ANY PERSON OR ORGANIZATION FOR WHOM YOU ARE CONTRACTUALLY BOUND TO PROVIDE ADDITIONAL INSURED STATUS BUT ONLY TO THE EXTENT OF SUCH PERSON OR ORGANIZATIONS LIABILITY ARISING OUT OF THE USE OF A COVERED "AUTO".

**I. SECTION II - LIABILITY COVERAGE, A. Coverage, 1. - Who is Insured, is amended to add:**

d. Any person or organization, shown in the schedule above, to whom you become obligated to include as an additional insured under this policy, as a result of any contract or agreement you enter into which requires you to furnish insurance to that person or organization of the type provided by this policy, but only with respect to liability arising out of use of a covered "auto". However, the insurance provided will not exceed the lesser of:

- (1) The coverage and/or limits of this policy, or
- (2) The coverage and/or limits required by said contract or agreement.

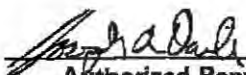
  
Authorized Representative or  
Countersignature (in States Where  
Applicable)

**WAIVER OF OUR RIGHT TO RECOVER FROM OTHERS ENDORSEMENT**

This endorsement changes the policy to which it is attached effective on inception date of the policy unless a different date is indicated below.

(The following "attaching clause" need be completed only when this endorsement is issued subsequent to preparation of the policy).

This endorsement, effective 12:01 AM 7/01/2014 forms a part of Policy No. WC 018962583

Issued to The Middlesex Corporation

By NEW HAMPSHIRE INSURANCE COMPANY

Premium INCLUDED

We have the right to recover our payments from anyone liable for an injury covered by this policy. We will not enforce our right against the person or organization named in the Schedule. This agreement applies only to the extent that you perform work under a written contract that requires you to obtain this agreement from us.

This agreement shall not operate directly or indirectly to benefit any one not named in the Schedule.

**Schedule**

Orange County Board of County Commissioners  
Purchasing & Contracts Division  
400 E. South Street  
Orlando, FL 32801

This form is not applicable in California, Kentucky, New Hampshire, New Jersey, North Dakota, Ohio, Tennessee, Texas, Utah, or Washington.

WC 00 03 13  
(Ed. 04/84)

Countersigned by \_\_\_\_\_



Authorized Representative



IFB-602096-14/BJC - Pavement Management Program

Group VII: Earthwork

Pay Item No.	Description	0-1499 SY	1500 SY and Over			Sum of Extended Cost	
160-4	Type B Stabilization -12" LBR 40	Estimated 1000 SY: \$ 25.00 /SY Total: \$ 25,000.00	Estimated 3000 SY: \$ 18.50 /SY Total: \$ 55,500.00			\$ 80,500.00	
285-701	Base Group 01 (Limerock LBR 100)	Estimated 1000 SY: \$ 25.50 /SY Total: \$ 25,500.00	Estimated 1500 SY: \$ 18.00 /SY Total: \$ 27,000.00			\$ 52,500.00	
285-706	Base Group 06 (Limerock LBR 100)	Estimated 1000 SY: \$ 30.00 /SY Total: \$ 30,000.00	Estimated 1500 SY: \$ 22.00 /SY Total: \$ 33,000.00			\$ 63,000.00	
285-709-A	Base Group 09 (Limerock LBR 100)	Estimated 1000 SY: \$ 32.00 /SY Total: \$ 32,000.00	Estimated 3000 SY: \$ 26.00 /SY Total: \$ 78,000.00			\$ 110,000.00	
285-709-B	Base Group 09 (8" Type B-12.5)	Estimated 1000 SY: \$ 65.00 /SY Total: \$ 65,000.00	Estimated 4000 SY: \$ 39.00 /SY Total: \$ 156,000.00			\$ 221,000.00	
577-70	Shoulder Rework	Estimated 1000 SY: \$ 20.00 /SY Total: \$ 20,000.00	Estimated 3000 SY: \$ 12.50 /SY Total: \$ 37,500.00			\$ 57,500.00	
Pay Item No.	Description	0-1000 CY	1001 CY and Over			Sum of Extended Cost	
120-1	Regular Excavation	Estimated 1000 CY: \$ 35.00 /CY Total: \$ 35,000.00	Estimated 2500 CY: \$ 25.00 /CY Total: \$ 62,500.00			\$ 97,500.00	
120-6	Embankment	Estimated 1000 CY: \$ 55.00 /CY Total: \$ 55,000.00	Estimated 2500 CY: \$ 38.00 /CY Total: \$ 95,000.00			\$ 150,000.00	
Company Name: <u>The Middlesex Corporation</u>						<b>TOTAL FOR GROUP VII</b>	<b>\$ 832,000.00</b>



PURCHASING AND CONTRACTS DIVISION



October 10, 2018

The Middlesex Corporation  
One Spectacle Pond Road  
Littleton, Massachusetts 01460

**Re: Renewal #2 (FINAL): IFB-602096-14/BJC (Pavement Management Program for Seminole County)**

To Whom It May Concern:

In accordance with the terms and conditions of subject Agreement, the Agreement is extended for an additional one (1) year period.

The County has evaluated your performance during the past year and determined to extend the agreement for an additional year effective: **December 2, 2018 through December 1, 2019.**

Authorization for performance of services by the Contractor under this agreement shall be in the form of written Release Orders issued and executed by the County on an as-needed basis based on the terms and conditions of the agreement.

Appropriate County Departments and Divisions will be notified of this renewal.

If you have any questions or need further assistance, please contact our office.

Sincerely,

Michael Guild  
Procurement Technician

cc: Calvin Landers, Public Works  
County Comptroller's Office  
County Attorney's Office  
File

## **Guild, Michael**

---

**From:** Landers, Calvin  
**Sent:** Tuesday, September 25, 2018 3:42 PM  
**To:** Guild, Michael  
**Subject:** RE: Renewal #2 (FINAL) - IFB-602096-14/BJC - Department Approval Needed (3 of 4)

**Follow Up Flag:** Follow up  
**Flag Status:** Flagged

Michael,

Please renew.

Calvin,

Calvin Landers, P.E.  
Assistant County Engineer  
Seminole County Department of Public Works  
Engineering Division - Construction Management  
100 E 1<sup>st</sup> Street  
Sanford, FL 32771  
Office 407-665-2332  
[clanders02@seminolecountyfl.gov](mailto:clanders02@seminolecountyfl.gov)

**From:** Guild, Michael  
**Sent:** Tuesday, September 25, 2018 1:48 PM  
**To:** Landers, Calvin <[clanders02@seminolecountyfl.gov](mailto:clanders02@seminolecountyfl.gov)>  
**Subject:** Renewal #2 (FINAL) - IFB-602096-14/BJC - Department Approval Needed (3 of 4)

Good Afternoon,

- Contract Number: **IFB-602096-14/BJC**
- Contract Title: **Term Contract for Pavement Management Program Services**
- Vendor/Business: **The Middlesex Corporation**

The current contract will expire by its own terms on **December 1, 2018**. It may be extended for one (1) additional year. **If you are in agreement with renewing this contract, please respond to this e-mail and we will complete the renewal process.**

Please let me know if you need any further information.

V/R,

Michael Guild

Michael Guild, Procurement Technician  
Resource Management, Purchasing and Contracts Division  
1301 E. Second St, Sanford, FL 32771  
PH: 407-665-7116 FX: 407-665-7956

## Guild, Michael

---

**From:** Evelyn Sergeant <esergeant@middlesexco.com>  
**Sent:** Tuesday, September 04, 2018 1:57 PM  
**To:** PCDAdmin  
**Cc:** Joe Meier; Kirk Pettengill  
**Subject:** RE: Contract Renewal Option - 2nd Notification  
**Attachments:** Board-of-County-Com\_The-Middlesex-C\_1-GL-AL-WC-18-1\_6-25-2018\_13946783\_1.pdf

**Follow Up Flag:** Follow up  
**Flag Status:** Flagged

The agreement may be renewed with the same pricing structure, specifications, term and conditions as the current order. Please see response below, current Certificate of Insurance is attached.

Thank you.

-----Original Message-----

From: purch@seminolecountyfl.gov <purch@seminolecountyfl.gov>  
Sent: Saturday, September 01, 2018 8:02 AM  
To: Evelyn Sergeant <esergeant@middlesexco.com>  
Subject: Contract Renewal Option - 2nd Notification

The current contract IFB-602096-14/BJC Pavement Management Program for Seminole County between your firm, The Middlesex Corporation, and Seminole County is about to expire ON 12/1/2018. The contract may be extended for additional annual terms. The County appreciates your business and at this time, we would like to determine whether your firm is interested in renewing the agreement.

Therefore, in order to evaluate your contract for renewal, please complete the information below and indicate any changes, including price reductions, new or additional discounts, etc., you would like to propose.

The agreement can be renewed with the same pricing structure, specifications, terms and conditions as the current order.

Modifications or changes that you would like the County to renew (please provide backup information for these proposed changes).

I do not wish to renew the agreement.

If you are in agreement with renewing the current contract, please respond to pcdadmin@seminolecountyfl.gov. Telephone Number 407-665-7116. Please send the Certificate of Insurance in accordance with the Agreement for the renewal term.

This is the first step of the renewal process. Once the renewal process has been approved and completed, you will receive the renewal letter in a separate email; this e-mail renewal notification will be confirmation that the County has officially renewed the Agreement.

Evelyn Sergeant  
The Middlesex Corporation  
Estimating Coordinator  
10801 Cosmonaut Blvd.  
Orlando, FL 32824  
O: 407-515-3566  
M:

[[http://i1140.photobucket.com/albums/n563/Middlesexco/Middlesexcorpreflex-2\\_zpsf05f9d15.png](http://i1140.photobucket.com/albums/n563/Middlesexco/Middlesexcorpreflex-2_zpsf05f9d15.png)]<http://www.middlesexco.com/>>

[www.middlesexco.com](http://www.middlesexco.com) <<http://www.middlesexco.com/>> This e-mail and any attachments are confidential and may be protected by legal, professional or other privilege.

If you are not the intended recipient you should not store it, copy it, or disclose its contents, but should return it to the sender and delete your copy from your system.

The views expressed are those of the sender and not those of The Middlesex Corporation.



# CERTIFICATE OF LIABILITY INSURANCE

DATE (MM/DD/YYYY)
6/25/2018

**THIS CERTIFICATE IS ISSUED AS A MATTER OF INFORMATION ONLY AND CONFERS NO RIGHTS UPON THE CERTIFICATE HOLDER. THIS CERTIFICATE DOES NOT AFFIRMATIVELY OR NEGATIVELY AMEND, EXTEND OR ALTER THE COVERAGE AFFORDED BY THE POLICIES BELOW. THIS CERTIFICATE OF INSURANCE DOES NOT CONSTITUTE A CONTRACT BETWEEN THE ISSUING INSURER(S), AUTHORIZED REPRESENTATIVE OR PRODUCER, AND THE CERTIFICATE HOLDER.**

**IMPORTANT: If the certificate holder is an ADDITIONAL INSURED, the policy(ies) must have ADDITIONAL INSURED provisions or be endorsed. If SUBROGATION IS WAIVED, subject to the terms and conditions of the policy, certain policies may require an endorsement. A statement on this certificate does not confer rights to the certificate holder in lieu of such endorsement(s).**

<b>PRODUCER</b> Alliant Insurance Services, Inc. 200 S. Wacker Drive, Suite 3030 Chicago IL 60606	<b>CONTACT NAME:</b>		<b>PHONE (A/C, No, Ext):</b> 312-546-5624		<b>FAX (A/C, No):</b>
	<b>E-MAIL ADDRESS:</b> TMCerts@alliant.com				
<b>INSURER(S) AFFORDING COVERAGE</b>					<b>NAIC #</b>
<b>INSURER A:</b> Zurich American Insurance Company					16535
<b>INSURER B:</b> American Zurich Insurance Company					40142
<b>INSURER C:</b>					
<b>INSURER D:</b>					
<b>INSURER E:</b>					
<b>INSURER F:</b>					

<b>INSURED</b> The Middlesex Corporation One Spectacle Pond Road Littleton, MA 01460	MIDSEXC-01
---	------------

**COVERAGES CERTIFICATE NUMBER: 13946783 REVISION NUMBER:**

**THIS IS TO CERTIFY THAT THE POLICIES OF INSURANCE LISTED BELOW HAVE BEEN ISSUED TO THE INSURED NAMED ABOVE FOR THE POLICY PERIOD INDICATED. NOTWITHSTANDING ANY REQUIREMENT, TERM OR CONDITION OF ANY CONTRACT OR OTHER DOCUMENT WITH RESPECT TO WHICH THIS CERTIFICATE MAY BE ISSUED OR MAY PERTAIN, THE INSURANCE AFFORDED BY THE POLICIES DESCRIBED HEREIN IS SUBJECT TO ALL THE TERMS, EXCLUSIONS AND CONDITIONS OF SUCH POLICIES. LIMITS SHOWN MAY HAVE BEEN REDUCED BY PAID CLAIMS.**

INSR LTR	TYPE OF INSURANCE	ADDL INSD	SUBR WVD	POLICY NUMBER	POLICY EFF (MM/DD/YYYY)	POLICY EXP (MM/DD/YYYY)	LIMITS
A	<input checked="" type="checkbox"/> <b>COMMERCIAL GENERAL LIABILITY</b> <input type="checkbox"/> CLAIMS-MADE <input checked="" type="checkbox"/> OCCUR <input checked="" type="checkbox"/> Contractual Liab <input checked="" type="checkbox"/> XCU Included GEN'L AGGREGATE LIMIT APPLIES PER: <input type="checkbox"/> POLICY <input checked="" type="checkbox"/> PRO-JECT <input checked="" type="checkbox"/> LOC OTHER:	Y	Y	GLO0381369-03	7/1/2018	7/1/2019	EACH OCCURRENCE \$ 2,000,000 DAMAGE TO RENTED PREMISES (Ea occurrence) \$ 2,000,000 MED EXP (Any one person) \$ 10,000 PERSONAL & ADV INJURY \$ 2,000,000 GENERAL AGGREGATE \$ 4,000,000 PRODUCTS - COMP/OP AGG \$ 4,000,000 \$
A	<input checked="" type="checkbox"/> <b>AUTOMOBILE LIABILITY</b> <input checked="" type="checkbox"/> ANY AUTO OWNED AUTOS ONLY <input checked="" type="checkbox"/> HIRED AUTOS ONLY <input type="checkbox"/> SCHEDULED AUTOS NON-OWNED AUTOS ONLY	Y	Y	BAP0381370-03	7/1/2018	7/1/2019	COMBINED SINGLE LIMIT (Ea accident) \$ 1,000,000 BODILY INJURY (Per person) \$ BODILY INJURY (Per accident) \$ PROPERTY DAMAGE (Per accident) \$ \$
	<input type="checkbox"/> <b>UMBRELLA LIAB</b> OCCUR <input type="checkbox"/> <b>EXCESS LIAB</b> CLAIMS-MADE DED RETENTION \$						EACH OCCURRENCE \$ AGGREGATE \$ \$
B	<input checked="" type="checkbox"/> <b>WORKERS COMPENSATION AND EMPLOYERS' LIABILITY</b> ANY PROPRIETOR/PARTNER/EXECUTIVE OFFICER/MEMBER EXCLUDED? (Mandatory in NH) If yes, describe under DESCRIPTION OF OPERATIONS below	Y	N/A	WC0381368-03	7/1/2018	7/1/2019	<input checked="" type="checkbox"/> PER STATUTE <input type="checkbox"/> OTH-ER E.L. EACH ACCIDENT \$ 1,000,000 E.L. DISEASE - EA EMPLOYEE \$ 1,000,000 E.L. DISEASE - POLICY LIMIT \$ 1,000,000

**DESCRIPTION OF OPERATIONS / LOCATIONS / VEHICLES (ACORD 101, Additional Remarks Schedule, may be attached if more space is required)**  
 RE: TMC Job #48300. Term Contract for Pavement Management Program Services; IFB-602096-14/BJC, Seminole County, FL.

Board of County Commissioners, Seminole County is included as Additional Insured on a Primary/Non-Contributory basis with respect to the above General Liability, Automobile Liability and Excess Liability Policies as required by a written contract. A Waiver of Subrogation is provided in favor of the Additional Insureds, but only to the extent permitted by law as required by a written contract. No policy will permit cancellation or modification without thirty (30) days prior written notice.

<b>CERTIFICATE HOLDER</b>  Board of County Commissioners, Seminole County Purchasing & Contracts Division 1301 East Second Street Sanford FL 32771	<b>CANCELLATION</b>  SHOULD ANY OF THE ABOVE DESCRIBED POLICIES BE CANCELLED BEFORE THE EXPIRATION DATE THEREOF, NOTICE WILL BE DELIVERED IN ACCORDANCE WITH THE POLICY PROVISIONS.  AUTHORIZED REPRESENTATIVE 
--	--

**ASPHALT RESURFACING OF VARIOUS CITY STREETS  
PRICING FORM**

ITEM NUMBER	DESCRIPTION	UNIT	QUANTITY	UNIT PRICE	TOTAL
1	MOBILIZATION	LS	1	\$ 40,000.00	\$ 40,000.00
2	MAINTENANCE OF TRAFFIC	LS	1	\$ 39,000.00	\$ 39,000.00
3	EROSION PROTECTION	LS	1	\$ 1,000.00	\$ 1,000.00
4	MILLING OF EXISTING ASPHALT (1.75" AVG DEPTH)	SY	51,783	\$ 1.80	\$ 93,209.40
5	SUPERPAVE ASPHALTIC CONCRETE SP-12.5 (TRAFFIC C)	TN	4,279	\$ 82.00	\$ 350,878.00
6	<del>MOSS</del> <sup>Torcaso</sup> PARK PARKING LOT	LS	1	\$ 42,000.00	\$ 42,000.00
<b>TOTAL PRICE (SUM OF ITEMS #1 THROUGH #6):</b>					<b>\$ 566,087.40</b>
<b>PAY ITEM NOTES:</b>					
2	Includes the cost of all items needed for traffic control, (barricades, flagmen, temporary variable message signs, etc.) in accordance with FDOT standards				
4	The milling depth is an average of 1.75". Some streets will require a milling depth greater than 1.75" in order to maintain a finished asphalt edge from 0" to a maximum of 1/4" above gutters and driveways. The thickness of new asphalt is 1.5" unless noted otherwise.				
5	Quantity based on 110 lbs per square yard per 1-inch lift				
5	Unit price includes all equipment, labor, and materials including bituminous material (plant mixes, prime coats, and tack coats) and all other incidental costs to complete the work. <sup>Torcaso</sup>				
6	The lump sum item for the <del>Moss</del> <sup>Torcaso</sup> Park Parking Lot includes all preparation costs. The estimated square yardage for the mill and resurface area is 1300 SY. This is to meet the tolerances listed in Item 4. Approximately 250 SY will be asphalt over rolled millings. The lump sum item includes mobilization, maintenance of traffic, re-grading, compaction, rolling of asphalt millings and asphalt. Any miscellaneous work required to complete this line item, including but not limited to installation, restoration, and cleanup, should be included within the lump sum price. The asphalt and milling quantity of this lump sum item is to be included within Bid Item #6.				



PROJECT		PROJECT TYPE	TOTAL YARDS	STRUCTURAL COURSE TONS (110 LB/SY/IN)
<b>FY 2018-2019</b>				
1	Winter Springs Boulevard [Tuskawilla to Benchwood]	RESURFACE	3212	265
2	Trotwood Boulevard [Tuskawilla to Endeavor]	RESURFACE	990	82
3	Bennet Street	RESURFACE	2444.2	202
4	Partridge Circle	RESURFACE	5387.8	445
5	Tarpon Circle	RESURFACE	4665.1	385
6	Shadowbrook Trail	RESURFACE	4694.8	388
7	Papaya Lane and Cottontail Court	RESURFACE	8952.9	739
8	Night Owl Lane and Night Owl Court	RESURFACE	4803.7	397
9	S. Cortez Avenue [Lombardy to Alderwood]	RESURFACE	1967.9	163
10	Evergreen Avenue and Gumtree Court	RESURFACE	4182.2	346
11	N. 2nd Street	RESURFACE	1716	142
12	Charles Street	RESURFACE	2114.2	175
13	Sleeping Rock Court	RESURFACE	2128.5	176
14	White Dove Drive	RESURFACE	4523.2	374
TOTAL			51783	4279



# CONSENT AGENDA ITEM 304

CITY COMMISSION REVISED AGENDA  
AUGUST 12, 2019 | REGULAR MEETING

## TITLE

NRCS Sediment Removal Project Additional Funding Request

## SUMMARY

At the July 09, 2018 City Commission meeting, the City Commission authorized the City of Winter Springs to enter into a Project Agreement (Exhibit A) with the Natural Resources Conservation Service (NRCS) for federal and local match funding of Emergency Watershed Protection projects as a result of damages from Hurricane Irma. Some of the projects included the removal of sediment and debris at various locations of the City. The locations of the sediment removal portion of these projects are Winter Springs Blvd at Bear Creek, S. Edgemon Ave at Gee Creek, and Moss Road at Gee Creek. The initial cost estimate for the sediment and debris removal was \$157,710 with a City share of \$39,427.50. The initial sediment removal portion was estimated at \$77,010, with a City share of \$19,252.50.

Due to unforeseen price increases in this area of construction, the City is requesting an additional \$206,000 to make up for the funding gaps in the initial estimates and the project bids. The additional funds would allow the City to complete this project at all three locations to improve water flow through the creeks.

## RECOMMENDATION

Staff recommends the City Commission approve a supplemental appropriation up to \$206,000 from the Solid Waste Storm Reserve assigned fund balance for a transfer to the Stormwater fund to be utilized for sediment removal in City creeks. Additionally, approval is needed in the Stormwater fund for a revenue-neutral budget adjustment reflecting the 'transfer in' and equivalent expenditure.



U.S. Department of Agriculture  
Natural Resources Conservation Service

Exhibit A

**NOTICE OF GRANT AND AGREEMENT AWARD**

1. Award Identifying Number  NR184209XXXXC034	2. Amendment Number	3. Award /Project Period  07/12/2018 - 02/17/2019	4. Type of award instrument:  Cooperative Agreement
5. Agency (Name and Address)  Natural Resources Conservation Service P. O. Box 141510 Gainesville, FL 32614-1510		6. Recipient Organization (Name and Address)  WINTER SPRINGS CITY OF 1126 EAST STATE ROAD 434 WINTER SPRINGS FL 32708-2715  DUNS: 025212655      EIN:	
7. NRCS Program Contact  Name: Jason Strenth Phone: (352) 338-9559 Email: jason.strenth@fl.usda.gov	8. NRCS Administrative Contact  Name: MOIRA SANFORD Phone: (614) 255-2495 Email: MOIRA.SANFORD@OH.USDA.GOV	9. Recipient Program Contact  Name: Bryant Smith Phone: 407-327-8979 Email: bsmith@winterspringsfl.org	10. Recipient Administrative Contact  Name: Kelly Balagia Phone: 407-327-7590 Email: kbalagia@winterspringsfl.org
11. CFDA  10.923	12. Authority  33 U.S.C. 701b-1	13. Type of Action  New Agreement	14. Program Director  Name: Bryant Smith Phone: 407-327-1800 Email: bsmith@winterspringsfl.org
15. Project Title/ Description: City of Winter Springs Hurricane Irma EWP - Debris Removal and Bank Stabilization  6000004098			
16. Entity Type: 02 = City or Township government			
17. Select Funding Type			
Select funding type:	<input checked="" type="checkbox"/> Federal	<input checked="" type="checkbox"/> Non-Federal	
Original funds total	\$1,516,044.92	\$448,534.00	
Additional funds total	\$0.00	\$0.00	
Grand total	\$1,516,044.92	\$448,534.00	



U.S. Department of Agriculture  
Natural Resources Conservation Service



NRCS-ADS-093

**NOTICE OF GRANT AND AGREEMENT AWARD**

1. Award Identifying Number NR184209XXXXC034	2. Amendment Number	3. Award /Project Period 220 Calendar Days from NRCS Signature	4. Type of award instrument: Cooperative Agreement
5. Agency (Name and Address)  Natural Resources Conservation Service P. O. Box 141510 Gainesville, FL 32614-1510		6. Recipient Organization (Name and Address)  WINTER SPRINGS CITY OF 1126 EAST STATE ROAD 434 WINTER SPRINGS FL 32708-2715  DUNS: 025212655      EIN:	
7. NRCS Program Contact  Name: Jason Strenth Phone: (352) 338-9559 Email: jason.strenth@fl.usda.gov	8. NRCS Administrative Contact  Name: MOIRA SANFORD Phone: (614) 255-2495 Email: MOIRA.SANFORD@OH.USDA.GOV	9. Recipient Program Contact  Name: Bryant Smith Phone: 407-327-8979 Email: bsmith@winterspringsfl.org	10. Recipient Administrative Contact  Name: Kelly Balagia Phone: 407-327-7590 Email: kbalagia@winterspringsfl.org
11. CFDA 10.923	12. Authority 33 U.S.C. 701b-1	13. Type of Action New Agreement	14. Program Director  Name: Bryant Smith Phone: 407-327-1800 Email: bsmith@winterspringsfl.org
15. Project Title/ Description: City of Winter Springs Hurricane Irma EWP - Debris Removal and Bank Stabilization  6000004098			
16. Entity Type: 02 = City or Township government			
17. Select Funding Type			
Select funding type:	<input checked="" type="checkbox"/> Federal	<input checked="" type="checkbox"/> Non-Federal	
Original funds total	\$1,516,044.92	\$448,534.00	
Additional funds total	\$0.00	\$0.00	
Grand total	\$1,516,044.92	\$448,534.00	

<b>18. Approved Budget</b>			
Personnel	\$0.00	Fringe Benefits	\$0.00
Travel	\$0.00	Equipment	\$0.00
Supplies	\$0.00	Contractual	\$0.00
Construction	\$1,345,602.00	Other	\$170,442.92
Total Direct Cost	\$1,516,044.92	Total Indirect Cost	\$0.00
		Total Non-Federal Funds	\$448,534.00
		Total Federal Funds Awarded	\$1,516,044.92
		Total Approved Budget	\$1,964,578.92

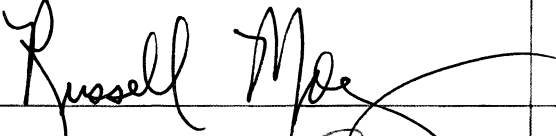
This agreement is subject to applicable USDA NRCS statutory provisions and Financial Assistance Regulations. In accepting this award or amendment and any payments made pursuant thereto, the undersigned represents that he or she is duly authorized to act on behalf of the awardee organization, agrees that the award is subject to the applicable provisions of this agreement (and all attachments), and agrees that acceptance of any payments constitutes an agreement by the payee that the amounts, if any, found by NRCS to have been overpaid, will be refunded or credited in full to NRCS.

Name and Title of Authorized Government Representative	Signature	Date
Russell Morgan State Conservationist		7-12-2018
Name and Title of Authorized Recipient Representative	Signature	Date
Kevin Smith City Manager		7/11/18

**NONDISCRIMINATION STATEMENT**

The U.S. Department of Agriculture (USDA) prohibits discrimination in all its programs and activities on the basis of race, color, national origin, age, disability, and where applicable, sex, marital status, familial status, parental status, religion, sexual orientation, genetic information, political beliefs, reprisal, or because all or a part of an individual's income is derived from any public assistance program. (Not all prohibited bases apply to all programs.) Persons with disabilities who require alternative means for communication of program information (Braille, large print, audiotape, etc.) should contact USDA's TARGET Center at (202) 720-2600 (voice and TDD). To file a complaint of discrimination write to USDA, Director, Office of Civil Rights, 1400 Independence Avenue, SW., Washington, DC 20250-9410 or call (800) 795-3272 (voice) or (202) 720-6382 (TDD). USDA is an equal opportunity provider and employer.

**PRIVACY ACT STATEMENT**

The above statements are made in accordance with the Privacy Act of 1974 (5 U.S.C. Section 522a).

## Statement of Work

### Purpose

The purpose of this agreement is for the United States Department of Agriculture, Natural Resources Conservation Service, hereinafter referred to as the "NRCS", to provide technical and financial assistance to the City of Winter Springs, hereinafter referred to as the "Sponsor", for EWP Project # 5072 (Hurricane Irma) in Winter Springs, Florida for implementation of recovery measures, that, if left undone, pose a risk to life and/or property.

### Objectives

The design and installation of EWP measures as detailed in the individual Damage Survey Report (DSR) and described here:

DSR No. IRMA-WIN-001 – Remove debris and sediment from Gee Creek = \$159,706

DSR No. IRMA-WIN-002 – Remove debris from Howell Creek = \$142,296

DSR No. IRMA-WIN-003 – Remove debris from Sheoah Creek = \$23,863

DSR No. IRMA-WIN-004 – Stabilize Gee Creek banks = \$1,368,796

DSR No. IRMA-WIN-005 – Stabilize Sheoah Creek banks = \$99,475

Total Estimated Construction Cost = \$1,794,136

### Budget Narrative

A. The estimated costs for the Project:

1. Total Estimated Project Budget: \$1,964,578.92

The budget includes:

Financial Assistance (FA) Costs:

Construction Costs (75% NRCS \$1,345,602.00 + 25% Sponsor \$448,534.00): \$1,794,136

Technical Assistance (TA) Costs:

100% NRCS (9.5% of total construction cost): \$170,442.92

2. NRCS pays up to 75 percent of eligible construction costs, and Sponsor pays 25 percent of construction costs. NRCS will contribute up to 9.5 percent of the total construction cost for design services, contract administration and construction management costs. It is possible that technical and administrative costs will exceed this amount, requiring the Sponsor to contribute resources to complete technical and administrative work.

3. NRCS funding for this project is provided to the Sponsor in two separate NRCS funding accounts, one for financial assistance (FA) and one for technical assistance (TA). FA costs are associated with construction activities; TA costs are associated with services. These expenditures shall be accounted for separately in order for expenses to be eligible for reimbursement.

4. NRCS will provide FA for actual costs as reimbursement to the Sponsor for approved on-the-ground construction costs, subject to above limits. If costs are reduced, reimbursement will be reduced accordingly. Construction costs are associated with the installation of the project measures including labor, equipment and materials.

5. NRCS will provide TA reimbursement to the Sponsor for technical and administrative costs directly charged to the project, subject to the above limits. If costs are reduced, reimbursement will be reduced accordingly. These costs include

a. engineering costs include, but not limited to, developing a project design that includes construction drawings and specifications, an operation and maintenance plan, a quality assurance/inspection plan and an engineer's estimate of the project installation costs in addition to providing necessary quality assurance during construction.

b. contract administration costs include, but not limited to, soliciting, evaluating, awarding and administering contracts for construction and engineering services, including project management, verifying invoices and record keeping.

6. The Sponsor will contribute funds toward the total construction costs in either direct cash expenditures, the value of



non-cash materials or services, or in-kind contributions. The value of any in-kind contribution shall be agreed to in writing prior to implementation.

**Responsibilities of the Parties:**

**A. Sponsor will—**

1. Accomplish construction of the EWP project measures by contracting, in-kind construction services, or a combination of both.
2. Ensure and certify by signing this agreement that its cost share obligation is from a non-Federal source.
3. Designate a project liaison to serve between the Sponsor and NRCS and identify that person's contact information with this executed agreement. Any change in the project liaison during the terms of this agreement must be immediately communicated to NRCS.
4. Appoint a contracting officer and an authorized representative who will have authority to act for the contracting officer, listing their duties, responsibilities, and authorities. Furnish such information in writing to the NRCS State Conservationist.
5. Comply with the terms and conditions of this agreement and the attached general terms and conditions except those that are not applicable to State and local governments.
6. Acquire and provide certification to NRCS that real property rights (land and water), permits and licenses in accordance with local, state, and Federal laws necessary for the installation of EWP project measures have been obtained at no cost to NRCS prior to construction. This includes any rights associated with required environmental mitigation. Sponsors shall provide such certification on Form NRCS-ADS-78, Assurances Relating to Real Property Acquisition. Sponsors shall also provide an attorney's opinion supporting this certification. Costs related to land rights and permits are the Sponsor's responsibility and ineligible for reimbursement.
7. Accept all financial and other responsibility for excess costs resulting from their failure to obtain, or their delay in obtaining, adequate land and water rights, permits and licenses needed for the Project.
8. Provide the agreed-to portion of the actual, eligible and approved construction cost. These costs may be in the form of cash, in-kind construction services, or a combination of both. Final construction items that are eligible construction costs will be agreed upon during the pre-design conference. These costs consist of costs from contracts awarded to contractors and eligible Sponsor in-kind construction costs for materials, labor, and equipment. The Sponsor shall provide NRCS documentation to support all eligible construction costs.
9. Be responsible for 100 percent of all ineligible construction costs and 100 percent of any unapproved upgrade to increase the level of protection over and above that described in the DSR.
10. Account for and report FA and TA expenditures separately in order for expenses to be eligible for reimbursement. NRCS funding for this project is provided to the Sponsor in two separate NRCS funding accounts, one for TA and one for FA, requiring this separation.
11. Contract for services and construction in accordance with the Code of Federal Regulations (CFR), 2 CFR § 200.317 through 200.326, applicable State regulations, and the Sponsor's procurement regulations, as appropriate. (See general terms and conditions attached to this agreement for a link to the CFR.) In accordance with 2 CFR § 200.326, contracts must contain the applicable provisions described in Appendix II to Part 200. Davis-Bacon Act would not apply under this Federal program legislation.
12. The contracts for design services and construction described in this Agreement shall not be awarded to the Sponsor or to any firm in which any Sponsor's official or any member of such official's immediate family has direct or indirect interest in the pecuniary profits or contracts of such firms. Reference 2 CFR § 200.318 regarding standards of conduct covering conflicts of interest and governing the performance of its employees engaged in the selection, award, and administration of contracts.
13. Any costs (construction or technical and administrative services) incurred prior to the Sponsor and NRCS signing this agreement are ineligible and will not be reimbursed.
14. For contracts, provide NRCS a copy of solicitation notice, bid abstract, and notice of contract award, or other basis of cost and accomplishment.

15. For in-kind construction services (materials, labor, and/or equipment supplied by the Sponsor), develop a Plan of Operations describing the construction services to be performed including estimated quantities and values. The Plan of Operations shall be concurred in by NRCS at the pre-design conference. In-kind construction services for equipment shall not exceed published FEMA equipment rates unless otherwise documented and concurred in advance by NRCS.

16. The following documentation is required to support the Sponsor's request for reimbursement of in-kind construction services:

- a. Invoices covering actual costs of materials used in constructing the eligible EWP project measures.
- b. Records documenting the type, quality, and quantities of materials actually used in constructing the eligible EWP project measures.
- c. Daily time records for each employee showing name, classification, wage rate, hours, and dates actually employed for constructing the eligible EWP project measures.
- d. Equipment operating records showing the type and size of equipment, hourly rate, actual hours of operation and dates used to install the eligible EWP project measures. Equipment idle time is not eligible in-kind construction services, even if on the job site, and should not be included in the equipment operating records.

17. Within thirty (30) calendar days of signing the project agreement, hold a pre-design conference with the Sponsor, Sponsor's design engineer, and NRCS. The design conference shall set forth design parameters concurred by both the Sponsor and NRCS. During the pre-design conference, NRCS will determine the eligible construction costs.

18. Within fourteen (14) calendar days of the pre-design conference submit to NRCS a schedule with time lines of major items to be completed. Milestones shall include, but not limited to, obtaining land rights, obtaining permits, completing any necessary surveys, completing draft engineering plans and specifications for NRCS review, completing final engineering plans and specifications, completing quality assurance plan, solicit bids, award contract, issue notice to proceed, and complete construction.

19. Prior to commencement of work and/or solicitation of bids, submit for NRCS review, the preliminary design, construction specifications, and engineering drawings prepared in accordance with standard engineering principles and design parameters set forth in the pre-design conference.

20. Upon receiving comments from NRCS, prepare the final design, construction specifications, and engineering drawings in accordance with standard engineering principles that comply with NRCS programmatic principles and design parameters set forth in the pre-design conference. One set of the final plans and specifications shall be submitted to NRCS for final review and concurrence prior to solicitation of bids and/or commencement of work. The final construction plans and specifications shall be signed and sealed by a licensed Professional Engineer registered in the State of Florida (Not required for debris removal only sites). A copy of the signed and seal plans and specifications shall be provided to NRCS.

21. Prior to commencement of work and/or solicitation of bids, submit for NRCS review and concurrence a Quality Assurance Plan (QAP). The QAP shall outline technical and administrative expertise required to ensure the EWP project measures are installed in accordance with the plans and specifications, identify individuals with the expertise, describe items to be inspected, list equipment required for inspection, outline the frequency and timing of inspection (continuous or periodic), outline inspection procedures, and record keeping requirements. A copy of the final QAP shall be provided to NRCS prior to commencement of construction.

22. Provide construction inspection in accordance with the QAP.

23. Prepare and submit for NRCS concurrence an Operation and Maintenance (O&M) Plan, if applicable (Not required for debris removal only sites), prior to commence of work. The O&M Plan shall describe the activities the Sponsor will do to ensure the project performs as designed. Upon completion of the project measures, the Sponsor shall assume responsibility for O&M.

24. Provide copies of site maps to appropriate Federal and State agencies for environmental review. Sponsor will notify NRCS of environmental clearance, modification of construction plans, or any unresolved concerns as well as copies of all permits, licenses, and other documents required by Federal, state, and local statutes and ordinances prior to solicitation for installation of the EWP project measures. All modifications to the plans and specifications shall be reviewed and concurred on by NRCS.

25. Ensure that any special requirements for compliance with environmental and/or cultural resource laws are incorporated into the project.

26. The Sponsor must secure at its own expense all Federal, State, and local permits and licenses necessary for completion of the work described in this agreement as well as any necessary natural resource rights and provide copies of all permits and licenses obtained to NRCS.

27. Will arrange and pay for any necessary location, removal, or relocation of utilities. EWP program regulations prohibit NRCS from reimbursing the Sponsor or otherwise paying for any such costs; nor do the costs qualify as a Sponsor cost-share contribution.

28. Ensure that technical and engineering standards and specifications of NRCS are adhered to during construction of the Project, as interpreted by NRCS Government Representative (GR). Provide NRCS Program/Technical Contact and GR progress reports every 2 weeks after execution of the agreement. Progress reports should include work accomplished for the period, technical on-site inspections, work planned, results of material tests, deficient work products and/or tests with corrective actions taken, modifications anticipated, technical problems encountered, contractual issues and other relevant information.

29. Ensure that all contractors on NRCS assisted projects are performing their work in accordance with OSHA regulations and the Contract Work Hours and Safety Standards Act (40 USC 327-330) as supplemented by Department of Labor regulations (29 CFR Part 5). The Sponsor is responsible for periodically checking the contractor's compliance with safety requirements.

30. Arrange for and conduct final inspection of completed project with NRCS to determine whether all work has been performed in accordance with contractual requirements. Provide a Professional Engineer (PE) certification that the Project was installed in accordance with approved plans and specifications. For debris removal only sites, certification does not need to be from a PE.

31. Provide PE-certified as-built drawings and quantities for the project. A copy of the as-built drawings will be submitted to the NRCS Program/Technical Contact. For debris removal only sites, as-built drawings do not need to be certified by a PE.

32. Pay the contractor(s) for work performed in accordance with the agreement and submit a SF-270, "Request for Advance or Reimbursement" to the NRCS Program/Technical Contact with all documentation to support the request. Payments can be requested as frequently as monthly. Final payment request shall be submitted within 90 calendar days of completion of the EWP project measures. Payments will be withheld until all required documentation is submitted and complete.

a. The required supporting documentation for reimbursement of construction costs include invoices and proof of payment to the contractor showing the items and quantities installed and certified by the engineer of record along with any supporting documentation such as quantity calculations, rock weight tickets, etc.

b. The required supporting documentation for reimbursement of in-kind construction expenses will include employee time sheets, employee hourly rate, equipment operating logs, equipment hourly rate, and material quantities and invoices.

c. The required documentation for reimbursement of technical and administrative services will be invoices and proof of payment to consultants and/or employee time sheets along with the employee's hourly rate, hours worked, and date work was performed.

33. Ensure that information in the System for Award Management (SAM) is current and accurate until the final financial report (SF-425) under this award or final payment is received, whichever is later.

34. Take reasonable and necessary actions to dispose of all contractual and administrative issues arising out of the contract(s) awarded under this Agreement. This includes, but is not limited to disputes, claims, protests of award, source evaluation, and litigation that may result from the Project. Such actions will be at the expense of the Sponsor, including any legal expenses. The Sponsor will advise, consult with, and obtain prior written concurrence of NRCS on any litigation matters in which NRCS could have a financial interest.

35. Sponsor must indemnify and hold NRCS harmless to the extent permitted by State law for any costs, damages, claims, liabilities, and judgments arising from past, present, and future acts or omissions of the Sponsor in connection with its acquisition and management of the Emergency Watershed Protection Program pursuant to this agreement. Further, the Sponsor agrees that NRCS will have no responsibility for acts and omissions of the Sponsor, its agents, successors, assigns, employees, contractors, or lessees in connection with the acquisition and management of the Emergency Watershed Protection Program pursuant to this agreement that result in violation of any laws and regulations that are now or that may in the future become applicable.

36. Retain all records dealing with the award and administration of the contract(s) for 3 years from the date of the Sponsor's submission of the final request for reimbursement or until final audit findings have been resolved, whichever is longer. If any litigation is started before the expiration of the 3-year period, records are to be retained until the litigation is resolved or the end of the 3-year period, whichever is longer. Make such records available to the Comptroller General of the United States or his or her duly authorized representative and accredited representatives of the Department of

Agriculture or cognizant audit agency for the purpose of making audit, examination, excerpts, and transcriptions.

37. Be liable to the NRCS for damages sustained by the NRCS as a result of the contractor failing to complete the work within the specified time. The damages will be based upon the additional costs incurred by the NRCS resulting from the contractor not completing the work within the allowable performance period. These costs include but are not limited to personnel costs, travel, etc. The NRCS will have the right to withhold such amount out of any monies that may be then due or that may become due and payable to the Sponsor. This liability is not applicable to the extent that the contract performance time is extended by court judgment unless such judgment results from actions of the Sponsor not concurred in by NRCS.

38. Take necessary legal action, including bringing suit, to collect from the contractor any monies due in connection with the contract, or upon request of NRCS, assign and transfer to NRCS any or all claims, demands, and causes of action of every kind whatsoever that the Sponsor has against the contractor or his or her sureties.

39. Submit requests for a time extension to the agreement (if necessary) in writing no less than forty-five (45) days prior to the expiration date of the agreement. Submit the written, signed request to the NRCS Program/Technical Contact.

B. NRCS will—

1. Assist Sponsor in establishing design parameters; determine eligible construction costs during the pre-design conference.

2. Designate a Government representative (GR) to serve as liaison with the Sponsor and identify that person's contact information with this executed agreement.

3. Review, comment and concur in preliminary and final plans, specifications, O&M Plan, Plan of Operations (if required) and QAP.

4. Make periodic site visits during the installation of the EWP project measures to review construction progress, document conformance to engineering plans and specifications, and provide any necessary clarification on the Sponsor's responsibilities.

5. Upon notification of the completion of the EWP project measures, NRCS shall promptly review the performance of the Sponsor to determine if the requirements of this agreement and fund expenditures as agreed have been met.

6. Make payment to the Sponsor covering NRCS' share of the cost upon receipt and approval of Form SF-270 and supporting documentation, withholding the amount of damages sustained by NRCS as provided for in this agreement. In the event there are questions regarding the SF 270 and supporting documentation, NRCS will contact the Sponsor in a timely manner to resolve concerns.

#### SPECIAL PROVISIONS

A. The furnishing of financial, administrative, and/or technical assistance above the original funding amount by NRCS is contingent on there being sufficient unobligated and uncommitted funding in the Emergency Watershed Protection Program that is available for obligation in the year in which the assistance will be provided. NRCS may not make commitments in excess of funds authorized by law or made administratively available. Congress may impose obligational limits on program funding that constrains NRCS's ability to provide such assistance.

B. In the event of default of a construction contract awarded pursuant to this agreement, any additional funds properly allocable as construction costs required to ensure completion of the job are to be provided in the same ratio as construction funds are contributed by the parties under the terms of this agreement. Any excess costs including interest resulting from a judgment collected from the defaulting contractor, or his or her surety, will be prorated between the Sponsor and NRCS in the same ratio as construction funds are contributed under the terms of the agreement.

C. Additional funds, including interest properly allocable as construction costs as determined by NRCS, required as a result of decision of the CO or a court judgment in favor of a claimant will be provided in the same ratio as construction funds are contributed under the terms of this agreement. NRCS will not be obligated to contribute funds under any agreement or commitment made by the Sponsor without prior concurrence of NRCS.

D. The State Conservationist may make adjustments in the estimated cost to NRCS set forth in this agreement for constructing the EWP measures. Such adjustments may increase or decrease the amount of estimated funds that are related to differences between such estimated cost and the amount of the awarded contract or to changes, differing site conditions, quantity variations, or other actions taken under the provisions of the contract. No adjustment will be made to change the cost sharing assistance provided by NRCS as set forth in this agreement, nor reduce funds below the amount required to carry out NRCS' share of the contract.

E. Except for item D. above, this document may be revised as mutually agreed through a written amendment duly

executed by authorized officials of all signatory parties to this agreement.

F. NRCS, at its sole discretion, may refuse to cost share should the Sponsor, in administering the contract, elect to proceed without obtaining concurrence as set out in this agreement.

G. Once the project is completed and all requests for reimbursement submitted, any excess funding remaining in the agreement will be de-obligated from the agreement.

H. If inconsistencies arise between the language in the Statement of Work (SOW) in the agreement and the general terms and conditions, the language in the SOW takes precedence.

### **Expected Accomplishments and Deliverables**

The following accomplishments and deliverable will be provided to NRCS.

1. One copy of the final engineering plans, specifications signed and sealed by a licensed professional engineer (if applicable), including engineer's cost estimate, and approved Plan of Operations (if applicable).
2. Signed NRCS-ADS-78 supported by an attorney's opinion.
3. One copy of the quality assurance plan.
4. One copy of the operation and maintenance plan (if applicable).
5. One copy of the notice of solicitation, bid abstract, and notice of award.
6. Certification that the project was installed in accordance with the plans and specifications.
7. As-built drawings of final construction signed by a licensed professional engineer within 30 days of completion of construction.
8. Quantities of the units of work applied for each site within 45 days of completion of construction.

### **Resources Required**

No resources other than funding.

### **Milestones**

Milestones shall include, but not limited to, the following items:

1. Pre-design conference within 30 days of signing agreement.
2. Submit to NRCS a schedule with time lines of major items to be completed within 14 days of the pre-design conference.
3. Acquire needed real property rights and permits (signed NRCS-ADS-78 supported by an attorney's opinion) prior to start of construction.
4. Obtain permits.
5. Complete any necessary surveys.
6. Complete draft engineering plans and specifications for NRCS review.
7. Complete final engineering plans and specifications.
8. Complete quality assurance plan and operation and maintenance plan (if applicable).
9. Solicit bids.
10. Award contract.
11. Manage construction contract and provide quality assurance as described in the QAP.
12. Provide final inspection.
13. Complete as-built drawings.
14. Submit final payment.

## GENERAL TERMS AND CONDITIONS

Please reference the below link(s) for the General Terms and Conditions pertaining to this award:

NATURAL RESOURCES CONSERVATION SERVICE U.S. DEPARTMENT OF AGRICULTURE

GENERAL TERMS AND CONDITIONS GRANTS AND COOPERATIVE AGREEMENTS

### I. APPLICABLE REGULATIONS

a. The recipient, and recipients of any subawards under this award, agree to comply with the following regulations, as applicable. The full text of Code of Federal Regulations references may be found at <https://www.gpo.gov/fdsys/browse/collectionCfr.action?collectionCode=CFR> and <http://www.ecfr.gov/>.

(1) 2 CFR Part 25, "Universal Identifier and System of Award Management" (2) 2 CFR Part 170, "Reporting Subaward and Executive Compensation Information" (3) 2 CFR Part 180, "OMB Guidelines To Agencies On Governmentwide Debarment And Suspension (Nonprocurement)" (4) 2 CFR Part 182, "Governmentwide Requirements for Drug-Free Workplace (Financial Assistance)" (5) 2 CFR Part 200, "Uniform Administrative Requirements, Cost Principles, And Audit Requirements for Federal Awards"

b. The recipient, and recipients of any subawards under this award, assure and certify that they have and/or will comply with the following regulations, as applicable. The full text of Code of Federal Regulations references may be found at <https://www.gpo.gov/fdsys/browse/collectionCfr.action?collectionCode=CFR> and <http://www.ecfr.gov/>.

(1) 2 CFR Part 175, "Award Term for Trafficking in Persons" (2) 2 CFR Part 417, "Nonprocurement Debarment and Suspension" (3) 2 CFR Part 418, "New Restrictions on Lobbying" (4) 2 CFR Part 421, "Requirements for Drug-Free Workplace (Financial Assistance)"

c. Allowable project costs will be determined in accordance with the authorizing statute, the purpose of the award, and to the extent applicable to the type of organizations receiving the award, regardless of tier. The following portions of the Code of Federal Regulations are hereby incorporated by reference. The full text of Code of Federal Regulations references may be found at <https://www.gpo.gov/fdsys/browse/collectionCfr.action?collectionCode=CFR> and <http://www.ecfr.gov/>.

(1) 2 CFR Part 200, "Uniform Administrative Requirements, Cost Principles And Audit Requirements For Federal Awards" (2) 48 CFR Part 31, "Contract Cost Principles and Procedures"

### II. UNALLOWABLE COSTS

The following costs are not allowed:

a. Costs above the amount authorized for the project b. Costs incurred after the expiration of the award including any no-cost extensions of time c. Costs that lie outside the scope of the approved project and any amendments thereto d. Compensation for injuries to persons or damage to property arising from project activities

This list is not exhaustive. For general information about the allowability of particular items of costs, please see 2 CFR Part 200, "Subpart E – Cost Principles", or direct specific inquiries to the NRCS administrative contact identified in the award.

### III. CONFIDENTIALITY

a. Activities performed under this award may involve access to confidential and potentially sensitive information about governmental and landowner issues. The term "confidential information" means proprietary information or data of a personal nature about an individual, or information or data submitted by or pertaining to an organization. This information must not be disclosed without the prior written consent of NRCS.

b. The recipient's personnel will follow the rules and procedures of disclosure set forth in the Privacy Act of 1974, 5 U.S.C. Section 552a, and implementing regulations and policies with respect to systems of records determined to be subject to the Privacy Act. The recipient's personnel must also comply with privacy of personal information relating to natural resources conservation programs in accordance with section 1244 of Title II of the Farm Security and Rural Investment Act of 2002 (Public Law 107-171).



c. The recipient agrees to comply with NRCS guidelines and requirements regarding the disclosure of information protected under Section 1619 of the Food, Conservation, and Energy Act of 2008 (PL 110-246), U.S.C. 8791.

d. The recipient agrees to comply with the "Prohibition Against Certain Internal Confidentiality Agreements:"

1. You may not require your employees, contractors, or subrecipients seeking to report fraud, waste, or abuse to sign or comply with internal confidentiality agreements or statements prohibiting or otherwise restricting them from lawfully reporting that waste, fraud, or abuse to a designated investigative or law enforcement representative of a Federal department or agency authorized to receive such information. 2. You must notify your employees, contractors, or subrecipients that the prohibitions and restrictions of any internal confidentiality agreements inconsistent with paragraph (1) of this award provision are no longer in effect. 3. The prohibition in paragraph (1) of this award provision does not contravene requirements applicable to any other form issued by a Federal department or agency governing the nondisclosure of classified information. 4. If NRCS determines that you are not in compliance with this award provision, NRCS: a. Will prohibit your use of funds under this award, in accordance with sections 743 and 744 of Division E of the Consolidated Appropriations Act, 2016, (Pub. L. 114-113) or any successor provision of law; b. May pursue other remedies available for your material failure to comply with award terms and conditions.

#### IV. PRIOR APPROVAL REQUIREMENTS

The following are the most common situations requiring prior approval. However, the recipient is also bound by any other prior approval requirements of the applicable administrative provisions and Federal cost principles.

a. Purpose or Deliverables.—When it is necessary for the recipient to modify the purpose or deliverables, the recipient must submit a written request and justification for the change along with the revised purpose or deliverables of the award to the NRCS administrative contact. The request should contain the following: 1. Grant or agreement number 2. Narrative explaining the requested modification to the project purpose or deliverables 3. A description of the revised purpose or deliverables 4. Signatures of the authorized representative, project director, or both

b. Subaward/contractual Arrangement.—The recipient must submit a justification for the proposed subaward/contractual arrangements, a statement of work to be performed, and a detailed budget for the subaward/contract to the NRCS administrative contact. Subaward/contractual arrangements disclosed in the application do not require additional postaward approval.

c. Absence or Change in Project Leadership.—When a project director or the person responsible for the direction or management of the project—

1. Relinquishes active direction of the project for more than 3 consecutive months or has a 25 percent or more reduction in time devoted to the project, the grantee must notify the NRCS administrative contact in writing, identifying who will be in charge during the project director's absence. The notification must include the qualifications and the signature of the replacement, signifying his or her willingness to serve on the project.

2. Severs his or her affiliation with the grantee, the grantee's options include— i. Replacing the project director. The grantee must request written approval of the replacement from the NRCS administrative contact and must include the qualifications and the signature of the replacement signifying his or her willingness to serve on the project. ii. Subcontracting to the former project director's new organization. The grantee must request approval from the administrative contact to replace the project manager and retain the award, and to subcontract to the former project director's new organization certain portions of the project to be completed by the former project director. iii. Relinquishing the award. The grantee must submit to the NRCS administrative contact a signed letter by the grantee and the project director that indicates that the grantee is relinquishing the award. The letter must include the date the project director is leaving and a summary of progress to date. A final Standard Form (SF) 425 reflecting the total amount of funds spent by the recipient must be attached to the letter.

3. Transfers the award to his or her new organization, the authorized organization's representative at the new organization must submit the following to the NRCS administrative contact as soon as the transfer date is firm and the amount of funds to be transferred is known: i. The forms and certifications included in the application package ii. A project summary and work statement covering the work to be completed under the project (deliverables and objectives must be the same as those outlined in the approved proposal) iii. An updated qualifications statement for the project director showing his or her new organizational affiliation iv. Any cost-sharing requirements under the original award transfer to the new institution; therefore, cost-sharing information must be included in the proposal from the new organization

Note: The transfer of an award from one organization to another can take up to 90 calendar days to accomplish, which may result in a delay in the project director resuming the project at the new organization.

d. Budget Revisions.—Budget revisions will be in accordance with 2 CFR Part 200.308.

e. No-Cost Extensions of Time.—When a no-cost extension of time is required, the recipient must submit a written request to the NRCS administrative contact no later than 30 calendar days before the expiration date of the award. The request must contain the following: The length of additional time required to complete the project and a justification for the extension A summary of progress to date An estimate of funds expected to remain unobligated on the scheduled expiration date A projected timetable to complete the portions of the project for which the extension is being requested Signature of the grantee and the project director A status of cost sharing to date (if applicable)

Note: An extension will not exceed 12 months. Requests for no-cost extensions received after the expiration of the award will not be granted. V. PAYMENTS

a. Payment by NRCS to the entity will be made monthly or quarterly (whichever is mutually agreed upon by both parties) on a reimbursable or advanced basis upon completion of work outlined herein. Payment will be executed upon the submission of a properly executed form SF-270 with supporting documentation. The SF-270 must cite the agreement number, remittance address, and billing period. The SF-270 must be sent to the NRCS administrative contact at the email address identified in block 8 of the Notice of Grant/Agreement Award.

b. Unless otherwise specified in the award, the recipient must receive payments through electronic funds transfers.

c. Recipients requesting advances should request payments in amounts necessary to meet their current needs pursuant to procedures contained in the Federal administrative provisions and 31 CFR Part 205.

d. The method of payment between the recipient and its contractors will be in accordance with the policies and procedures established by the recipient except that the contractors may not use the USDA Office of Financial Management/National Finance Center method to request payments. If the grantee makes advance payments to contractors, the grantee must ensure that the timing of such payments is designed to minimize elapsed time between the advance payment and the disbursement of funds. Payment requests from the grantee's contractors will not be sent to NRCS for review or approval.

e. Accounting records for all costs incurred under this award must be supported by source documentation. Such documentation includes, but is not limited to, canceled checks, paid bills, payroll records, and subaward documents. Labor cost charges to this award must be based upon salaries actually earned and the time actually worked on this award. All project costs must be incurred within the approved project period of this award, including any approved no-cost extension of time. Costs that cannot be supported by source documentation or that are incurred outside of the approved project period and budget may be disallowed and may result in award funds being returned to the Federal Government by the recipient.

## VI. ACCRUALS

a. Recipients must submit an accrual estimate to the NRCS Program/Technical no later than 15 calendar days prior to the end of the quarter (submit by March 15, June 15, September 15 and December 15th). b. An accrual represents the value of goods or services provided to NRCS for which you have not requested payment. The quality and completeness of NRCS audited financial statements depends on your continuing cooperation and timely information. c. At a minimum, the signed accrual statement should include, "Under agreement number \_\_\_\_\_, at the close of the quarter ending \_\_\_\_\_, we have provided or anticipate providing goods or services that we have not requested payment for in the amount of \$\_\_\_\_\_." Include the name and title of the person preparing the accrual estimate.

## VII. FINANCIAL REPORTING

a. Recipients must submit a Federal Financial Report (FFR), SF 425 and 425A, in accordance with the following schedule:

Quarterly Schedule Report Due Date October 1 to December 31 January 31 January 1 to March 31 April 30 April 1 to June 30 July 31 July 1 to September 30 October 31

Reports must be submitted on an accrual accounting basis. Failure to submit reports in accordance with the above schedule may result in suspension or termination of award.

b. A final Report must be submitted no later than 90 calendar days after the completion of the award. For final FFRs, reporting end date must be the end date of the project or agreement period. The reports should be submitted to the NRCS administrative contact identified in award notifications.

## VIII. PERFORMANCE MONITORING AND REPORTING

- a. The recipient is responsible for monitoring day-to-day performance and for reporting to NRCS. If the project involves subaward arrangements, the recipient is also responsible for monitoring the performance of project activities under those arrangements to ensure that approved goals and schedules are met.
  - b. Every 6 months the recipient must submit a written progress report. Each report must cover— 1. A comparison of actual accomplishments with the goals and objectives established for the reporting period and, where project output can be quantified, a computation of the costs per unit of output.
2. The reasons why goals and objectives were not met, if appropriate.
  3. Additional pertinent information including, where appropriate, analysis and explanation of cost overruns or high unit cost.
- c. The recipient must submit a final performance report within 90 calendar days after completion of project.

#### IX. AUDIT REQUIREMENTS

The recipient is responsible for complying with audit requirements in accordance with 2 CFR 200, Subpart F. A non-Federal entity that expends \$750,000 or more during the non-Federal entity's fiscal year in Federal awards must have a single or program-specific audit conducted for that year.

#### X. SPECIAL PROVISIONS

- a. The recipient assures and certifies that it will comply with the minimum-wage and maximum- hour provisions of the Federal Fair Labor Standards Act.
- b. Employees of NRCS will participate in efforts under this agreement solely as representatives of the United States. To this end, they may not participate as directors, officers, employees, or otherwise serve or hold themselves out as representatives of the recipient. They also may not assist the recipient with efforts to lobby Congress or to raise money through fundraising efforts. Further, NRCS employees must report to their immediate supervisor any negotiations with the recipient concerning future employment and must refrain from participation in efforts regarding such parties until approved by the agency.
- c. Employees of the recipient will not be considered Federal employees or agents of the United States for any purposes under this agreement.

#### XI. PATENTS, INVENTIONS, COPYRIGHTS, AND ACKNOWLEDGMENT OF SUPPORT AND DISCLAIMER

- a. Allocation of rights of patents, inventions, and copyrights must be in accordance with 2 CFR Part 200.315. This regulation provides that small businesses normally may retain the principal worldwide patent rights to any invention developed with USDA support.
- b. In accordance with 37 CFR Section 401.14, each subject invention must be disclosed to the Federal agency within 2 months after the inventor discloses it in writing to contractor personnel responsible for patent matters. Invention disclosure statements pursuant to 37 CFR Section 401.14(c) must be made in writing to:  
  
Acquisitions Division Grants and Agreements Services Branch 1400 Independence Avenue, SW. Room 6823 South Building Washington, DC 20250
- c. USDA receives a royalty-free license for Federal Government use, reserves the right to require the patentee to license others in certain circumstances, and requires that anyone exclusively licensed to sell the invention in the United States must manufacture it domestically.
- d. The following acknowledgment of NRCS support must appear in the publication of any material, whether copyrighted or not, and any products in electronic formats (World Wide Web pages, computer programs, etc.) that is substantially based upon or developed under this award:

• "This material is based upon work supported by the Natural Resources Conservation Service, U.S. Department of Agriculture, under number [recipient should enter the applicable award number here]."

In addition, all publications and other materials, except scientific articles or papers published in scientific journals, must include the following statement:

• "Any opinions, findings, conclusions, or recommendations expressed in this publication are those of the author(s) and do not necessarily reflect the views of the U.S. Department of Agriculture."

e. All publications printed with Federal Government funds will include the most current USDA nondiscrimination statement, available from the Public Affairs Division, Civil Rights Division, or on the USDA and NRCS home pages. If the material is too small to permit the full nondiscrimination statement to be included, the material must, at a minimum, include the statement:

• "USDA is an equal opportunity provider and employer." Any publication prepared with funding from this agreement must include acknowledgement to USDA, Natural Resources Conservation Service."

The recipient is responsible for ensuring that an acknowledgment of NRCS is made during news media interviews, including popular media such as radio, television, and news magazines, that discuss in a substantial way work funded by this award.

## XII. COST-SHARING REQUIREMENTS

a. If the award has specific cost-sharing requirements, the cost-sharing participation in other projects may not be counted toward meeting the specific cost-share requirement of this award, and must come from non-Federal sources unless otherwise stated in the applicable program announcement.

b. Should the recipient become aware that it may be unable to provide the cost-sharing amount identified in this award, it must— 1. Immediately notify the NRCS administrative contact of the situation. 2. Specify the steps it plans to take to secure replacement cost sharing. 3. Indicate the plans to either continue or phase out the project in the absence of cost sharing.

c. If NRCS agrees to the organization's proposed plans, the recipient will be notified accordingly. If the organization's plans are not acceptable to NRCS, the award may be subject to termination. NRCS modifications to proposed cost sharing revisions are made on a case-by-case basis.

d. Failure by the recipient to notify NRCS in accordance with paragraph (b) above may result in the disallowance of some or all the costs charged to the award, the subsequent recovery by NRCS of some of the NRCS funds provided under the award, and possible termination of the award, and may constitute a violation of the terms and conditions of the award so serious as to provide grounds for subsequent suspension or debarment.

e. The recipient must maintain records of all project costs that are claimed by the recipient as cost sharing as well records of costs to be paid by NRCS. If the recipient's cost participation includes in-kind contributions, the basis for determining the valuation for volunteer services and donated property must be documented.

## XIII. PROGRAM INCOME

Income derived from patents, inventions, or copyrights will be disposed of in accordance with the recipient's own policies. General program income earned under this award during the period of NRCS support must be added to total project funds and used to further the purpose and scope of this award or the legislation under which this award is made.

## XIV. NONEXPENDABLE EQUIPMENT

Recipients purchasing equipment or products with funds provided under this award are encouraged to use such funds to purchase only American-made equipment and products. Title to nonexpendable equipment purchased with award funds will vest in the recipient upon completion of the award project and acceptance by NRCS of required final reports. When equipment is no longer needed by the recipient and the per-unit fair market value is less than \$5,000, the recipient may retain, sell, or dispose of the equipment with no further obligation to NRCS. However, if the per-unit fair market value is \$5,000 or more, the recipient must submit a written request to the NRCS administrative contact for disposition instructions.

## XV. LIMIT OF FEDERAL LIABILITY

The maximum financial obligation of NRCS to the recipient is the amount of funds indicated in the award as obligated by NRCS. However, in the event that an erroneous amount is stated on the approved budget, or any supporting document relating to the award, NRCS will have the unilateral right to make the correction and to make an appropriate adjustment in the NRCS share of the award to align with the Federal amount authorized.

## XVI. MODIFICATIONS AND TERMINATIONS

NRCS may amend or modify the award through an exchange of correspondence between authorized officials of the recipient and NRCS. The award is subject to termination if NRCS determines that the recipient has failed to comply with the terms and conditions of the award. In the event that the award is terminated, the financial obligations of the parties

will be those set forth in 2 CFR Part 200.339.

#### XVII. AWARD CLOSEOUT

Award closeout is the process by which NRCS determines that all required project activities have been performed satisfactorily and all necessary administrative actions have been completed.



# CONSENT AGENDA ITEM 305

CITY COMMISSION REVISED AGENDA  
AUGUST 12, 2019 | REGULAR MEETING

## TITLE

Resolution 2019-18 - Agreement with Traffic Technology Services, Inc. to Access Traffic Signal Data

## SUMMARY

Through an Interlocal Agreement, Seminole County maintains all of the City of Winter Springs traffic signals on the City's behalf.

Seminole County and Traffic Technology Services (TTS) have entered into an agreement which allows for the use of real-time traffic signal data for connected vehicle applications. These applications provide the foundation for a safe connected and automated future while providing information in vehicles for more compliant drivers at signalized intersections. Audi vehicles have been providing this information for the past few years, along with more vehicle manufacturers and potential 3rd party devices/applications in the near future. The TTS software only provides real-time signal phasing and timing data to properly equipped vehicles. This software does not have the capability to provide traffic volume data.

In order for TTS to complete its due diligence process, they need to indemnify each owner of the signalized intersection. They cannot provide it inside vehicles until they take the liability on themselves. This takes place in the form of a data authorization agreement. The attached agreement provides for such authorization and indemnification of the City of Winter Springs. The Florida Department of Transportation and Seminole County have already authorized TTS to operate through a similar agreement.

Resolution 2019-18 will allow for approval and authorization to execute the attached Agreement. This will have no financial impact to the City of Winter Springs.

## RECOMMENDATION

Staff recommends the City Commission approve Resolution 2019-18 to authorize the City Mayor and City Attorney to sign Resolution 2019-18 and an agreement with Traffic Technology Services, Inc.



**RESOLUTION NO. 2019-18**

**A RESOLUTION OF THE CITY COMMISSION OF THE CITY OF WINTER SPRINGS, FLORIDA; APPROVING AND AUTHORIZING THE EXECUTION OF AN AGREEMENT WITH TRAFFIC TECHNOLOGY SERVICES, INC. FOR ACCESS TO TRAFFIC SIGNAL DATA; PROVIDING FOR CONFLICTS, SEVERABILITY, AND EFFECTIVE DATE.**

**WHEREAS**, the City of Winter Springs (“City”) is committed to improving the mobility and safety of its residents and visitors; and

**WHEREAS**, Traffic Technology Services, Inc. (“TTS”) is in the business of developing technologies, strategies, and systems for use in maximizing the efficiency of transportation end users and thus the overall capacity of existing transportation networks; and

**WHEREAS**, the City, in cooperation with Seminole County, collects real time traffic signal data and other related data; and

**WHEREAS**, TTS has a significant business interest to access real time traffic signal data as the input into its proprietary and patented processes and desires to gain access to the City’s traffic signal data; and

**WHEREAS**, these City’s traffic signal data may be made available to TTS at minimal or no cost to the City; and

**WHEREAS**, these City’s traffic signal data are not confidential, nor identify any transportation end user specifically in any manner; and

**WHEREAS**, TTS has requested to enter into an Agreement with the City to allow access to traffic signal data; and

**WHEREAS**, TTS agrees to provide related inventories, signal performance metrics, and other formatted data products to the City in exchange for access to these real time traffic signal data; and

**WHEREAS**, the City agrees to provide TTS with real time traffic signal data; and

**WHEREAS**, City staff has reviewed the Agreement with TTS and finds it favorable to meet the needs of the City.

**NOW, THEREFORE, BE IT RESOLVED BY THE CITY COMMISSION OF THE CITY OF WINTER SPRINGS, SEMINOLE COUNTY, FLORIDA, AS FOLLOWS:**

**Section 1.** The City Commission of the City of Winter Springs hereby approves the Agreement with Traffic Technology Services, Inc. Attached hereto and authorizes the Mayor to

execute said document on behalf of the City.

**Section 2. Repeal of Prior Inconsistent Resolutions.** All prior resolutions or parts of resolutions in conflict herewith are hereby repealed to the extent of the conflict.

**Section 3. Severability.** If any section, subsection, sentence, clause, phrase, word, or portion of this Resolution is for any reason held invalid or unconstitutional by any court of competent jurisdiction, such portion shall be deemed a separate, distinct and independent provision and such holding shall not affect the validity of the remaining portion hereto.

**Section 4. Effective Date.** This Resolution shall become effective immediately upon adoption by the City Commission of the City of Winter Springs, Florida.

**RESOLVED** by the City Commission of the City of Winter Springs, Florida, in a regular meeting assembled on the 8th day of July, 2019.

---

**Charles Lacey, Mayor**

ATTEST:

---

**Andrea Lorenzo-Luaces, City Clerk**

Approved as to legal form and sufficiency for  
the City of Winter Springs only:

---

**Anthony A. Garganese, City Attorney**



**THIS DISCLOSURE AGREEMENT** (“Agreement”) is an agreement between the City of Winter Springs, FL (“Agency”) and Traffic Technology Services, Inc. (“TTS”). Both the Agency and TTS are sometimes referred in this Agreement together as “Parties”.

**WHEREAS**, TTS has requested Agency provide traffic signal data (“Signal Data”) to include signal status and states, demand status and states, and other information such as traffic signal timing parameters and plan information available from traffic signal controllers or an Advanced Traffic Management System (“ATMS”), and;

**WHEREAS**, Agency has ownership or right-of-way of the infrastructure where TTS requests Signal Data, and;

**WHEREAS**, TTS has executed an agreement with the maintaining agency, Seminole County, FL, (“Maintainer”) for the Agency, and;

**WHEREAS**, TTS has a business partnership with the ATMS vendor who requires this agreement to perform services for Agency ATMS on behalf of TTS, and;

**WHEREAS**, Agency has agreed to share the Signal Data with TTS upon certain terms and conditions, and;

**WHEREAS**, TTS has agreed to share data with Agency from customer applications.

Now therefore, in consideration of the recitals, Agency and TTS agree as follows:

1. Agency will provide TTS with Signal Data. TTS will work with Maintainer to obtain Signal Data in the most efficient and non-intrusive manner from Maintainer, which may include access to Agency’s systems.
2. Agency provides no warranties express or implied, concerning the accuracy, correctness, completeness, or permanence of the Signal Data and further expresses no warranty regarding uninterrupted transmission of the Signal Data. TTS agrees to independently verify the accuracy, correctness, or completeness of the Signal Data. The Agency reserves the right to immediately discontinue the Agency’s Signal Data stream without notice and at the Agency’s discretion upon evidence of tampering or other unauthorized interference with the Agency’s data or facilities.
3. Signal Data remain the property of Agency and it shall not be copied, reproduced, or transferred (directly or indirectly) without the express written permission of Agency.
4. TTS will be responsible for any and all costs associated with making the Signal Data available, including any system modifications or vendor costs associated with Agency’s ATMS vendor.
5. TTS accepts full responsibility for all work related thereto and agrees to indemnify, defend and hold harmless Agency and its elected officials, employees, agents and attorneys from any liability, cost or expense whatsoever arising from or related to the use of or reliance upon Signal Data including, but not limited to, any breach of TTS’ representations and warranties; any personal injury, death or property damage caused by any alleged act, omission, error, fault, mistake or negligence of TTS, its employees, agents, or representatives in connection with or incident to TTS’ performance under or related to this Agreement, regardless of any concurrent negligence of Agency; or the infringement of any patent, copyright, trademark, trade secret or other proprietary right of any third party by TTS’ use of the Signal Data provided under this Agreement.

TTS specifically assumes potential liability for actions brought by TTS’ own employees against the Agency and, solely for the purpose of this indemnification and defense, TTS specifically waives its entitlement, if any, to immunity under Section 440.11, Florida Statutes, or its applicable worker’s compensation statute. This waiver has been specifically and mutually negotiated by the parties.



The Agency assumes no responsibility for any equipment or property placed in the Agency's signal system and/or ATMS system facility and TTS hereby expressly relieves and discharges the Agency from any and all liability for any loss, injury, or damage to persons and property that may be sustained by reason of the use or occupancy of the Agency facility. TTS agrees to approval by the Agency prior to placement of any equipment or property placed in the Agency's signal system and/or ATMS system facility. TTS agrees to immediately remove or relocate, at its sole expense, any or all of the equipment, hardware, or software at the request of the Agency. TTS shall provide a fully trained contact person who is solely responsible for the operation and maintenance of any TTS equipment and all activities associated with this Agreement. The Agency shall have no responsibility to provide any training or supervision of the TTS contact person associated with this Agreement other than to allow the contact person to attend all briefings and/or training sessions provided by the Agency which relate to the equipment, hardware or software.

TTS agrees it will not install or operate any equipment, hardware or software that may interfere with the Agency's communications equipment or other Agency electronic systems. In the event any such interference occurs, TTS shall immediately remedy all problems caused by such interference. TTS further authorizes the Agency to disconnect or deactivate any equipment, hardware or software causing such interference and waives any claim it might otherwise assert as a result of such disconnection or deactivation.

6. TTS shall procure and maintain insurance required under this Section at TTS' own cost.
  - a. TTS shall provide Agency with a Certificate of Insurance on a current ACORD Form signed by an authorized representative of the insurer evidencing the insurance required by this Section (Professional Liability, Workers' Compensation/Employer's Liability, Commercial General Liability, and Business Auto). The Certificate of Insurance must identify this Agreement clearly on its face. The Agency, its officials, officers and employees must be named as additional insured under the Commercial General Liability policy. If the policy provides for a blanket additional insured coverage, TTS shall provide a copy of the section of the policy along with the Certificate of Insurance. If the coverage does not exist, the policy must be endorsed to include the additional insured verbiage. The Certificate of Insurance must provide that Agency will be given, by policy endorsement, not less than thirty (30) days written notice prior to the cancellation or non-renewal or by a method acceptable to the Agency. Until such time as the insurance is no longer required to be maintained by TTS, TTS shall provide the Agency with a renewal or replacement Certificate of Insurance before expiration or replacement of the insurance for which a previous Certificate of Insurance has been provided.
  - b. In addition to providing the Certificate of Insurance on a current ACORD Form, upon request as required by the Agency, TTS shall provide the Agency with a certified copy of each of the policies of insurance providing the coverage required by this Section within thirty (30) days after receipt of the request for such certified copy. Certified copies of policies may only be provided by the insurer, not the agent/broker.
  - c. Neither approval by the Agency nor failure to disapprove the insurance furnished by TTS will relieve TTS of its full responsibility for performance of any obligation including TTS' indemnification of the Agency under this Agreement.
  - d. Insurance companies providing the insurance under this Agreement must meet the following requirements:
    - i. Companies issuing policies must be authorized to conduct business in the State of Florida and prove same by maintaining Certificates of Authority issued to the companies by the Florida Office of Insurance Regulation.
    - ii. In addition, such companies must have and maintain, at a minimum, a Best's Rating of "A-" and a minimum Financial Size Category of "VII" according to A.M. Best Company.
    - iii. If, during the period which an insurance company is providing the insurance coverage required by this Agreement, an insurance company: (i) loses its Certificate of Authority; or (ii) fails to maintain the requisite Best's Rating and Financial Size Category, TTS shall, as soon as it has knowledge of any such circumstance, immediately notify the Agency and immediately replace the insurance coverage provided by the insurance company with a different insurance company meeting the requirements of this Agreement. Until such time as



TTS has replaced the unacceptable insurer with an insurer acceptable to Agency, TTS will be deemed to be in default of this Agreement.

- e. Without limiting any of the other obligations or liability of TTS, TTS shall, at its sole expense, procure, maintain, and keep in force amounts and types of insurance conforming to the minimum requirements set forth in this subsection. Except as otherwise specified in this Agreement, the insurance must become effective upon execution of this Agreement by TTS and must be maintained in force until the expiration of this Agreement's term or the expiration of all work orders issued under this Agreement, whichever comes first, Failure by TTS to maintain insurance coverage within the stated period and in compliance with insurance requirements of TTS will constitute a material breach of this Agreement, for which this Agreement may be immediately terminated by Agency. The amounts and types of insurance must conform to the following minimum requirements:

- i. Commercial General Liability. TTS' insurance must cover it for those sources of liability that would be covered by the latest edition of the standards Commercial General Liability Coverage Form (ISO Form CG 00 01), as filed for use in the State of Florida by the Insurance Services Office Coverage must not contain any endorsements excluding or limiting Products/Completed Operations, Contractual Liability, or Separation of Insureds. The minimum limits to be maintained by TTS (inclusive of any amounts provided by an Umbrella or Excess Policy) are as follows:

General Aggregate      Two Times (2x) the Each Occurrence Limit  
 Personal & Advertising Injury Limit      \$1,000,000.00  
 Each Occurrence Limit      \$1,000,000.00

- ii. Cyber Liability Insurance. Information Security/Cyber Liability Insurance must include: Internet Media Liability including cloud computing and mobile devices, for protection of private or confidential information whether electronic or non-electronic, network security and privacy; privacy against liability for system attacks, digital asset loss, denial or loss of service, introduction, implantation or spread of malicious software code, security breach, unauthorized access and use; including regulatory action expenses; and notification and credit monitoring expenses with at least the minimum limits listed below.

Each Occurrence	\$2,000,000.00
Network Security/Privacy Liability	\$2,000,000.00
Breach Response/Notification Sublimit	A minimum limit of 50% of the policy
	Aggregate
Technology Products E&O	\$2,000,000.00

Coverage must be maintained in effect during the period of the Agreement and for not less than two (2) years after termination or completion of the Agreement. Information/Cyber Liability Insurance must be written on a "claims-made" basis covering TTS, its employees, subcontractors and agents for expenses, claims and losses resulting from wrongful acts committed in the performance of, or failure to perform, all services under this Agreement, including, without limitation, claims, demand and any other payments related to electronic or physical security, breaches of confidentiality and invasion of or breaches of privacy.

- f. The insurance provided by TTS pursuant to this Agreement must apply on a primary and non-contributory basis and any other insurance or self-insurance maintained by the Agency or Agency's officials, officers, or employees will be in excess of, and not contributing to, the insurance provided by or on behalf of TTS.
- g. The Commercial General Liability and the Umbrella policy required by this Agreement must be provided on an occurrence rather than a claims-made basis.
- h. All policies must be endorsed to provide a Waiver of Subrogation clause in favor of the agency and its respective officials, officers and employees. This Waiver of Subrogation requirement does not apply to any policy that includes a condition that specifically prohibits such an endorsement or voids



coverage if the Named Insured enter into such an agreement on a pre-loss basis.

- i. Compliance with the foregoing insurance requirements does not relieve TTS, its employees or its agents of liability from any obligation under a Section or any other portion of this Agreement.
7. TTS agrees to make available vehicle-based performance metrics and signal performance metrics reports to the City in exchange for access to Signal Data. TTS agrees that it shall provide to the Agency login access to a website where the metrics will updated monthly. The Agency shall be able to run specific queries and generate the metrics reports based on the queries submitted. Vehicle-based performance metrics reports may, to the extent available, provide information regarding vehicle delay (average and total), percentage of split failures, average speed, and traffic volumes. Signal performance metrics report may provide information regarding traffic signal cycle lengths, green time during cycles, pedestrian cycle lengths and wait times, and vehicle wait times.
8. If any provision of this Agreement is invalid or unenforceable, then such provision shall be construed and limited to the extent necessary, or severed if necessary, in order to eliminate such invalidity or unenforceability, and the other provisions of this Agreement shall not be affected thereby.
9. No delay or omission by either party in exercising any rights under this Agreement shall operate as a waiver of that or any other right. A waiver or consent given by either party on any one occasion is effective only in that instance and shall not be construed as a bar to or waiver of any right on any other occasion.
10. Neither party may assign this Agreement or any of its rights or obligations under this Agreement, without the prior written approval of the other party, which shall not be unreasonably withheld. Any attempted assignment, delegation, or transfer without the necessary approval shall be void.
11. This Agreement is governed by and will be construed in accordance with the laws of the State of Florida. Venue for any action shall be properly placed only in Seminole County, Florida for state court actions and Orlando, Florida for federal court actions.
12. This Agreement is the entire agreement between the Parties with respect to the subject matter contained herein and supersedes all prior or contemporaneous oral or written agreements concerning this subject matter.
13. This Agreement will begin on the latest date below (“Effective Date”) and continue until terminated in writing by either party for any reason.
14. This Agreement may be executed by the Parties in identical counterparts, all of which together shall constitute the final agreement. Executed counterparts may be exchanged by facsimile or electronic transmission.
15. Pursuant to Chapter 119, Florida Statutes, TTS agrees that any records, documents, transactions, writings, papers, letters, computerized information and programs, maps, books, audio or video tapes, films, photographs, data processing software, writings or other material(s), regardless of the physical form, characteristics, or means of transmission, of TTS related, directly or indirectly, to the services provided to the City under this Agreement and made or received pursuant to law or ordinance or in connection with the transaction of official business by the Agency, may be deemed to be a public record, whether in the possession or control of the Agency or TTS. Said records, documents, transactions, writings, papers, letters, computerized information and programs, maps, books, audio or video tapes, films, photographs, data processing software, writings or other material(s), regardless of the physical form, characteristics, or means of transmission of TTS are subject to the provisions of Chapter 119, Florida Statutes, and may not be destroyed without the specific written approval of the Agency’s designated custodian of public records. Upon request by the Agency, TTS shall promptly supply copies of said Public Records to the Agency. All books, cards, registers, receipts, documents, and other papers in connection with this Agreement shall at any and all reasonable times during normal business hours of TTS be open and freely exhibited to the City for the purpose of examination and/or audit. Failure by TTS to grant such access and comply with public records laws and/or requests shall be grounds for immediate unilateral cancellation of this Agreement by the Agency upon delivery of a written notice of cancellation. If TTS fails to comply with this Section, and the Agency must enforce this Section, or the Agency suffers a third party award of attorney’s fees and/or damages for violating Chapter 119, Florida Statutes, due to TTS’s failure to comply with this Section, the Agency shall collect from TTS prevailing party attorney’s fees and costs, and any damages incurred by the Agency, for enforcing this Section against TTS. And, if applicable, the Agency shall also be entitled to reimbursement of all attorneys’ fees and damages which the Agency had to pay a third party because of TTS’s failure to comply with this Section. The terms and conditions set forth in this Section shall survive the termination of this Agreement.





IN WITNESS OF THIS, the Parties hereby execute this Agreement through their authorized representatives.

\_\_\_\_\_  
Authorized Signature (Agency)

\_\_\_\_\_  
Authorized Signature (TTS)

\_\_\_\_\_  
Name / Title

\_\_\_\_\_  
Name / Title

\_\_\_\_\_  
Date

\_\_\_\_\_  
Date



# Traffic Technology Services Data Dashboards





# Agenda

- TTS' work in Florida
- TTS' Signal Data Dashboards
- Use cases of Data



# TTS Overview

- Information provider for connected and automated vehicles
  - Cloud-based, dynamic traffic control data
  - Industry standard product
  - Global product offerings
- Virtualization of infrastructure
  - Prediction of dynamic states for traffic signal control
  - Additional “digital infrastructure” products forthcoming
- Product maturity
  - Testing, proof of concepts completed in 2013-2014
  - Commercial service launched with OEM product in 2016
    - Audi connect® Traffic Light Information
- Global footprint
  - North American product deployments
  - European R&D projects

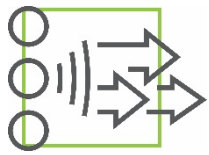

# Data Flow – Direct to Customer

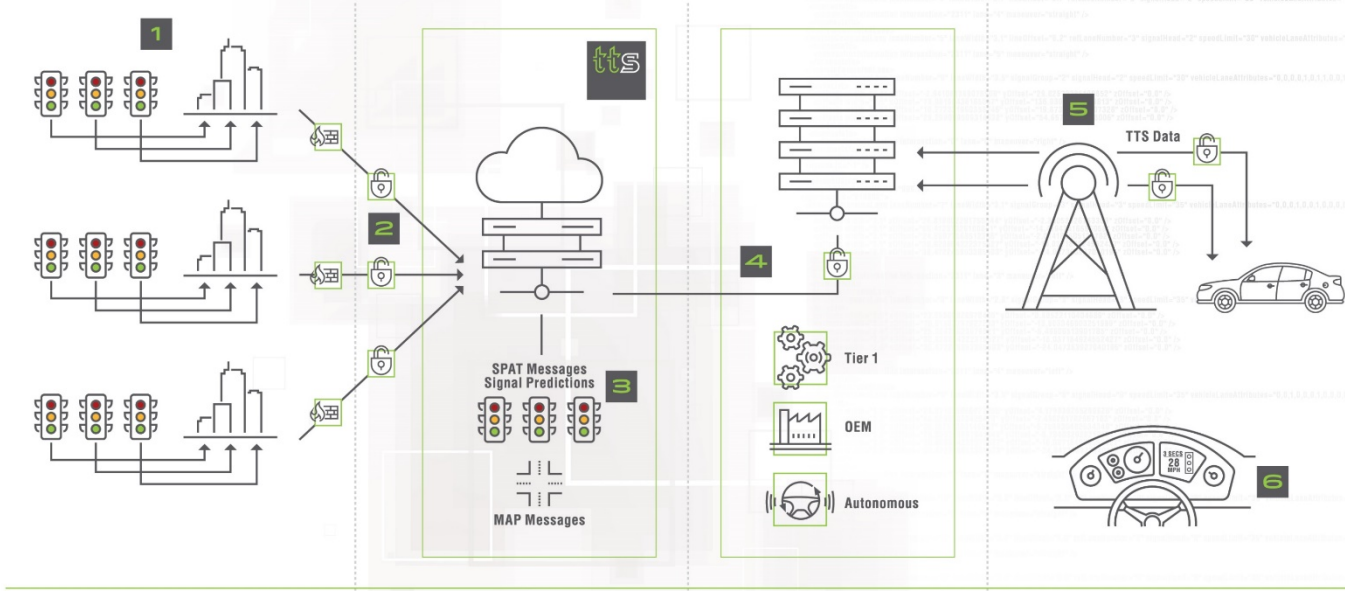

- 1** Agency/Region provides real time traffic signal data, as-built drawings, and signal timing plan information
- 2** Data feed from ATMS to TTS cloud-based servers via web service
- 3** Develop SAE J2735 MAP and SPAT messages for each traffic signal location
- 4** Deliver all messages to customer backend system
- 5** Customer manages vehicle heading, maneuver, and geolocation and returns targeted MAP and SPAT content to vehicle
- 6** Information displayed to end user for relevant connected and automated vehicle applications

[trafficechservices.com](http://trafficechservices.com)





# Seminole County Deployment

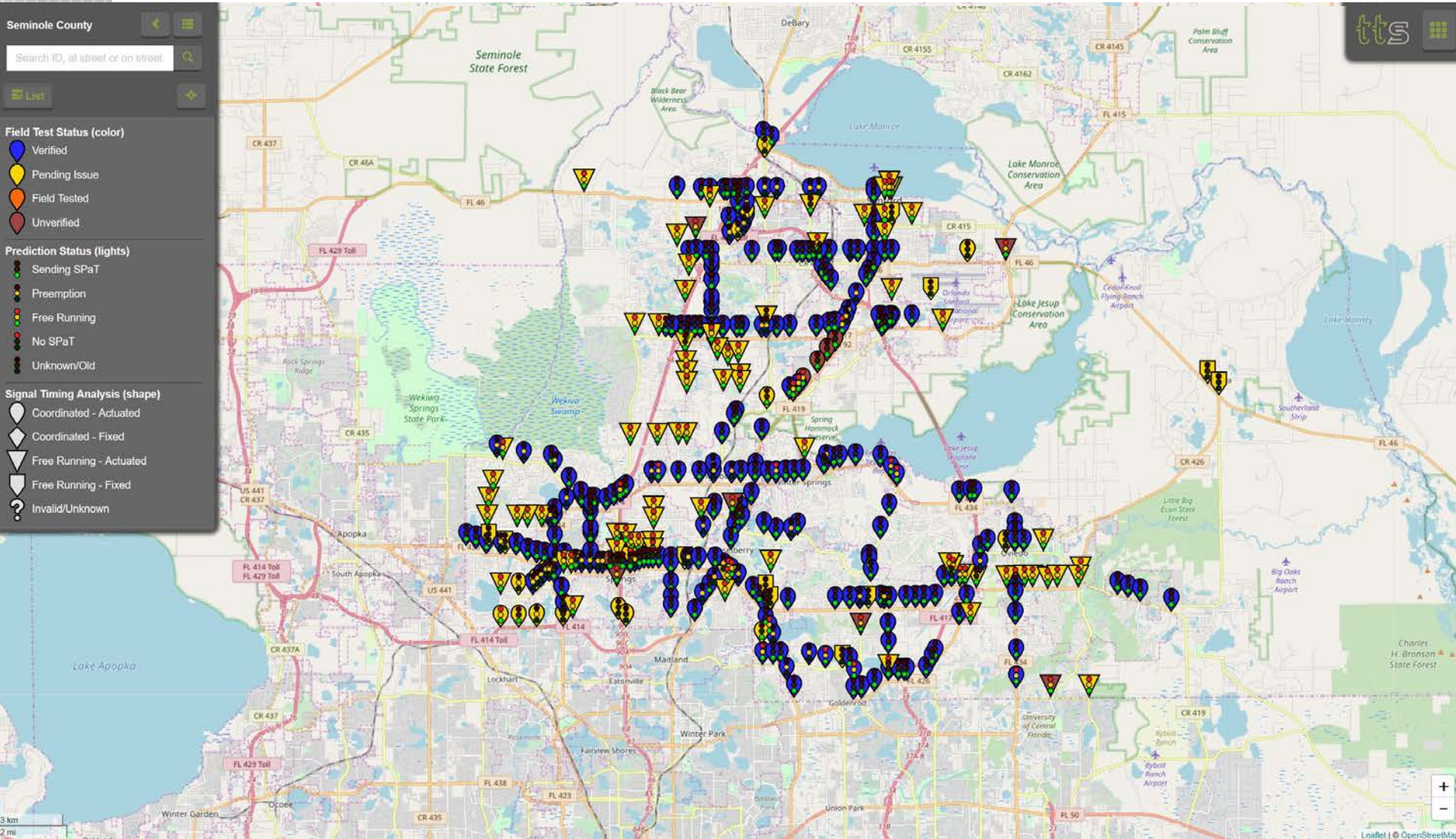





# Beyond Connected Vehicle Service...

- Added-service beyond our projects with OEMs to provide our agency suppliers with useful metrics
- TTS, per the Florida DOT Data Authorization agreement, shall provide
  - “Reports of vehicle-based performance metrics...freely-available without restriction for use by the DEPARTMENT and local partners.”
- Data includes Signal Performance Metrics (SPMs) and Vehicle Performance Metrics (VPMs)



# Why are we doing SPMs?

- Partnership models are key to transportation technology advancement
- No stepping stone to full ATSPM
- Formatted & cleaned ATMS-level data can provide additional insights



# SPM Introduction

- TTS prepares dashboards of Signal Performance Measures to share back with our public agency suppliers
- Currently developing samples for Las Vegas, NV
- SPM data to become available on a regular basis by end of 2019
- TTS will create dashboards for all of our supplier agencies as data becomes available

# Data Flow

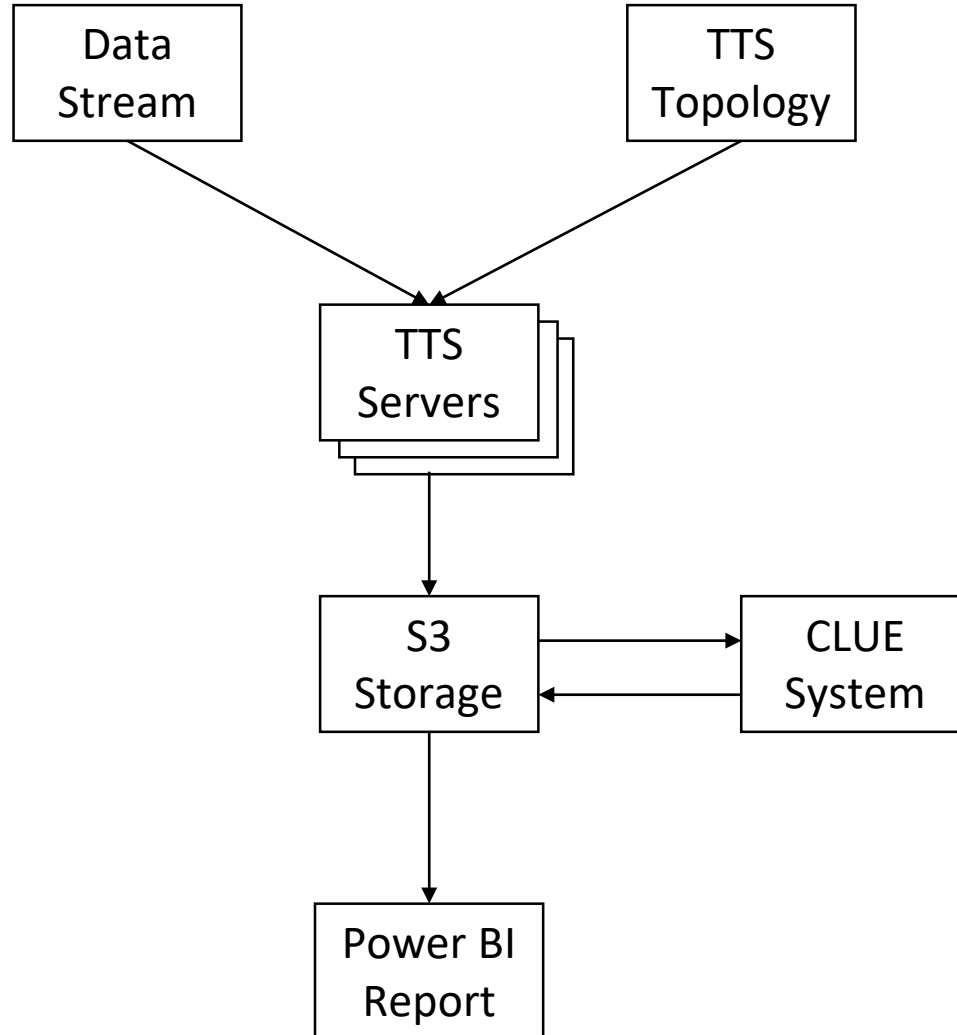

# SPM – Signal Data

- Types of signal data include:
  - Background Cycle Length
  - Green Time
  - Pedestrian Cycle
  - Max Ped Wait Time
  - Preempt Duration
  - Average Duration of Green per Cycle
  - Phase Skip Frequency
  - Max Vehicle Wait Time



# Traffic Signal SPM Data

- Signal Timing Plan Based
- Signal Phase Based
- System Analytics
  - Daily
  - Timeline





# SPM and System Analytics Data



Data Sources:  
Audi of America, LLC  
RTC - FAST

## Traffic Technology Services Signal Intelligence Report

prepared for



RTC - FAST

with data between

November 1, 2018 - November 7, 2018

Number of Signals Included: 1156

Cover Page

Signal Timing Plans - SPM

Signal Phases - SPM

System Analytics - Daily

System Analytics - Timeline

## Sample for Las Vegas, NV (1156 Intersections, 1 week)



# SPM Data

- Signal Timing Plan Based



# SPM Data – Plan Based



## Signal Performance Measures

**Date Range**

**Date**

**Day of Week**

**Hour**

**Intersection N...**

**Operation**

**Plan**

**Intersection Search**

**Selected Int**

**Selected Signals**

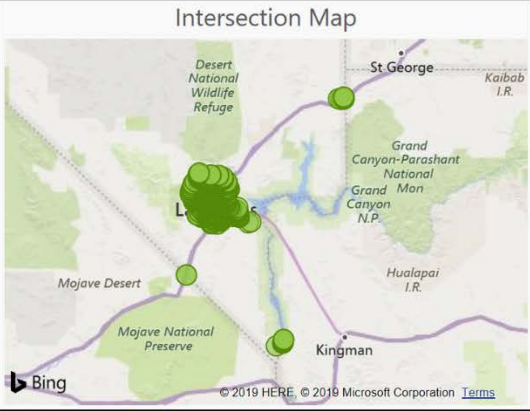

**224.0**  
Max Background Cycle Length

**3%**  
Preemption/Offset Seeking

**48%**  
Cycles with Peds

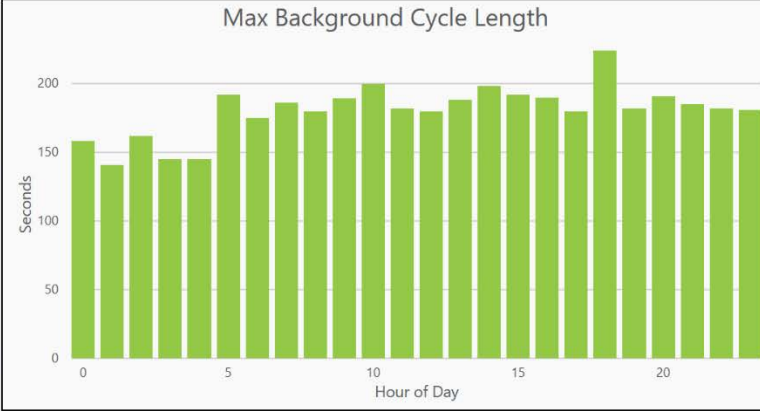

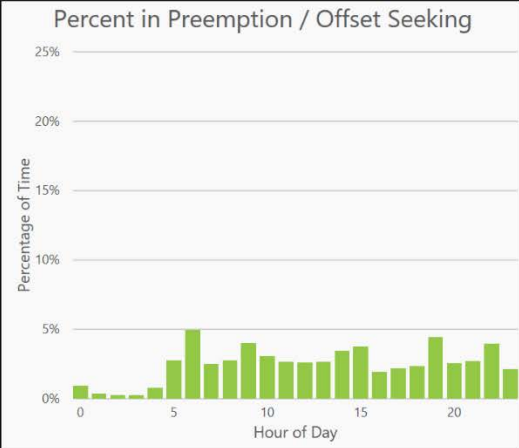

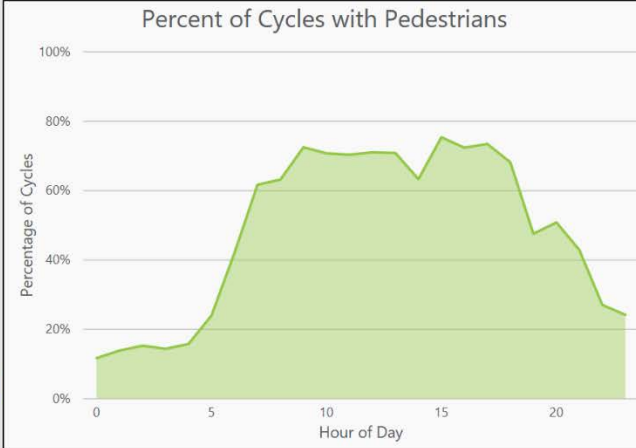

Cover Page
Signal Timing Plans - SPM
Signal Phases - SPM
System Analytics - Daily
System Analytics - Timeline

1156 intersections, November 1 – 7, 2018, All days, All times



# SPM Data – Plan Based (filtered)

## Signal Performance Measures

✦ ...

### Intersection Map

© 2019 HERE, © 2019 Microsoft Corporation

### Max Background Cycle Length

Hour of Day	Seconds
0	145
1	140
2	140
3	140
4	140
5	140
6	170
7	160
8	160
9	160
10	175
11	165
12	165
13	165
14	175
15	170
16	170
17	170
18	170
19	170
20	170
21	170
22	175
23	170
24	170

**180.0**

Max Background Cycle Length

**2%**

Preemption/Offset Seeking

**69%**

Cycles with Peds

### Percent in Preemption / Offset Seeking

### Percent of Cycles with Pedestrians

Date Range

11/1/2018

11/7/2018

Date

All

Day of Week

Multiple s...

Hour

Multiple s...

Intersection N...

All

Operation

All

Plan

All

Intersection Search

Las Vegas

Selected Int

- WELCOME SIGN
- 2514 - LAS VEGAS BLVD & CACTUS AVE
- 5131 - LAS VEGAS BLVD & DALE AVE
- 5167 - E Russell Rd & Las Vegas Expy
- 3037 - S Las Vegas Blvd & E Bridger Ave
- 3196 - 4TH ST & LAS VEGAS BLVD
- 5161 - Las Vegas Fwy & W Horizon Dr

Selected Signals

**74**

Cover Page
Signal Timing Plans - SPM
Signal Phases - SPM
System Analytics - Daily
System Analytics - Timeline

74 intersections, Tue – Thurs (within November 1 – 7, 2018), 4-6 p.m.



# SPM Data

- Signal Phase Based



# SPM Data – Phase Based



## Signal Performance Measures

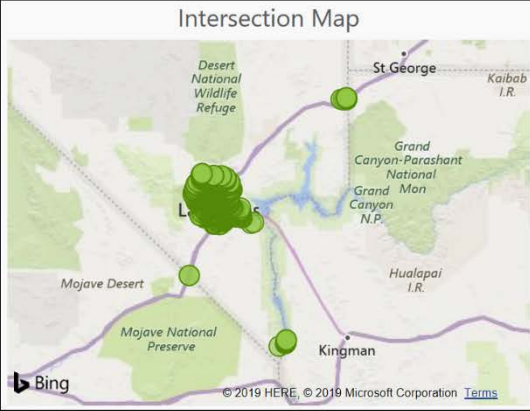

**40.2%**  
Green per Cycle

**39.2%**  
Phase Skip Frequency

**34**  
Avg Max Veh Wait (s)

**13**  
Avg Max Ped Wait (s)

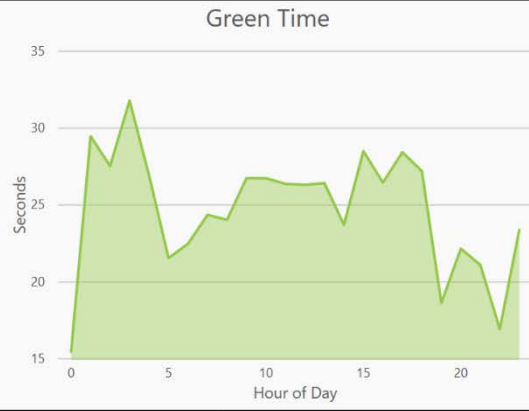

Green Time

Date Range

11/1/2018

11/7/2018

Date: All

Day of Week: All

Hour: All

Intersection N...: All

Operation: All

Plan: All

Phase: All

Intersection Search: Search

Selected Int: All Selected

Selected Signals: 1156

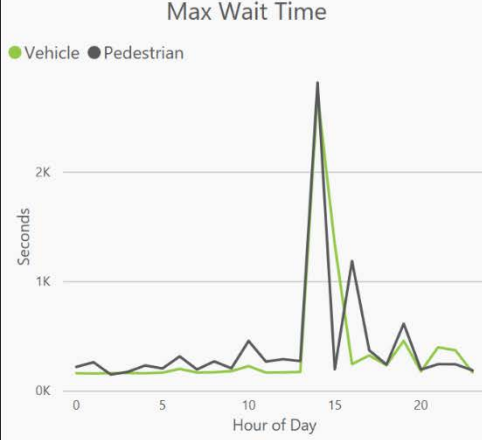

Max Wait Time

● Vehicle ● Pedestrian

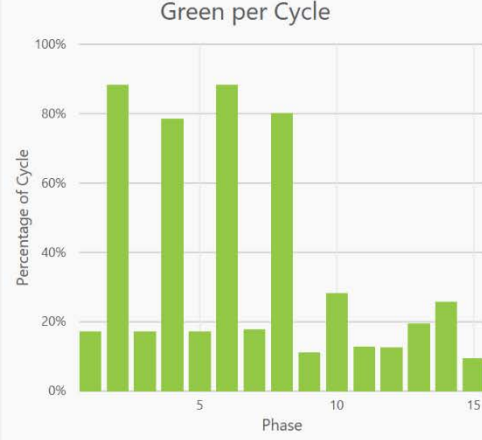

Green per Cycle

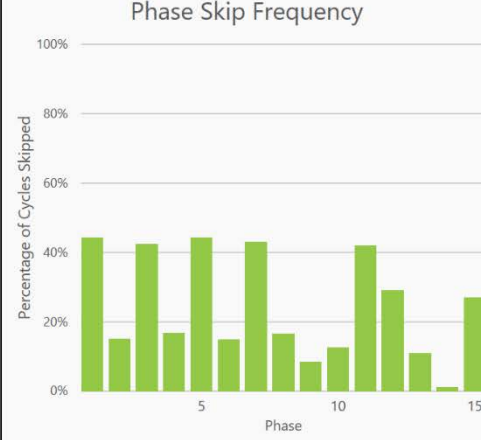

Phase Skip Frequency

Cover Page
Signal Timing Plans - SPM
Signal Phases - SPM
System Analytics - Daily
System Analytics - Timeline

1156 intersections, November 1 – 7, 2018, All days, All times





# SPM Data – Phase Based (filtered)



## Signal Performance Measures



**31.0%**  
Green per Cycle

**31.1%**  
Phase Skip Frequency

**41**  
Avg Max Veh Wait (s)

**15**  
Avg Max Ped Wait (s)

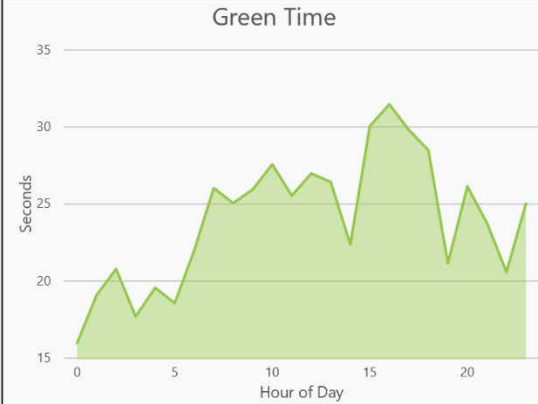

Date Range

11/1/2018  
11/7/2018

Date: All

Day of Week: Multiple s...

Hour: All

Intersection N...: All

Operation: All

Plan: All

Phase: All

Intersection Search: Vegas

Selected Int: VEGAS BLVD & DALE AVE

Selected Signals: 74

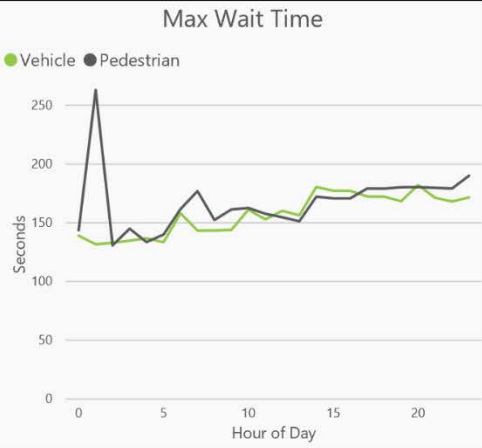

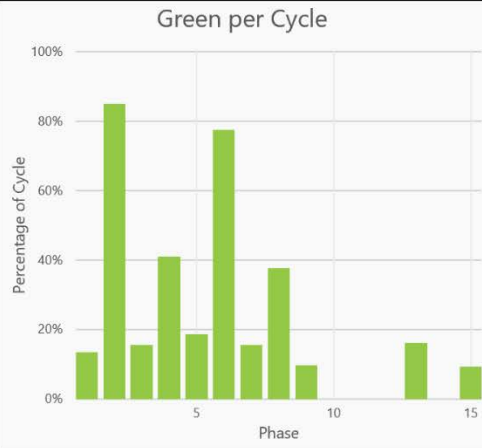

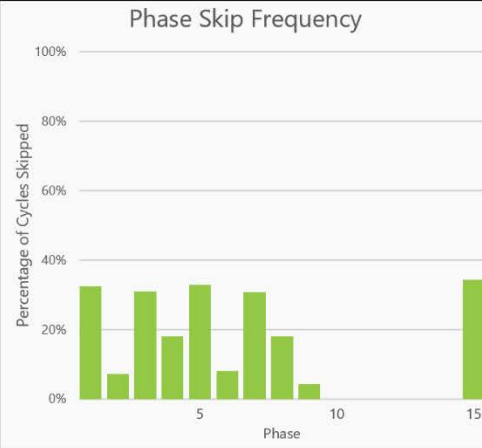

Cover Page
Signal Timing Plans - SPM
Signal Phases - SPM
System Analytics - Daily
System Analytics - Timeline

74 intersections, Tue – Thurs (within November 1 – 7, 2018), All times



# SPM Data

- System Analytics - Daily



# System Analytics - Daily



## System Analytics

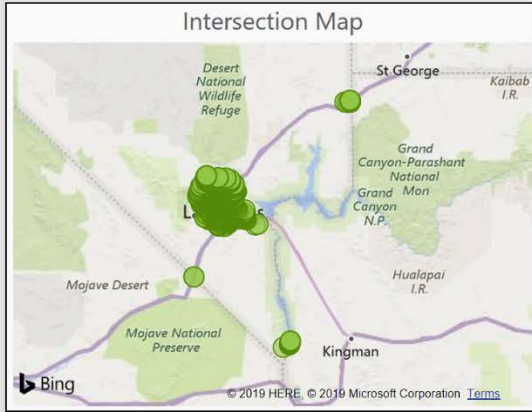

58% Data Connectivity  
 2% High Latency Data  
 39% Product Delivery  
 270,304,151 Product Delivery

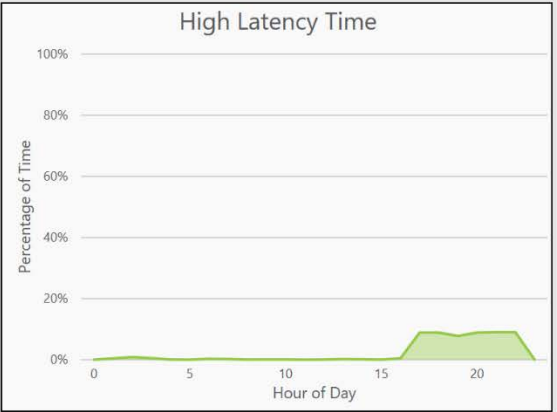

**Date Range**  
 11/1/2018  
 11/7/2018

**Date**  
 All

**Day of Week**  
 All

**Hour**  
 All

**Intersection N...**  
 All

**Operation**  
 All

**Plan**  
 All

**Intersection Search**  
 Search

**Selected Int**  
 All Selected

**Selected Signals**  
 1156

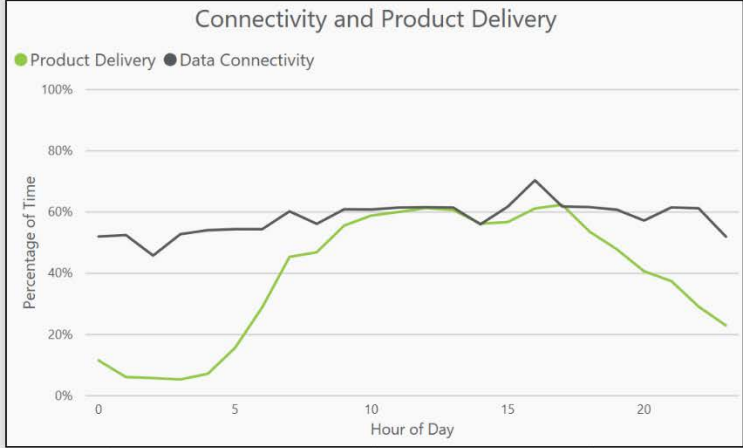

- Cover Page
- Signal Timing Plans - SPM
- Signal Phases - SPM
- System Analytics - Daily
- System Analytics - Timeline

1156 intersections, November 1 – 7, 2018, All days, All times



# System Analytics – Daily (filtered)



## System Analytics



55%  
Data Connectivity  
0%  
High Latency Data  
49%  
Product Delivery  
9,142,030  
Product Delivery

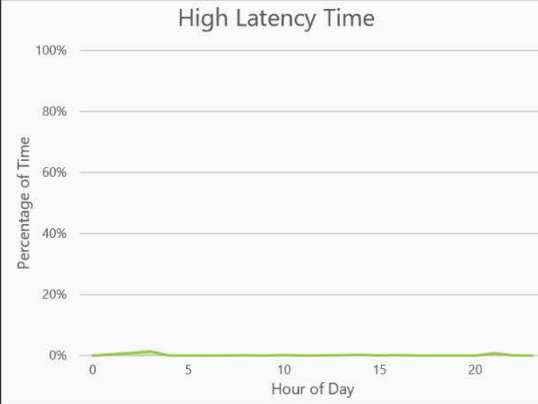

Date Range  
11/1/2018  
11/7/2018

Date  
All

Day of Week  
Multiple s...

Hour  
All

Intersection N...  
All

Operation  
All

Plan  
All

Intersection Search  
gas

Selected Int  
2514 - LAS VEGAS BLVD & CACTUS AVE  
5131 - LAS VEGAS BLVD & DALE AVE  
5167 - E Russell Rd & Las Vegas Expy  
3037 - S Las Vegas Blvd & E Bridger Ave  
3196 - 4TH ST & LAS VEGAS BLVD  
5161 - Las Vegas Fwy & W Horizon Dr

Selected Signals  
74

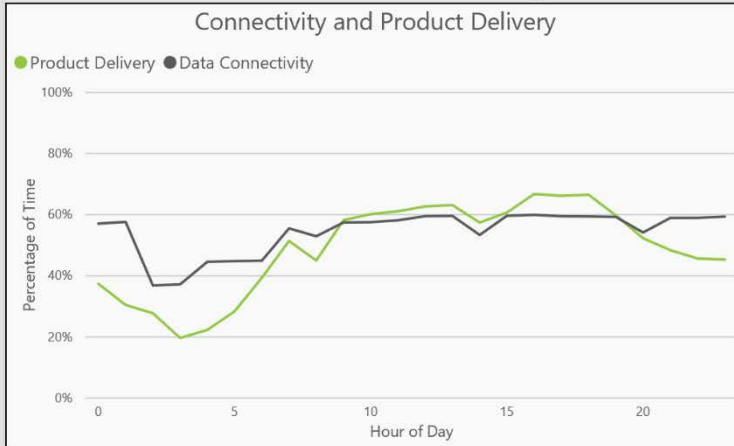

74 intersections, Tue – Thurs (within November 1 – 7, 2018), All times



# SPM Data

- System Analytics - Timeline

# System Analytics - Timeline

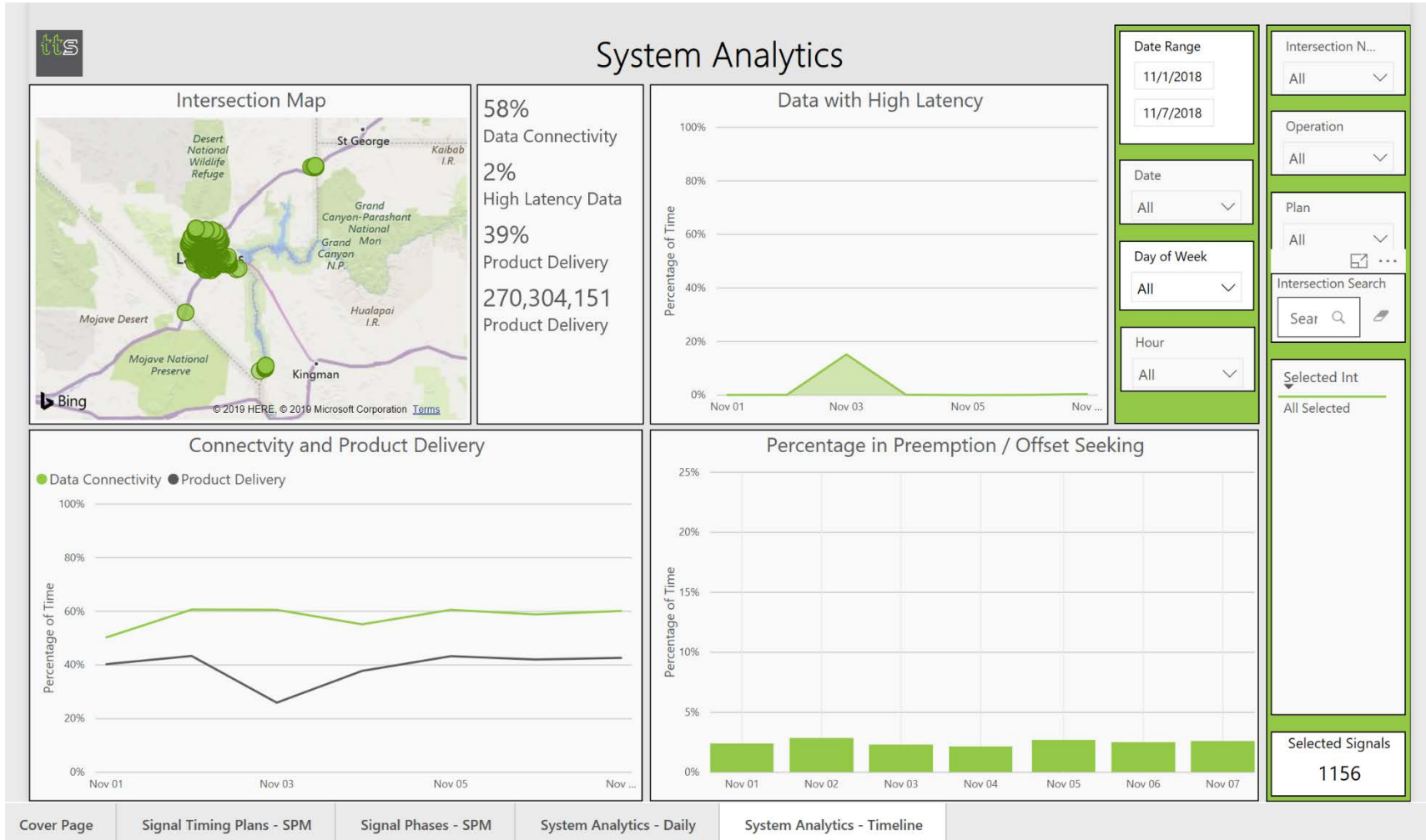

1156 intersections, November 1 – 7, 2018, All days, All times



# System Analytics – Timeline (filtered)

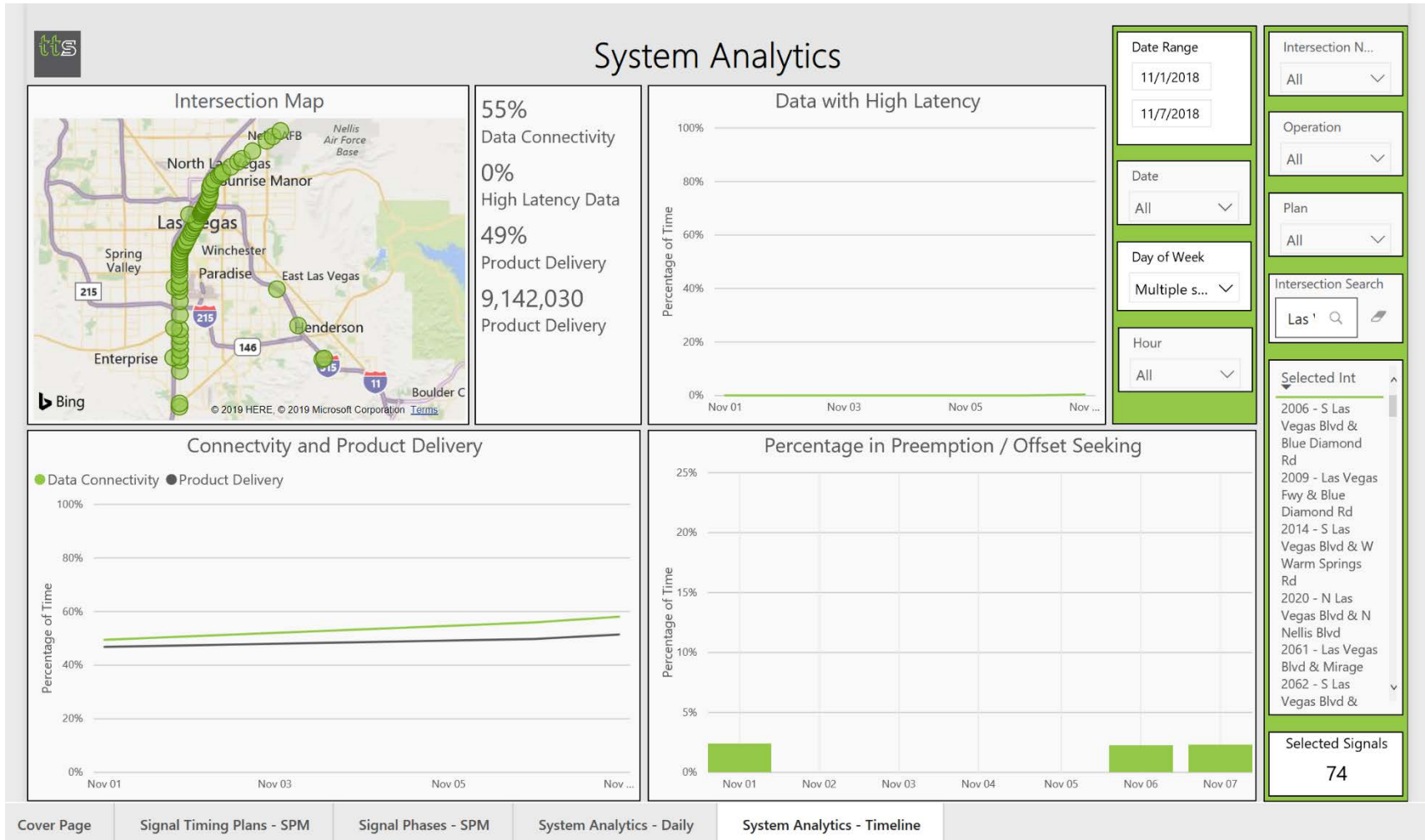

74 intersections, Tue – Thurs (within November 1 – 7, 2018), All times



# Probe Data

- Vehicle Performance Metrics (VPMs)



# Probe Data VPM Introduction

- TTS prepares dashboards of partner probe vehicle data to share back with our public agency suppliers
- Currently developing samples for City of Frisco, TX
- Probe vehicle data is projected to be ready by end of 2020
- TTS will create dashboards for all of our supplier agencies as data becomes available



# Probe Data

- KPIs
- Intersection Summaries
- Historic Summaries
  
- Hourly data
- Aggregated by day group and month



# Probe Data



## Traffic Technology Services Signal Intelligence Report

Data Sources:  
Audi of America, LLC  
Volkswagen Group of America ERL  
City of Frisco, Texas

prepared for



City of Frisco, Texas

with data between

December 2017 - May 2018

Number of Signals Included: 95

<a href="#">Cover Page</a>	<a href="#">KPIs</a>	<a href="#">Intersection Summary</a>	<a href="#">Historic Summary</a>
----------------------------	----------------------	--------------------------------------	----------------------------------

## Sample for City of Frisco, TX (95 intersections, 6 months)



# Probe Data

- KPIs





# Probe Data - KPIs



95 intersections, December '17 – May '18, All days, All times

# Probe Data – KPIs (filtered)



One intersection, May 2018, Mon-Thur, 4-6 p.m.



# Probe Data

- Intersection Summaries



# Probe Data – Intersection Summary



## Intersection Summary

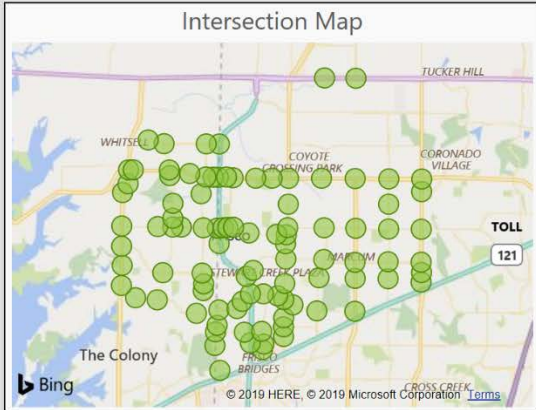

433329  
Total Arrivals

26.3  
Avg Veh Delay (s)

1612.9  
Total Veh Delay (hr)

2.5  
% Split Failures

40.7  
Avg Speed (mph)

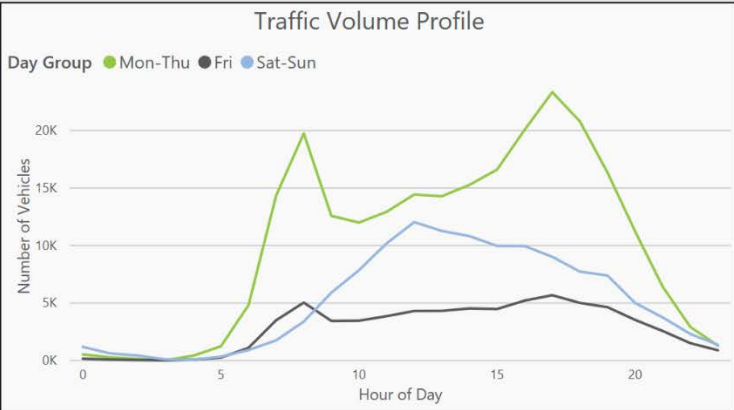

Intersection N...  
All

Date  
All

Day Group  
All

Hour  
All

Appr Dir  
All

Corridor  
All

Selected Int  
All Selected

Selected Signals  
95

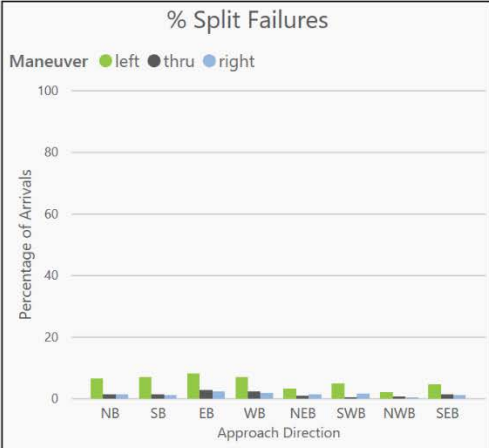
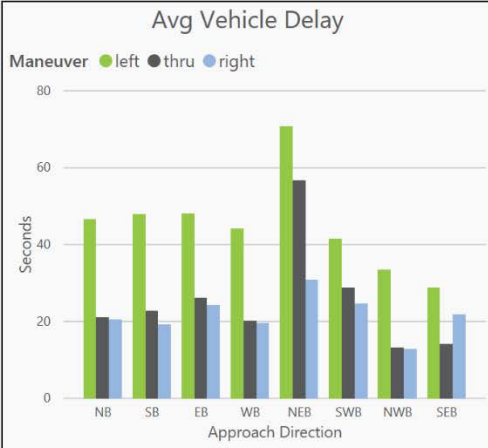
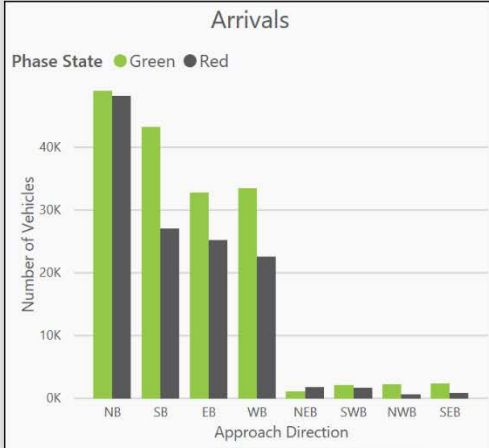

95 intersections, December '17 - May '18, All days, All times



# Probe Data – Intersection Summary (filtered)



## Intersection Summary

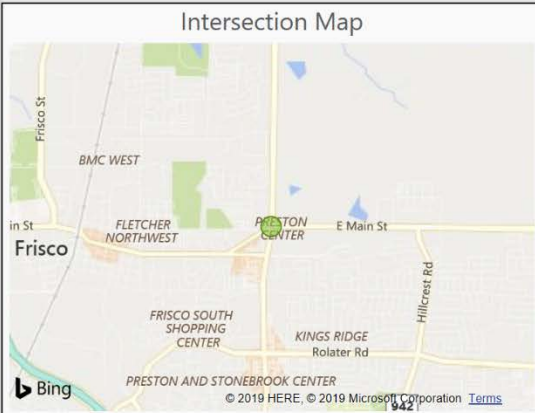

102  
Total Arrivals

88.3  
Avg Veh Delay (s)

0.9  
Total Veh Delay (hr)

3.9  
% Split Failures

36.5  
Avg Speed (mph)

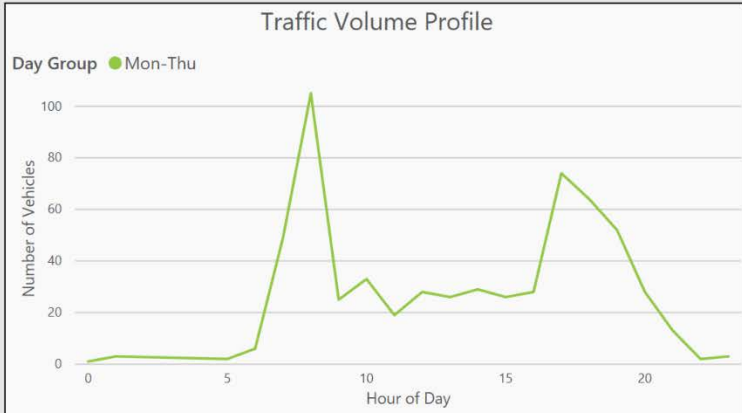

Intersection N...  
660 - PRE... ▾

Date  
May 2018 ▾

Day Group  
Mon-Thu ▾

Hour  
Multiple s... ▾

Appr Dir  
All ▾

Corridor  
All ▾

Selected Int  
660 - PRESTON RD & MAIN ST

Selected Signals  
1

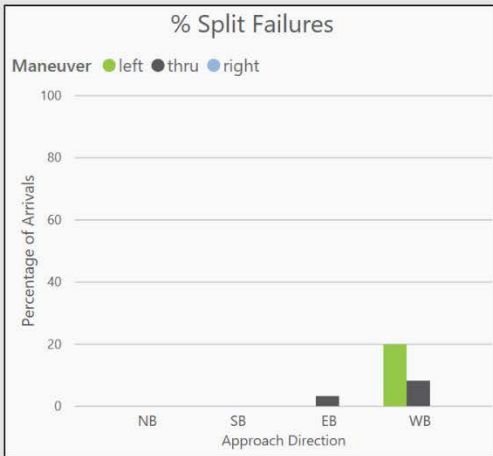
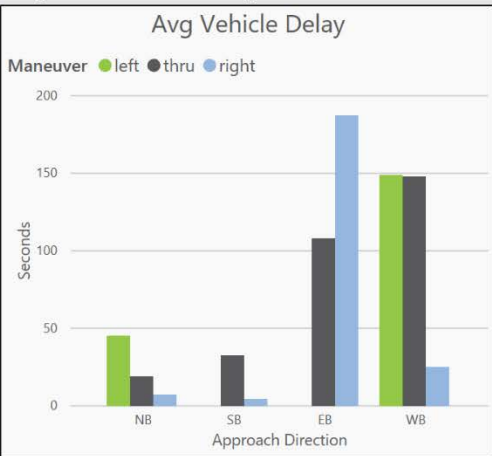
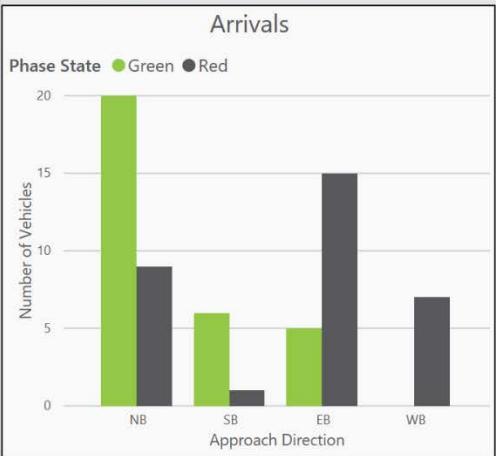

One intersection, May 2018, Mon-Thur, 4-6 p.m.



# Probe Data

- Historic Summaries





# Probe Data – Historic Summary

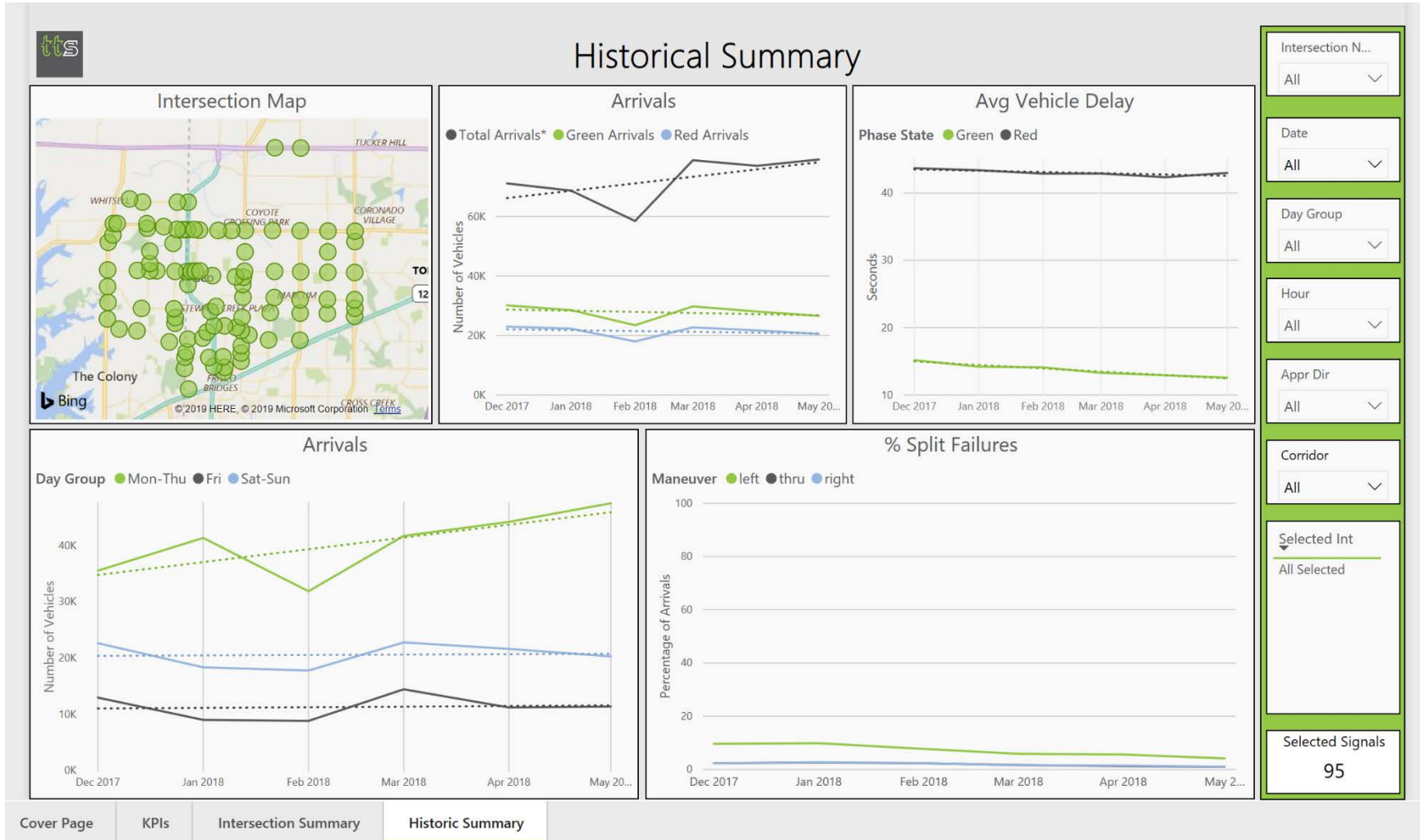

95 intersections, December '17 - May '18, All days, All times



# Probe Data – Historic Summary (filtered)

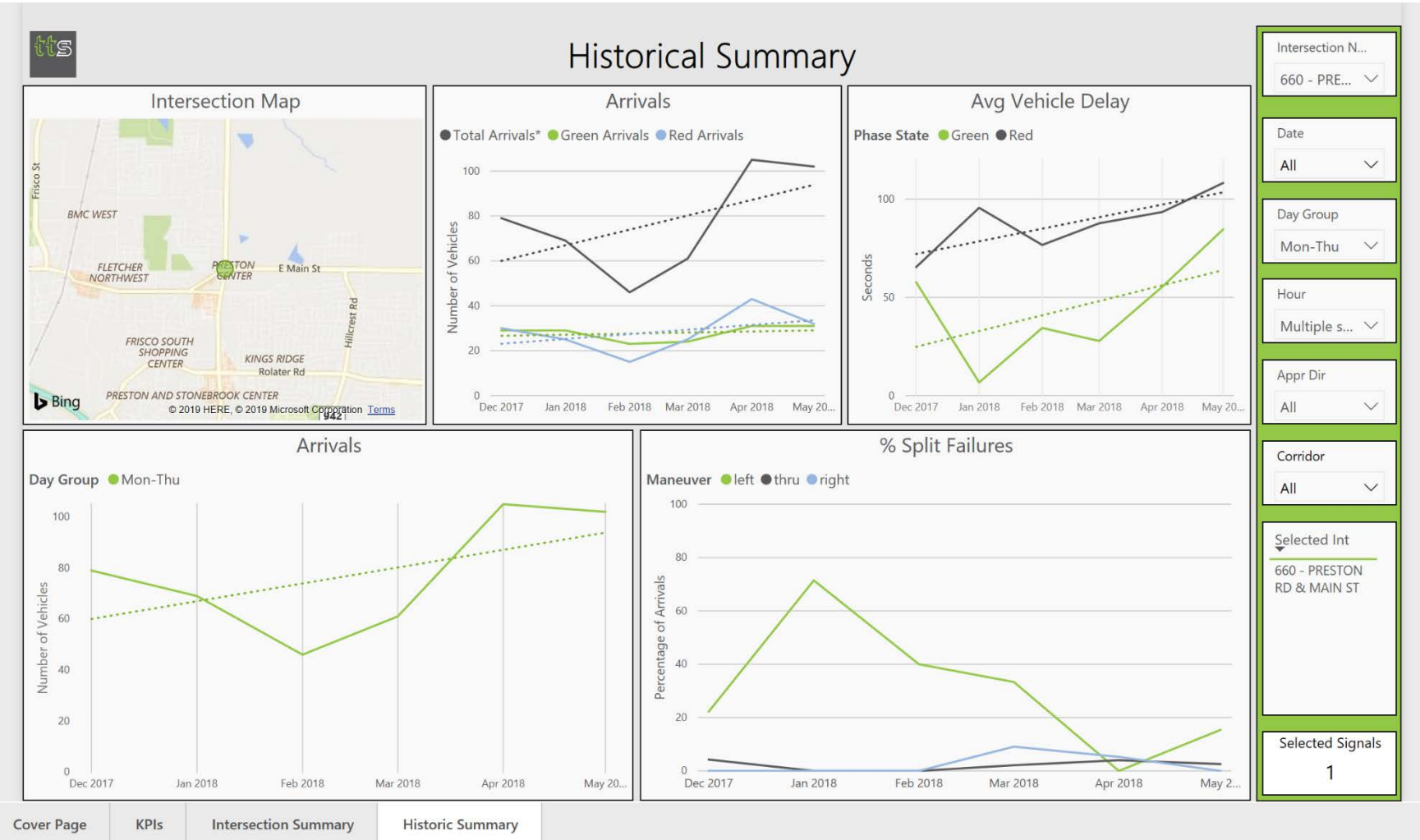

One intersection, December '17 – May '18, Mon-Thur, 4-6 p.m.

# Use Cases (Frisco, TX)

- Evaluating the signal performance operations metrics and trends over time throughout the city
- Providing feedback to the public on signal operations
  - arrivals on green %s,
  - delays,
  - split failures

# Use Cases (Frisco, TX) – cont'd

- Evaluating the effectiveness of various intersection improvements by evaluating before-and-after conditions
  - signal re-timings (including addressing residents' complaints)
  - changes to approach geometries
  - signal phasing changes



# Use Cases (Frisco, TX) – cont'd

- Examining intersection operations and planning options such as evaluating performance of protected/permissive lefts compared to protected lefts
- Exploring using this data as input when developing a corridor performance index for ongoing evaluations of operations along key corridors
- Exploring how the data can help inform reliability over time



# CONSENT AGENDA ITEM 306

CITY COMMISSION REVISED AGENDA  
AUGUST 12, 2019 | REGULAR MEETING

## TITLE

Parks and Recreation Fees

## SUMMARY

The Parks and Recreation and Finance Departments are requesting City Commission approval of Resolution 2019-20 (attached) to update fees for the Parks and Recreation Department.

Staff evaluated the fees from Resolution 2013-30 and made adjustments based upon the cost of services and current market rates. Not all fees are being revised -- the proposed revisions are summarized in the second attachment which sets forth the current and proposed rates. Winter Springs' residents will continue to receive a discounted rate for the use of City facilities, and a non-resident up-charge (65%) was applied to rentals and services.

The new fee schedule would go into effect October 1, 2019 which coincides with the anticipated start date of the new Parks and Recreation software.

## RECOMMENDATION

Staff recommends the City Commission approve Resolution 2019-20 to update fees for the Parks and Recreation Department and authorize City Manager and City Attorney to prepare all applicable documents.



**RESOLUTION NO. 2019-20**

**RESOLUTION OF THE CITY COMMISSION OF THE CITY OF WINTER SPRINGS, FLORIDA, UPDATING AND REVISING THE SCHEDULE OF FEES FOR PARKS AND RECREATION FACILITY USES AND ACTIVITIES; PROVIDING FOR REPEAL OF PRIOR INCONSISTENT RESOLUTIONS; SEVERABILITY AND AN EFFECTIVE DATE.**

**WHEREAS**, the City is granted the authority, under Section 2(b), Article VIII, of the State Constitution, to exercise any power for municipal purposes, except when expressly prohibited by law; and

**WHEREAS**, the City Commission has the authority to establish fees pursuant to section 166.201, Florida Statutes; and

**WHEREAS**, the City Commission desires to revise the fees for the City's Parks and Recreation facility uses and activities; and

**WHEREAS**, the City Commission of the City of Winter Springs finds that this Resolution is in the best interests of the public health, safety, and welfare of the citizens of Winter Springs.

**NOW, THEREFORE, BE IT RESOLVED BY THE CITY COMMISSION OF THE CITY OF WINTER SPRINGS, SEMINOLE COUNTY, FLORIDA, AS FOLLOWS:**

**Section 1.** **Recitals.** The foregoing recitals are deemed true and correct and are hereby fully incorporated herein by this reference.

**Section 2.** **Fees Established.** The City Commission hereby adopts the fee schedule set forth in Exhibit "A," attached hereto and fully incorporated herein by this reference.

**Section 3.** **Repeal of Prior Inconsistent Resolutions.** All prior inconsistent resolutions adopted by the City Commission, or parts of prior resolutions in conflict herewith, are hereby repealed to the extent of the conflict.

**Section 4.** **Severability.** If any section, subsection, sentence, clause, phrase, word, or portion of this Resolution is for any reason held invalid or unconstitutional by any court of competent jurisdiction, such portion shall be deemed a separate, distinct and independent provision and such holding shall not affect the validity of the remaining portion hereto.

**Section 5.** **Effective date.** This Resolution shall become effective on October 1, 2019.

**DONE AND ADOPTED** in regular session of the City Commission of the City of Winter Springs, Florida, this 12th day of August, 2019.

\_\_\_\_\_  
**CHARLES LACEY, Mayor**

ATTEST:

\_\_\_\_\_  
**ANDREA LORENZO-LUACES, City Clerk**

Approved as to legal form and sufficiency for  
the City of Winter Springs only:

\_\_\_\_\_  
**ANTHONY A. GARGANESE, City Attorney**



**Proposed Fee Revisions**

<u>Category</u>	<u>Resident rate</u>		<u>Non-resident rate</u>	
	<u>Current</u>	<u>Proposed</u>	<u>Current</u>	<u>Proposed</u>
<b><u>ADULT SPORTS</u></b>				
Adult Softball (per season)	\$400	\$450	\$500	\$450
<b><u>FIELD RENTALS - baseball, soccer, softball, football, lacrosse, open field (2-hr min)</u></b>				
<b><u>CWP Upper Fields</u></b>				
M-F (per hour)	\$20	\$30	\$40	\$49.50
After 5 & Weekends (per hour)	\$30	\$40	\$45	\$66
<b><u>CWP Lower Fields</u></b>				
M-F @ CWP (per hour)	\$20	\$20	\$40	\$33
After 5 & Weekends (per hour)	\$30	\$30	\$45	\$49.50
<b><u>Other fields (Trotwood, Torcaso, Sunshine, Dog Park open field)</u></b>				
M-F (per hour)	\$20	\$15	\$40	\$24.75
After 5 & Weekends (per hour)	\$30	\$20	\$45	\$33
Field Prep (per field)	\$15	\$25	\$25	\$25
Park Rangers (per hour)	\$20	\$25	\$30	\$25
5K Run Course (per race)		\$200		\$330
<b><u>Park Rental</u></b>				
Daily Pre-event set up / post-event clean up		\$150		\$247.50
Full Day Park Rental per day		\$2,000		\$3,300
Park rental security deposit		\$500		\$500
<b><u>CAMP SUNSHINE (per week)</u></b>				
Camp Sunshine (per week)	\$90	\$100	\$110	\$165
<b><u>PAVILION / GAZEBO RENTALS</u></b>				
Medium Pavilion (4-hr block)	\$40	\$40	\$60	\$66.00
Large Pavilion (4-hr block)	\$50	\$50	\$70	\$82.50
Trotwood Family Pavilion (per hr, 4-hr minimum)	\$75	\$35	\$125	\$57.75
Trotwood Family Pavilion (full day)	\$600	\$250	\$1,000	\$412.50
Trotwood Family Pavilion Security /Damage Deposit	\$200	\$200	\$200	\$200
Blumberg Gazebo (4 hr block)	\$100	\$100	\$140	\$165
<b><u>CIVIC CENTER RENTALS</u></b>				
Civic Center hrly rate weekdays before 5 per hour (no minimum)		\$35		\$57.75
Civic Center hrly rate after 5/weekends per hour (4 hour min)	\$67.75	\$50	\$74	\$82.50
Civic Center Set Up per hour (day before event only if avail.)		\$20		\$20
Civic Center Security Deposit		\$200		\$200
<b><u>SENIOR CENTER RENTAL</u></b>				
After 5 Only (per hr)		\$100		\$165
Senior Center Security Deposit		\$200		\$200



# CONSENT AGENDA ITEM 307

CITY COMMISSION REVISED AGENDA  
AUGUST 12, 2019 | REGULAR MEETING

## TITLE

Trotwood Park Fitness Zone

*Revisions are noted with \* and with text in italics*

## SUMMARY

Parks and Recreation is requesting approval to purchase above-ground outdoor fitness equipment for Trotwood Park. The outdoor fitness equipment is a simple, safe, and versatile circuit of machines that workout and stretch the entire body and is designed for ages 5 and older.

Procurement would be through the School District of Osceola County Contract ITB #SDOC-16-B-087 LH, Playground Equipment, Surfacing, Installation and Repair with Legacy Construction Services. Legacy dba Pro Playgrounds is our current contractor for the new playgrounds at Trotwood and Torcaso parks.

To save costs, the City will be re-purposing current shade structures. We are in the process of procuring the materials and installation costs for a rubberized Fitness Zone surface area in accordance with the City's purchasing policy. Accordingly, spending authorization is also requested for the surface area not to exceed \$36,000.

## RECOMMENDATION

**\* *NOTE: THIS RECOMMENDATION HAS BEEN SLIGHTLY REVISED FROM THE ORIGINAL AGENDA***

*Staff recommends the City Commission approve the purchase of fitness equipment at Trotwood Park in the amount of \$32,570 plus a 10% contingency from Pro Playgrounds from the Park Impact Fee Fund; and to approve up to \$36,000 for the Fitness Zone surface area from the Park Impact Fee Fund; and to authorize the City Manager and City Attorney to prepare and execute any and all applicable documents.*



Pro Playgrounds  
8490 Cabin Hill Road  
Tallahassee, FL 32311

**Quote**

<b>Date</b>	<b>Estimate #</b>
8/1/2019	6279

<b>Project Name</b>
Fitness Equipment



<b>Customer / Bill To</b>
City of Winter Springs 1126 East S.R. 434 Winter Springs, FL 32708

<b>Ship To</b>



**WE WILL BEAT ANY PRICE BY 5%!**

Item	Description	Qty	Cost	Total:
	Furnish outdoor fitness equipment bundle, curbing and poured in place rubber surfacing at Trotwood Park.			
	<b>**Fitness Equipment**</b>			
CPE	UP138SM - Sit-Up/Back Extension Surface Mount	1	3,670.00	3,670.00
CPE	UP357SM - Dual Chest Press with comfort Seat	1	5,290.00	5,290.00
CPE	UP180SM - Lat Pull Down	1	5,101.00	5,101.00
CPE	UP170SM - Leg Press	1	3,928.00	3,928.00
CPE	UP164SM - Cardio Walker	1	3,347.00	3,347.00
CPE	30019401XX - Parallel Bars	1	362.00	362.00
CPE	AFT14031XX - Pull-Up and Dip Station	1	1,892.00	1,892.00
CPE	60019409XX - Horizontal Ladder	1	1,833.00	1,833.00
DSC	Discount Per State Contract		-2,542.30	-2,542.30
Shipping	Combined Shipping and Freight Charges	1	1,795.00	1,795.00
LBRFT	Labor and Installation of Fitness Products - Per State Contract SDOC-16-B-087-LH 2019 Renewal	1	8,898.05	8,898.05
DSC	Additional Discount		-1,003.75	-1,003.75

**AGREED AND ACCEPTED:**  
If the above total price, scope of work, specifications, terms and conditions are acceptable, sign below indicating your acceptance and authorization for Pro Playgrounds to proceed with the work and/or sales transaction described in this quotation. Upon signature and payment in accordance with this quote, Pro Playgrounds will proceed with the work and/or sales transaction.

\_\_\_\_\_/\_\_\_\_\_/\_\_\_\_\_  
Signature Name / Title Date

<b>Subtotal:</b>	\$32,570.00
<b>Sales Tax: (7.5%)</b>	\$0.00
<b>Total:</b>	<u>\$32,570.00</u>

Terms and Conditions - Price valid for 30 days and subject to change. 1. If installation is not included with your purchase, client will be responsible for coordinating, receiving and unloading of all goods, delivery drivers will not help unload goods. 2. Client will be responsible to inspect goods for defect or damage at time of delivery and inventory parts, any deficiency or missing parts must be noted on delivery slip. 3. Client will be responsible for costs in relationship to any cancelled or missed delivery appointment. 4. Client has reviewed all items, colors and descriptions on this quote for accuracy and correctness.





# CONSENT AGENDA ITEM 308

CITY COMMISSION REVISED AGENDA  
AUGUST 12, 2019 | REGULAR MEETING

## TITLE

Acceptance of Donation for Police K9 Purchase #1

## SUMMARY

The Police Department requests the City Commission consent to accepting a donation in the amount of \$1,000 from Mr. Edward Lund to help offset the purchase of a new police K9 dog. After the return of a recently donated K9 animal named Duke to Mr. Sean Leiker, his employer Mr. Edward Lund desired to help the Police Department in securing a new animal. This donation will assist with offsetting costs incurred by the City for that purpose.

## RECOMMENDATION

Staff recommends the City Commission consent to accepting the donation from Mr. Edward Lund in the amount of \$1,000 deposited into the General Fund for the purchase of a new police K9 dog.

Chief Chris Deisler  
Winter Springs Police Department  
300 N Moss Rd.  
Winter Springs, FL 32708

Dear Chief Deisler,

My name is Edward Lund. The enclosed check is a donation of \$1,000 to the Winter Springs Police Department K9 Unit to go for the procurement of a new K9 for the city.

Sincerely,

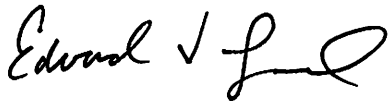
A handwritten signature in black ink that reads "Edward Lund". The signature is written in a cursive style with a checkmark-like flourish above the name.

Edward Lund



# CONSENT AGENDA ITEM 309

CITY COMMISSION REVISED AGENDA  
AUGUST 12, 2019 | REGULAR MEETING

## TITLE

Acceptance of Donation for Police K9 Purchase #2

## SUMMARY

The Police Department requests the City Commission consent to accepting a donation in the amount of \$3,000 from the Tuskawilla Homeowners Association (THOA) for the purchase of a new police K9 dog. This donation was approved by the THOA Board during their last meeting and will assist with offsetting costs incurred by the City for that purpose.

## RECOMMENDATION

Staff recommends the City Commission consent to accepting the donation from the Tuskawilla Homeowners Association in the amount of \$3,000 deposited into the General Fund for the purchase of a new police K9 dog.



# **CITY COMMISSION**

## REGULAR MEETING MINUTES

**MONDAY, JULY 8, 2019 AT 6:30 PM**

CITY HALL - COMMISSION CHAMBERS  
1126 EAST STATE ROAD 434, WINTER SPRINGS, FLORIDA

## CALL TO ORDER

The Regular Meeting of Monday, July 8, 2019 of the City Commission was called to Order by Mayor Charles Lacey at 6:31 p.m. in the Commission Chambers of the Municipal Building (City Hall, 1126 East State Road 434, Winter Springs, Florida 32708).

### Roll Call:

Mayor Charles Lacey, present  
Deputy Mayor Kevin Cannon, present via telephone  
Commissioner Jean Hovey, present  
Commissioner Ted Johnson, present  
Commissioner TiAnna Hale, present  
Commissioner Geoff Kendrick, present  
Interim City Manager Shawn Boyle, present  
City Attorney Anthony A. Garganese, absent  
Senior City Attorney Kristin Eick, present  
City Clerk Andrea Lorenzo-Luaces, present

A moment of silence was held. The Pledge of Allegiance followed.

Mayor Lacey said, "I would ask if there is any objection to adopting the Agenda with the addition of an item, essentially after '101', we will call it '102' for a presentation on Water Quality." No objections to this were voiced.

Further regarding the Agenda, Commissioner TiAnna Hale mentioned perhaps pulling Consent Agenda Item "301", and Deputy Mayor Kevin Cannon spoke of pulling Consent Agenda Item "302", and he had a question on Consent Agenda Item "303."

Mayor Lacey noted that the Consent Agenda Items could be addressed when we get to the Consent Agenda and added, "With that, the Agenda stands Adopted, because I am hearing no other objection with what we're calling '102', a presentation on Water Quality of the City of Winter Springs."

## **AWARDS AND PRESENTATIONS**

### **100. Recognizing Winter Springs Babe Ruth Baseball and Softball All-Stars Teams**

---

Mr. Chris Caldwell, Director, Parks and Recreation Department recognized the Winter Springs Babe Ruth organization, the 10 and under “Quicksilver” Florida Babe Ruth Champions in the open division; and the 8 and under “Bulldogs” who were State Champions.

### **101. Presentation of Lifesaving Awards to Officers Jesus Hilerio, Andrew Jones, and Ben Rivera**

---

Chief of Police Chris Deisler spoke of the incredible lifesaving efforts of Officer Jesus Hilerio, Officer Andrew Jones, and Officer Ben Rivera and then presented each with an Award for their efforts.

In other City business, Mayor Lacey presented a Certificate to Commissioner Hale for her participation in the Advanced Institute for Elected Municipal Officials (IEMO) program held via the Florida League of Cities.

## **ADD-ON**

### **102. Water Quality**

---

Interim City Manager Shawn Boyle opened this discussion on Water Quality.

Ms. Lena Rivera, P.E., D.WRE, Director, Public Works and Utilities Departments introduced herself and gave a brief overview of her credentials and work experience.

*Mr. Robbie Gonzalez, P.E., Senior Project Manager, CPH, 1117 East Robinson Street, Orlando, Florida:* introduced himself and spoke of his qualifications and background.

*Mr. David Mahler, P.E., Senior Vice President/Associate, CPH, 1117 East Robinson Street, Orlando, Florida:* also introduced himself and gave an overview of his background and qualifications.



Mr. Gonzalez then referred to a PowerPoint presentation and spoke on aspects related to the City's water system, sampling, the Department of Environmental Protection, testing, compliance, and timelines.

Commissioner Geoff Kendrick asked if they could get a copy of the presentation? Mr. Gonzalez stated, "Yes, Sir."

Deputy Mayor Cannon said, "I would like to ask that the presentation that was just used by the Engineers, be incorporated into the official record of the City as an attachment; and also that we place it on the website of the City together with our Report to better explain to our residents." Commissioner Kendrick noted, "Agreed." Commissioner Hale stated, "Absolutely." Commissioner Ted Johnson added, "That is a good idea."

Mayor Lacey then asked Interim Manager Boyle, "Do you have any technical problem with putting the Report on the webpage?" Interim Manager Boyle responded, "No, Sir." Mayor Lacey summarized, "Consider it done."

Continuing, Interim Manager Boyle stated that, "Our water is safe – is very safe actually." Furthermore, Interim Manager Boyle then commented that City employees care greatly about the job they do, and added regarding Water Quality, "We'll close the faucets off before we'll produce a product that will harm anyone."

Interim Manager Boyle said for the Record that Staff had contacted the Department of Environmental Protection (DEP) regarding these matters, that DEP told the City that there was nothing wrong with the water, how similar issues were happening all over the State, and that DEP actually made a mistake on page 5 of the "Annual Drinking Water Quality Report" for Winter Springs.

Continuing, Interim Manager Boyle pointed out, "We have now been ordered to re-issue this report. As you know, we are required to follow the instructions of the State; we are a political subdivision of the State, so we will be reissuing this Report." Interim Manager Boyle added, "Mayor, we will be reissuing this Report with the corrections on it."

Further remarks followed from Interim Manager Boyle and Commissioner Kendrick.

Interim Manager Boyle pointed out, "I think the information we're about to present in the Budget, will not only set the tone for where the City is going in the future. There is an unprecedented amount of spending that we will be presenting to continue the quest for perfect water."

Commissioner Hale commented on how Staff has been a great help in past situations and should anyone have an issue, to please reach out.

Commissioner Johnson noted, "With the website, I assume we are going to go ahead and post the revised version of our Report for the website along with a notice that it's been updated, because citizens need to know about that."

Furthermore, Commissioner Johnson then shared his thanks with Ms. Rivera, CPH and staff for their assistance.

Interim Manager Boyle noted, "We're required by the state - they directed us to re-publish the report and send it out and we will do that ASAP."

Comments followed on how previous information was disseminated to residents and how Staff hoped to proceed.

Further remarks continued that Staff and the experts with CPH said they have no issues drinking our water, that the collective experience of those who spoke this evening totaled more than 100 years of experience. Deputy Mayor Cannon mentioned that some people would like changes to the taste and/or odor of the City's water and asked Interim Manager Boyle if this could this be explored at a future project or Budget. Interim Manager Boyle stated, "Yes."

Deputy Mayor Cannon thanked Ms. Rivera, the Engineers, as well as and Staff for their assistance. Mayor Lacey also offered his thanks.

## **INFORMATIONAL AGENDA**

### **200. Current Development Projects Update**

---

This Agenda Item was not discussed.

## **PUBLIC INPUT**

*Mayor Lacey opened "Public Input".*

*Mr. Andrew Zacharias, 222 Oak Road, Winter Springs, Florida:* commented on a recent parking project that involved the clearcutting of trees, thought there was already adequate parking, although one may need to walk some, that the property owner needed to manage the parking load, suggested that signage could be used to point to where additional parking spaces were, and hoped money and trees could be saved.

*Ms. Laura Tweed, Post Office Box 702242, St. Cloud, Florida:* said she was a former resident, was a health, human rights and veteran advocate as well as an insurance agent, had started a website related to local cancer deaths, and attended this meeting to educate people regarding cancer, issues with water tests, a sink hole issue in Mulberry, Florida and asked several questions about tests, timing, location, and data.

*Mr. Arsenio Calle, 110 Arrowhead Court, Winter Springs, Florida:* referenced the current good economy and inquired if the money coming into the City as a result of the good economy would be kept in reserve funds; and asked if the City still provided funds to what has been known as the UCF (University of Central Florida) Incubator.

*Mayor Lacey closed "Public Input".*

## **CONSENT AGENDA**

### **300. Surplus Assets**

---

No discussion.

### **301. Amendment for Emergency Generator at Police Department**

---

Commissioner Hale suggested the wording should read, "Authorize the City Manager and City Attorney to modify and execute a Contract for completion of the installation of the generator." Mayor Lacey said to Commissioner Hale, "Would it satisfy your concern if when the Motion is made to approve the Consent Agenda, it incorporates that language?" Commissioner Hale stated, "Absolutely."

### **302. Resolution 2019-18 - Agreement with Traffic Technology Services, Inc. to Access Traffic Signal Data**

---

Deputy Mayor Cannon spoke of his concern with the Disclosure Agreement.

Mr. Bryant Smith, III, P.E., CFM, City Engineer noted, "The City owns all of our traffic signals and we work through Seminole County to maintain that infrastructure as well as the timing for it."

Continuing, Mr. Smith explained that this allows the contractor "To install their technology on the signals and collect additional data while they're also being used in smart vehicles and autonomous vehicles in the future and collect that data as well. So part of this agreement is basically to indemnify us from any wrongdoing if something happened with the data."

Deputy Mayor Cannon said, "I would like our City to be able to have the benefit of that real time traffic data that is captured, as we have the massive influx of traffic coming from west to east through our City or vice versa, east to west. In other words, will TTS provide us with that same real-time data so that Bryant, you and our department could take that into consideration as we as a City look at traffic management, cut-through traffic along say Winter Springs Boulevard and the like.

I don't see that language in this Disclosure Agreement, and I would like to have that in the Disclosure Agreement and would like the opportunity for Anthony (Garganese, City Attorney) to discuss this with us further. So, my request genuinely and for the Commission is that we postpone item '302' until the next Commission Meeting when Anthony is present; so that we can get into that in a little bit more detail."

Deputy Mayor Cannon commented, "Yes, I would request then Mayor, to pull item '302' from the Consent Agenda for separate consideration."

Mayor Lacey stated, "We will take that out and address it separately."

### **303. Acceptance of Recreational Trails Program Grant**

Referencing Central Winds Park, Deputy Mayor Cannon asked where the trailhead rest rooms would be placed, to which Mr. Caldwell explained, "The proposed plan is just east of the Dog Park in that area by the baseball fields and that parking lot right there - that's the proposed area right now."

*Commissioner Hale left the dais at approximately 7:43 p.m.*

### **304. Recreation Program Partnership Agreement – Winter Springs Babe Ruth**

This Agenda Item was not discussed.

### **305. Recreation Program Partnership Agreement – Winter Springs Grizzlies**

No discussion.

### **306. Recreation Program Partnership Agreement – Winter Springs Basketball League**

There was no discussion on this Agenda Item.

### **307. Donation Acceptance for Moss Park Basketball Court**

No discussion.

**308. Designation of Voting Delegate for the August 2019 Florida League of Cities Annual Conference**

This Agenda Item was not discussed.

**309. Minutes from the Monday, May 20, 2019 City Commission Special Meeting**

No discussion.

**310. Minutes from the Monday, June 10, 2019 City Commission Regular Meeting**

There was no discussion on this Agenda Item.

Mayor Lacey then said, "I am looking for a Motion to approve the Consent Agenda without item '302' and with '301' modified to authorize the City Manager to execute the contracts."

**"SO MOVED." MOTION BY COMMISSIONER HOVEY. SECONDED BY COMMISSIONER JOHNSON. DISCUSSION.**

**VOTE:**

**COMMISSIONER JOHNSON: AYE  
DEPUTY MAYOR CANNON: AYE  
COMMISSIONER HOVEY: AYE  
COMMISSIONER KENDRICK: AYE**

*Commissioner Hale returned to the dais at approximately 7:45 p.m.*

**COMMISSIONER HALE: AYE  
MOTION CARRIED.**

❖❖ AGENDA NOTE: CONSENT AGENDA ITEM “302” WAS FURTHER DISCUSSED, AS DOCUMENTED NEXT. ❖❖

## **CONSENT AGENDA**

### **302. Resolution 2019-18 - Agreement with Traffic Technology Services, Inc. to Access Traffic Signal Data**

---

**RELATED TO CONSENT AGENDA ITEM “302”, “I WOULD LIKE TO MAKE A MOTION THAT WE POSTPONE A DECISION ON ITEM ‘302’ UNTIL THE NEXT COMMISSION MEETING; SO THAT WE WOULD HAVE AN OPPORTUNITY TO REVIEW WITH OUR CITY ATTORNEY – THE DISCLOSURE AGREEMENT AND SOME OF THE LANGUAGE CONTAINED THEREIN.” MOTION BY DEPUTY MAYOR CANNON.**

**MAYOR LACEY SUMMARIZED, “A MOTION TO POSTPONE ‘302’ TO THE TIME CERTAIN OF AUGUST 12.”**

**DEPUTY MAYOR CANNON THEN ADDED, “AS LONG AS ANTHONY (GARGANESE) WAS DUE TO BE BACK IN TOWN AT THE AUGUST 12<sup>TH</sup> COMMISSION MEETING, THAT WOULD BE MY MOTION.” MAYOR LACEY ADDED, “YES, HE IS EXPECTED BACK.”**

**SECONDED BY COMMISSIONER JOHNSON. DISCUSSION.**

**COMMISSIONER KENDRICK INQUIRED IF THIS DELAY WOULD CAUSE ANY ISSUES. MR. SMITH RESPONDED, “NO.”**

**WITH FURTHER REMARKS, MR. SMITH POINTED OUT, “THE REAL TIME DATA IS SHARED WITH THE COUNTY THROUGH THEIR SYSTEM AND WE HAVE ACCESS TO THE COUNTY SYSTEM SO WE DO HAVE REAL TIME DATA.”**

**COMMISSIONER JOHNSON INQUIRED, “SO, WE WILL RECEIVE THAT INFORMATION?”**

**MR. SMITH RESPONDED, “YES. WE’LL JUST BE ABLE TO LOG INTO THEIR SYSTEM. WE ALREADY HAVE ACCESS TO MOST OF THE COUNTY’S REAL TIME TRAFFIC DATA.”**



**SENIOR ATTORNEY KRISTIN EICK STATED, “THE RESOLUTION DOES PROVIDE IN THE RECITALS THAT THE REAL TIME TRAFFIC SIGNAL DATA WILL BE PROVIDED AND IT DOES DESCRIBE SOME OF THE REPORTS AND INVENTORIES THAT WILL BE PROVIDED, BUT I’M HAPPY TO FURTHER DETAIL THAT IF THAT’S THE WISH OF THE COMMISSION.”**

**VOTE:**

**COMMISSIONER HOVEY: AYE  
COMMISSIONER HALE: AYE  
COMMISSIONER KENDRICK: AYE  
DEPUTY MAYOR CANNON: AYE  
COMMISSIONER JOHNSON: AYE  
MOTION CARRIED.**

Mayor Lacey said to Interim Manager Boyle, the action is on you to bring it back in four (4) or five (5) weeks, in August.”

## **PUBLIC HEARINGS AGENDA**

**400. Not Used**

---

## **REGULAR AGENDA**

**500. FY 2020 Budget Overview, Millage Cap, Loan Forgiveness**

---

This presentation began with comments from Interim Manager Boyle on the economy, job growth, yield curves, health insurance, and Pension funds.

Interim Manager Boyle then pointed out, “One of the chief reoccurring issues that came up in a lot of the Visioning meetings were the sidewalks and the infrastructure. This Budget has unprecedented increases in spending for infrastructure and sidewalks.”

Further, Interim Manager Boyle added, “We’re proposing – assuming you accept this, that we’re going to do over a million dollars of paving which is a substantial amount; and that we’ve got a couple of hundred thousand dollars in here for sidewalk replacement. That doesn’t include the sidewalk replacements that we’re going to be doing ourselves.”

In terms of the well-regarded parks in Winter Springs, Interim Manager Boyle noted, “This Budget again, has unprecedented levels of spending for parks. For capital alone, we have in excess of five million dollars (\$5,000,000.00) for improvements for Parks in 2020. There are two (2) particular items that will be before you, that will come back to you shortly on and we’re looking for guidance on.” Interim Manager Boyle explained that he was referring to the Fieldhouse project at Torcaso Park and also the Amphitheatre.

Interim Manager Boyle noted, “This Budget does not address an issue that is on the horizon which is the replacement of our Wastewater Plants but it does set the stage again for us to go out and review engineering plans and begin to take a step in that direction.” Interim Manager Boyle explained that the City’s two (2) Wastewater Plants are basically near end of life status, and along with a feasibility study that had been done a few years ago, Staff would like to bring a plan forward to commence a discussion on what would result in a plan to replace the two (2) Wastewater Plants.

Continuing, Interim Manager Boyle added, “We have dollars in here for Consultants to start that discussion – the plan for whoever is sitting in this seat, and hopefully me in some capacity will be to bring that forward in probably December or first quarter of 2020, to start that ball rolling.”

Further comments followed on possibly looking into improving the smell and taste of water to which Interim Manager Boyle pointed out that there were funds in the Budget to look into this.

Regarding landscaping and the overall aesthetics of the City, Interim Manager Boyle commented that, “We want canopy and we want to improve the visuals along the Cross Seminole Trail; and so this plan - I’ve got people working on it right now, to request from the County, permission to plant in the right-of-way on the Trail.

So, there are considerable dollars in here to address the aesthetic along the Trail; there’s also considerable dollars in here to address things like the curbs and gutters and sidewalks from an aesthetic appearance.”

Interim Manager Boyle spoke of current efforts to cleaning concrete and landscaping that Staff was currently working on and the Budget included funds to continue that.

Next, Interim Manager Boyle spoke of the Solid Waste Contract, extension(s) and said that most likely later in the year, “We’re going to come before you and discuss that and see what we can do and what direction we want to go in.”

Related to Assessment Districts, Interim Manager Boyle mentioned they had received some complaints regarding Hawk’s Reserve, in terms of the level of service. Interim Manager Boyle pointed out, “Right now, they’re assessed at seventy-five dollars (\$75.00), and we want to take it to eighty-seven [dollars] (\$87.00).”

Further remarks.

Commissioner Jean Hovey asked Interim Manager Boyle, “On the Master Plan for the Wastewater and the drinking water, have we looked at going out for Grants from either the state or federal government to help us fund some of that?”

Interim Manager Boyle responded, “All of the engineering firms are absolutely on board with going out and seeking State and Federal funding. I personally have a meeting with our State Representative who also was offering assistance in that matter.”

Commissioner Hovey then referenced the Parks Master Plan and suggested that before moving forward with the Fieldhouse or Amphitheater, that the Master Plans, including Torcaso Park, be reviewed before any decisions were made.

Interim Manager Boyle stated, “Yes.”

Mayor Lacey then suggested that perhaps we hold a Workshop on the Parks Master Plan with Mr. Caldwell to see what fits best for the City going forward.

**“I WOULD LIKE TO MAKE A MOTION TO EXTEND TIME THROUGH THE SECOND ROUND OF PUBLIC INPUT.” MOTION BY COMMISSIONER HOVEY. SECONDED BY COMMISSIONER JOHNSON. DISCUSSION**

**MOTION CARRIED UNANIMOUSLY.**

Further comments followed that various members of our City Commission had met or would be meeting with State Representative David Smith regarding possible assistance he might be able to offer Winter Springs, and to help ease the tax burden on City residents.

Commissioner Kendrick complimented Interim Manager Boyle and Chief of Police Chris Deisler on their recent management efforts.

Remarks followed regarding what waste services cost in another State in comparison to what Winter Springs' residents pay and the conundrum the City faces regarding possibly rebidding our refuse services or using contract extensions.

Deputy Mayor Cannon also complimented Interim Manager Boyle on his presentation, commended Staff, and commented on his personal concerns with health care costs and the Pension. Further, in terms of the Pension, Deputy Mayor Cannon asked Interim Manager Boyle when he thought a further downward adjustment might be enacted. Discussion.

Continuing, Deputy Mayor Cannon added that he agreed with Commissioner Hovey's suggestion regarding looking at the Parks Master Plan; with consideration of plans to increase tree canopy and the Cross Seminole Trail.

Deputy Mayor Cannon then said that from talking with State Representative David Smith, "We are under a firm deadline of September Shawn (Boyle), to get any proposed plans to David Smith, if he is going to put it in a spending bill for the next legislative session - they meet early next year.

So, the deadline that the Speaker of the House has imposed is sometime in September - I would just encourage you and Lena (Rivera) and our Public Works folks to get moving on that, sooner rather than later." Remarks followed on whether we would need to present and ratify a Resolution, and if that was the case, then it would need to be placed on the August Agenda." Interim Manager Boyle stated, "Yes, Sir."

**"I MAKE THE MOTION THAT THE CITY OF WINTER SPRINGS ADOPT RESOLUTION 2019-19 TO FORGIVE THE INTERNAL LOAN TO THE CENTRAL WINDS GENERAL OBLIGATION DEBT SERVICE FUND FROM CAPITAL PROJECT FUND '#305' AND DISCONTINUE THE VOTED DEBT MILLAGE RATE." MOTION BY COMMISSIONER HOVEY. SECONDED BY COMMISSIONER KENDRICK. DISCUSSION.**

**VOTE:**

**DEPUTY MAYOR CANNON: AYE**  
**COMMISSIONER HOVEY: AYE**  
**COMMISSIONER JOHNSON: AYE**  
**COMMISSIONER HALE: AYE**  
**COMMISSIONER KENDRICK: AYE**  
**MOTION CARRIED.**

**"I WILL MAKE THE MOTION THAT THE CITY OF WINTER SPRINGS ADOPT RESOLUTION 2019-12 TO ESTABLISH THE PROPOSED OPERATING MILLAGE RATE AT 2.4300 MILLS AND PUBLICLY ANNOUNCE THAT THE PROPOSED OPERATING MILLAGE RATE IS 6.72% MORE THAN THE COMPUTED ROLLED-BACK RATE OF 2.2770 MILLS; AND ESTABLISH THE PUBLIC HEARING REGARDING THE PROPOSED MILLAGE RATE AND TENTATIVE BUDGET AS SEPTEMBER 9, 2019 AT 6:30 PM AT 1126 EAST STATE ROAD 434 IN WINTER SPRINGS, FLORIDA." MOTION BY COMMISSIONER HOVEY. SECONDED BY COMMISSIONER HALE. DISCUSSION.**

**VOTE:**

**COMMISSIONER KENDRICK: AYE**  
**COMMISSIONER JOHNSON: AYE**  
**COMMISSIONER HALE: AYE**  
**COMMISSIONER HOVEY: AYE**  
**DEPUTY MAYOR CANNON: AYE**  
**MOTION CARRIED.**

Brief comments.

**501. SR 434 Buffer Requirements per Chapter 20 - Zoning Discussion**

Mr. Christopher Schmidt, Director, Community Development Department began this Agenda Item discussion by showing some photographs of different easements, setbacks, and landscape buffers from various properties around the City.

Next, Mr. Smith spoke of right-of-ways, sidewalk requirements, and greenspace buffers.

Further comments continued.

Deputy Mayor Cannon stated, "I would be more inclined to go with setbacks more consistent with what we have at Jesup's Reserve, what we have at West End Professional Center, what we have over at the Town Center." Deputy Mayor Cannon then mentioned his concern that ten feet (10') would not be wide enough for trees that could provide a nice canopy, so greenspaces should be more like fifteen to seventeen feet (15' – 17') wide.

Deputy Mayor Cannon also suggested the City's Overlay District be considered, as well as the vertical height of buildings. Continuing, Deputy Mayor Cannon pointed out that Attorney Garganese had noted that, "In many jurisdictions, the higher you go with the number of stories, they do a step effect like a terracing effect and other techniques like that Chris (Schmidt), that tend to reduce that illusion."

Commissioner Kendrick agreed with what Deputy Mayor Cannon had said, noted that he was not in favor of zero setbacks, and that Jesup's Reserve had a more preferred look.

Referencing the upcoming Community Visioning Session to be held on Thursday, July 11, 2019, Commissioner Johnson said he was sure that a lot of attendees would be commenting on this same matter, and he thought it would help the general public if these photographs of different setbacks just presented, could be shown. Mr. Schmidt stated, "We can do that."

Next, Deputy Mayor Cannon mentioned a recent City Commission Workshop when a resident, Mr. Kevin McCann had shown some photographs of buffers along Lake Mary Boulevard. Deputy Mayor Cannon thought it would be helpful if City Staff could take some measurements of the buffers in Lake Mary before the July 11, 2019 Community Visioning Session, and share this information with the attendees.

Commissioner Kendrick spoke of his frustration with a recent decision involving MetroPlan Orlando and a lower priority ranking for the expansion of State Road 434 going eastward. Commissioner Kendrick hoped the Commission would agree to having Staff look into this issue, and then along with what Commissioner Kendrick might find out through other area Elected Officials, this could be discussed at the next City Commission meeting.

Mr. Smith explained to the Mayor and City Commission that he serves on a couple of Committees with MetroPlan Orlando and pointed out, "The past year or so, federally and state wide, there is a new initiative - so it changed a lot of the performance measures from your level of service, which is your traffic counts on roadways, to taking into account, pedestrian fatalities, traffic fatalities and things of that nature.

So, with those performance measures along with environmental concerns in some areas, it changed the way the projects were ranked. So, this project I believe was around twenty (20), before the project initially got dropped in the fifties (50's) or sixties (60's), then it was split into two (2) phases; and the phase that you're speaking about, probably the more important phase of the two (2) coming from [State Road] 417 over to I believe Smith Street near where the old Town House restaurant is, that got moved up to about forty-one (41). So, the initial study that was done is kind of a kick off study to do another study, as bad as that sounds. That's how those processes work. The County is funding that.

At this point, the project study team is going back and looking at some intermediate fixes to help with traffic, and then the County who's kind of heading this off with Oviedo and Winter Springs as well, is looking at possibly, if we help fund the design, if that can move it up in the rankings; because then there would be less money devoted to some of those other projects that it could pull from."

Mr. Smith continued, "The next phase would be what's called PD&E, so it's Project Development and Engineering - so that's where it would kind of get knocked down to one (1) or two (2) ideas for what the project could be, and then the true cost estimates could come out."

Remarks continued regarding traffic issues.

Commissioner Kendrick said he would still check into what he could do, and Deputy Mayor Cannon suggested we needed to become more vocal with fellow Elected Officials and the County, especially in terms of funding.

Mayor Lacey said to Mr. Schmidt and Mr. Smith, "On the question of the 434 buffer requirements, do you feel like you have what you need or do you have any specific questions for the Commission?" Mr. Schmidt responded, "Yes, we feel comfortable."



## **502. City Commission Appointment/Reappointment Opportunities**

**REGARDING THE SEAT ONE POSITION ON THE OAK FOREST WALL AND BEAUTIFICATION DISTRICT ADVISORY COMMITTEE, MOTION TO REAPPOINT WILLIAM HOGABOOM. MOTION BY COMMISSIONER HOVEY. SECONDED BY COMMISSIONER JOHNSON. DISCUSSION.**

**VOTE:**

**COMMISSIONER HALE: AYE  
COMMISSIONER KENDRICK: AYE  
DEPUTY MAYOR CANNON: AYE  
COMMISSIONER JOHNSON: AYE  
COMMISSIONER HOVEY: AYE  
MOTION CARRIED.**

**MOTION TO APPOINT ASHLEY BULEY FOR THE SEAT FOUR POSITION ON THE OAK FOREST WALL AND BEAUTIFICATION DISTRICT ADVISORY COMMITTEE. MOTION BY COMMISSIONER HALE. SECONDED BY COMMISSIONER JOHNSON. DISCUSSION.**

**VOTE:**

**COMMISSIONER HOVEY: AYE  
COMMISSIONER JOHNSON: AYE  
COMMISSIONER HALE: AYE  
COMMISSIONER KENDRICK: AYE  
DEPUTY MAYOR CANNON: AYE  
MOTION CARRIED.**

## **REPORTS**

### **600. City Attorney Anthony A. Garganese, Esquire**

Senior City Attorney Eick had no Report.

## **601. Interim City Manager Shawn Boyle**

---

No Report was given.

## **602. City Clerk Andrea Lorenzo-Luaces, MMC**

---

City Clerk Andrea Lorenzo-Luaces noted that the Seminole County Supervisor of Elections advised us that he would like to hold a community meeting here at City Hall.

With brief remarks, Mayor Lacey stated, "I would suggest to the Commission as long as he is fulfilling his duty as a Charter Officer and doesn't cross the line, that as much as we have made the Chambers available to other Elected Officials, we should extend the same courtesy; but, I would do so with the warning to him that that is the expectation."

Further comments.

Mayor Lacey then said to the City Commission, "Any objection to giving that direction to Andrea (Lorenzo-Luaces)?" Commissioner Kendrick stated, "No." Deputy Mayor Cannon remarked, "No". No objections were voiced.

Continuing, Deputy Mayor Cannon mentioned, "I think that it would be good for us as the City, to invite our Supervisor of Elections to give an update about Elections, Election security, and all of these matters that are certainly foremost in many people's minds, and I think we ought to host it and invite him to come and be our guest speaker." Mayor Lacey stated, "Sounds good to me."

Discussion ensued.

Mayor Lacey then commented to City Clerk Lorenzo-Luaces, "Per the Deputy Mayor's suggestion, when you extend the response to his request, would you also invite him to come to a Commission meeting..." City Clerk Lorenzo-Luaces stated, "...Absolutely..." Mayor Lacey continued, "...And brief us." City Clerk Lorenzo-Luaces added, "Yes, Sir."

Deputy Mayor Cannon added, "I didn't think we should invite him to a Commission meeting, I think - we should extend the invite to him to conduct a workshop for educational purposes in the City to help advise all of our residents about changes in Elections, Laws, and all these different things that are clearly within his bailiwick.

I think it is good for us as a Commission, periodically, to hold that type of an invited public forum. I don't want to say Commission meeting in those formalities or Commission Workshop in those formalities, but I think it is good for us to host our Constitutional Officers or representatives from the County Commission – our Clerk of the Court, things like that. I think it is good for the residents and I think it is good for our City; so, that's kind of what I envisioned, is that we extend an invite to the different Constitutional Officers of the County."

With further comments on an event that the Seminole County Supervisor of Elections might host, and a Town Hall type event that we would hold with other Elected Officials, Deputy Mayor Cannon further suggested, "I think it would be good for us as a Commission, periodically, to post and invite one of our County Constitutional Officers to come in to our City Chambers for the purpose of speaking with our residents about, in this case, Elections, or it might be our Sheriff or it might be the Clerk of Court, it could be the Tax Collector, whomever the Constitutional Officers are; and I think even maybe a Chief Justice – that we provide a forum for them to come in and conduct that type of a meeting; and it is at our request and our invite to them, and that way we can push it out on our social media."

Mayor Lacey then said, "Let me follow that through - so, the next step then would be to make that invitation to Mr. Anderson - on our terms, as opposed to his, and ask him to come participate and then when that is done, we would look for the next opportunity down the road."

Deputy Mayor Cannon stated, "Yes, exactly. And, so we may next reach out to - the Property Appraiser, it could be the Tax Collector, it could be the Clerk of Courts, it could be the Sheriff; and maybe even the Chief Judge of the Circuit Court to come in and address - the court system and things like that. I think these types of City forums with the invites to these various very important segments of our County are very helpful; and if we extend the invite, and they are our invited guests then that resolves any concerns."

Commissioner Kendrick remarked, "I think that is a fine idea - invite any of the five (5) Constitutional Officers to our City at any time really – if Staff can work out the logistics. I think certainly, starting with Chris Anderson because he has prompted the interest; I think we should just have Staff look at maybe when the – Agenda is maybe a little bit lighter, because sometimes we have heavy Agendas, sometimes we have lighter ones in the next couple of months - invite Chris Anderson sooner rather than later probably to one, and just have a lighter Agenda that evening, whenever it works best for Staff, and that would be a good starting point; and then figure out the logistics from there."

Comments followed on what Mr. Anderson had originally requested. Mayor Lacey pointed out that Mr. Anderson originally asked to use the building.

Commissioner Johnson noted, "If that was his request, then by all means I think we should invite him in. So, we just need to coordinate with him when that will take place, we advertise it..." Mayor Lacey added, "...And then assess how it goes and then follow up on the Deputy Mayor's suggestion..." Commissioner Johnson stated, "...Absolutely..." Mayor Lacey added, "...And repeat..." Commissioner Kendrick remarked, "Agreed."

Deputy Mayor Cannon suggested, "A Town Hall meeting, we extend an invitation starting with Mr. Anderson, and then going to others, like every couple of months."

Mayor Lacey noted, "Deputy Mayor, everybody up here is nodding."

City Clerk Lorenzo-Luaces then referenced an email from Mr. Anderson.

Commissioner Kendrick asked if the Elected Officials could attend if they wanted to, and with further brief comments, it was stated that the Commission would not be on the dais, it would be Mr. Anderson presenting to any attendees.

### **603. Seat Four Commissioner TiAnna Hale**

---

Commissioner Hale complimented Mr. Caldwell, Ms. Melissa Sileo, Program Coordinator, Special Events and Recreation Programs, Parks and Recreation Department, and Staff on the great 4<sup>th</sup> of July event.

Next, Commissioner Hale referenced the dance studio in the Winter Springs Town Center and noted that they were now National Champions and offered her congratulations.

Commissioner Hale noted that she had found out about a downed tree on Shepard Road and before she could do anything, Mr. Rafael Diaz, Field Team Leader, Public Works Department and Staff had cleaned up the area. Commissioner Hale said she was very impressed with their very prompt and helpful service.

#### **604. Seat Five Commissioner Geoff Kendrick**

---

Commissioner Kendrick agreed with Commissioner Hale regarding the great “Celebration of Freedom” event and added, “Our Team is second to none.”

Next, Commissioner Kendrick referenced the recent Business Visioning Session and suggested that the City Commission could talk about what was discussed; and that one of the items addressed dealt with parking at the Town Center. Commissioner Kendrick suggested that he thought a re-design and/or re-bid would help with what options were available. Interim Manager Boyle noted, “We’ve started the process.”

#### **605. Mayor Charles Lacey**

---

No Report.

#### **606. Seat One Commissioner Jean Hovey**

---

Commissioner Hovey also mentioned the super “Celebration of Freedom” event. Comments followed on who in past years had been invited to the event’s hospitality tent, and new procedures. Interim Manager Boyle said it was up to the Mayor and City Commission who should be invited and recommended, “Just direct us – who you would like to bring and we’ll make it happen.”

With further remarks, Commissioner Hovey noted, “Going forward, if there is a VIP tent, it is for the sponsors and for the Commissioners, and if we want to invite someone, we should let you or Shawn (Boyle) know who we would like to invite.” Mr. Caldwell responded, “Absolutely, and you can even let us know how many passes you’d like in advance and we’ll make them available.”

Next, Commissioner Hovey noted that the deadline for City Manager Applications was August 1, that the City Commission would not meet again until after that deadline and asked how the process would proceed.

Discussion ensued that some Applicants were not qualified, that a specific time to discuss applications was needed, and would Attorney Garganese and/or Ms. Casey Howard, Director, Administrative Services be pre-selecting Applicants.

Deputy Mayor Cannon noted, "My preference Commissioner Hovey would be for Anthony (Garganese) and Casey (Howard) to at least do a preliminary cut, a preliminary sort on them." Deputy Mayor Cannon added, "I would like for them to present us with their recommended short-list if you will, of Applicants, and then we look at it. If any one of us feels like there should be another name added – then we would have that opportunity and then I really would like for the reference checks and all the rest of that to be done by Anthony (Garganese) and by City Staff."

Further, Deputy Mayor Cannon added that when the City Commission have been provided with a narrowed list and background verifications have been completed, a Special Meeting would be needed. Commissioner Kendrick stated, "I agree with Deputy Mayor."

Mayor Lacey thought that if the Applicants were divided into categories and the Elected Officials disagreed with any choices, then the Mayor and City Commission could suggest alternative Applicants.

Commissioner Hovey noted, "I've already seen a couple that I think that we should look at; so, we can go through and make that recommendation or wait until we get the recommendations from Casey (Howard) and Anthony (Garganese)."

Mayor Lacey said, "You use whatever criteria you personally want to use and their input to you may be useful, it may not."

Comments continued.

Mayor Lacey asked the City Commission, "Is there agreement that you do want to have a Special Meeting?" Commissioner Hovey responded, "I agree." With no objections voiced, discussion followed on possible dates.

Ms. Howard said she would make sure she was available and inquired, "Will the Commission be suggesting who they want me to do the reference checks for, in addition to the top candidates that Anthony (Garganese) and I..." Deputy Mayor Cannon remarked, "...My preference would be for Casey (Howard) and Anthony (Garganese) at the next Commission Meeting to give us their shortlist, if you will." Deputy Mayor Cannon added, "If any of us had an additional name in mind that we would present that as well, and then that would give them enough time to do the background and reference checks."

Further discussion followed on a short list and dates to which Wednesday, August 21<sup>st</sup>, 2019 was suggested. Deputy Mayor Cannon stated, "That would work for me." Mayor Lacey then asked, "Any dissent to the 21<sup>st</sup>?" With no objections noted, Mayor Lacey summarized, "Let us set it for the 21<sup>st</sup> [of August]"

Deputy Mayor Cannon said he thought the meeting should start at 6:30 p.m. No dissent was voiced. Deputy Mayor Cannon then asked, "That will give you enough time Casey (Howard) to do what you need to do in checking references and Anthony (Garganese) so you can report back to us, right?" Ms. Howard responded, "Yes."

Discussion followed on individual Commissioners providing Ms. Howard with names of Applicants they were interested in, and that reference checks would not be done until after the closing date.

Next, in terms of earlier comments regarding the hospitality tent at the recent "Celebration of Freedom" event, Commissioner Hale asked if we could look at the costs related to the hospitality tent.

### **607. Seat Two Commissioner/Deputy Mayor Kevin Cannon**

Deputy Mayor Cannon offered his thanks to the City's Police Department, Seminole County Fire, as well City employees including the Parks and Recreation Department staff on their many months of preparation for the great Fourth of July event.

Mayor Lacey noted that he agreed.



## **608. Seat Three Commissioner Ted Johnson**

---

Commissioner Johnson noted the next Florida League of Cities Policy meetings were scheduled for July 19<sup>th</sup>.

Next, Commissioner Johnson mentioned that he attended the recent EOC (Emergency Operations Center) test run, thanked Chief Deisler on the great job and was appreciative of the plans for better communications.

Chief Deisler briefly responded.

Next, Commissioner Johnson pointed out that he attended a recent Seminole County Commission meeting which dealt with rental properties including Airbnb's and that the Seminole County Commission chose not to impose more regulations.

Continuing his Report, Commissioner Johnson noted that he attended a City Code Enforcement Board in late June and thanked the Board Members for their service.

Lastly, Commissioner Johnson offered his appreciation to Mr. Caldwell and Mr. Mike Barclay, Recreation Superintendent, Parks and Recreation Department for assisting Winter Springs' resident and World War II Veteran, Mr. Emil Abrahamian with his art display at the "Celebration of Freedom" event; and noted that Mr. Abrahamian had said that it was one of the best days of his life.

Commissioner Kendrick further briefly addressed Vacation Rentals and also noted that he was looking forward to the City Commission's Board and Committee Appreciation Dinner which would be held on July the 26<sup>th</sup> [2019].

## **PUBLIC INPUT**

*Mayor Lacey opened "Public Input".*

No one spoke.

*Mayor Lacey closed "Public Input".*

## **ADJOURNMENT**

Mayor Lacey adjourned the Regular Meeting at 9:40 p.m.

*RESPECTFULLY SUBMITTED:*

---

ANDREA LORENZO-LUACES, MMC  
CITY CLERK

*APPROVED:*

---

MAYOR CHARLES LACEY

NOTE: These Minutes were approved at the \_\_\_\_\_, 2019 City Commission Regular Meeting.



# PUBLIC HEARINGS AGENDA ITEM 400

CITY COMMISSION REVISED AGENDA  
AUGUST 12, 2019 | REGULAR MEETING

## TITLE

Public Adoption Hearing and Second Reading of Ordinance 2019-06 regarding EAR based amendments to the Comprehensive Plan related to the Intergovernmental Coordination Element and transmit to the Department of Economic Opportunity and other reviewing agencies

## SUMMARY

Effective June 2, 2011, local governments have more discretion in determining whether they need to update their local comprehensive plan. As such, local governments no longer need to submit evaluation and appraisal reports to the department for a sufficiency determination. Instead, local governments must follow these new provisions:

1. At least every seven years, pursuant to Rule Chapter 73C-49, Florida Administrative Code, **determine whether the need exists to amend the comprehensive plan to reflect changes in state requirements since the last time the comprehensive plan was updated.**
2. Notify the state land planning agency by letter of this determination.
3. If the local government determines amendments to the comprehensive plan are necessary, the local government shall prepare and transmit the proposed amendments to the State Land Planning Agency within one year of such determination. For guidance and more information about these processes, see
4. Any local government failing to timely submit a notification letter or proposed amendments within one year of notification may not amend its comprehensive plan until it complies with the requirements.
5. The evaluation and appraisal should address changes in state requirements since the last update of the comprehensive plan and update the plan based on changes to local conditions.

The attached documents include EAR (Evaluation and Appraisal Report) based Comprehensive Plan amendments, specifically to the Intergovernmental Coordination Element. **The purpose of the proposed Ordinance and related amendments is to update the Intergovernmental Coordination Element to reflect changes in state requirements since the last time the comprehensive plan was updated.** Subsequent EAR based amendments to other Comprehensive Plan Elements will follow in the next few months during upcoming public hearings in order to reflect changes in state requirements.

The Local Government Comprehensive Planning Act requires local comprehensive plans to be consistent with the goals of the state and regional policy plans. Local governments need to provide for this consistency in the goals, objectives, and policies of their comprehensive plans.

The City's interpretation of the legislative intent of the consistency requirement is to provide for all comprehensive plans, adopted locally, to coordinate into a statewide framework for "growth management." One tool that the Act mandated to meet this legislative intent was for local comprehensive plans to adopt an Intergovernmental Coordination Element.

In order to provide for this consistency, coordination among state, regional, and local governments and agencies is essential. This coordination provides not only the method for the plans to be consistent, but also allows for more efficient delivery of services to the City residents. Mechanisms to meet this consistency requirement include, but are not limited to:

- Intergovernmental agreements
- Joint planning and service agreements
- Special legislation
- Joint meetings, public hearings
- Work groups or governmental programs designed to further intergovernmental coordination

In addition, this Element can act as a catalyst for the smooth operation of the rest of the plan elements. By defining and creating tests of consistency within this Element, deficiencies within and among elements can be identified for the purpose of correcting them.

This Element can also be used as a mechanism to provide direction to the City for future implementation of federal, state, and regional programs, grants and assistance. Numerous government programs exist which can be used by the City in the implementation of the City's Comprehensive Plan. In addition, these programs can be used to meet the growing demands of the population growth on the City's services and public infrastructure.

The revised language will allow the Element to come into compliance with the Evaluation and Appraisal Report that was due in 2017.

On April 3, 2019, the City's Land Planning Agency unanimously recommended approval of Ordinance No. 2019-06.

On April 22, 2019, the City Commission unanimously approved the transmittal of Ordinance No. 2019-06 to the Department of Economic Opportunity (DEO)

On July 1, 2019, the Department of Economic Opportunity (DEO) completed its review and provided Objections, Recommendations, and Comments Report to the City.

### Proposed Timeline

1. March 24, 2019 Ad runs in Orlando Sentinel (10 days prior to LPA)
2. **April 3, 2019 Local Planning Agency/Planning & Zoning Board**
3. **April 22, 2019 City Commission - 1<sup>st</sup> Reading/Transmittal**
4. May 1, 2019 Transmit to Dept. of Economic Opportunity
5. May 3, 2019 Dept. of Economic Opportunity Receipt Confirmation
6. August 2, 2019 Adoption Ad runs in Orlando Sentinel
7. **August 12, 2019 City Commission - 2<sup>nd</sup> Reading/Adoption**
8. August 26, 2019 Adopted Plan Amendment submittal to State
9. August 28, 2019 Dept. of Economic Opportunity Receipt Confirmation
10. September 29, 2019 Effective Date (no petitions filed)

### **RECOMMENDATION**

Staff recommends that the City Commission Approve the Second Reading/Adoption Hearing and Adoption of Ordinance 2019-06, an Expedited State Review (Large Scale Comprehensive Plan Amendment) amending the Comprehensive Plan related to the Intergovernmental Coordination Element.

**ORDINANCE NO. 2019-06**

**A ORDINANCE OF THE CITY COMMISSION OF THE CITY OF WINTER SPRINGS, SEMINOLE COUNTY, FLORIDA, SETTING FORTH AMENDMENTS TO THE CITY OF WINTER SPRINGS COMPREHENSIVE PLAN, INTERGOVERNMENTAL COORDINATION ELEMENT BASED ON THE CITY'S EVALUATION AND APPRAISAL OF THE COMPREHENSIVE PLAN PURSUANT TO SECTION 163.3191, FLORIDA STATUTES; PROVIDING FOR THE REPEAL OF PRIOR INCONSISTENT ORDINANCES AND RESOLUTIONS; INCORPORATION INTO THE COMPREHENSIVE PLAN; LEGAL STATUS OF THE COMPREHENSIVE PLAN AMENDMENTS; SEVERABILITY; AND AN EFFECTIVE DATE.**

**WHEREAS**, the Florida Legislature intends that local planning be a continuous and ongoing process; and

**WHEREAS**, section 163.3161 et. seq., Florida Statutes, established Community Planning Act; and

**WHEREAS**, consistent with the Community Planning Act, the City Commission has adopted the City of Winter Springs Comprehensive Plan; and

**WHEREAS**, as required by section 163.3191, Florida Statutes, the City has conducted an evaluation of its Comprehensive Plan, Intergovernmental Coordination Element, to determine if plan amendments are necessary to reflect changes in state requirements since the last update of the City's Comprehensive Plan, which is required to be adopted every seven (7) years to assess the progress of implementing the City's Comprehensive Plan; and

**WHEREAS**, the Local Planning Agency has reviewed the amendments to the Comprehensive Plan, Intergovernmental Coordination Element, set forth herein, held an advertised public hearing, provided for participation by the public in the process, and rendered its recommendations to the City Commission; and

**WHEREAS**, the City Commission, after considering the Local Planning Agency's review comments and recommendations for amendments to the Intergovernmental Coordination Element, desires to adopt the amendments set forth herein; and

**WHEREAS**, the City Commission of the City of Winter Springs, Florida, hereby finds this

ordinance to be in the best interests of the public health, safety, and welfare of the citizens of Winter Springs.

**NOW, THEREFORE, THE CITY COMMISSION OF THE CITY OF WINTER SPRINGS HEREBY ORDAINS, AS FOLLOWS:**

**Section 1. Recitals.** The foregoing recitals are true and correct and are fully incorporated herein by this reference.

**Section 2. Authority.** This Ordinance is adopted in compliance with, and pursuant to, the Community Planning Act, Sections 163.3184 and 163.3191, Florida Statutes.

**Section 3. Purpose and Intent.** The purpose and intent of this ordinance is to adopt text amendments to the City's Comprehensive Plan as set forth herein, which are based on the City's evaluation and appraisal of the Comprehensive Plan pursuant to Section 163.3191, Florida Statutes.

**Section 4. Adoption of Text Amendments to the Comprehensive Plan, Intergovernmental Coordination Element.** The Winter Springs Comprehensive Plan, Intergovernmental Coordination Element is hereby amended only as specifically enumerated and set forth in **Exhibit "A"** attached hereto and fully incorporated herein by this reference. (Underlined type indicates additions and ~~strikeout~~ type indicates deletions). It is intended that the text in the Comprehensive Plan not specifically enumerated and set forth in this Exhibit shall remain unchanged from the language existing prior to adoption of this Ordinance).

**Section 5. Transmittal to the Department of Economic Opportunity.** The City Manager or his designee is hereby designated to sign a letter transmitting the adopted Comprehensive Plan Amendment to the Florida Department of Economic Opportunity for expedited state review, in accordance with Section 163.3184(2), Florida Statutes.

**Section 6. Repeal of Prior Inconsistent Ordinances and Resolutions.** All prior inconsistent ordinances and resolutions adopted by the City Commission of the City of Winter Springs, or parts of ordinances and resolutions in conflict herewith, are hereby repealed to the extent of the conflict.

**Section 7. Severability.** If any section, subsection, sentence, clause, phrase, word or provision of this Ordinance is for any reason held invalid or unconstitutional by any court of competent jurisdiction, whether for substantive, procedural, or any other reason, such portion shall be deemed a separate, distinct and independent provision, and such holding shall not affect the validity of the remaining portions of this Ordinance.

**Section 8. Incorporation Into Comprehensive Plan.** Upon the effective date of the Comprehensive Plan Amendments adopted by this Ordinance, said Amendments shall be incorporated into the City of Winter Springs Comprehensive Plan and any section or paragraph



number or letter and any heading may be changed or modified as necessary to effectuate the foregoing.

**Section 9. Effective Date and Legal Status of the Plan Amendment.** The effective date of the Comprehensive Plan Amendments adopted by this Ordinance shall be 31 days after the Florida Department of Economic Opportunity notifies the City that the plan amendment package is complete or, if timely challenged, the date the Florida Department of Economic Opportunity or the Administration Commission enters a final order determining the adopted amendment to be in compliance as defined in section 163.3184, Florida Statutes. No development orders, development permits, or land use dependent on these Amendments may be issued or commenced before it has become effective. If a final order of noncompliance is issued by the Administration Commission, the Amendments may nevertheless be made effective by adoption of a resolution affirming its effective status. After and from the effective date of these Amendments, the Comprehensive Plan Amendments set forth herein shall amend the City of Winter Springs Comprehensive Plan and become a part of that plan and the Amendments shall have the legal status of the City of Winter Springs Comprehensive Plan, as amended.

**ADOPTED** by the City Commission of the City of Winter Springs, Florida, in a regular meeting assembled on the \_\_\_\_\_ day of \_\_\_\_\_, 2019.

\_\_\_\_\_  
**Charles Lacey, Mayor**

**ATTEST:**

\_\_\_\_\_  
**Andrea Lorenzo-Luaces, City Clerk**

Approved as to legal form and sufficiency for  
the City of Winter Springs only:

\_\_\_\_\_  
**Anthony A. Garganese, City Attorney**

Transmittal \_\_\_\_\_ Hearing: \_\_\_\_\_  
Adoption Hearing: \_\_\_\_\_  
Effective Date: \_\_\_\_\_

# WHAT'S HAPPENING

Continued from Page J3

407-254-9231.

**Woodstock 50th Anniversary:** Celebrate with UCF Professor George Weremchuk. Relive the three days of peace and music with songs and video clips from the first real music festival. 6:30 p.m. Aug. 15, Orlando Public Library, 101 E. Central Blvd., Orlando, free, 407-835-7323.

**Christine MacPhail:** A musical performance by Central Florida harpist Christine MacPhail. 11 a.m. Aug. 17, Orlando Public Library, 101 E. Central Blvd., Orlando, free, 407-835-7323.

**Money Management Using a Calendar:** Presented by UF/IFAS Extension - Family and Consumer Sciences. Advance registration required. 2-3 p.m. Aug. 20, North Orange branch of the Orange County Library System, 1211 E. Semoran Blvd., Apopka, free, 407-254-9231.

**Introduction to Calligraphy:** Learn about the origins of calligraphy and get introduced to some materials used to create it. Practice using this form of writing to create endless projects. Advance registration required. 11 a.m.-12:30 p.m. Aug. 24, Herndon branch of the Orange County Library System, 4324 E. Colonial Drive, Orlando, free, 407-835-7323.

**No Tan Radio Music & Arts Festival:** The festival focuses on independent Hispanic/Latin musicians and visual artists. Noon Aug. 24, Orlando Public Library, 101 E. Central Blvd., Orlando, free, 407-835-7323.

**Container Gardening:** Join Master Gardener Dena Wild from the UF/IFAS Extension Orange County Office for tips on starting your own container garden. Learn the many advantages of container gardening. 7 p.m. Aug. 28, Herndon branch of the Orange County Library System, 4324 E. Colonial Drive, Orlando, free, 407-835-7323.

**Introduction to Calligraphy:** Learn about the origins of calligraphy and get introduced to some

materials used to create it. Practice using this form of writing to create endless projects. Advance registration required. 11 a.m.-12:30 p.m. Aug. 31, West Oaks branch of the Orange County Library System, 1821 E. Silver Star Road, Ocoee, free, 407-835-7323.

**One Minute Film Festival:** Screenings of one minute films that capture the world we love to live in. Coffee and donuts provided, while supplies last. 11 a.m.-1 p.m. Aug. 31, Orlando Public Library, 101 E. Central Blvd., Orlando, free, 407-835-7323.

## Social/Hobby Clubs

**Florida Cabin Fever Quilt Guild:** Visitors interested in quilting welcome. Howard Vincent Kurtz will give a presentation about color selection. 6-8 p.m. Aug. 5, Marks Street Senior Center Recreation Complex, 99 E. Marks St., Orlando, free, 407-282-1871.

**Central Florida Railway Historical Society:** Ken Murdock will discuss the Jacksonville, Tampa and Key West Railway. 7 p.m. Aug. 12, Central Florida Railroad Museum, 101 S. Boyd St., Winter Garden, free, 407-656-0559.

**Apopka Gesneriad and African Violet Society:** Meetings include a gesneriad show followed by program highlighting a particular genera. 3-5 p.m. the second Sunday of the month (except May which meets on 3rd Sunday), First United Methodist Church of Apopka, 201 S. Park Ave., Apopka, free, 407-654-0949.

**Orlando Society of Model Railroaders:** See a large, fully operational HO scale model railroad with eight scale miles of main line track and fully detailed areas of urban and rural scenery. Visitors are welcome and memberships are available for those who would be interested in participating in club activities regularly. 6-9 p.m. Tuesdays, 9:30 a.m.-3:30 p.m. Saturdays, Orlando Society of Model Railroaders, 7208 Aloma Ave., No. 500,

Winter Park, 407-496-8225.

**Scribes of Central Florida Calligraphy Guild:** Open to all who are interested or want to learn more about calligraphy. 1 p.m. the first Sunday of each month September through May, Roth Jewish Community Center of Greater Orlando, 851 N. Maitland Ave., Maitland, free, 407-603-0214.

**Central Florida Stamp Club:** 6-9 p.m. the first and third Thursdays of the month, Marks Street Senior Recreation Complex, 99 E. Marks St., Orlando, free, 407-889-0528.

**Italian American Social Club of Central Florida:** General meeting, 7:30 p.m. the second Wednesday of every month; board meeting, 7:30 p.m. the first Wednesday of every month; dinner dances, with live bands, 6-10 p.m. every second and fourth Saturday (\$30 for members, \$35 for guests, includes open bar); Italian American Social Club of Central Florida, 5900 Hibiscus Road, Orlando, 407-273-2830.

**Central Florida Fruit Society:** Discover new species and varieties of ambrosial fruits from around the world and grown locally. 6:30-9 p.m. the third Monday of the month (except July), Harry P. Leu Gardens 1920 N. Forest Ave., Orlando, free, 407-995-6717.

**'Sew Crazies':** Orlando Chapter neighborhood group of American Sewing Guild. Dedicated to advancing sewing as an art and life skill. All levels welcome. First two visits are free, then ASG membership is required. 10 a.m. the second Monday of the month, The Sewing Studio, 9605 U.S. Highway 17-92, Maitland, 407-697-0882.

**Central Florida Coin Club:** Weekly presentations. 7 p.m. the second and fourth Wednesdays of the month, Marks Street Senior Recreation Complex, 99 E. Marks St., Orlando, free, 407-657-6440.

*Joseph Rassel of the Sentinel staff compiled this report. To submit an item email communityevents@orlandosentinel.com.*



# Special subscriber message

Your subscription includes Unlimited Digital Access

Simply activate your digital account to get the latest stories online, our app with breaking news alerts and the eNewspaper, a digital edition of our paper, emailed daily.

Activating only takes a minute, so do it now!

Go-Activate.com

THE BALTIMORE SUN | Chicago Tribune | Daily Press  
Hartford Courant | THE MORNING CALL | DAILY NEWS  
Orlando Sentinel | SunSentinel | The Virginian-Pilot

## CITY OF CASSELBERRY, FLORIDA NOTICE OF PUBLIC HEARING TO CONSIDER PROPOSED ORDINANCE FOR UNIFIED LAND DEVELOPMENT REGULATIONS AMENDMENTS

TO WHOM IT MAY CONCERN:

**NOTICE IS GIVEN** by the City of Casselberry, Florida, that the Planning and Zoning Commission, acting as the Local Planning Agency (LPA), will hold a public hearing to consider enactment of an Ordinance entitled:

LPA 19-13

**AN ORDINANCE OF THE CITY OF CASSELBERRY, FLORIDA, AMENDING THE CITY UNIFIED LAND DEVELOPMENT REGULATIONS, CHAPTER II, DISTRICT AND GENERAL REGULATIONS, ARTICLE VII, GENERAL REGULATIONS, ADDING SECTION 2-7.37, HOTELS, MOTELS, AND TRANSIENT LODGING, FOR LODGING STANDARDS, AND AMENDING CHAPTER V, GLOSSARY, ARTICLE XXI, LANGUAGE AND DEFINITIONS, SECTION 5-21.2, DEFINITION OF TERMS, ADDING AND UPDATING DEFINITIONS FOR LODGING TYPES; PROVIDING FOR CODIFICATION, CONFLICTS, SEVERABILITY AND AN EFFECTIVE DATE.**

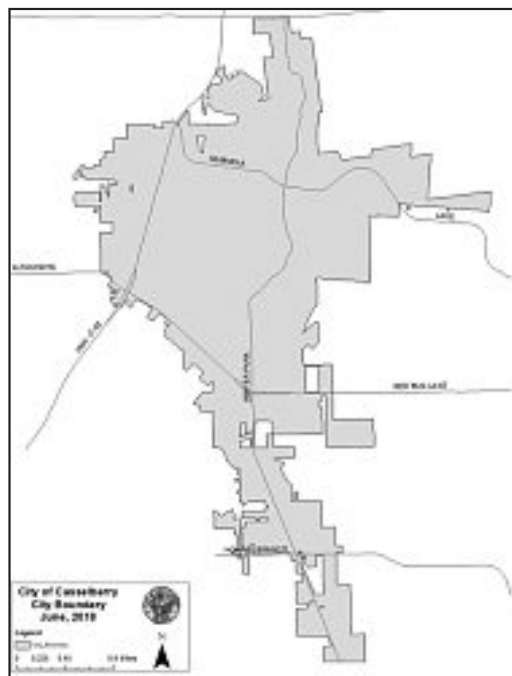

This notice is pursuant to the provisions of Chapter 166, Florida Statutes, and the Charter and Ordinances of the City of Casselberry, Florida, as amended and supplemented.

The Planning and Zoning Commission will consider the proposed Ordinance on **Wednesday, August 14, 2019 at 6:30 p.m.** or as soon thereafter as possible, in the Casselberry City Hall Commission Chambers, 95 Triplet Lake Drive, Casselberry, Florida. At the meeting, interested parties may appear and be heard with respect to the proposed Ordinance. This hearing may be continued from time to time until final action is taken by the Commission. Copies of the proposed Ordinance are available at City Hall with the City Clerk and the same may be inspected by the public.

Publish Date: August 4, 2019 Donna G. Gardner, CMC, City Clerk

Please be advised that one (1) or more members of the City Commission may be in attendance and may participate in the discussions at the meeting.

"Persons are advised that, if they decide to appeal any decision made at these meetings/hearings, they will need a record of the proceedings and for such purpose, they may need to insure that a verbatim record of the proceedings is made, which record includes the testimony and evidence upon which the appeal is to be based, per Section 286.0105, Florida Statutes."  
"Persons with disabilities needing assistance to participate in any of these proceedings should contact the A.D.A. Coordinator 48 hours in advance of the meeting at (407) 262-7700 Ext. 1150."

## NOTICE OF HEARING TO IMPOSE AND PROVIDE FOR COLLECTION OF NON-AD VALOREM SPECIAL ASSESSMENTS

SAUSALITO SHORES SUBDIVISION  
CASSELBERRY, FLORIDA



Proposed Non-ad Valorem Special Assessment Area  
Proposed Location of Sausalito Shores Subdivision Wall

Notice is hereby given that the City Commission of Casselberry, Florida, will conduct a public hearing to consider creation of the Sausalito Assessment Area, as shown above, and to impose non-ad valorem special assessments against certain property located therein and collecting the assessments on the ad valorem tax bill. The hearing will be held at 5:00 P.M. on August 26, 2019, in the City Commission Chambers of City Hall at 95 Triplet Lake Drive, Casselberry, Florida. All affected property owners have a right to appear at the hearing and to file written objections with the City Commission within 20 days of this notice. If you decide to appeal any decision made by the City Commission with respect to any matter considered at the hearing, you will need a record of the proceedings and may need to ensure that a verbatim record is made, including the testimony and evidence upon which the appeal is to be made. In accordance with the Americans with Disabilities Act, if you need a special accommodation or an interpreter to participate in this proceeding, please contact the City Clerk's office at (407) 262-7700 ext. 1133 at least 48 hours prior to the date of the hearing.

The assessments have been proposed to fund capital costs for construction of a replacement privacy wall to serve the Sausalito Assessment Area. The project to construct the privacy wall is referred to as the Sausalito Shores Subdivision Wall. The assessment for each parcel of property within the Sausalito Assessment Area will be based on "Benefit Units." Each single family platted in the Sausalito Assessment Area will be assigned one (1) Benefit Unit. A more specific description of the project and the special assessment is set forth in the Initial Assessment Resolution adopted by the City Commission on July 22, 2019. Copies of the Initial Assessment Resolution, the preliminary plans and specifications for the project, and the preliminary assessment roll are available for inspection at the offices of the City Clerk, located at 95 Triplet Lake Drive, Casselberry, Florida.

Annual capital assessments to fund the Sausalito Shores Subdivision Wall will be collected in annual installments on the ad valorem tax bill mailed by the county tax collector for a period of up to twenty (20) years, commencing with the tax bill to be mailed in November 2019. The assessments will be collected by the tax collector and failure to pay the assessments will cause a tax certificate to be issued against the lot, which may result in a loss of title. If you have any questions, please contact the City Manager's office at (407) 262-7700 ext. 1130.

## NOTICE OF PUBLIC HEARING CITY OF WINTER SPRINGS

NOTICE IS HEREBY GIVEN THAT  
THE CITY COMMISSION  
PROPOSE TO CONSIDER THE FOLLOWING:

ORDINANCE 2019-06

**AN ORDINANCE OF THE CITY COMMISSION OF THE CITY OF WINTER SPRINGS, SEMINOLE COUNTY, FLORIDA, SETTING FORTH AMENDMENTS TO THE CITY OF WINTER SPRINGS COMPREHENSIVE PLAN, INTERGOVERNMENTAL COORDINATION ELEMENT BASED ON THE CITY'S EVALUATION AND APPRAISAL OF THE COMPREHENSIVE PLAN PURSUANT TO SECTION 163.3191, FLORIDA STATUTES; PROVIDING FOR THE REPEAL OF PRIOR INCONSISTENT ORDINANCES AND RESOLUTIONS; INCORPORATION INTO THE COMPREHENSIVE PLAN AMENDMENTS; SEVERABILITY; AND AN EFFECTIVE DATE.**

**CITY COMMISSION SECOND READING PUBLIC HEARING WILL BE HELD ON MONDAY, AUGUST 12, 2019 AT 6:30 P.M. OR SOON THEREAFTER IN THE COMMISSION CHAMBERS LOCATED AT WINTER SPRINGS CITY HALL 1126 EAST STATE ROAD 434 WINTER SPRINGS, FLORIDA**

The proposed ordinance may be obtained by interested parties between 8 a.m. and 5 p.m., Monday through Friday, from the office of the City Clerk, located at 1126 E. SR 434, Winter Springs, Florida. For more information, call (407) 327-1800 #227. Persons with disabilities needing assistance to participate in any of these proceedings should contact the Employee Relations Department Coordinator, 48 hours in advance of the meeting at (407) 327-1800, #236. This is a public hearing. Interested parties are advised that they may appear at the meeting and be heard with respect to the proposed ordinance. If you decide to appeal any recommendation or decision made by the City Commission with respect to any matter considered at this meeting, you will need a record of the proceedings, and for such purposes, you may need to ensure that a verbatim record of the proceedings is made upon which the appeal is based.

**TABLE OF CONTENTS**

**A. GOALS, OBJECTIVES, AND POLICIES .....1**

**B. INTRODUCTION.....7**

**C. INVENTORY OF EXISTING INTERGOVERNMENTAL COORDINATION MECHANISMS .....7**

**1. Local.....7**

    a. Seminole County School Board (School Board) .....[87](#)

    b. Seminole County ..... 9

    c. Other Local Agencies ..... 10

**2. Regional..... 11**

    a. East Central Florida Regional Planning Council (ECFRPC)..... 11

    b. METROPLAN ORLANDO ..... 12

    c. St. Johns River Water Management District (SJRWMD)..... 12

**3. State ..... [1413](#)**

    a. Department of ~~Economic Opportunity Community Affairs~~ (DCADEO)..... 14

    b. Florida Department of Transportation (FDOT) ..... 15

    c. Department of Environmental Protection (FDEP).....[1615](#)

    d. Florida Fish and Wildlife Conservation Commission (FFWCC)..... 16

    e. Florida Department of Agriculture and Consumer Services (FDACS)..... 16

    f. Department of State, Division of Historical Resources (DHR) .....[1746](#)

**4. Federal ..... [1716](#)**

    a. U.S. Environmental Protection Agency (EPA) ..... 17

    b. U.S. Department of Agriculture (USDA) .....[1817](#)

    c. U.S. Army Corps of Engineers (ACOE) ..... 18

    d. U.S. Housing and Urban Development (HUD) ..... 18

    e. U.S. Flood and Emergency Management Agency (FEMA)..... 18

**5. Utilities ..... 19**

    a. Electric ..... 19

    b. Sanitary Sewer, Potable Water and Reclaimed Water ..... 19

    c. Telephone .....[2019](#)

    d. Cable Television .....[2019](#)

e. Solid Waste Collection.....20

f. Gas Service .....20

**D. ANALYSIS FOR IMPROVEMENTS TO INTERGOVERNMENTAL COORDINATION.....20**

**1. Intergovernmental Mechanism Opportunities and Problem Areas .....20**

a. Local (Ord. 2007-22; 01-14-2008).....20

b. Regional.....[2221](#)

c. State .....[2322](#)

d. Federal.....23

**2. Future Growth and Development and the Role of Intergovernmental Coordination ....23**

**3. Areas of Critical State Concern ..... [2423](#)**

**LIST OF TABLES**

**Table VIII - 1: Intergovernmental Coordination Contacts.....24**

**Table VIII - 2: Inventory of Existing Interlocal Agreements.....26**



---

CHAPTER VIII  
INTERGOVERNMENTAL COORDINATION ELEMENT

**A. GOALS, OBJECTIVES, AND POLICIES**

**GOAL 1:** The City seeks to promote and implement stable working relationships with other governmental agencies to ensure efficient, effective, and thorough delivery of governmental services.

**Objective 1.1: *Coordination of Plans.*** The City shall coordinate its Comprehensive Plan with the State Comprehensive Plan, East Central Florida Regional Policy Plan, Seminole County Comprehensive Plan, and adjacent city comprehensive plans. (Ord. 2007-22; 01-14-2008)

- Policy 1.1.1:** Coordinate with affected governmental agencies when developments requiring Chapter 380, Florida Statutes, review are within the City's jurisdiction.
- Policy 1.1.2:** Review the Seminole County and adjacent city comprehensive plans to determine the impact of those adopted plans on the future growth and development of the City whenever comprehensive plan changes are proposed by those jurisdictions.
- Policy 1.1.3:** Participate in the Regional Policy Plan review and update processes as mandated by state statute.
- Policy 1.1.4:** Transmit advance notification of requests for land use, zoning and development approvals to Seminole County, School Board and adjacent cities that may be affected, as required by the *Intergovernmental Planning Coordination Agreement of 1997*.
- Policy 1.1.5:** Coordinate with the resource protection efforts of the St. Johns River Water Management District (SJRWMD) for Lake Jesup and participate in the implementation efforts and development of strategies to improve water quality, such as the SJRWMD ~~January 2002 Surface Water Improvement and Management~~ 2002 Middle St. Johns River Basin Surface Waters Improvement and Management (SWIM) plan, the *2008 Lake Jesup Interagency Restoration Strategy*, and the 2010 Lake Jesup Basin Management Action Plan ~~currently under development~~.
- Policy 1.1.6:** Update and coordinate the City's Water Supply Work Plan (Exhibit IV-B-1) with the *Seminole County's Water Supply Plan 20107*, ~~SJRWMD's District Water Supply Plan 2005 and 2006 Addendum~~ the 2015 Central Florida Water Initiative Regional Water Supply Plan (CFWI RWSP) and the East Central Florida Regional

Planning Council (ECFRPC)'s *Strategic Regional Policy Plan* ~~1998~~2013. (Cross Reference: See Conservation Element, Policy 1.2.~~89~~)

- Policy 1.1.7:** Coordinate any proposed amendments to the City's Public School Facilities Element with the other local jurisdictions within Seminole County, so that the Element remains consistent with those of the other local jurisdictions and with the *2007 Interlocal Agreement for Public School Facility Planning and School Concurrency As Amended January 2008*, as required by Florida Statute.
- Policy 1.1.8:** Actively participate in the Planning Technical Advisory Committee (PTAC), as provided in the *2007 Interlocal Agreement for Public School Facility Planning and School Concurrency As Amended January 2008*, for the purpose of discussing issues and formulating recommendations to the Public Schools Facilities Planning Committee (PSFPC) regarding coordination of land use and school facilities planning (including such issues as population and student projections, development trends, school needs, co-location and joint use opportunities, ancillary infrastructure improvements needed to support the schools, School Board Five-Year Capital Improvement Plan and the Public School Concurrency Program). (Cross Reference: See Public School Facilities Element, Policy 1.3.3)
- Policy 1.1.9:** Continue to use intergovernmental coordination committees such as the PTAC to ensure consistency between comprehensive planning programs and issues of adjacent municipalities and Seminole County.

**Objective 1.2: Land Use and Housing Coordination.** The City shall coordinate with affected governmental agencies and jurisdictions, including Seminole County, to aid in meeting the Goals, Objectives, and Policies of the Comprehensive Plan regarding land use planning and housing issues.

- Policy 1.2.1:** Identify and establish procedures by interlocal agreement with Seminole County for joint action regarding future joint planning areas, future annexations and compatible County and City land uses.
- Policy 1.2.2:** Seek to gain standing and representation on Seminole County Comprehensive Plan land use amendments which would prove inconsistent with the Future Land Use Element of the City's Comprehensive Plan.
- Policy 1.2.3:** Review the actions of other local governments as to the impact of such action on City LOS standards and mobility strategies. (Ord. 2010-18; 10-25-10)

- Policy 1.2.4:** ~~Continue Pursue collaborating opportunities to collaborate~~ on the regional Seminole Way initiative.
- Policy 1.2.5:** Continue to participate and coordinate joint planning and redevelopment activities in the US 17-92 Community Redevelopment Area (CRA) through intergovernmental coordination committees.
- Policy 1.2.6:** Coordinate with the School Board to provide planning for adequate sites and infrastructure for future public education facilities within the City, as described in the *2007 Interlocal Agreement for Public School Facility Planning and School Concurrency As Amended January 2008*.
- Policy 1.2.7:** Coordinate with the School Board during pre-development program planning and school site selection activities, to co-locate schools, to the extent possible, with other public facilities, such as parks, libraries, and community centers.
- Policy 1.2.8:** Share information with the School Board regarding population projections, projections of development and redevelopment for the coming year, infrastructure required to support educational facilities, and amendments to future land use plan elements, consistent with the requirements of the *2007 Interlocal Agreement for Public School Facility Planning and School Concurrency As Amended January 2008*.
- Policy 1.2.9:** Withhold development approvals for nonexempt properties having a residential component, until the School Board has reported either that school capacity is available or that mitigation has been reached. (Cross Reference: See Public School Facility Element, Policy 1.2.1 and Capital Improvements Element, Policy 1.7.6)

**Objective 1.3: Transportation Coordination.** The City shall continue to coordinate its transportation planning and mobility strategies with affected governmental agencies and jurisdictions. (Ord. 2010-18; 10-25-10)

- Policy 1.3.1:** Continue to coordinate with Florida Department of Transportation (FDOT) regarding issues associated with S.R. 434 including:
- A sufficient reduction in speed limit, as well as the potential for arterial reclassification, on S.R. 434 in the Town Center to better reflect the pedestrian-friendly environment being created in the Town Center. (Cross Reference: See Multimodal Transportation Element, Policy ~~1.1.8~~1.1.12 and 1.9.8)
  - The potential for implementation of a policy constraint for S.R. 434 between U.S. 17-92 and Vistawilla to ensure that the highway will not be considered for widening. (Cross Reference: See Multimodal Transportation Element, Policy ~~1.1.8~~1.1.12 and 1.9.9)



- Pursue widening of S.R. 434 to 4-lanes east of S.R. 417 within the Greenway Interchange District. (Cross Reference: See Multimodal Transportation Element, Policy 1.2.1~~54~~)
- Use of enhancement funding for streetscape and multimodal opportunities where appropriate.

**Policy 1.3.2:** Continue to actively participate in the METROPLAN ORLANDO Transportation Improvement Program (TIP) by submitting major projects for their inclusion in the program on an annual basis. (Ord. 2010-18; 10-25-10)

**Policy 1.3.3:** Remain involved in regional transportation planning through continued participation in the METROPLAN ORLANDO Transportation Technical Committee, and through continued citizen participation on the METROPLAN ORLANDO Citizen Advisory Council.

**Policy 1.3.4:** Coordinate with METROPLAN ORLANDO to implement partnerships for Transportation Regional Incentive Program (TRIP) projects beneficial to the City.

**Policy 1.3.5:** Coordinate with the Department of Environmental Protection (DEP) Office of Greenways and Trails, METROPLAN ORLANDO, FDOT, Seminole County, and other agencies to study and implement options for the coordinated provision of a pedestrian and bicycle trail network.

**Policy 1.3.6:** Continue to coordinate in the ongoing development, monitoring and implementation of mobility strategies with Seminole County and the cities within Seminole County, to ensure the availability of multiple modes of transportation within the City. (Ord. 2010-18; 10-25-10)

**Policy 1.3.7:** Promote the development of a bus rapid transit (BRT) line or light rail along S.R. 417 (Seminole Way) through interagency coordination with METROPLAN ORLANDO, Seminole County, LYNX, and the Florida Turnpike Enterprise to provide convenient, regional access to the City's Greenway Interchange District. (Cross Reference: See Future Land Use Element, Policy 3.1.3) (Ord. 2010-18; 10-25-10)

**Policy 1.3.8:** Work with the School Board to maximize efficient use of existing and planned roads to avoid sprawl development, during participation in future school site selection as identified in the *2007 Interlocal Agreement for Public School Facility Planning and School Concurrency As Amended January 2008*. (Cross Reference: See Public School Facilities Element, Policy 1.7.1) (previously Policy 1.3.7; Ord. 2010-18; 10-25-10)

**Objective 1.4: Infrastructure Coordination.** The City shall coordinate the planning and provision of infrastructure and services with affected governmental agencies and jurisdictions, including the Seminole County School Board.

- Policy 1.4.1:** Continue coordination efforts with Seminole County to ensure that the County is able to provide adequate solid waste facilities to meet the City's needs.
- Policy 1.4.2:** Coordinate with the Seminole County Health Department to ensure that where central sewer service is available, no new septic system permits shall be approved for any new development or any existing systems which have been determined to be inoperable or detrimental to the health, safety and welfare of the general public.
- Policy 1.4.3:** Coordinate the City's drainage program with Seminole County through an interlocal agreement which, when necessary, to resolve conflicts and ensure cooperation on the following issues:
- Initiating conflict resolution procedures to resolve inconsistencies between the City's LOS standards for drainage and the County's adopted LOS standards, when necessary.
  - Providing a method of fiscal responsibility for drainage systems which affect and serve primarily City residents, but which are under the jurisdiction of Seminole County.
  - Providing a method of prioritization of needed improvements on those drainage systems which affect and serve primarily City residents, but which are under the jurisdiction of Seminole County or the FDOT.
  - Determining jurisdictional authority for drainage systems which are "half in, half out" of the City limits.
- Policy 1.4.4:** Coordinate with the SJRWMD to ensure implementation of the ~~District Water Supply Plan 2015~~ Central Florida Water Initiative RWSP 2005 and its subsequent updates. (Cross Reference: See Conservation Element, Policy 1.2.9)
- Policy 1.4.5:** Work with the SJRWMD when alternative sources of providing potable water need to be evaluated.
- Policy 1.4.6:** Continue to pursue and assess the feasibility of interconnecting water supply facilities with other jurisdictions and seek to partner with adjacent cities in the development of the Lake Jesup Reclaimed Water Augmentation Facility.
- Policy 1.4.7:** Review the actions of other local governments as applicable, for their impact on City LOS standards. (Ord. 2010-18; 10-25-10)
-

**Policy 1.4.8:** Determine jointly with the School Board the need for and timing of on-site and off-site improvements necessary to support proposed new or remodeled schools.

**Policy 1.4.9:** Seek to maximize efficient use of existing infrastructure and avoid sprawl development, by identifying future school sites that take advantage of existing potable water, sanitary sewer and drainage systems. (Cross Reference: See Public School Facilities Element, Policy 1.7.1)

**Objective 1.5: Conservation Coordination.** The City shall coordinate with affected governmental agencies and jurisdictions, including the Seminole County School Board, to aid in meeting the Goals, Objectives, and Policies of the Comprehensive Plan regarding conservation planning. (Ord. 2007-22; 01-14-2008)

**Policy 1.5.1:** Continue coordination with federal, state, regional, and private environmental agencies to ensure adequate technical support for all environmental issues in which the City requires technical expertise.

**Policy 1.5.2:** Coordinate with appropriate federal, state, regional, and private environmental agencies and organizations to encourage the preservation of biological diversity and greenspace in the area including completing an area-wide evaluation to identify environmentally significant pieces of land to prioritize for protection, as well as identification of funding sources and partnership opportunities. (Cross Reference: See Conservation Element , Objective 1.8Z) Coordinate with the SJRWMD to designate priority open space areas for acquisition under the District's five-year land acquisition program.

**Policy 1.5.3:** Continue to participate and support programs and projects of State, Regional, and County agencies which seek to preserve environmentally sensitive lands, promote usable open space for all citizens, preserve habitats for listed wildlife species, protect groundwater and potable water supplies, and surface water quality, including participation in and support for programs such as the SWIM Program and wellfield protection programs sponsored by the SJRWMD.

**Objective 1.6: Parks and Recreation Coordination.** The City shall coordinate with affected governmental agencies and jurisdictions, including the Seminole County School Board, to aid in meeting the Goals, Objectives, and Policies of the Comprehensive Plan regarding parks and recreation planning.

**Policy 1.6.1:** Coordinate with Seminole County to recommend the provision of adequate land use acreage on the County's Future Land Use Map for park and recreational facilities within or in proximity to the City.

**Policy 1.6.2:** Continue to obtain and maintain interlocal agreements with the Seminole County School Board and Seminole County for the provision and maintenance of shared recreational facilities within the City.

**Policy 1.6.3:** Encourage the co-location of new school sites with City park and recreation facilities, to the extent feasible.

## **B. INTRODUCTION**

The *Local Government Comprehensive Planning Act* requires local comprehensive plans to be consistent with the goals of the state and regional policy plans. Local governments need to provide for this consistency in the goals, objectives, and policies of their comprehensive plans. The City's interpretation of the legislative intent of the consistency requirement is to provide for all comprehensive plans, adopted locally, to coordinate into a statewide framework for "growth management." One tool that the Act mandated to meet this legislative intent was for local comprehensive plans to adopt an Intergovernmental Coordination Element.

In order to provide for this consistency, coordination among state, regional, and local governments and agencies is essential. This coordination provides not only the method for the plans to be consistent, but also allows for more efficient delivery of services to the City residents. Mechanisms to meet this consistency requirement include, but are not limited to:

- Intergovernmental agreements;
- Joint planning and service agreements;
- Special legislation;
- Joint meetings, public hearings; and,
- Work groups or governmental programs designed to further intergovernmental coordination.

In addition, this Element can act as a catalyst for the smooth operation of the rest of the plan elements. By defining and creating tests of consistency within this Element, deficiencies within and among elements can be identified for the purpose of correcting them.

This Element can also be used as a mechanism to provide direction to the City for future implementation of federal, state, and regional programs, grants and assistance. Numerous government programs exist which can be used by the City in the implementation of the City's Comprehensive Plan. In addition, these programs can be used to meet the growing demands of the population growth on the City's services and public infrastructure.

## **C. INVENTORY OF EXISTING INTERGOVERNMENTAL COORDINATION MECHANISMS**

### **1. Local**

The City has used intergovernmental cooperation to further its coordination efforts with the following local agencies:

a. Seminole County School Board (School Board)

Historically, Chapter 163 Florida Statutes (F.S.), the law governing local comprehensive planning, did not include school facility planning. Seminole County, the School Board, and the cities initiated major efforts toward achieving coordination of land use and school facility planning with the adoption of an Interlocal Agreement in 1997. The Agreement created a framework for notification of proposed land use actions and a staff working committee called the Planning Technical Advisory Committee (PTAC). By 1999, in accordance with amendments to State Law, the County and cities had revised the Land Use Elements of their comprehensive plans to specify which land use designations allowed public schools as possible uses, and further refined processes to notify the School District and request comments on potential land development.

Seminole County and the cities within the County recognize the benefits of providing adequate public school facilities to their citizens and students in a timely manner. Because of the importance of the school system to the future of Seminole County, coordinated school planning among the County, the School Board and the seven cities continues to be understood as critical to ensure that public school capacity needs are met.

To further the goal of coordination, the School Board, the Seminole County Board of County Commissioners and governing bodies of seven cities adopted the *2007 Interlocal Agreement for Public School Facility Planning and School Concurrency As Amended January 2008 (2007 ILA)* that addressed coordination of public school facility and comprehensive land use planning. The County and cities also each adopted a Public School Facilities Element (PSFE) into their respective comprehensive plans. The PSFEs are compatible, establish countywide Levels of Service (LOS), and identify procedures for the district-wide school concurrency management process.

The process for developing both the *2007 ILA* and the PSFEs involved the PTAC, which included staff representing each of the signatories. During 2006 and 2007, the PTAC developed recommendations for coordination of land use and school facilities planning as the basis for the *2007 ILA*. The PTAC also reviewed drafts of a model PSFE for use by all involved. As directed by the *2007 ILA*, PTAC will meet a minimum of twice annually to discuss population and student projections, development trends, school needs, co-location and joint use opportunities, infrastructure improvements needed to support schools and safe student access, the School Board Five-Year Capital Improvement Plan and school concurrency processes. The shared use and co-location opportunities identified in the *2007 ILA* include park and recreational facilities, libraries, community centers, auditoriums, performing art centers, stadiums, learning centers, museums and governmental facilities.

In addition to the PTAC, the *2007 ILA* created the Public School Facilities Planning Committee (PSFPC), which will review the recommendations of PTAC and present recommendations to the School Board. This committee will serve as a standing committee to review the School Board Capital Improvement Plan, and will meet

jointly with the School Board annually. The membership of this committee will include elected officials or their designees, and will further the process of ensuring coordination of land use and school facility planning. Amendments to Section 163.3180, Florida Statutes (F.S.) enacted by the 2005 Florida Legislature mandated a comprehensive focus on school planning and required local governments and school boards to adopt district-wide school concurrency systems. School concurrency ensures coordination between local governments and school boards in planning and permitting developments that affect school capacity and utilization rates.

b. Seminole County

The City and Seminole County have several existing interlocal mechanisms to provide for efficient delivery of services to the citizens of the City and County. These mechanisms are:

- The Intergovernmental Planning Coordination Agreement of 1997 provides for City representation on the PTAC and for notification of land use changes adjacent to County and/or City boundaries, including other municipalities within Seminole County. The intent of the agreement is to provide for City input into the standards for development and land use changes that will impact City services, land use, and quality of life.
- 911 Emergency System provides for an interlocal agreement with the City to participate in the County 911 emergency system. This resolution also provides for the County to assign addresses for a consistent addressing system within the City and County.
- Agreement for the distribution of local option gas tax revenues.
- Seminole County Service-Annexation Interlocal Agreement of 1987- An interlocal agreement (1987) with Seminole County for the provision of essential governmental services by the City in enclave areas.
- An interlocal agreement for the provision of reciprocal emergency service responses.
- An interlocal agreement for the consolidation of the Winter Springs and Seminole County Fire Departments under the authority of Seminole County.
- An interlocal agreement for the collection and distribution of transportation impact fees and other transportation related issues.
- Community Development Block Grants (CDBG). Pursuant to the United States Department of Housing and Urban Development (HUD) application, the County shall undertake certain activities to develop a viable community, including an improved quality of life, principally for persons of low and moderate income. The City shall provide professional construction administration services for infrastructure improvements within the City to benefit ~~low and moderate income~~ low- and moderate-income residents.

- An agreement to participate in the U.S. 17-92 Community Redevelopment Agency (17-92 CRA). The 17-92 CRA establishes a tax increment finance district to fund redevelopment projects along the County's major north/south arterial. Portions of the arterial and taxable properties are within the City limits.
- An interlocal agreement for the regional coordination of water supply planning between the local governments within Seminole County.

c. Other Local Agencies

Several agencies exist in Seminole County that provide services and support to the citizens of the City. These agencies are:

- Economic Development Council (EDC) - The EDC is a nonprofit organization that was created to enhance, support, and promote economic development within Central Florida and Seminole County.
- Tourist Development Council (TDC) - The TDC acts to promote Seminole County as a tourist destination. The Council is funded by a five percent (5%) "tourist" tax on hotel/motel rooms in the County. This amount was recently increased. Two percent (2%) of these monies has been allocated for the development of Jetta Point County Park. No monies are received from local governments. The City is able to receive funding from this Council to provide for tourist related activities and infrastructure which increase hotel/motel usage in Seminole County. Funding requests are approved by the Seminole County Board of Commissioners.
- LYNX, the Central Florida Regional Transportation Authority's mass transit bus service, operates two routes adjacent to the City. These include a route with service along the U.S. 17-92 corridor and a route serving Oviedo Marketplace. There is no interlocal service agreement with this agency and the City does not currently contribute to LYNX bus service; there is an interlocal agreement between LYNX and Seminole County addressing fixed route bus and ADA paratransit service within the County. A new east-west route connecting from Oviedo Marketplace to northwest Orlando following S.R. 434 through the City is scheduled to begin as a demonstration project in 2009.
- The Department of Children and Families provides a number of services, including the licensing of group homes, child care, foster care services, and mental health and substance abuse counseling and services and the Florida Agency for Persons with Disabilities also provides licensing for group homes for handicapped persons.
- The Seminole County Health Department regulates and monitors the following: on-site sewage treatment and disposal systems, public swimming pools, drinking water, institutional food service, body piercing, biomedical waste, tanning, group care facilities, mobile home and recreational vehicle



parks, sanitary nuisances, restaurant sanitation, and arbovirus surveillance (sentinel chickens). The Health Department also works with the Center for Disease Control through its public health programs.

- The Seminole County Animal Services addresses stray and nuisance animal complaints within the City as well as in unincorporated Seminole County.
- The Seminole County Cooperative Extension Service provides family and consumer science, home horticulture, master gardener, and commercial agriculture assistance and services. They work closely with the University of Florida's IFAS extension.
- The Seminole County Soil and Water Conservation District is involved in a number of environmental endeavors, including establishment of a fertilizer-reuse outreach campaign to reduce pollutant loading into surface waters in conjunction with the FDEP.

## 2. Regional

On a regional basis, the City continues to participate in numerous committees sponsored by the East Central Florida Regional Planning Council (ECFRPC). This participation is noted in the inventory section of this Element. This representation has growing importance in the future growth and coordination of the City in regional issues. As the Orlando Urban Area continues to expand, there is stronger influence from the resulting growth-related pressures on the City. Regional growth will have a definite impact on the City's growth and its infrastructure and delivery of municipal services and will need to be addressed in the City's Comprehensive Plan.

Additionally, the City benefits from the regional resources provided by the St. John's River Water Management District. The mechanisms for coordination and input regarding these regional issues are as follows:

### a. East Central Florida Regional Planning Council (ECFRPC)

The ECFRPC is the regional planning agency responsible for the implementation of powers and duties, pursuant to Chapter 186, F.S., for Seminole County and the City. The ECFRPC, located in ~~Maitland~~ downtown Orlando, Florida, also has regional planning jurisdiction in the Counties of Sumter, Marion, Volusia, Orange, Lake, Osceola and Brevard.

The ECFRPC is the agency responsible for the development and implementation of the Regional Policy Plan. The ECFRPC has the responsibility, pursuant to Section 163.3184, F.S., to review local comprehensive plan amendments related to their relationship and effect on the Regional Policy Plan. As such, the ECFRPC may submit recommendations to the State requesting modifications.

~~Pursuant to Section 380.06 F.S., the ECFRPC also has the authority to regulate Developments of Regional Impact (DRI). DRI are developments that have a substantial effect on the health, safety, welfare, and quality of life of citizens in more than one county. The ECFRPC has the authority to ensure that these~~

~~developments are consistent with accepted LOS standards and the Regional Policy Plan, and the ECFRPC's recommendations are incorporated in any development orders for the DRI.~~

~~The Mayor currently serves as a member of the ECFRPC on behalf of the Seminole County League of Cities.~~ The purpose of the membership is to provide policy direction and manage regional policy issues to fulfill the ECFRPC's powers and duties.

b. METROPLAN ORLANDO

METROPLAN ORLANDO is the metropolitan planning organization for Orange, Osceola and Seminole Counties – the Orlando Urban Area. METROPLAN ORLANDO provides the forum for local elected officials and transportation experts to work together to improve mobility for Central Florida residents, businesses and visitors. METROPLAN ORLANDO produces a variety of plans and programs designed to guide the transportation planning process in Central Florida including a ~~Long-Range~~Long-Range *Transportation Plan* and the *Five-Year Transportation Improvement Program (TIP)*, as well as bicycle and pedestrian plans for the region.

The City is represented in the activities of METROPLAN ORLANDO through participation in two committees, as follows:

- The Mayor or his designee serves as a member of the METROPLAN ORLANDO Municipal Advisory Committee. The purpose of the committee is to provide a forum for incorporating the views of the mayors of the cities and towns that do not have representatives on the Board into the transportation policy development and decision-making process. Due to the limited number of seats on the METROPLAN ORLANDO Board, only the most populated cities in the ~~three-county~~three-county area are represented on the Board.
- One City staff member serves on the METROPLAN ORLANDO Transportation Technical Committee. This committee reviews regional transportation plans and provides policy direction for transportation issues in Seminole, Orange, and Osceola Counties. Using input from the Transportation Technical Committee, an urban area transportation study is developed, and subsequently the TIP is developed and adopted.

c. St. Johns River Water Management District (SJRWMD)

Created in 1972, the SJRWMD is responsible for flood control and water conservation in the St. Johns River region. The City is within the jurisdiction of the SJRWMD.

This authority has regulatory control over all water--based resources within its jurisdiction. The SJRWMD has the following responsibilities:

Permitting of consumptive use of water;

Regulation of wells;  
Management and storage of surface water; and  
Water storage.

All new developments and utility services may be required to obtain a permit from the SJRWMD, prior to the issuance of a development order.

Generally, a development is exempt from formal drainage review and permitting if the site meets the following criteria:

Less than two (2) acres of impervious area, and;  
Ten (10) acres or less of total area.

The SJRWMD has a local office in Altamonte Springs that reviews development plans in Seminole County and may require plan modifications, prior to granting approval. The Public Works Department is the principal liaison in these reviews. The SJRWMD is also a primary reviewer of local comprehensive plan amendments and as such, conveys their comments to the Community Development Department-Planning Division.

The City coordinates SJRWMD regarding a variety of water resources-related issues, including wetlands permitting, stormwater management, Lake Jesup restoration, creation and maintenance of conservation areas, and regional projects. One regional stormwater project in the City is the Solary Canal project, located at the northeast corner of the City on the east side of DeLeon St. Solary Canal is a stormwater treatment facility that will consist of a wet detention pond and wetland treatment area. The project will intercept and treat stormwater from "Sweetwater Creek," which collects stormwater runoff primarily from properties within the City of Oviedo.

#### *Water Supply Planning and Coordination*

Subsection 163.3191(2)(L), F.S. requires coordination between water supply planning and future land use planning in order to ensure an adequate supply of water to support future development. In 2004, the City entered into an interlocal agreement with Seminole County and the other cities within the County to develop a county-wide water supply plan (County Plan). The City's Water Supply Work Plan must be coordinated with the County Plan, as well as with the ~~SJRWMD District Water Supply 2005 and 2006 Addendum~~ 2015 CFWI RWSP and the ECFRPC Strategic Regional Policy Plan ~~1998~~ 2013. The County Plan was completed in 2007; the City's Water Supply Work Plan was also updated in 2007. The City's Water Supply Work Plan will be updated by 2020 to ensure consistency with the new plans.

These plans identified a number of projects including a recommendation to proceed with the design of the Lake Jesup Reclaimed Water Augmentation Project and to negotiate with adjacent cities to partner in the project. Information on the status of the City's design and development plans for the facility are presented in

the Infrastructure Element. In addition, the City will participate in the joint planning process for the St. John's River Regional Surface Water Supply Plant at S.R. 46.

### 3. State

State agencies such as the Florida Fish and Wildlife Conservation Commission (FWCC), and the Department of Environmental Protection (DEP) are instrumental in helping the City meet the goals, objectives and policies of the City's Conservation, Recreation and Open Space, Sanitary Sewer, Solid Waste, Drainage, Potable Water, and Natural Groundwater Aquifer Recharge Elements. The Department of Economic Opportunity Community Affairs (DCA) is the agency charged with the administration of the Comprehensive Plan and the determination of compliance of local plans with Chapter 163, Florida Statutes (F.S.) ~~and Rule 9J-5, Florida Administrative Code (F.A.C.)~~. ~~In addition, the DCA and the Department of Children and Families (DCF) can aid in the implementation of the City's Housing Element.~~ The DEP will monitor and approve all policies respective to the Sanitary Sewer, Solid Waste, Drainage, Potable Water, and Natural Groundwater Aquifer Recharge Element. The ~~DCA-DEO~~ provides direction regarding the Future Land Use Element and the ability of the City's Comprehensive Plan to provide for an efficient and effective economic base for State and local growth. The effectiveness of the City's Transportation Element will be affected greatly by the actions and policies of the Florida Department of Transportation (FDOT).

The actions of the state legislature will also impact the effectiveness of the City's Comprehensive Plan; specifically, future funding needs of the State of Florida. Coordination and cooperation between the state and local governments is necessary to ensure public policy efficiency and to address the economic implications of public policy funding issues. Funding is extremely critical for smaller, rapidly growing communities especially in the current economic environment. In order for the City to effectively meet the requirements of Chapter 163, and other state-mandated policies, future state funding resources will continue to be critical in providing a safe and livable community.

a. Department of ~~Community Affairs (DCA)~~Economic Opportunity

~~DCA-DEO~~ is the primary state agency responsible for review of local comprehensive plans and land use map amendments. The Community Development Department - Planning Division is the principal liaison with ~~DCA-DEO~~ to ensure local compliance with the comprehensive planning statute (Chapter 163, F.S.) ~~and administrative rule (9J-5, F.A.C.)~~.

~~DCA-DEO~~ also provides technical assistance and administers grant programs available to local governments. The agency provides assistance in the areas of housing, community development, resource planning and management, community services, land and water management, public safety, while promoting economic growth and prosperity by supporting talent and business development, promoting Florida's innovation, probusiness climate and opportunity, and promoting great quality of life and quality of places by providing safe, health and resilient communities. ~~and emergency management preparedness and post-disaster~~

~~recovery. In addition, DCA is the state agency responsible for coordination and review of Developments of Regional Impact.~~

~~DCA administers the state's handicap accessibility regulations, set forth in Chapter 11 of the Florida Building Code. The Florida handicap accessibility requirements are typically more stringent than the Federal Americans with Disabilities Act (ADA) requirements and super-cedes them in Florida.~~

~~DCA also administers FEMA programs: when the President declares an emergency or a major disaster, federal assistance is authorized to the state, administered by DCA with its Division of Emergency Management (DEM) as the grantee. All applicants applying for federal aid are sub-grantees. The DEM has the authority under the Federal declaration to act on behalf of all sub-grantees under the Federal program.~~

~~DCA has signed agreements with most jurisdictions and the Building Officials Association of Florida (BOAF) regarding mutual aid in the event of a disaster or emergency for damage assessment and habitability inspections. This is coordinated with county emergency management.~~

~~DCA administers energy efficiency provisions through the Florida Building Code, Chapter 13.~~

b. Florida Department of Transportation (FDOT)

FDOT is the primary State agency responsible for Florida's transportation system. FDOT has authority over, and is responsible for, the following state highways and roads in the City:

- S.R. 419;
- S.R. 434; and
- U.S. 17-92.

These roadways are displayed in the Transportation Element.

FDOT has regulatory authority over the use of land within rights-of-way and surface water discharge into highway drainage systems. As such, FDOT regulates curb cuts, traffic signalization, tree and other landscape plantings and drainage flow on Florida's highway system. FDOT is also responsible for determining the functional classification of major roads within the City and the surrounding area. The office responsible for local coordination is located in DeLand. FDOT is also a primary reviewer of local comprehensive plan amendments for their impacts to transportation, and as such, conveys their comments to the Community Development Department - Planning Division.

Florida's Turnpike operates as a separate business unit of FDOT. Florida's Turnpike is responsible for all operations on every FDOT-owned and operated toll road and bridge. This represents about 600 miles of roadway and 80 percent of all toll facilities in Florida. Florida's Turnpike operates the northern 17 miles of S.R. 417 as the "Seminole Way," beginning at the Seminole County line and

extending north to its terminus at Interstate 4 in Sanford. Two segments of the Seminole Expressway are located in the City, with one segment north of the Winter Springs Blvd. overpass and another segment from the S.R 434 interchange to Lake Jesup. The Orlando-Orange County Expressway Authority (OOCEA) operates the middle section of Toll 417, from Milepost 6 in Orange County to Milepost 37.5 at the Seminole County line. This section is known as the Central Florida GreeneWay. The Turnpike also operates the southern end of Toll 417, from Milepost 1 at Interstate 4 to Milepost 6 in Orange County. This section of Toll 417 is known as the Southern Connector Extension, but it also referred to as the southern end of the Central Florida GreeneWay.

c. Department of Environmental Protection (FDEP)

FDEP is responsible for preserving the quality of Florida's land, water, and air resources. FDEP has regulatory control of industrial waste, air pollution emissions, hazardous waste, potable water usage, solid waste, sewage disposal, dredge and fill activities (including wetland encroachment issues on individually owned residential lots), and environmentally sensitive areas.

The Public Works Department is the principal liaison office with FDEP. In addition, FDEP has regulatory and monitoring authority over new sewage disposal line extensions that will impact the City's sewage disposal system.

FDEP is also responsible for the monitoring of any construction or dredge and fill activity along Lake Jesup and any channel or canal must receive permits from FDEP prior to commencement of such activity. In addition to the responsibilities listed above, FDEP duties include management of state-owned lands and aquatic preserves. As such, FDEP has regulatory authority of submerged bottomlands, including grass beds and aquatic life, and jurisdictional wetlands. FDEP reviews all dredge and fill permits to ensure that construction activity will not adversely impact Florida's aquatic resources. The local office of FDEP is located in Orlando.

d. Florida Fish and Wildlife Conservation Commission (FFWCC)

FFWCC is charged with the responsibility of regulating hunting, fishing, and protecting listed (i.e. endangered, threatened, and species of special concern) wildlife species. It has no unilateral control over any areas surrounding the City, but rather coordinates with FDEP and SJRWMD and other regulatory agencies to review projects that would adversely impact fish and wildlife habitats. However, FFWCC has very little enforcement power except on issues dealing directly with game and listed wildlife species.

e. Florida Department of Agriculture and Consumer Services (FDACS)

FDACS is a resource for publications and standards related to tree and plant care, and prohibited plant species. FDACS administers and oversees numerous programs and grants including Tree City USA and the Urban and Community Forestry Grant program. The Urban Beautification Division of the Community

Development Department is the entity responsible for coordination with this agency.

f. Department of State, Division of Historical Resources (DHR)

DHR provides assistance to local governments in the field of historical preservation and maintains a database of historic structures, historic sites and archeological information. The City's coordination efforts will continue to be through the Tallahassee office of DHR, with the Community Development Department being the City's office with primary responsibility for coordination. DHR is also a primary reviewer of local comprehensive plan amendments for their impact on historical and archaeological resources, and as such, conveys their comments to the Community Development Department - Planning Division.

#### 4. Federal

~~Although federal intergovernmental coordination is not required to meet the requirements of Rule 9J-5, F.A.C.,~~ The City must address federal regulations and programs to ensure the most effective implementation of comprehensive plan objectives and policies.

For example, the need to analyze and review legal constitutional issues regarding property rights continues to be important during the review and development of the goals, objectives and policies of the Future Land Use and Capital Improvement Elements, and in the creation and administration of land development regulations and associated ordinances and codes. Environmental regulations can affect the implementation of the Sanitary Sewer, Solid Waste, Drainage, Potable Water, and Natural Groundwater Aquifer Recharge elements and costs of system expansions.

In addition, numerous federal programs are available to possibly aid the City in implementing the Comprehensive Plan, including, but not limited to programs that address low-income housing, improvements in waste disposal and environmental protection. A majority of these programs are administered by the State, but an understanding of their purpose is important to their implementation and inclusion in the Comprehensive Plan.

a. U.S. Environmental Protection Agency (EPA)

The U.S. Environmental Protection Agency (EPA) developed the federal National Pollutant Discharge Elimination System (NPDES) stormwater permitting program in two phases. Phase I, promulgated in 1990, addresses municipal separate storm sewer systems (MS4s) located in incorporated places and counties with populations of 100,000 or more, such as Seminole County. Phase II, promulgated in 1999, addresses additional sources, including MS4s not regulated under Phase I, and small construction activity disturbing between 1 and 5 acres.

In October 2000, EPA authorized the FDEP to implement the NPDES stormwater permitting program in the State of Florida (in all areas except Indian Country lands). FDEP's authority to administer the NPDES program is set forth in Section 403.0885, Florida Statutes (F.S.). The NPDES stormwater program regulates point source discharges of stormwater into surface waters of the State of Florida from



certain municipal, industrial and construction activities. As the NPDES stormwater permitting authority, FDEP is responsible for promulgating rules and issuing permits, managing and reviewing permit applications, and performing compliance and enforcement activities.

In Seminole County, the County and the seven incorporated cities including the City are listed as co-permittees under one NPDES permit. The City coordinates closely with Seminole County and the other cities regarding the implementation of the NPDES permit. The Utility Department is the office responsible for coordination with the EPA.

b. U.S. Department of Agriculture (USDA)

The Public Works Department is the primary liaison with the USDA. The USDA Natural Resources Conservation Service (NRCS) assists in relieving hazards created by natural disasters that cause a sudden impairment of a watershed. Aid for the installation of emergency watershed protection measures to relieve hazards and damages to the watershed were provided to the City after the 2004 hurricanes and 2007 tornadoes.

c. U.S. Army Corps of Engineers (ACOE)

The City coordinates with the ACOE regarding the maintenance and use of Lake Jesup. The ACOE has a local office in Jacksonville. The City Manager's office will continue to be the liaison to the ACOE.

d. U.S. Housing and Urban Development (HUD)

The City coordinates with HUD and the Florida ~~DCA-DEO~~ on projects pertaining to the provision of housing to low and moderate-income residents and regularly receives Community Development Block Grants (CDBG) grant funds through interlocal agreements with Seminole County pursuant to HUD requirements.

e. U.S. Flood and Emergency Management Agency (FEMA)

The City coordinates with FEMA primarily in the areas of disaster assistance and floodplain management.

There are three categories of disaster assistance: Individual Assistance, Public Assistance, and Hazard Mitigation. The scope of disaster assistance available from FEMA depends on the nature and severity of the event. FEMA disaster assistance has historically been available after severe storm events including hurricanes and tropical storms.

The City participates in the National Flood Insurance Program (NFIP), administered by FEMA. The three components of the NFIP are: Flood Insurance, Floodplain Management, and Flood Hazard Mapping. The City participates in the NFIP by adopting and enforcing floodplain management ordinances to reduce future flood damage. The City administers its FEMA responsibilities through the Stormwater Manager's role in the floodplain map, the City Engineer's role in requiring

compensating storage for encroachment into the floodplain and prohibiting development in the floodway, and the Building Official requiring the finished floor of new buildings or additions to be at least 18 inches above the 100-year floodplain elevation, as well as emergency preparedness and response. Chapter 8 of the City Code addresses flood damage prevention and designates the City Manager as the City's Floodplain Administrator. His duties and responsibilities in that position relate to the City's involvement in emergency or disaster preparedness and response and the City's involvement in the National Flood Insurance Program.

In exchange, the NFIP makes federally backed flood insurance available to homeowners, renters, and business owners in these communities. In addition to providing flood insurance and reducing flood damages through floodplain management regulations, the NFIP identifies and maps the Nation's floodplains. Mapping flood hazards creates broad-based awareness of the flood hazards and provides the data needed for floodplain management programs and to actuarially rate new construction for flood insurance. In September 2007, FEMA issued new Flood Insurance Rate Maps. (The previous map update was in 1995.) Chapter 8 of the City Code has been amended to be consistent with the new maps.

Strict adherence to the National Flood Insurance Program criteria is important to flood insurance rates within a jurisdiction as well as protection of life and property.

All new development including building permits are reviewed for compliance with the City's floodplain management ordinances.

## **5. Utilities**

### **a. Electric**

The City has an interlocal agreement with Florida Power Corporation (aka Progress Energy) to operate as the City's electric utility. Progress Energy is the installer of all streetlights. The Community Development Department- Urban Beautification Division works closely with Progress Energy in the implementation of these upgrades. The Utility Department is the liaison with Progress Energy for burying utility lines.

A Florida Power and Light (FP&L) transmission line easement cuts across the entire City. The City has an interlocal agreement for installation of reclaimed water lines within the easement. Additional multi-use options for the easement, such as a trail corridor, will require a cooperative effort between both parties.

### **b. Sanitary Sewer, Potable Water and Reclaimed Water**

The City operates its own utility for the purpose of the delivery of potable water, the collection of sanitary sewer, and the operation of a water reuse program. Residential, commercial, and industrial users are served by both systems. The Utility Department operates and maintains both systems. Maps of the sanitary

sewer service area, potable water service area and reclaimed water service areas are included in the corresponding Infrastructure Sub-elements.

c. Telephone

Land line telephone service is provided under franchise agreements with Sprint-United Telephone-Florida and Bellsouth.

Numerous cellular providers service the City. A study completed in April 2006, identified the Tusawilla area as having inadequate service. As a result, the City amended its ordinance and allowed a new stealth 150' unipole tower to be constructed on the Tusawilla Golf and Country Club property. The new tower is designed to handle seven carriers.

d. Cable Television

Previously, the City maintained a franchise agreement with Bright House Networks for provision of cable television service. This agreement was to expire on September 11, 2015; ~~h~~However, the recent adoption of the Consumer Choice Act (Chapter 610, Florida Statutes) has allowed cable and video providers to opt out of their local government agreements. Bright House selected this option, thereby nullifying their agreement with Winter Springs.

e. Solid Waste Collection

The City provides solid waste collection services for both residential and commercial users through Waste Pro, a private hauler. The current franchise agreement with Waste Pro is for a ~~five-year~~five-year period and expires on February 28, 2011. Seminole County operates a landfill and transfer station. To meet compliance with the State resource recovery statute, the City has also enacted policies for the collection and reclamation of aluminum, glass, plastic, and newspaper products. The General Services Administrator is responsible for monitoring the City's solid waste franchise and Seminole County is responsible for the operation of the landfill.

f. Gas Service

The Florida Public Utilities Company supplies residential, commercial, and industrial gas service within the City's corporate limits.

## D. ANALYSIS FOR IMPROVEMENTS TO INTERGOVERNMENTAL COORDINATION

### 1. Intergovernmental Mechanism Opportunities and Problem Areas

a. Local

In 2005, the Florida legislature, recognizing the need for improved coordination between local governments and school boards, mandated a comprehensive approach to school planning. As a result, a coordinated effort was undertaken by the local jurisdictions of Seminole County and the Seminole County School Board,

resulting in an updated interlocal agreement. The 2007 *ILA* includes procedures for coordinating land use planning, development approvals and school planning. Additionally, a Public School Facilities Element was added to each local government's comprehensive plan that is consistent with those adopted by the other local governments. These tools will enable better coordination of public school facility planning with land use planning and development approvals.

In January 2007, the City adopted Future Land Use Element, Policy 1.8.4 establishing an eastern annexation boundary for the City, at DeLeon Street. The intention of this policy was to protect the rural and environmentally sensitive Black Hammock area from future urbanization. Annexations by the City in this general area in the past had subsequently resulted in litigation and distrust for the City by both area residents, the City of Oviedo and Seminole County. By implementing an annexation boundary, the City gained an improved relationship, especially with Seminole County.

Now that the City can no longer sprawl eastward, it will be more dependent upon infill development and the annexation of enclaves to provide growth opportunities. The City has had an agreement with Seminole County since 1987 relating to the annexation of enclaves; however, this agreement primarily addresses the provisions of essential governmental services by the City to enclave areas. Both the City of Longwood and the City of Altamonte Springs each have had an interlocal agreement with Seminole County since the mid 1990's which allow the involuntary annexation of enclaves which are ten acres or less, when there is a change in the parcel's ownership. During 2008, the City Commission expressed interest in pursuing legal options available for eliminating enclaves, in furtherance of the public policy expressed under the annexation laws of Florida. As a result, a preliminary meeting was held between the City Manager and County Manager. The outcome of this meeting was an indication by the County that they would be amenable to having an agreement with the City that includes the same terms as the Longwood agreement, but likely would not support any variation to the terms of the Longwood agreement. Given that enclaves are a potential source of conflict, the City should continue its efforts to work with Seminole County to amend the 1987 agreement to allow for the involuntary annexation of enclaves that are less than 10 acres.

An area of concern for the City is the road capacity for S.R. 434, east of S.R. 417. The City has no jurisdiction over this segment of roadway and future development of the City's Greenway Interchange District (aka Seminole Way) will likely have difficulty meeting transportation concurrency. It will be important for the Seminole Way initiative to work with local jurisdictions and FDOT to address this obstacle.

Interlocal agreements can resolve many conflicts that may otherwise arise between the City and other local governments and should continue to be pursued to the extent practicable.

b. Regional

The City has become an active member in programs and committees administered through the ECFRPC by representation of both elected officials and staff. In 2007, the Central Florida Joint Policy Framework Committee created a regional growth compact consisting of six (6) regional growth principles. These include:

- Preserving open space, recreational areas, farmland, water resources and regionally significant natural areas;
- Providing a variety of transportation choices;
- Fostering distinct, attractive, and safe places to live;
- Encouraging a diverse, globally competitive economy;
- Creating a range of obtainable housing opportunities and choices; and
- Building communities with education, health care, and cultural amenities.

These principles grew out of a visioning process conducted during 2006 and 2007. The process involved approximately 20,000 central Florida residents who were asked to answer the question “How Shall We Grow?” through a series of community meetings, presentations and surveys.

The product of this process, *The Central Florida Regional Growth Vision* represents a shared vision of the preferred method for directing the growth of the seven (7) county region that includes the City, between 2007 and 2050. By 2050, the population of the region is expected to more than double from 3.5 million to 7.2 million residents, thus necessitating development of a guiding vision.

The ~~Mayor-City has been~~was an active participant in this process and ~~has served on~~the Myregion.org Board of Directors. ~~The Mayor and~~currently participates in the Congress of Regional Leaders to promote the Central Florida Regional Growth Vision. The City will continue its involvement in development and implementation of *The Central Florida Regional Growth Vision*.

In addition, the City will continue to actively participate in METROPLAN ORLANDO and will include appropriate local road projects in METROPLAN ORLANDO’s five-year transportation plan. As noted in the Introduction of this Element, rapid growth in the Orlando Urban Area continues to influence the City’s growth. This growing regional impact requires that the City exercise all of its options to ensure regional representation on policy decisions that will influence the growth of the City.

Locally the City coordinates with the St. Johns River Water Management District (SJRWMD) in their review of development permitting applications. This review by the SJRWMD generally takes six (6) weeks or longer depending upon the quality of the submittal and the proposed development’s impact to wetlands. The City relies on the SJRWMD to determine appropriate mitigation for impact to wetlands.

Coordination between the City and the SJRWMD on the creation and implementation of a wellfield protection ordinance is still needed. The SJRWMD

has invaluable resources and technical assistance that can help ensure the success of this necessary ordinance.

c. State

Existing intergovernmental coordination with State agencies has been improved significantly over the last five years as the City has added Staff with professional expertise and commitment to intergovernmental cooperation.

FDEP has been helpful in the review and permitting of City improvements to the City's wastewater treatment system. The City has adopted internal policies to match the accounting system used by FDEP for sewer allocations. Improved coordination with FDEP has provided for special public works projects to be completed on time and in compliance with FDEP standards.

While updating the Comprehensive Plan, the City has noted various infrastructure needs that will require continued coordination with State agencies. The City has made substantial progress in coordination with the FDOT through the City's participation in the METROPLAN ORLANDO's Transportation Improvement Program process, and the City's involvement in the public hearing process for the FDOT Improved Tentative Work Program.

It is important that the City continue its involvement in the formal procedures noted above, as well as improving its informal working relationship with the FDOT. Informal coordination includes Development of Regional Impact reviews and access management coordination. A continued working relationship with the FDOT will ensure timely consideration of needed state roadway improvements and improved traffic circulation within the city.

Coordination with other state agencies has been acceptable and further analysis is not required.

d. Federal

Coordination with federal agencies has been acceptable.

**2. Future Growth and Development and the Role of Intergovernmental Coordination**

In order to continue to avoid future conflicts between the City's Comprehensive Plan and the regional policy plan, the City will continue to utilize the regional policy plan and regional growth vision in evaluating the proposed growth and development when amending the City's Comprehensive Plan. If a conflict arises, the City will coordinate with the ECFRPC and the Comprehensive Regional Policy Plan Advisory Committee to alleviate the conflict. In addition, the City shall continue to participate in the preparation of the evaluation report for the East Central Florida Comprehensive Regional Policy Plan required pursuant to Section 186.511, Florida Statutes.

Additionally, the City shall continue to coordinate with local, state and federal agencies for grant opportunities and improvements.

**3. Areas of Critical State Concern**

There are no areas of critical state concern within the City's corporate boundaries at this time.

**Table VII - 1: Intergovernmental Coordination Contacts**

Name of Agency	Address	Phone	City Coordinating Office
<b>LOCAL:</b>			
Seminole County School Board	400 E. Lake Mary Blvd. Sanford, FL 32773	(407) 320-0000	Community Development, Public Works, and Parks & Recreation
Seminole County	1101 E. First St. Sanford, FL 32771	(407) 665-7219	Mayor, Community Development, Public Works, and Parks & Recreation
City of Oviedo	400 Alexandria Blvd. Oviedo, FL 32765	(407) 971-5555	Community Development and Public Works
City of Longwood	175 W. Warren Ave. Longwood, FL 32765	(407) 260-3440	Community Development and Public Works
City of Casselberry	95 Lake Triplet Dr. Casselberry, FL 32707	(407) 262-7700	Community Development and Public Works
<b>REGIONAL:</b>			
East Central Florida Regional Planning Council	<del>631 N. Wymore Rd.</del> <del>Maitland, FL 32751-455</del> <u>N. Garland Ave.,</u> <u>Orlando, FL 32801</u>	(407) <del>623-</del> <del>1075</del> <u>245-0300</u>	Community Development



St. Johns River Water Management District	<del>975 Keller Rd. Altamonte Springs, FL 32714</del> <del>601 S. Lake desnity Rd. STE 200, Maitland, FL 32751</del>	(407) 659-4800	Public Works / Utilities
LYNX	455 N. Garland Ave. Orlando, FL 32801	(407) 841-2279	Community Development and Public Works
METROPLAN ORLANDO	<del>315 E. Robinson St. Orlando, FL 32801</del> <del>250 S. Orange Ave. #200 Orlando, FL 32801</del>	(407) 4881480	Public Works
<b>STATE:</b>			
Department of <del>Community Affairs</del> <del>Economic Opportunity</del>	<del>2555 Shumard Oak Blvd. Tallahassee, FL 32399</del> <del>107 E. Madison St., Tallahassee, FL 32399</del>	(850) <del>488-8466</del> <del>204-2418</del>	Community Development
Florida Department of Transportation – District 5	719 S. Woodland Blvd. DeLand, FL 32720	(386) 943-5475	Public Works
Florida Department of Environmental Protection	3319 Maguire Blvd., Suite 232 Orlando, FL 32803	(407) 894-7555	Community Development and Public Works
Florida Fish & Wildlife Conservation Commission	Southwest Region 3900 Drane Field Rd. Lakeland, FL 32811-1299	(863) 648-3202	Community Development
<del>Department of Children &amp; Families</del>	<del>400 W. Robinson St. Orlando, FL 32801</del>	<del>(407) 245-0400</del>	<del>City Manager</del>
Florida State Division of Historical Resources	500 S. Bronough St. Tallahassee, FL 32399-0250	(850) 245-6300	Community Development
<b>FEDERAL:</b>			
Army Corps of Engineers	P.O. Box 4970 Jacksonville, FL 322232;	(904) 323-2255	Public Works
Environmental Protection Agency	Sam Nunn Atlanta Federal Center 61 Forsyth St. SW Atlanta, GA 30303-8960	(404) 562-9900	Public Works
Florida Department of Agriculture & Consumer Services	The Capitol Tallahassee, FL 32399-0800	(850)488-3022	Community Development
<b>UTILITIES:</b>			

Bright House Networks	85 N. Keller Rd # 551 Maitland, FL 32751	(407) 215-0000	Finance
Sprint-United Telephone-Florida	P.O. Box 3348 Greenwood, SC 29648	(800) 733-9045	Finance
Bell South	501 W. 9th St. Sanford, FL 32771	(407) 323-4720	Finance
Florida Public Utilities Company	450 S. U.S. 17-92, DeBary, FL 32713	(386) 668-2600	Finance
Progress Energy	P.O. Box 33199 St. Petersburg, FL 33733- 8199	(727) 824-6400	Finance and Community Development
Waste Pro	2101 W. S.R. 434 # 315 Longwood, FL 32779	(407) 869-8800	Finance and General Services

Source: Planning Communities, LLC, January 2009.

**Table VII - 2: Inventory of Existing Interlocal Agreements**

Agreement Between	Type of Agreement	Details of Agreement	Agreement Dates
<b>DRAINAGE</b>			
<del>Seminole County and the City</del>	<del>Letter of Understanding related to Florida Yards and Neighborhood Program (FYN)</del>	<del>Funds educational instruction through the FYN Program to address the serious problems of pollution, water shortages, and disappearing habitats by enlisting Floridians help in reducing stormwater runoff, conservation of water and improving home and landscape management practices.</del>	<del>Oct. 1, 2008 exp Sept. 30, 2013</del>
Seminole County and the municipalities of Altamonte Springs, Casselberry, Lake Mary, Longwood, Oviedo, Sanford, and Winter Springs	Interlocal Agreement related to Total Maximum Daily Load	Provides intergovernmental cooperation on stormwater TMDL related implementation activities by streamlining intergovernmental cooperation on regional TMDL issues, increasing the effectiveness in seeking and obtaining matching funds from outside sources, and allowing local governments to share knowledge and resources on TMDL issues by creating a TMDL Technical Coordination Group TCG.	July 6, 2007
Seminole County and the municipalities of Altamonte Springs, Casselberry, Lake Mary, Longwood, Oviedo, Sanford, and Winter Springs	Memorandum of Agreement for Mosquito Abatement	Implements a countywide mosquito control program focused on integrated pest management.	Oct. 29, 2006 <del>3-year program</del>
Seminole County and the municipalities of Altamonte Springs, Casselberry, Lake Mary, Longwood, Oviedo, Sanford, and Winter Springs	Interlocal Agreement for the Watershed Atlas, First Amendment	Provides joint funding for the watershed atlas.	Mar. 28, 2006
School Board, Seminole School Board Leasing Corp., and the City	Interlocal Agreement for Stormwater Project and Easement	City to design, permit, construct and maintain a modification of the existing stormwater pond on school board property. Preserves and protects the stormwater value of the property in perpetuity.	July 5, 2001

Agreement Between	Type of Agreement	Details of Agreement	Agreement Dates
Seminole County and the municipalities of Altamonte Springs, Casselberry, Lake Mary, Longwood, Oviedo, Sanford, and Winter Springs, and FDOT	Interlocal Agreement for Joint Control of Pollutants between Municipalities, Seminole County and FDOT within Seminole County	Sets forth general responsibilities in controlling the contribution of pollutants from one city, department, or county storm sewer system to another	July 11, 1996
<b>EDUCATION</b>			
School Board, Seminole County and the municipalities of Altamonte Springs, Casselberry, Lake Mary, Longwood, Oviedo, Sanford, and Winter Springs	2007 Interlocal Agreement for Public School Facility Planning and School Concurrency As Amended January 2008	Includes definitions and procedures to be followed in coordinating land use, public school facilities planning, and school concurrency.	Jan. 14, 2008 effective Jan. 1, 2008
School Board, Seminole County and the municipalities of Altamonte Springs, Casselberry, Lake Mary, Longwood, Oviedo, Sanford, and Winter Springs	2003 Interlocal Agreement for Public School Facility Planning	Establishes a formal coordination framework for joint meetings, coordination, and sharing of information regarding development impacts on school enrollment and collaborative planning and decision making related to coordination of land use and public school facility planning.	Apr. 15, 2003
School Board and the City	Grant of Easement	Provides School Board with the right to use the easement area without limitation for parking areas, driveways, and landscaping.	Jan. 16, 2001
School Board and the City	Educational System Impact Fee Interlocal Agreement	Authorizes the City to collect School Board imposed impact fees for schools for an administrative fee.	Aug. 1996 <del>self-renewing</del> <del>self-renewing</del> annually, Oct 1
<b>OTHER</b>			
School Board and the City	Interlocal Agreement for Fueling of city Vehicles and Equipment	Provides the City access to fueling facilities owned and maintained by School Board.	Jan. 1, 2007 to June 30, 2007 thereafter <del>self-renewing</del> <del>self-renewing</del> annually

Agreement Between	Type of Agreement	Details of Agreement	Agreement Dates
Seminole County and the City	Interlocal Agreement related to Business Tax Receipts, First Amendment	Transfers administrative responsibilities relative to collection and enforcement of County business tax receipts for businesses domiciled within the City.	Dec. 13, 2006
Seminole County and the City	Interlocal Agreement related to Occupational License Taxes	Transfers administrative responsibilities relative to collection and enforcement of County business tax receipts for businesses domiciled within the City.	Oct. 13, 2003
Seminole County and the municipalities of Altamonte Springs, Casselberry, Lake Mary, Oviedo, Sanford, and Winter Springs, and the School Board	Intergovernmental Planning Coordination Agreement of 1997	Establishes framework for coordination, communication and notification of proposed land use actions, to build cooperation between affected local governments and School Board and creates an opportunity and process to resolve potential disputes and to serve as an interim step until the County and cities adopt JPAs.	Feb. 22, 1999
Seminole County and the municipalities of Casselberry, Lake Mary, Sanford, Winter Springs, and the U.S. 17-92 CRA	Interlocal Agreement establishing the U.S. 17-92 Corridor Redevelopment Planning Agency	Establishes U.S. 17-92 Corridor Redevelopment Planning Agency (RPA); provides for City participation in the effort to redevelop U.S. 17-92 through the collection of tax increment financing and provides for participation in the decisions made by the Community Redevelopment Agency (CRA).	Oct. 21, 1998
Seminole County and the City	Interlocal Agreement and Agreement Relating to Design, Construction, and Maintenance of Wall Project	Sets appropriation of funds between the jurisdictions for construction of wall along Tuskawilla Road (Oak Forest Subdivision).	June 10, 1997
Seminole County and the City	Library System Impact Fees	Authorizes the City to collect County library system impact fees.	Oct. 4, 1996
Seminole County and the City	Interlocal Agreement for Utility Engineering Design	Authorizes the County to perform services in the City. City to pay County all costs for performance of services (Tusawilla Phase IV).	Mar. 14, 1996

Agreement Between	Type of Agreement	Details of Agreement	Agreement Dates
Seminole County and the municipalities of Altamonte Springs, Casselberry, Lake Mary, Longwood, Oviedo, Sanford, and Winter Springs, and the School Board	Interlocal Agreement on Mediation and Intergovernmental Coordination	Provides a mechanism to resolve interlocal disputes when informal negotiations have failed.	Jan. 25, 1995
Seminole County, Seminole County Supervisor of Elections and the municipalities of Casselberry, Lake Mary, Longwood, Oviedo, and Winter Springs	Poll Worker and Election Assistance Interlocal Agreement	Enhances the electoral process by causing voter access to polling places to be facilitated at the least possible cost to the public for countywide and city elections.	June 16, 1988 <del>self-renewing</del> <del>self-renewing</del> annually
Seminole County and the City	Interlocal Agreement	Provides government services (fire protection, public safety, emergency law enforcement, and road maintenance) to County citizens residing in defined "areas of concern". County to encourage property owners to seek annexation. Annexation of any parcels within this area is subject to this agreement.	Feb. 9, 1987
<b>PARKS AND RECREATION</b>			
Seminole County and the City	2nd Amendment to Interlocal Agreement for Design, Construction and Maintenance of the Cross Seminole Trail within the Town Center	Extends the City's maintenance responsibilities for the Cross Seminole Trail for one additional mile, from Central Winds Park to Layer Elementary and provides for the installation and maintenance of additional trees.	Nov. 7, 2006
Seminole County and the City	1 <sup>st</sup> Amendment to Interlocal Agreement for Design, Construction and Maintenance of the Cross Seminole Trail within the Town Center	Allows for realignment of Florida National Scenic Trail/Cross Seminole Trail. City to acquire land and maintain trail; county to design and construct trail; County to design, construct, and maintain SR 434 trail overpass.	Oct. 24, 2002 <del>self-renewing</del> <del>self-renewing</del> annually
Seminole County and the City	Black Hammock Trailhead Restroom Facility	Establishes -maintenance and cleaning responsibility for the restroom facilities located at the Black Hammock trailhead.	Oct. 12, 1999

Agreement Between	Type of Agreement	Details of Agreement	Agreement Dates
Seminole County and the City	Design, Construction, and Maintenance of certain sections of the Cross Seminole Trail within the City of Winter Springs Town Center	Allows for realignment of Florida National Scenic Trail/Cross Seminole Trail. City to acquire land and maintain trail; county to design and construct trail; County to design, construct, and maintain SR 434 trail overpass.	May 13, 1999 <del>self-renewing</del> <del>self-renewing</del> annually
<b>POTABLE WATER &amp; SANITARY SEWER</b>			
Seminole County and the City	Interlocal Agreement for Wholesale Water and Wastewater Service	Allows the City to connect to the County water and wastewater system and purchase 4,500 GPD water service capacity plus an additional 33,500 GPD and purchase 4,500 GPD wastewater capacity allocation at the Iron Bridge Regional Wastewater Treatment Plant plus an additional 30,000 GPD, on a wholesale basis from the County to serve the City's future customers.	Oct. 2, 2007 exp Oct. 2017 <del>self-renewing</del> <del>self-renewing</del> to 2027
Longwood and the City	Interlocal Agreement for U.S. 17-92 Establishing Municipal Service Area	Establishes a U.S. 17-92 Municipal Service Area and provides for the maximum efficient use of public infrastructure in the delivery of water and sewer service along the U.S. 17-92 Corridor and <del>identifies</del> corresponding annexation boundary for the City.	Sept. 8, 2005 for 30 years
Seminole County and the municipalities of Altamonte Springs, Casselberry, Lake Mary, Oviedo, Sanford, and Winter Springs	Countywide Water Supply Planning Interlocal Agreement	Develops a countywide water supply planning document.	Oct. 12, 2004
<b>PUBLIC SAFETY</b>			
<del>School Board and the City</del>	<del>Seminole County Public Schools School Resource Officer Agreement</del>	<del>Provides three full-time law enforcement personnel to perform the duties and responsibilities of School Resource Officers in certain Seminole County Public Schools.</del>	<del>July 1, 2008 exp June 30, 2009</del>
Seminole County and the City	Interlocal Agreement Consolidating the Winter Springs and Seminole Co. Fire Departments	Seminole County to provide the City with fire, rescue, and emergency medical services. Agreement details among other things, the financial considerations, transfer of employees, equipment and property.	June 23, 2008 effective Oct. 2, 2008



Agreement Between	Type of Agreement	Details of Agreement	Agreement Dates
Seminole County and the City	Interlocal Agreement for Fiber Optic Communication Network, First Amendment	Provides for the shared use of a Fiber Optic Communication Network (FOCN) which will enhance the ability of the parties to serve the residents and citizens of Seminole County through improved local government resources.	Oct. 14, 2003
Seminole County Sheriff's Office and the municipalities of Altamonte Springs, Casselberry, Lake Mary, Longwood, Maitland, Oviedo, Sanford, and Winter Springs.	Law Enforcement Mutual Aid Agreement	Provides assistance- in the form of law enforcement services and resources to adequately respond to continuing, multi-jurisdictional law enforcement problems, so as to protect the public's peace and safety, and preserve the lives and property of the people.	<del>2001-2005</del> <u>March 25, 2019</u>
State of Florida, Department of <del>Community</del> <u>Affair</u> <del>Economic Opportunities</del> and the City	Statewide Mutual Aid Agreement for Catastrophic Response and Recovery	Enhances the State's ability to plan for, respond to, and recover from a future disaster and allows the City to request assistance for major catastrophic disasters.	2001 <del>self-renewing</del> <u>self-renewing</u> annually
Seminole County and the City	Interlocal Agreement for Fiber Optic Communication Network	Provides shared use of a Fiber Optic Communication Network (FOCN) which will enhance the ability of the parties to serve the residents and citizens of Seminole County through improved local government resources.	Oct. 13, 2000
Drug Enforcement Administration and the City	Federal Equitable Sharing Agreement	Agrees to receive and share with the Treasury Department impounded equipment and forfeited money. City provides agent for DEA on heroin task force.	2000 <del>self-renewing</del> <u>self-renewing</u> annually
U.S. Government and the City	COPS Grant Equipment Federal Protective Armor Replacement	Provides the City with 50% reimbursement for protective body armor.	2000 <del>self-renewing</del> <u>self-renewing</u> annually
Orange County, Osceola County, and Seminole County and the municipalities of Altamonte Springs, Apopka, Casselberry, Kissimmee, Longwood, Maitland, Orlando, Oviedo, St. Cloud, Winter Springs and Winter Park.	Interlocal Agreement for Shared Use of Traffic Pre-Emption Systems	Provides assistance in obtaining the quickest and safest response to calls for emergency services and outlines the circumstances under which emergency vehicles of one party may utilize the traffic pre-emption system on public roads within another party's jurisdiction to pre-empt traffic signalization during an emergency response.	July 10, 1995

Agreement Between	Type of Agreement	Details of Agreement	Agreement Dates
Seminole County and the municipalities of Altamonte Springs, Casselberry, Lake Mary, Longwood, Oviedo, Sanford, and Winter Springs.	Interlocal Agreement for Seminole County's 911 Emergency Phone System	Establishes participation in the County 911 emergency system and coordination in assigning addresses.	1995 (est.)
Seminole County and the municipalities of Altamonte Springs, Casselberry, Lake Mary, Longwood, Oviedo, Sanford, and Winter Springs.	Interlocal Mutual Aid Agreement	Provides reciprocal mutual aid assistance between the First Response Group and the City.	1989 <del>self-renewing</del> <del>self-renewing</del> annually
<b>SOLID WASTE</b>			
Seminole County and the City	Interlocal Agreement for Solid Waste Management	Executing a ten year interlocal agreement with Seminole County committing the solid waste generated in Winter Springs to the Seminole County Landfill and receiving a Three Dollar per ton discount in consideration of that commitment. Includes recycling and amnesty days for residents.	Mar. 1, 2006 for 10 years then <del>self-renewing</del> <del>self-renewing</del> annually
Seminole County and the municipalities of Altamonte Springs, Casselberry, Lake Mary, Longwood, Oviedo, Sanford, and Winter Springs.	Interlocal Agreement	Establishes a management plan for the construction, operation and maintenance of solid waste facilities countywide.	1994
<b>TRANSPORTATION</b>			
Seminole County and the City	Interlocal Agreement for Maintenance of Landscaping, Hardscaping and Streetlighting, First Amendment	Revises funding of City's maintenance of landscaping, hardscaping and streetlighting for the SR 434 access management improvements under the County's Local Agency Program Agreement (LAP) with the FDOT.	June 15, 2006
Seminole County and the City	Interlocal Agreement for Traffic Signal Maintenance	Provides maintenance service by the County for traffic signals owned or partially owned by the City as identified and located along SR 419, SR 434 and Tuscawilla Rd.	Sept. 5, 2006

Agreement Between	Type of Agreement	Details of Agreement	Agreement Dates
Seminole County and the City	Interlocal Agreement Relating to the Transfer of Orange Avenue	Transfers the ownership and maintenance of Orange Ave. to the City.	Jan. 5, 2005
Seminole County and the municipalities of Altamonte Springs, Casselberry, Lake Mary, Longwood, Oviedo, Sanford, and Winter Springs.	Interlocal Agreement relating to the Optional One-Cent Fuel Tax Authorized by Florida Statutes Section 336 025 1 B	Imposes an additional one cent fuel tax upon every gallon of motor fuel sold in Seminole County for the purpose of funding ADA Transportation Fixed Bus Route Service and Public Transit.	2005
Seminole County and the City	Interlocal Agreement for Maintenance of Landscaping, Hardscaping and Streetlighting	Designates maintenance of landscaping, hardscaping and streetlighting for the SR 434 access management improvements under the County's Local Agency Program Agreement (LAP) with the FDOT to the City.	Mar. 23, 2004
FDOT and the City	Interlocal Agreement for Maintenance of Median Landscaping	Designates maintenance of median landscaping (SR 434 Access Management Program) to the City.	Dec. 8, 2003
FDOT and the City	Interlocal Agreement for State Highway Lighting, Maintenance and Compensation	Reimburses the City for state road street lighting costs.	July 10, 2002
FDOT and the City	Interlocal Agreement for Traffic Signal Maintenance and Compensation	Reimburses the City for state road traffic signal costs.	July 10, 2002
Seminole County and the City	Interlocal Agreement Relating to Spring Avenue Paving and Maintenance	Authorizes the County to pave and maintain Spring Avenue.	June 10, 2002

Agreement Between	Type of Agreement	Details of Agreement	Agreement Dates
Seminole County and the City	Interlocal Agreement for Road Transfers	Transfers road ownership, operation and maintenance to the City: Shepard Road, Brantley Avenue, Railroad Avenue, Milky Way, Natures Way, Old Sanford Oviedo Road, Nursery Road, and Magnolia Street. To the County: Boat Club Road, Jessup Road, Lake Street, Nancy Drive, Springs Avenue, Spring Drive, and Orange Avenue.	June 10, 2002
<del>Seminole County and the City</del>	<del>Interlocal Agreement funding design through construction of certain City streets including construction and maintenance of the Tuskawilla Rd. stamped asphalt project</del>	<del>Uses local government infrastructure sales surtax for road improvements by the City.</del>	<del>Oct 2001 expires 2011</del>
Seminole County and the municipalities of Altamonte Springs, Casselberry, Lake Mary, Longwood, Oviedo, Sanford, and Winter Springs.	Seminole County Transportation and Education Infrastructure Plan Interlocal Agreement	Provides for the distribution of the local government infrastructure surtax. The County and municipalities may use the money received to finance, plan, construct, and improve transportation projects (similar agreement -adopted in 1996).	June 28, 2001 expires 2011
FDOT and the City	Highway Maintenance Memorandum of Agreement	Reimburses maintenance activities on SR 434 (Contract No. AJ479)	Feb. 14, 2001
Seminole County and the City	Design, Construction, and Maintenance of Wall Project	Provides for the development of transportation improvements and enhancement of the quality of life for the benefit of the residents of the County and the City.	June 10, 1997
Seminole County and the City	Road Impact Fee Interlocal Agreement	Authorizes the City to collect County imposed impact fees for transportation for an administrative fee.	August 1996 self renewing annually on 10/1

Agreement Between	Type of Agreement	Details of Agreement	Agreement Dates
Seminole County and the City	Utility Engineering Design	Allows the performance of utility engineering services. City may contract for payment of utility services performed under the County's contract with a private engineering firm and the County is agreeable to providing services under the terms and conditions of the agreement.	March 14, 1996
Seminole County and the City	Interlocal Agreement for Traffic Signal Maintenance	Develops a coordinated effort for the repair of traffic signals whereby the County will maintain certain traffic signals installed by the City at a cost basis.	March 20, 1989
Seminole County and the municipalities of Altamonte Springs, Casselberry, Lake Mary, Longwood, Oviedo, Sanford, Winter Springs	Interlocal Agreement (Local Option Gas Tax)	Provides for the distribution of local option gas tax proceeds according to the agreement. Proceeds to be divided and distributed among the County government and eligible municipalities in accordance with the provisions of Section 336.025, Florida Statutes.	Sept. 3, 1986 in effect for the life of the taxes

Source: City of Winter Springs, February ~~2009~~2019.

Ron DeSantis  
GOVERNOR



Ken Lawson  
EXECUTIVE DIRECTOR

July 1, 2019

The Honorable Charles Lacey  
Mayor, City of Winter Springs  
1126 East State Road 434  
Winter Springs, Florida 32708

Dear Mayor Lacey:

The Department of Economic Opportunity ("Department") has completed its review of the proposed comprehensive plan amendment for the City of Winter Springs (Amendment No. 19-01ER), which was received and determined complete on May 3, 2019. We have reviewed the proposed amendment in accordance with the state coordinated review process set forth in Sections 163.3184(2) and (4), Florida Statutes (F.S.), for compliance with Chapter 163, Part II, F.S. The Department does not identify any objections or comments to the proposed amendment and this letter serves as the Objections, Recommendations and Comments Report. Review comments received by the Department from the appropriate reviewing agencies, if any, are enclosed.

The City should act by choosing to adopt, adopt with changes, or not adopt the proposed amendment. For your assistance, we have enclosed the procedures for final adoption and transmittal of the comprehensive plan amendment. **The second public hearing**, which shall be a hearing on whether to adopt one or more comprehensive plan amendments, **must be held within 180 days** of your receipt of the Department's attached report, or the amendment will be deemed withdrawn unless extended by agreement with notice to the Department and any affected party that provided comment on the amendment pursuant to Section 163.3184(4)(e)1., F.S.

If you have any questions related to this review, please contact Dan Pennington, Planning Analyst, by telephone at (850) 717-8524 or by email at Dan.Pennington@deo.myflorida.com.

Sincerely,

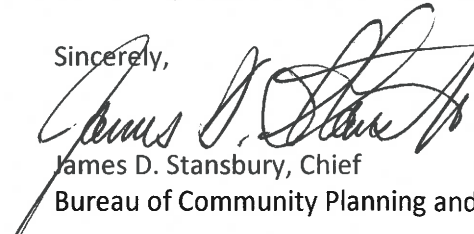

James D. Stansbury, Chief  
Bureau of Community Planning and Growth

JDS/dp

Enclosure: Procedures for Adoption  
Agency Comments

cc: Bryant Smith, P.E., CFM, Interim Community Development Director, City of Winter Springs  
Hugh Harling, Jr., P.E., Executive Director, East Central Florida Regional Planning Council

Florida Department of Economic Opportunity | Caldwell Building | 107 E. Madison Street | Tallahassee, FL 32399  
850.245.7105 | [www.FloridaJobs.org](http://www.FloridaJobs.org)  
[www.twitter.com/FLDEO](http://www.twitter.com/FLDEO) | [www.facebook.com/FLDEO](http://www.facebook.com/FLDEO)

An equal opportunity employer/program. Auxiliary aids and service are available upon request to individuals with disabilities. All voice telephone numbers on this document may be reached by persons using TTY/TTD equipment via the Florida Relay Service at 711.

**SUBMITTAL OF ADOPTED COMPREHENSIVE PLAN AMENDMENTS**

**FOR STATE COORDINATED REVIEW**

**Section 163.3184(4), Florida Statutes**

**NUMBER OF COPIES TO BE SUBMITTED:** Please submit three complete copies of all comprehensive plan materials, of which one complete paper copy and two complete electronic copies on CD ROM in Portable Document Format (PDF) to the Department of Economic Opportunity and one copy to each entity below that provided timely comments to the local government: the appropriate Regional Planning Council; Water Management District; Department of Transportation; Department of Environmental Protection; Department of State; the appropriate county (municipal amendments only); the Florida Fish and Wildlife Conservation Commission and the Department of Agriculture and Consumer Services (county plan amendments only); and the Department of Education (amendments relating to public schools); and for certain local governments, the appropriate military installation and any other local government or governmental agency that has filed a written request.

**SUBMITTAL LETTER:** Please include the following information in the cover letter transmitting the adopted amendment:

\_\_\_\_\_ Department of Economic Opportunity identification number for adopted amendment package;

\_\_\_\_\_ Summary description of the adoption package, including any amendments proposed but not adopted;

\_\_\_\_\_ Ordinance number and adoption date;

\_\_\_\_\_ Certification that the adopted amendment(s) has been submitted to all parties that provided timely comments to the local government;

\_\_\_\_\_ Name, title, address, telephone, FAX number and e-mail address of local government contact;

\_\_\_\_\_ Letter signed by the chief elected official or the person designated by the local government.



**ADOPTION AMENDMENT PACKAGE:** Please include the following information in the amendment package:

\_\_\_\_\_ In the case of text amendments, changes should be shown in strike-through/underline format;

\_\_\_\_\_ In the case of future land use map amendment, an adopted future land use map, in **color format**, clearly depicting the parcel, its existing future land use designation, and its adopted designation;

\_\_\_\_\_ A copy of any data and analyses the local government deems appropriate.

**Note:** If the local government is relying on previously submitted data and analysis, no additional data and analysis is required;

\_\_\_\_\_ Copy of executed ordinance adopting the comprehensive plan amendment(s);

**Suggested effective date language for the adoption ordinance for state coordinated review:**

"The effective date of this plan amendment, if the amendment is not timely challenged, shall be the date the state land planning agency posts a notice of intent determining that this amendment is in compliance. If the amendment is timely challenged, or if the state land planning agency issues a notice of intent determining that this amendment is not in compliance, this amendment shall become effective on the date the state land planning agency or the Administration Commission enters a final order determining this adopted amendment to be in compliance. No development orders, development permits, or development dependent on this amendment may be issued or commence before it has become effective. "

\_\_\_\_\_ List of additional changes made in the adopted amendment that the Department of Economic Opportunity did not previously review;

\_\_\_\_\_ List of findings of the local governing body, if any, that were not included in the ordinance and which provided the basis of the adoption or determination not to adopt the proposed amendment;

\_\_\_\_\_ Statement indicating the relationship of the additional changes not previously reviewed by the Department of Economic Opportunity to the ORC report from the Department of Economic Opportunity.

**From:** [Plan\\_Review](#)  
**To:** [Eubanks, Ray](#); [DCPexternalagencycomments](#)  
**Cc:** [Plan\\_Review](#)  
**Subject:** Winter Springs 19-1ER Proposed  
**Date:** Friday, May 24, 2019 11:49:50 AM  
**Attachments:** [image002.png](#)

---

To: Ray Eubanks, DEO Plan Review Administrator

Re: Winter Springs 19-1ER – State Coordinated Review of Proposed Comprehensive Plan Amendment

The Office of Intergovernmental Programs of the Florida Department of Environmental Protection (Department) has reviewed the above-referenced amendment package under the provisions of Chapter 163, Florida Statutes. The Department conducted a detailed review that focused on potential adverse impacts to important state resources and facilities, specifically: air and water pollution; wetlands and other surface waters of the state; federal and state-owned lands and interest in lands, including state parks, greenways and trails, conservation easements; solid waste; and water and wastewater treatment.

Based on our review of the submitted amendment package, the Department has found no provision that, if adopted, would result in adverse impacts to important state resources subject to the Department's jurisdiction.

Please submit all future amendments by email to [plan.review@floridadep.gov](mailto:plan.review@floridadep.gov). If your submittal is too large to send via email or if you need other assistance, contact Lindsay Weaver at (850) 717-9037.



**From:** [Steve Fitzgibbons](#)  
**To:** [DCPexternalagencycomments](#)  
**Cc:** [Eryant Smith](#)  
**Subject:** City of Winter Springs proposed comprehensive plan amendment 19-1ER  
**Date:** Thursday, May 23, 2019 11:30:51 AM  
**Attachments:** [RF City of Winter Springs Water Supply Facilities Work Plan Update Central Florida Water Initiative Regional Water Supply Plan.mso](#)  
[WSFWP.mso](#)

---

Dear Mr. Eubanks,

St. Johns River Water Management District (District) staff have reviewed City of Winter Springs proposed comprehensive plan amendment 19-1ER. District staff review, as outlined in Florida Statutes, focused on flood protection and floodplain management, wetlands and other surface waters, and regional water supply. District staff have no comments on the proposed amendment. However, the following technical assistance is provided relative to regional water supply.

**Nomenclature changes**

1. Several comprehensive plan policies and sections (e.g., Policy 1.1.6, Policy 1.4, Section C.2.c) refer to the District Water Supply Plan (DWSP). In 2015, the District approved the Central Florida Water Initiative Regional Water Supply Plan (CFWI RWSP). Subsequently, the 2015 CFWI RWSP replaced the DWSP. Because of this nomenclature change, those policies and section which refer to the DWSP should be revised to reference the CFWI RWSP.

**Update of City's Water Supply Facilities Work Plan**

2. The District previously contacted the City regarding the need to update their Water Supply Facilities Work Plan (WSFWP) within 18 months (i.e., by May 2017) of governing board approval of the 2015 CFWI RWSP. The District is also providing this email as an additional reminder about the requirement to adopt an updated WSFWP and related comprehensive plan amendment. To find more information about the CFWI RWSP please visit [cfwiwater.com](http://cfwiwater.com).

If you have any questions or need additional information, please contact me. Please note that all proposed and adopted comprehensive plan amendments can be submitted to the District by email at [sfitzgibbons@sjrwmd.com](mailto:sfitzgibbons@sjrwmd.com).

Sincerely,  
Steve Fitzgibbons

Steven Fitzgibbons, AICP  
Intergovernmental Planner  
Governmental Affairs Program  
St. Johns River Water Management District  
7775 Baymeadows Way, Suite 102  
Jacksonville, FL 32256  
Office (386) 312-2369  
E-mail: [sfitzgibbons@sjrwmd.com](mailto:sfitzgibbons@sjrwmd.com)  
Website: [www.sjrwmd.com](http://www.sjrwmd.com)

Connect with us: [Newsletter](#), [Facebook](#), [Twitter](#), [Instagram](#), [YouTube](#), [Pinterest](#)



[www.sjrwmd.com/epermitting](http://www.sjrwmd.com/epermitting)

We value your opinion. Please take a few minutes to share your comments on the service you received from the District by clicking this [link](#)

#### Notices

- Emails to and from the St. Johns River Water Management District are archived and, unless exempt or confidential by law, are subject to being made available to the public upon request. Users should not have an expectation of confidentiality or privacy.
- Individuals lobbying the District must be registered as lobbyists (§112.3261, Florida Statutes). Details, applicability and the registration form are available at <http://www.sjrwmd.com/lobbyist/>

**From:** [Steve Fitzgibbons](#)  
**To:** [bfields@winterspringsfl.org](mailto:bfields@winterspringsfl.org); [rstevenson@winterspringsfl.org](mailto:rstevenson@winterspringsfl.org)  
**Cc:** [ksmith@winterspringsfl.org](mailto:ksmith@winterspringsfl.org)  
**Subject:** RE: City of Winter Springs Water Supply Facilities Work Plan Update – Central Florida Water Initiative Regional Water Supply Plan

---

Dear Mr. Fields:

In November 2015, the respective governing boards of the St. Johns, South Florida, and Southwest Water Management Districts approved the 2015 Central Florida Water Initiative Regional Water Supply Plan (CFWI RWSP). In May 2016, the St. Johns River Water Management District (District) contacted local governments within the CFWI area regarding the need to update their Water Supply Facilities Work Plan (Work Plan) within 18 months of governing board approval of the CFWI RWSP. The District is providing this email as a reminder to local governments about the requirement to adopt updated Work Plans and any related comprehensive plan amendments by May 2017. To find more information about the CFWI RWSP please visit [cfwiwater.com](http://cfwiwater.com).

District staff are available to assist local government planning staff as they amend their comprehensive plan to update the Work Plan. If you have any questions regarding updating a Work Plan, or would like to discuss the comprehensive planning requirements, please let me know.

Sincerely,

**Steve Fitzgibbons**

Steven Fitzgibbons, AICP

Intergovernmental Planner

Governmental Affairs Program

St. Johns River Water Management District

7775 Baymeadows Way, Suite 102

Jacksonville, FL 32256

Office (386) 312-2369

E-mail: [sfitzgibbons@sjrwmd.com](mailto:sfitzgibbons@sjrwmd.com)

Website: [www.sjrwmd.com](http://www.sjrwmd.com)

Connect with us: [Newsletter](#), [Facebook](#), [Twitter](#), [Instagram](#), [YouTube](#), [Pinterest](#)



[www.sjrwmd.com/epermitting](http://www.sjrwmd.com/epermitting)

**From:** Steve Fitzgibbons

**Sent:** Friday, May 06, 2016 11:20 AM

**To:** [rstevenson@winterspringsfl.org](mailto:rstevenson@winterspringsfl.org)

**Cc:** [ksmith@winterspringsfl.org](mailto:ksmith@winterspringsfl.org); Nancy Christman

**Subject:** City of Winter Springs Water Supply Facilities Work Plan Update – Central Florida Water Initiative Regional Water Supply Plan

Dear Mr. Stevenson,

In November 2015, the respective governing boards of the St. Johns, South Florida, and Southwest Water Management Districts approved the 2015 Central Florida Water Initiative Regional Water Supply Plan (CFWI RWSP). The CFWI RWSP Area encompasses all of Orange, Osceola, Polk and Seminole counties and southern Lake County. The CFWI RWSP contains an assessment of projected water demands and potential sources of water to meet these demands through 2035. Thank you for your entity's participation in the development process and for ensuring the CFWI RWSP is balanced,

addresses the water supply related issues of the region and provides a framework to meet the water needs of the CFWI RWSP Area through 2035.

To promote consistency between your comprehensive plan and the CFWI RWSP, Section 163.3177(6)(c)3, Florida Statutes, requires each local government within the CFWI RWSP Area to update its Water Supply Facilities Work Plan (Work Plan) within 18 months after governing board approval of the CFWI RWSP. The Work Plan must cover at least a 10-year planning period, identify alternative and traditional water supply projects, and conservation and reuse activities needed to meet the projected future demands. For local governments that are wholly or partially in the CFWI RWSP Area, Work Plans must be updated **by May 2017**.

For local governments located within the boundaries of more than one water management district, comprehensive plan amendments and Work Plans need to be provided to each water management district. The water management districts emphasize the need for close coordination with local governments and potable water suppliers to determine how future water needs will be met in the region.

To find more information concerning the CFWI RWSP and information regarding the process please visit the District's website at [www.sjrwmd.com/watersupply/CFWIinitiative](http://www.sjrwmd.com/watersupply/CFWIinitiative). District staff are available to assist your planning staff as they amend the comprehensive plan to update the Work Plan. Information about Work Plan-related requirements can be found on our website.

Please visit [cfwiwater.com](http://cfwiwater.com) to access the CFWI RWSP and associated appendices. If you have any questions regarding updating your Work Plan, or would like to discuss the comprehensive planning requirements, please let me know.

Sincerely,

**Steve Fitzgibbons**

Steven Fitzgibbons, AICP

Intergovernmental Planner

Governmental Affairs Program

St. Johns River Water Management District

P.O. Box 1429 • Palatka, FL 32178-1429

Office (386) 312-2369

E-mail: [sfitzgibbons@sjrwmd.com](mailto:sfitzgibbons@sjrwmd.com)

Website: [www.sjrwmd.com](http://www.sjrwmd.com)

Connect with us: [Newsletter](#), [Facebook](#), [Twitter](#), [Instagram](#), [YouTube](#), [Pinterest](#)



[www.sjrwmd.com/epermitting](http://www.sjrwmd.com/epermitting)



*Florida Department of Transportation*

RON DESANTIS  
GOVERNOR

719 South Woodland Boulevard  
DeLand, Florida 32720

KEVIN J. THIBAUT, P.E.  
SECRETARY

May 13, 2019

D. Ray Eubanks  
Plan Processing Administrator  
Division of Community Planning  
Florida Department of Economic Opportunity  
107 East Madison Street, MSC-160  
Tallahassee, FL 32399

**SUBJECT:** PROPOSED COMPREHENSIVE PLAN AMENDMENT  
**LOCAL GOVERNMENT:** CITY OF WINTER SPRINGS  
**DEO #:** 19-01ER

Dear Mr. Eubanks,

The Department of Transportation has completed its review of the above Comprehensive Plan Amendment as requested in the City of Winter Springs transmittal letter dated May 1, 2019.

We appreciate the opportunity to participate in this review process. The proposed EAR-based text amendments are not anticipated to result in significant adverse impacts to the State Highway System or the Strategic Intermodal System. The Department has no technical assistance comments regarding the proposed amendments.

If you have any questions, you may contact Tina Williamson at 386-943-5150 or by e-mail at [Tina.Williamson@dot.state.fl.us](mailto:Tina.Williamson@dot.state.fl.us).

Sincerely,

Jean Parlow  
Growth Management Coordinator

*Attachment*

C: Bryant Smith, City of Winter Springs  
Rebecca Hammock, Seminole County  
Fred Milch, ECFRPC  
Kellie Smith, FDOT  
Jennifer Carver, FDOT  
Kelly Corvin, FDEO



---

## PROPOSED COMPREHENSIVE PLAN AMENDMENT REVIEW

**Local Government:** City of Winter Springs  
**DEO Amendment #:** 19-01ER  
**Date Amendment Received FDOT:** 05/01/2019  
**Review Comments Deadline:** 05/31/2019  
**Today's Date:** 05/13/2019

---

### GENERAL BACKGROUND INFORMATION

The City of Winter Springs has submitted the proposed Winter Springs 19-01ER large scale Comprehensive Plan Amendment for Evaluation and Appraisal Review (EAR) based text amendments pertaining to the Intergovernmental Coordination Element of the *City of Winter Springs Comprehensive Plan*.

### TEXT AMENDMENTS

**Elements:** Intergovernmental Coordination  
**Rule Reference:** Chapter 163, Florida Statutes

### Background:

The transmittal indicates this amendment is an update to the City's Comprehensive Plan based on an Evaluation and Appraisal Review related to the Intergovernmental Coordination Element. The proposed EAR-based text amendments are summarized below:

1. Update plan names and dates.
2. Revise dates in various policies.
3. Remove policy granting ECFRPC authority to regulate Developments of Regional Impact (DRIs).
4. Update agency names and addresses.
5. Update Table VII-1: Inventory of Existing Interlocal Agreements to reflect new dates and expired agreements. No changes to agreements between the City and FDOT are proposed.

### Technical Assistance:

The proposed text amendments are not anticipated to have significant adverse impacts to the State Highway System (SHS) or the Strategic Intermodal System (SIS). The Department has no technical assistance comments at this time for this proposed amendment.

The Department respectfully requests a copy of the adopted plan. Please provide the adopted plan within two weeks of adoption, in order to assist in facilitating review within the required 30-day time frame from adoption, as required by Statutes (State Coordinated Review Process Section 163.3184(4), Florida Statutes).

---

<b>FDOT Contact:</b>	Tina Williamson, AICP In-house Consultant FDOT District 5, Planning & Corridor Development/PLEMO	<b>Reviewed by:</b>	Tyler K. Johnson, AICP  Vanasse Hangen Brustlin, Inc.
<b>Telephone:</b>	386-943-5150		407-839-4006
<b>Fax:</b>	386-943-5713		407-839-4008
<b>E-mail:</b>	<a href="mailto:Tina.Williamson@dot.state.fl.us">Tina.Williamson@dot.state.fl.us</a>		tjohnson@vhb.com
<b>File:</b>	\\d5.dot.state.fl.us\d5dfs\Deland\Development\PLEMO\Planning\Growth Management\CPA\CPA Project Files\Winter Springs_Seminole\EAR\2019\19-01ER\Proposed\Winter Springs Proposed 19-01ER - CPA Review.docx		



# REGULAR AGENDA ITEM 500

CITY COMMISSION REVISED AGENDA  
AUGUST 12, 2019 | REGULAR MEETING

## TITLE

City Manager Position

## SUMMARY

On March 25, 2019, City Commission approved a contract appointing Shawn Boyle as Interim City Manager effective April 8, 2019.

Section 5.01 of the City Charter provides that the City Commission, by the affirmative vote of not less than four (4) commission members, shall appoint a city manager and fix the manager's compensation. The city manager shall be appointed solely on the basis of executive and administrative qualifications and shall serve at the pleasure of the commission.

On June 11, 2019, the City published notice soliciting candidates for the permanent City Manager Position. The deadline for candidates to submit qualifications for the position was August 1, 2019. Approximately 230 applicants timely submitted resumes.

During the July 8, 2019 City Commission meeting, there seemed to be consensus on the City Commission for the City Attorney and IT/Administrative Services Director to preliminarily sort through the received resumes to separate the experienced, relevantly qualified applicants from the other applicants. Further, each City Commissioner could individually identify such applicants to present to the City Commission.

Therefore, based on the City Commission's discussion at the July 8, 2019 meeting, the City Attorney and IT/Administrative Services Director, preliminarily sorted all resumes received for the City Commission's convenience into two very general categories: (1) candidates with relevant experience as a city or county manager or assistant city or county manager; and (2) candidates without such city or county manager experience. The Experienced Candidate List is presented in alphabetical order by last name. ("Experienced Candidate List").

Note: The other candidates without relevant city or county manager experience had varying levels of experience ranging from serving in a variety of other local government positions (e.g., mayor, public works director, housing authority

director) to having absolutely no local government or management experience whatsoever.

At this stage of the process, it is premature to conduct reference and background checks on any of the candidates until further direction is given by the City Commission.

The City Commission should review the Experienced Candidate List of relevantly experienced candidates, and any other candidates identified by any of the City Commissioners individually, and take whatever action the City Commission deems appropriate and necessary in its discretion to permanently fill the position of City Manager pursuant to Section 5.01 of the City Charter.

In addition, at the July 8, 2019 City Commission meeting, the City Commission scheduled a special meeting for August 21st at 6:30 regarding the City Manager position.

## **RECOMMENDATION**

The City Commission should review the Experienced Candidate List of relevantly experienced candidates, and any other candidates identified by any of the City Commissioners individually, and take whatever action the City Commission deems appropriate and necessary in its discretion to permanently fill the position of City Manager pursuant to Section 5.01 of the City Charter.

## City of Winter Springs/City Manager Position

	Candidate Name	Current or Former Position	Employer or Residence	Page #'s
1	Anderson, Andy	Former Acting Deputy City Manager	Palm Bay, Florida	2-4
2	Anderson, Calvin	Former Deputy City Manager/Municipal Consultant	Coconut Creek, Florida	5-9
3	Andrews, Scott	Assistant City Administrator	Smyrna, Georgia	10-14
4	Boyle, Shawn	Interim City Manager	Winter Springs, Florida	15-17
5	Coffey, Craig	County Manager	Flager County, Florida	18-21
6	Coleman, Kyle	Assistant to Village Manager	Village of Estero, Florida	22-26
7	Davis, Steven	Former County Administrator	Effingham County, Georgia	27-29
8	Douglas, Richard	City Manager	Covington, Virginia	30-34
9	Dowling, Randall	County Manager	Harris County, Georgia	35-40
10	Ellis, Jacob	Deputy Town Manager	Town of Gilbert, Arizona	41-43
11	Faulkner, Daniel	Village Manager	Lawrence, Michigan	44-46
12	Feik, Dylan	Former City Manager	Calistoga, California	47-50
13	Fuhrer, Mathew	Assistant City Manager	Cocoa, Florida	51-54
14	Garside, Mathew	Town Manager	Poland, Maine	55-59
15	Girdler, Darin	City Administrator	East Moline, Illinois	60-61
16	Hoch, Ernest	Former County Administrator	Culpeper/Madison, Virginia	62-67
17	Jefferson, Alphonso	Assistant County Administrator	Broward, Florida	68-72
18	Kolata, John	Former City Manager	Fernandian, Florida (residence)	73-77
19	Newhouse, Ben	City Manager	Hurricane, West Virginia	78-81
20	Shanahan, William	County Manager	York County, South Carolina	82-84
21	Strohl, David	Chief Administrative Officer	Forsyth, Illinois	85-91
22	Talkington, Molly	Former Interim City Manager	Dekalb, Illinois	92-95
23	Truver, Kelli	City Manager	Sleepy Eye, Minnesota	96-98
24	Vitas, Bogdan	Former Town Manager	South Beach/Key West, Florida	99-104

\* *Approximately 230 candidates applied - list represents only candidates with relevant city/county manager experience referenced on resume*

\* *Sorted alphabetically by last name*

# **Sorted List**

# **City Manager Candidates**

**August 12, 2019**

# Andy Anderson

## **Director of Economic Development and External Affairs - City of Palm Bay**

Palm Bay, FL 32907

aande0876\_9k7@indeedemail.com

(321) 749-2916

A seasoned and dynamic professional with more than 25 years of background in executive local government management, economic development, political affairs, small business operations, and federal government contract management. Demonstrated expertise in communicating messages to appropriate levels within diverse organizations. Strong interpersonal skills with proven integrity. Proficient in preparing high-level executive correspondence and material for external meetings, public events, and hearings. Thrives in working both independently and in a collaborative environment. Experienced in managing multiple priorities, crises, and overcoming complex operational challenges and assuming full responsibility for making high-stakes decisions.

Willing to relocate: Anywhere

## Work Experience

---

### **Director of Economic Development and External Affairs**

City of Palm Bay - Palm Bay, FL

2015 to Present

Palm Bay, FL

Directly supervises the Palm Bay economic development, legislative and marketing team. Oversees the city's redevelopment agency and related initiatives. Recruits new businesses and helps grow those businesses already located in the City of Palm Bay. Manages and implements economic policies to increase investment in the city's tax base. Works with department directors and management team to develop and implement long-range goals, strategies, and plans for marketing the City of Palm Bay. Responsible for establishing and maintaining relationships through interactions and communications with legislative bodies.

### **Acting Deputy City Manager**

City of Palm Bay - Palm Bay, FL

May 2018 to June 2019

Palm Bay, FL

Performed a variety of responsible staff management duties, tasks, and projects for the City Manager. Work involved overseeing multiple City departments as assigned by the City Manager. Assisted the City Manager in the performance of a variety of general administrative tasks and special projects. Was responsible for coordinating various organizational projects and support functions. Acted as the City Manager in the absence of the City Manager. Interacted with elected officials, regulatory bodies, and local authority staff.

### **Brevard County Commissioner**

Brevard County, Florida - Melbourne, FL

2008 to 2016

Adopted ordinances and policies to carry out both the County and local powers and purposes. Reviewed budgetary requests, including salaries, and make the final fiscal determinations and appropriations for all county government operations. Heavily involved in economic development projects that assisted in the recovery of Brevard County's workforce.

### **City Council Member / Deputy Mayor**

City of Palm Bay - Palm Bay, FL  
2003 to 2007

Palm Bay, FL

Duties included the review and approval of the City's budget and performed legislative functions of government by developing policies for the management of the City of Palm Bay.

### **Internet Sales Manager**

Space Coast Harley-Davidson - Palm Bay, FL  
2003 to 2007

Worked cooperatively with outside sales and other members of the distribution team to grow existing customers, create new customers and meet or exceed monthly sales quotas at the appropriate gross margin while increasing customer satisfaction.

### **Finance Controls Manager**

Johnson Controls - Kennedy Space Center, FL  
1998 to 2003

Responsible for the administration of Space Center projects and liaising closely with the prime contractor on all aspects of cost control and financial compliance reporting. Acted as liaison between project and external auditors and independent consultants. Worked closely with a finance team to assess risks and influences on project finances and provided quality assurance support.

### **Small Business Owner**

A. A. Anderson Investigations - Palm Bay, FL  
1992 to 1997

Small business owner responsible for the oversight and management of office duties along with daily operations of the business to include: Management of employees, performing primary tasks related to bookkeeping, marketing, advertising, and payroll.

## Education

---

### **Master's Degree in Public Administration**

Florida Institute of Technology  
January 2017 to Present

### **Bachelor's Degree in Public Administration**

Florida International University

### **Associate Degree in Business**

Eastern Florida State College (BCC)

## Skills

---



Marketing, budget, training, Powerpoint, Strategic Planning, retail sales, Word

## Military Service

---

**Branch: Army**

Service Country: United States

Rank: E-3

December 1987 to July 1990

Military Police Investigator - U.S. Army Drug Suppression Team

Duties included the investigation of criminal activity with emphasis involving illegal narcotics. These functions encompassed covert surveillance and undercover operations. Responsible for the coordination of U.S. military assets with local law enforcement agencies to identify individuals, or groups, which attempted to distribute illicit substances to U.S. service members.

## Awards

---

**Honors & Activities**

Founded and coordinated the Coats for Kids drive in 2010, collecting over 2500 coats for needy Brevard County school children, chaired the Cystic Fibrosis Foundation's Brevard Great Strides walk, served as Chairman for the Riverside District of the Boy Scouts of America - Central Florida Council. I was named Humanitarian of the Year for 2010-11 by the South Brevard Sharing Center and the Florida Guardian ad Litem Program's 2013 Community Advocate of the Year for the 18th Judicial Circuit.

Previously served as a board member of the Space Coast Economic Development Commission, Space Coast Transportation Planning Organization, Central Florida Regional Planning Council, Tourism Development Council, Public Safety Coordinating Council, and Election Canvassing Board. I am also active in The International City / County Management Association, The Florida City and County Management Association, The International Economic Development Council, Leadership Florida, and The Honor Society of Phi Kappa Phi.

## Additional Information

---

<https://www.linkedin.com/in/andy-anderson-335b5bb/>

CALVIN, LLOYD ANDERSON

5544NW 54<sup>TH</sup> Circle: Coconut Creek FL 33073

Telephone (954) 481-9733 or (954) 261-1985

E-Mail: Mr. C\_anderson @ Hotmail.com

### Professional Summary

Visionary, Strategic, and innovative forward-thinking City manager who is passionate about local government service and work collaboratively with the Mayors and commissioners to set out a clear statement of the respective roles and responsibilities of the leadership Team and members of staff. A manager who is a strategic thinker and will position the City operations for sustainable community growth and development that will benefit all members of the community. A leader who is a mediator with the ability to negotiate on behalf of the City and forge positive partnerships and relationships with other agencies. A Manager with an outstanding professional reputation and the utmost personal and professional impeccable integrity. Accountability and transparency.

#### CITY MISSION AND INITIATIVES:

The City's Mission: The City of Winter Springs Commission is a dedicated group of elected officials who put serving the public above all else. The Commission is made up of a Mayor and four Commission members and is delighted in having a dedicated, personable, knowledgeable, experienced, and forward-thinking Manager and staff that enjoy working as a team and have a "Community of Communities" attitude which will naturally generate a desire to produce successful and quality work. The City departments are supported by the Commissioners.

**Key Initiatives:** The City Mayor and Commission Members maintains dashboards related to the City's Performance, Sustainability and Transformation Investment Plan to establish a collaborative working relationship with the City Manager, City Commission, Business Partners and Community groups to focus on building cash reserves to fund the unexpected as well as planned improvement infrastructure projects and Staff of the PUC, and City Commission genuinely want the best for their community.

#### Skills

- **Leadership:** Managerial and interpersonal skills to lead a dynamic, financially fit organization in a community with high customer-service expectations, community activism and demand for government transparency.
- **Communication skills:** Ability to work with a very engaged Mayor and City Commission being supportive of their efforts and initiatives while at the same time able to help to delineate and preserve the roles of the elected officials and the appointed City Manager
- **Financial management Skills:** Abilities, lead and monitor financial forecasting, revenue enhancement, capital improvement programming, and budget development and control.
- **Interpersonal Skills:** Ability to be approachable and welcoming at the same time being articulate and able to think in working with the media in a diverse community is essential.
- **Problem-solving Skills:** leading a high-performing workforce in a positive, cooperative, and team-oriented approach to addressing issues.
- **Organizational skills:** Ability to review the structure of the City organization, departments, services, projects and other issues make recommendations to commission for change.
- **Economic Planning/ Development Skills:** Directs economic, planning and community development efforts including attracting new business and retaining and strengthening existing businesses.
- **Strategic Planning Skills:** Engage team, commissioners, citizens, and business, through discussion.
- **Community Engagement Skills:** Engage community into the City operations and keep them informed.

#### RELEVANT LOCAL GOVERNMENT EXPERIENCE

**VP /CHIEF Performance Manager, IABCS Municipal Consulting:** Coconut Creek FL ,Jan 2014 Present  
Plan, direct, manage and oversee the administration of municipal operations under supervision of the Mayor and Commission as well as coordinate assigned activities with City departments and outside agencies, administer policies established by the Mayor and City Council for efficient operation of the municipality, and provide highly responsible administrative support to the Mayor and City Council in legislative, policy, fiscal, and other technical matters. .

- Plans, directs, and oversees City operations, programs, and services and ensures systems are in place to evaluate and promote quality, cost-effectiveness, and responsiveness to the needs of the City and its residents and to ensure a coordinated and efficient effort to meet goals and objectives established by the City Council.

- Represents the City with other governmental agencies and officials; monitors activities related to municipal government.
- Prepares and presents the annual budget to the City Council; keeps the Council informed of the financial condition of the City; suggests major capital expenditures for City Council approval.
- Develops and issues administrative rules, policies, and guidelines to ensure proper functioning of all departments and superior provision of City services
- Supervises all City staff directly or indirectly through department supervisors; acts as final authority on all personnel actions.
- Oversees preparation of the City Council agenda and prepares or approves supporting documentation; attends and participates in all Council meetings and other official meetings as needed.
- Drafts or oversees preparation of City ordinances, resolutions, and policies for City Council approval and executes official papers and documents on behalf of the City.

**Key Achievements:**

- ◆ Fosters cooperative working relationships with State and local intergovernmental and regulatory agencies and various public and private groups; to pursue appropriate avenues of economic and community development.
- ◆ Manage and invest City funds in accordance with City Council guidelines and sound financial practices; Oversee and manage financial accounting matters.
- ◆ Implementation of proper planning, expenditure tracking and audit of financial resources, including extra- budgetary income in accordance with municipal rules and regulations.

**Director/Chief Internal Auditor:** Ghazi District Council Botswana Jan 2010 – Jan 2013

Provided executive leadership assisting the City manager with executing a budget of \$ 89 Million general fund Full time employees of 573 and population of approximately 90,000.with full responsibilities for strategic long-range planning, budget development and providing cross function management for CFO, HR, five other department heads.

- Ensured that all laws, provisions of the Charter and acts of the City Commission, subject to enforcement by the Manager or by Officers subject to the Manager’s direction and supervision, are faithfully executed
- Lead the operations, ensuring smooth functioning of the City/programmers projects operations, consistent services delivery and constant evaluation and readjustment of the operations to consider changes in the operating environment as and when needed
- Provided summaries of the overall effectiveness of the quality management system(QMS) including information on the strengths and weaknesses of the management operations system, continual improvement; and other key performance indicators
- Reviews department head personnel and pay decisions and/or recommendations and resolves or advises on resolution of employee complaints or grievances.; open new and alternative solutions to challenges within the organization and issues to be resolved by the Mayor and Council

**Key Achievements:**

Restored morale and build a high-performance management team by restructuring and developing existing staff for succession planning; eliminated a layer of bureaucracy to become responsive to residents' needs

Ensures full compliance of operations with City charter rules, regulations and policies, implementation of corporate operational strategies, establishment of management targets and monitoring of achievement and the operational environment .

Public utilities: reorganizing Utilities operations to let them operate like a private business, improving cash handling procedures, profit & loss and internal controls by instituting daily bank deposit and monthly bank statement

Monitoring and Control of City cash management processes, including liquidity management, recommendation of impress level, risk assessment, bank relationship management; timely accounting and reconciliation of all financial transactions, including purchasing and contracts, stewardship of all City assets and resources.

**Chief financial Officer:** Genesis Business Corp, Lauderhill FL 3331 February 2002 – Dec 2009  
.Management all financial operations based on analysis of financial information and knowledge of the organization objective and plan, Oversees and directs the accounting process and participates in budget

development revision and activities such as cash flow management, cost allocation, analysis, asset management, financial problems.

Accounting for \$ 325 million in revenues and ensuring compliance with Company regulations as well as generally accepted accounting Principles. (GAAP)

- Develop and execute the annual budget after approval by the board of directors and monitor the Capital and operating budget to ensure control

**Achievements:**

- Dramatically improved labor-management relations eliminating a two-year grievance backlog and Cost.
- Developed and implemented a long-range plan to manage user fees leading to a projected six million dollars in new revenues in the first year.
- Applying strong internal controls in all areas of financial management, risk management and asset control.

**Deputy City Manager:** Pompano Beach, Broward County FL 33736 June 1993 – Jan 2002

Pompano Beach City Has a population of 115,000 covering 26 square miles approximately; General Fund budget is \$114 000.000

Responsible for leading the promotion and delivery of the organization good financial management; safeguarding all City assets and using resources appropriately, economically, efficiently and effectively; Coordinated the administration of all city departments Develops, directs, implements, and controls the City's annual budget to ensure the City's fiscal integrity and attain the City Council's goals and departmental operating objectives.

- Supervised the fiscal services of the City including accounting, collections, budgeting, purchasing and financial reporting, auditing, policies and regulations as deemed appropriate by the city manager.
- Represents the city, both internally and externally, at community function events, presentations, committees and professional group meetings as assigned by the city manager and assists with city-wide functions such as development of budgets, policies and regulations as deemed appropriate by the city manager.
- Represents the city, both internally and externally, at community function events, presentations, committees and professional group meetings as assigned by the city manager and assists with city-wide functions such as development of budgets, policies and regulations as deemed appropriate by the city manager.
- Coordinated special projects for the City, including the planning, design, implementation, and evaluation of construction/renovation projects, management studies, introduction of new programs.

**Key Achievement**

**Promoted diversity** of City with a goal of having a public service that reflects the population it serves and champion inclusion and respectful behavior in the workforce and community; Integrate diversity objectives into the city-wide structures include identifying and implementing workforce data collection, developing and implementing a Positive Space program and increasing senior leadership knowledge of equity and diversity issues.

**Ensured Operations compliance** with City rules and regulations in the field and implementation of City Office procurement strategies including sourcing strategy, supplier selection and evaluation, quality management, customer relationship management, e-procurement promotion and introduction, performance measurement.

**Economic Development** lead Directs of economic development planning and community development efforts including attracting new businesses and retaining and strength Tsing existing businesses and agriculture and technology.

**Encourage public engagement** and provide added value to citizens when visiting City facilities and participating in Council, Community and Committee meetings, and when accessing government services.

**Labor and contracts Negotiation** Deals with high-growth management issues and negotiating with labor Unions representatives and contractors to ensure construction of quality projects that will be in the best interest of the City and community

### **Challenges and Opportunities:**

The City Manager will play a key role in the continuously evolving and changing role of city government. In addition to the day-to-day operations, other major issues and challenges include:

- ◆ Improve City facilities and services;
- ◆ Re-stabilize the City of Winter Springs organization;
- ◆ Have adequate financial resources to support required infrastructure improvements, defined services, and service levels
- ◆ Align City organization with the City's mission and core beliefs;
- ◆ Leverage City resources through grants and partnerships;
- ◆ Increase resident's understanding of City vision, goals, plans services, and programs as well as finance.

### **Management, knowledge, skills and abilities:**

- ◆ Well versed in a working knowledge of finance and budgeting;
- ◆ Knowledge of FEMA disaster preparedness (Hurricanes) and disaster recovery policies and procedures;
- ◆ A demonstrated ability to successfully work with other legislative bodies, elected and appointed officials; county, municipal, state, and federal;
- ◆ Assist in the continued development of Delray Beach as a destination for businesses, new residents, and tourists
- ◆ Implement short- and long-term capital improvement plans, projects, and budgets.
- ◆ Politically astute without being political;
- ◆ Work with leadership staff to develop a comprehensive understanding of City operations.
- ◆ Professional, consistent, and impartial in dealing with staff, citizens, and the City Commission;
- ◆ Practical knowledge of public safety services including Fire Rescue and Police;
- ◆ A proven track record in economic development;
- ◆ A good grasp of Community Redevelopment Agencies;
- ◆ An understanding of the City's Comprehensive Plan.
  - ◆ Develop productive relationships with local economic development entities and help develop strategies for enhancing economic growth in the community.
- ◆ Work With applicable community groups, develop strategies for redevelopment and enhancement of housing options

### **Education and Experience:**

- ◆ Master's in Public Administration: Majored in Management Policies in Local Government Accounting, Finance and Risk management: From Long Island University Graduate School of Management: Brooklyn New York City, NY.
- ◆ 12-15 plus years of progressively responsible experience in municipal government as a City Deputy Manager, Chief Financial officer, Director of Internal Audit and Local Government, Compliance manager.
- ◆ Bachelor of Science; Business Administration: Majored in Advance Accounting / Auditing: From Long Island University, Brooklyn, New City, New York.
- ◆ Master's Thesis in Human Resource Administration Long Island University
- ◆ Previous municipal and local government experience; including experience with fund accounting and managing a pension plan.

- ◆ **Advanced legal knowledge.**
- ◆ **Advanced budget knowledge.**
- ◆ **Driver's License is Available.**

---

# C. SCOTT ANDREWS, Ed.D.

1455 SPRING RD #158 SMYRNA, GA 30080  
(813) 943-3405 CSCOTTANDREWS@GMAIL.COM

---

A decisive leader with excellent communication and interpersonal skills seeking an opportunity to use my professional experience, education and unquestionable integrity to lead a progressive local government. Sixteen years of responsible municipal management experience with substantial experience in city management, economic development, partnerships, strategic vision plans, placemaking, conflict resolution, citizen engagement, event execution, recreation, capital budgeting and community engagement.

---

## EDUCATION

Ed.D in Organizational Leadership	Argosy University	December 2015
M.P.A. Public Administration	Strayer University	September 2008
B.S. Business Management	University of South Florida/University of Phoenix	September 2007

## PROFESSIONAL EXPERIENCE

---

**CITY OF SMYRNA, GA** (60,000 residents)      SEPTEMBER 2017 - PRESENT  
Assistant City Administrator

- Acts as City Administrator as needed.
- Under general policy direction of City Administrator and Mayor; plans, implements and directs a comprehensive program for the City's long-range growth.
- Adopted "Hands Free" ordinance which was then adopted by other cities, followed by GA.
- Assists and advises Mayor & Council in establishing overall policies, researches Council requests regarding policy, and prepares and submits recommendations.
- Orchestrates highly productive departments ranging from Engineering, Recreation, I.T., Museum, Library, Environmental Services and the City's Vision Plan.
- Serves as C.I.P. and SPLOST chair during budget process and approves all budget amendments
- Assists with preparation of the City's \$92 million annual budget and C.I.P. plan.
- Interacted directly with and acted as the liaison to City Council members responding to questions and drafting correspondence and reports.
- Served as a liaison with the City Attorney to investigate, research, and compile data for ongoing or pending legal action.
- Provided leadership and direction in the development of short and long range plans; gathered, interpreted, and prepared data for studies, reports and staff recommendations.
- Established and maintained effective working relationships with local state, and federal agencies, regional authorities, civic organizations, the media, and intergovernmental relationships with other cities.
- Provided guidance to department directors regarding personnel matters to include promotions, demotions, hiring, and disciplinary actions.
- Attended conferences, schools, and professional meetings to keep abreast of new developments in public administration, training and economic development.
- Served as the architect for the creation of City's open container/entertainment district resulting in exponential sales and economic development opportunities for the defined business areas.
- Exercises responsible judgment in resolving problems involving citizens.
- Participates with labor relations and negotiations.
- Leads all efforts for the 2020 census process for the City.
- Represents the City on different boards, commissions and agencies.



- Orchestrated a highly motivated team responsible for marketing, communications, events, outreach, and business attraction for the City.
- Led downtown revitalization efforts, serving as both the Secretary/Treasurer and lead staff person for the downtown development authority.
- Collaborated with consultants on traffic studies, void/retail leakage analysis, City master plans, hotel feasibility studies, greenway studies, and executed development agreements for private sector projects ranging from full service hotels to large scale mixed-use developments.
- Initiated the largest municipal event series in Georgia with an event attendance and exposure increase of 31% from 2014 to 2015, and 404% from 2013 to 2017.
- Facilitated 14 city-based interests groups ranging from Arts Commission, award-winning Youth Council and Players Guild to Historic Preservation, Women’s Club and Business Alliance.
- Led the project development and implementation of the transformation of the old city hall into an award-winning business incubator and coworking space called “The Suite Spot.” This project also serves as a host site for several free business resources for business owners.
- Co-founded the Sugar Hill Business Alliance in 2014, which became the largest group of its kind in Gwinnett County.
- Founded the Gwinnett Communications & Events Committee to create cohesion and coordination between the 16 cities in Gwinnett County.
- Interacts with City Council on a regular basis ranging from preparing speeches and PowerPoint presentations to presenting proclamations, policies and specific agenda items at City Council meetings.

- Responsible for direct management of 5 recreation facilities, 15 parks, and nearly 60 staff members; departments ranged from fitness, athletics and facility rentals to customer service to aquatics.
- Prepared annual operating and capital outlay budgets (\$3 million/ \$115K-\$460K) for the division and assisted with the development of the larger department-wide budget as well.
- Served as representative for the city’s pension and contract negotiation team.
- Planned and implemented policies, practices and procedures for the department which resulted in 15% savings in facility use staffing costs.
- Facilitated and implemented youth and adult athletic leagues and related programming. During tenure, the documented a 100% increase in adult sports league revenues.

## **PROFESSIONAL AFFILIATIONS, ACHIEVEMENTS**

---

### International City-County Management Association

ICMA Credentialed Manager Candidate

Selected to the Leadership ICMA class of 2021

Presenter at 2019 ICMA Conference in Nashville

Selected to Management Exchange Program (Rockville, MD) 2018

ICMA Advisory Board on Graduate Education – 2016 - present

---

ICMA Student Chapter Founder/Mentor (Georgia Gwinnett College & Clark Atlanta University)

Knowledge Network Advisory Board member - 2012-2014, 2016 - present

Small Community Scholarship Recipient - 2011

Emerging Leaders Development Program - 2011-2013

Georgia City-County Management Association

Leads all "Next Generation" sessions for Aspiring City/County Managers

Professional Development Committee and Technology Committee - 2015 - present

Scholarship Committee – 2014

National Development Council – Economic Development Finance Professional Certification – 2017

University of Georgia: CVIOG Georgia Certified Economic Development Program - 2017

Gwinnett Chamber of Commerce – Community Wellness Award - 2016

Partnership Gwinnett – Influence Award - 2015

Gwinnett Young Professionals – Gwinnett Chamber of Commerce - Founding Board Member - 2015

Explore Gwinnett: "Friend of Gwinnett Tourism" winner - 2014

Georgia Academy for Economic Development - 2014

Georgia Downtown Association

Georgia Downtown Association Board Member - 2015 - 2017

Downtown Development Authority Advanced Training - 2015

Florida City and County Management Association

"If You Care, You Do" Award Recipient - 2013

Emerging Leader Scholarship Recipient - 2012

Professional Development Committee - 2012-13

Conference Planning Committee - 2011-13

Intergovernmental/Organization Partnerships Committee - 2011

Florida Recreation and Park Association

Training and Education Committee Chair - 2013

Central Region Director - 2013

Annual Conference Committee - 2008, 2012

Central Region Planning Committee - 2011-Present

Joe Abraham's Academy for Leadership Excellence - 2008

National Recreation and Park Association

Certified Parks and Recreation Professional (CPRP) Certification – 2011-2017

Aquatics Facility Operator Certification - 2007 - present

National Incident Management Systems (ICS) 400, 700, 800, (IS) 1

American Red Cross CPR, AED, First Aid, and Lifeguard certified – 2007- present

## **PUBLIC ADVISORY BOARDS**

Gwinnett Transit Collaborative member - 2017

Gwinnett Clean & Beautiful Advisory Board member - 2015-17

Gwinnett Tech Marketing and Management Advisory Board member – 2014-17

Partnership Gwinnett Entrepreneurial Council – 2014- 2017

Lanier High School Advisory Board Member – 2015-17  
 Hillsborough County Child Care Facilities Advisory Board - 2012  
 Hillsborough County Water Conservation Technical Advisory Committee - 2009-2012  
 Hillsborough County Human Relations Board - 2008-2009  
 Secretary for Hidden Oaks (Temple Terrace, FL) Home Owners Association - 2007-2008  
 City of Temple Terrace Library Board - 2005

**MEMBERSHIPS AND COMMUNITY INVOLVEMENT**

Selected to Leadership Cobb – 2018-19  
 “Dancing With the Stars” Cobb County Schools fundraiser participant - 2019  
 Principal for the Day – Campbell High School - 2018  
 Selected to Leadership Gwinnett – 2017-18  
 Distinguished Gentlemen Mentor Program - Lanier High School - 2015-2017  
 Principal for the Day & Half Hour Hero Mentor program - Sugar Hill Elementary 2016  
 North Gwinnett Kiwanis – 2014-2017  
 Sigma Beta Delta International Business Honor Society  
 General Manager for Continental Basketball League’s Tampa Bay Saints – 2012-2015  
 Assistant Coach for King and Strawberry Crest High School Basketball teams 2011-2014  
 Chairman of Kappa Sigma Fraternity (University of South Florida) – 2001

**REFERENCES**

Tammi Saddler-Jones City Administrator Smyrna, GA 832-969-8266	Max Bacon Mayor Smyrna, GA 770-436-3824	Ron Fennel Councilmember Smyrna, GA 678-592-9011	Derek Norton Mayor Pro-Tem Smyrna, GA 404-274-4210
Paul Radford City Manager Sugar Hill, GA 770-605-4073	Steve Edwards Mayor Sugar Hill, GA 770-560-4025	Brandon Hembree Councilmember Sugar Hill, GA 404-372-3270	Taylor Anderson Councilmember Sugar Hill, GA 678-472-5743
Corkey Welch Councilmember Smyrna, GA 404-626-3893	Cheri Donohue Councilmember Temple Terrace, FL 813-230-3389	Susie Gajewski Councilmember Sugar Hill, GA 678-761-2634	Marc Cohen Councilmember Sugar Hill, GA 770-789-6048
Dr. Bob Lee Executive Director CFLGE 239-777-1013	Randall Reid Southeast Director ICMA 941-445-3567	Carl Harness Human Svces. Hillsborough Cty, FL 813-766-9196	Janice Eidson Admin. Director of Mgmt Georgia Municipal Association 678-686-6256



**Shawn D. Boyle**

(407)792-8466 sboyle@winterspringsfl.org

Extensive experience and interest in:

Financial System Management

Budget Planning/ Forecasting

Utility and Sewer Operations

Construction/Project/Contract Management

Financial Reporting

Strategic Analysis and Implementation

Economic Development

**Professional Experience**

**City of Winter Springs, FL**

**2010-Present**

*Currently serving as Interim City Manager*

**Achievements:** Completed redistricting in record time, increased rating on pension plan from E to A, submitted budget in surplus, largest decrease in taxes since 2006, lowest millage rate in the county, completed largest pavilion in the City's history, streamlined development application process by rewriting City code.

*Director of Finance and Administrative Services*

Served as Director of HR, IT, Building Permits, Utility Management and Billing, Risk Management. Directs the preparation of financial reports and schedules. Reviews and approves financial materials such as: budgets, checks, pay requests, memorandums, payroll timesheets, etc. Reviews financial data, such as: bond documents, monthly financial reports, other reports and funding requests. Manages City pension plan (net position ending \$54M). Attends and participates in administrative meetings, such as: agenda preparation, staff, department head, Commission, Tuscowilla Lighting and Beautification and Pension board. Coordinates the annual audit. Prepares routine and special reports, analysis and management studies. Prepares and monitors the City's \$52M budget. Oversees investment and management of City investments. Exercises general supervision over various assigned activities. Develops programs, City-wide policies and procedures. Initiates and carries to completion special programs as directed by the City Manager. Manages the disposition of surplus assets. Prepares and implements Customer Service Plan. Represents and defends the City in legal matters.

**Achievements:** Reduced healthcare cost by 30% over ten years, restructured debt and reduced annual requirements by \$15 million, reduced headcount by 26% while increasing the level of customer service, implemented new ERP system, redesigned and implemented new City Web page included self-service e-commerce portals for utilities, parks and building inspections, restructured employee pension, reduced annual cost by \$1 million and past service liability by \$30 million.

\*\*\*\*\*

**Oldham County Fiscal Court, LaGrange, Kentucky**

**2005-2010**

*CFO*

**2006-2010**

Manage all financial reporting and accounting for the Company. Present financial data, reports and results to the Board of Directors and provide guidance and recommendations for policies, procedures and budgetary decisions. Identify and achieve optimal capital/debt structures. Responsible for all strategic financial planning and implementation, as well as all state and federal grants.

**Achievements:** Reduced operating expenditures by 10% and increased operational revenues by 12% in FY2008 by a radical reorganization, restructuring, and reducing workforce by 15%. Replaced labor with long term capital investments and technology. Appointed as Vice Chair of the Board of Directors for the Oldham County Sewer District.

***Treasurer/Controller***

**2005-2006**

Perform critical cash management processes and treasury service functions including: cash management, investing, cash forecasting and credit line administration. Analyze and implement ways to leverage existing and new technologies to enhance service, data management, analytical and reporting. Provide treasury business expertise and support for the ongoing enterprise and business unit use of systems. Work with enterprise IT resources to maintain system operational capabilities. Complete monthly reconciliations and month closing processes. Communicate with the program managers at the end of each month to confirm that existing programs are still being executed as they were reflected in the prior reforecast. Confirm actual results with budgeted results to determine why variances exist.

\*\*\*\*\*

**Brown-Forman Corporation, Louisville, Kentucky**

**1996-2004**

Company Description: Manufacturing - One of the largest American-owned companies in the spirits and wine business, a diversified producer and marketer of various consumer products

***Lead Financial Analyst: Property Plant and Equipment***

**1999-2004**

Complete annual budgets, monthly variance analysis, assess capital interest (SFAS No.34), generate written communications of consolidated asset position to Brown-Forman's board quarterly, manage Brown-Forman's \$1.3B fixed asset portfolio, load and reconcile load companies in order to create consolidated income statements and balance sheets, negotiate/manage lease contracts.

**Achievements:** Reduced capital spending 30% by implementing new guidelines and policies, captured \$2.3 million in depreciation savings annually and created documentation for Sarbanes-Oxley.

***Financial Analyst: IT***

**1996-1999**

Develop and maintain financial reporting models for all levels of management including senior executives, monitor and report expense/revenue progress, conduct capital expenditure analysis on all major I/S purchases (NPV), maintain cost models for I/S product lines, develop and coordinate budgeting presentations for I/S management, Coordinate I/S contracts with internal and external distributors.

**Achievements:** Automated the financial reporting systems within I/S, modified and expanded monthly executive reports to improve communication between all levels of management, consolidated and simplified the annual I/S budget process by creating sophisticated spreadsheet and data collection tools, implemented a capital asset program.

\*\*\*\*\*

**Prudential Healthcare, Louisville, Kentucky**

**1994-1996**

Company Description: Healthcare - Acquired by SHPS several years ago.

***Manager, Financial Analysis***

Finance team leader (40 associates); construct and maintain economic and financial models for strategic management, cash flow management including daily/monthly cash deposit reconciliation; construct and monitor six departmental budgets; analyze and develop new pricing strategies for products; forecast monthly/annual revenues; develop and maintain product unit costs; negotiate and review client contracts;

develop quotes for all new business acquisitions; develop and support senior management strategy initiatives.

**Achievements:** Increased revenues by aggressively managing cash flows (\$500M); increased cash velocity by automating cash application process; successfully implemented an activity based management unit cost program; negotiated several large contracts to obtain new clients; acted as liaison between operational units and senior executives; introduced an added value unit cost program.

\*\*\*\*\*

**Providian Capital Management, Louisville, Kentucky**

**1992-1994**

Company Description: Financial Services - Now AEGON, investment operations.

**Operations Analyst**

Develop, staff, and motivate special projects; analyze and direct funds for department budgets and accounts payables; negotiate outside vending contracts; maintain employee benefit records; quality review disbursement register reconciliations; coordinate customer financial statements and provide backup for security of all mainframe systems.

**Achievements:** Developed Lotus spreadsheets to automate pension administration; identified and recovered approximately \$125,000 with an internal audit of individual annuity contracts; learned to manage multiple projects with strict deadlines while maintaining accuracy and quality; gained excellent product knowledge of annuities; became proficient in the use of mainframe systems and LAN.

**Education**

**Murray State University, Murray, Kentucky**

**2000**

Master of Science in Economics and Finance

Major Area of Study: Corporate Finance and Macro/Micro Economics

**Murray State University, Murray, Kentucky**

**1991**

Bachelor of Science in Business

Major: Business Administration (AACSB) accredited program

Major Area of Study: Management Strategies, Accounting, Finance and Corporate Law

**Additional Skills/Awards**

Computer Literate: (i.e. Microsoft Word, Excel, Power Point, Project Manager, Lotus 123, Word Perfect, TSO, SQL, SAP, Great Plains), working knowledge of AIRMA and regression models, working knowledge of security analysis. 1998 Brown-Forman Achievement Award and several performance awards.



## **RESUME**

### **Craig Michael Coffey**

10 Trail Run, Flagler Beach, FL 32136

(386) 264-3696 (cell)/[cgc Coffey@cfl.rr.com](mailto:cgc Coffey@cfl.rr.com)/(386) 868-9226(alt)

## **OBJECTIVE**

**To be a City Manager for a forward-thinking community, with a high quality of life, that continually strives for excellence.**

## **EDUCATION**

**Master of Public Administration, University of Central Florida, Orlando, FL**

**B.S., Land Use Analysis (Planning), Eastern Michigan University, Ypsilanti, MI**

## **RELEVANT PROFESSIONAL EXPERIENCE**

**County Administrator, Flagler County, Florida - 2007 to 2019**

Responsibilities Included: Oversight and management of all day-to-day aspects of the County. This included nearly 400 full-time employees, in a variety of typical and atypical county departments, plus enterprise funds (Water, Sewer, Solid Waste, and Airport). Financial responsibilities involve developing/managing a \$66 million general fund budget, within a \$220 million overall budget, over 1.1 million sf of public building space and over 10,000 acres of public land, a fleet of more than 800 vehicles, \$30-\$50 million in capital projects annually, and hundreds of contracts and services annually.

### **Major Accomplishments:**

- Led and/or managed three major natural disasters (Fire-5,000 acres+ and Hurricanes) before, during and after to include over \$50 million in long term recovery projects – County, FEMA, and HMPG projects. Essentially served as incident commander for Hurricanes Matthew and Irma.
- Acquired two small private water and sewer utility systems.
- Created voluntary and mandatory special assessment districts for capital projects such as seawalls, protective dunes, and a stormwater retrofit project.
- Negotiated multiple, multi-year, union contracts for firefighters (IAFF) and one contract with the PEA union. Was able to include fitness-for-duty provisions and incentives for special teams for firefighters.
- Led the County through the great recession when the County lost half of its taxable property valuation and led the state in unemployment and mortgage foreclosure – strategies were comprehensive and included such things as: service realignments and mission essential evaluations, cost cutting, cost saving investments, new revenue sourcing, layoffs and restructuring, and line-item budgeting.
- Successfully passed an Environmentally Sensitive Lands (ESL) Funding Voted Referendum, 20-year Local Option Sales Tax; and increased Tourism Tax Rate by 2%.
- Obtained millions in State legislative appropriations, successfully passed and blocked State legislation in accord with the legislative priorities of the County Commission.
- Privatized Custodial Services, Landscaping Maintenance, & Interfacility Ambulance Transport Services.
- Successfully merged the City of Bunnell Fire Department into the County's Fire/Rescue Department.
- Brought Economic Development and Tourism in-house as County Departments. Since then, Economic Development helped create more than 400 jobs, \$200 million in economic output, and \$22 million in capital investment since coming in-house. Likewise, Tourism increased revenues by over 30%.
- Led transfer of tourism tax collection from the State Dept. of Revenue to the County Tax Collector.
- Worked jointly w/Supervisor of Elections to Upgrade Election Equipment and Cyber Security.
- Refinanced all County debt saving County taxpayers millions of dollars.

- Secured new financing for over \$100 million in funding for over 20 different financing instruments.
- Improved the County's Bond Rating from A+ to AA- saving millions in debt issued/refinanced.
- Created an employee clinic and fitness facility, plus implemented a comprehensive incentivized wellness program, and affiliated Canada drug prescription program.
- Managed County's self-insured health insurance program to nearly flatline health insurance costs to include reinsurance, with minimal changes in benefits to County employees.
- Completed hundreds of millions of dollars in capital projects including road construction and resurfacing, bridges, parks, stormwater, utilities, beautification, and government buildings, including a new County Jail and new I-95 County Interchange. On average \$30-\$50 Million per year.
- Merged Sheriff fleet and Sheriff IT operations w/County BOCC saving money and gaining efficiencies.
- Acquired two new constitutional outreach service facilities and leased and remodeled another.
- Recruited and retained an all-star staff recognized at State and National levels.
- Created a popular citizen's academy for citizen outreach and to develop volunteer pool.
- Developed in-depth new employee orientation program w/organizational cultural emersion.
- Created a 11+ mile, 25million+ Dune Protection/Restoration Project, with funding from the tourism tax, FDEP, Private HOA, a CDD, and FEMA funding to prevent the reflooding of hundreds of homes, prevent homes from collapse into the ocean, and to protect millions more in infrastructure and homes. Constructed project in-house, 209 private property easements (97% success), FDEP and ACOE permits, turtle relocation, 3 interlocal agreements w/other local governments.
- Acquired over 6,000 public acres during tenure and managed over 10,000 passive park acres.
- Successful as local sponsor with Army Corps of Engineers in obtaining National Civil Works Review Board approval for a 2.6-mile Shoreline Protection Project in Flagler Beach.
- Successful in obtaining \$17 million in federal funds for initial construction of 2.6 mile, ACOE project plus an additional \$16 million from FDOT for the remaining 3.65 miles of City of Flagler Beach shoreline (6.25 miles in total).
- Constructed over 20 miles of new multipurpose trails and over 8 miles of new mountain bike trails.
- Airport – Worked to bring County Executive Airport into black - County owned spaces fully occupied, built new hangars and new air traffic control tower, acquired over 70,000 sf of market space in foreclosure purchase for \$2.75 million; constructed new runway; rebranded airport; opened south side of airport for economic development with infrastructure (130 developable acres), added 172 additional acres to airport, constructed over \$35 million in new airport capital improvement projects, repaid inherited, State economic building grant in default; Attracted new Florida National Guard facilities in excess of \$30 million.
- Revamped budget for transparency and ease of citizen use, 9 budget awards (10<sup>th</sup> in progress)
- Begin High School Fire Leadership Academy with EMT (Certificate Eligible -1<sup>st</sup> in State) to develop pipeline of local firefighter-paramedics.
- Built a free public potable water supply point for disadvantaged rural residents with private donations.
- Created community paramedicine program to conduct home visits and stop frequent flyers.
- Created Ocean Rescue Program to overcome Coast Guard coverage gap -- based on citizen initiative.
- Expanded ALS Paramedic Ambulance Service into west side to improve rural response times.
- Worked to keep the State of Florida Agricultural Museum open as a County tourism destination by obtaining direct state support and grants, restructuring organization, integrating some county support and constructing improvements/infrastructure.
- Developed partnerships with City of Bunnell, School Board, and County and others to restructure funding, operations, and mission to keep the Carver Gym (Community Hub) open in a disadvantaged neighborhood. Assisted forming foundation, annual auction, outside funding support agreements
- Developed a contiguous, \$1.6 million, ocean seawall project from start-to-finish and coordinated 19 property owners with voluntary assessment to save homes and property following Hurricane Matthew.

## **County Administrator, DeSoto County, Florida - 2005 to 2007**

Responsibilities Included: Oversight and management of all aspects of the County. This included 225 full-time employees, in a variety of typical county departments (Fire/EMS, Landfill, Public Works, Finance/Purchasing, Parks, Development) plus enterprise funds (Water, Sewer, Solid Waste, and Civic Center). Financial responsibilities involve developing/managing a \$24 million general fund budget, within a \$90 million overall budget. Also, served as Clerk on the Board (1944 special act) for everything outside of courts and recording – i.e. handled audits, attestation, payroll, check issuance.

### **Major Accomplishments:**

- Negotiated a 30 Year, 4 County, Interlocal Agreement and Master Water Supply Agreement as a member of a Regional Water Supply Authority. (Led negotiations for the County)
- Secured the free donation of a 160acre, \$2.4 Million Wastewater Treatment Plant Site.
- Developed a Water-Sewer Utility Business Plan to include Capital Projects to bring the utilities from start-up mode to profitability to include securing over \$8,000,000 of private upfront capital.
- Developed, negotiated, and oversaw the merger of the City-County Fire/EMS Departments.
- Initiated a Countywide Demolition Program leading to over 107 Demolitions (previously none)
- Oversaw the rebuilding and reopening of a \$10 million Agri-Civic Center following Hurricane Charley with booked daily events ranging from \$5,000 to \$100,000 in scope.
- Attracted and located several large manufacturers with new jobs and millions of dollars of new capital investment in the County.
- Resolved Landfill cell construction stoppage in order to construct new cell opened March 2007.
- Implemented first ever County curbside garbage collection program in 2006.
- Completed massive rewrite of County's Comprehensive Plan Amendment written by previous administration and consultant after poor ORC report from DCA.
- Created Housing Department by reassigning excess staff and administered \$10 million grant for post hurricane housing recovery to include unique plan to closeout FEMA housing parks.
- Developed extensive Adult Entertainment and Mining Ordinances.
- Began Small Quantity Generator (HAZMAT) program as required by law and new ongoing Fire/Life Safety Inspection Program.
- Managed major CIP projects including two major park projects, \$15,000,000 of utility improvements and millions in transportation improvements.

## **City Administrator, City of Hawarden, Iowa - 1999 to 2005**

Responsibilities Included: Oversight and management of all aspects of the City. This included 32 full-time employees and 20+ seasonal employees, in a variety of typical city departments (Police, Public Works, Finance, Parks, Ambulance, Recreation, etc.), plus 9 Utilities (Water, Sewer, Gas, Electric, Telephone, Cell Phone, Cable, High Speed Internet, and Solid Waste). Financial responsibilities involved developing/managing a \$12 million operating budget (\$20 million total resources). In addition, I also served as the Economic Development Director for the Hawarden Area Partnership for Progress (HAPP).

### **Major Accomplishments:**

- Initiated/Facilitated the merger of the Development Corporation and Chamber of Commerce.
- Facilitated the partnering of multiple groups to undertake a \$2.4 million combined City Hall, Community Center, and Child-Care Campus Project to include the passage of a \$950,000 bond referendum, grants, project development, and construction (Historic. 1925 High School)
- Re-wrote Employee Personnel manual, re-negotiated union contracts, implemented training certifications w/incentives, and re-established a uniform program, working with City employees.
- Re-formed and chaired a six-county regional economic development and marketing group.

- Brought the City's new telecommunications utility from start-up in 1999 to profitability. In addition, I was instrumental in expanding additional telecommunication services to include: High-speed Internet, Cell Phone Service, HDTV, 8 new analog channels, and a 150 new Digital TV channels, yet still saving citizen-ratepayers over \$100,000 per year in fees.
- Directly responsible for the receipt of over ten grants worth more than \$500,000 dollars.
- Started the televising of Council meetings, re-started City newsletter, increased press coverage, and significantly expanded City information of the City's Website and community channel.
- Re-negotiated existing, outside City fire service contracts (Cross State), contracted with a smaller, nearby community to provide them 24-hour police protection, and utilized police dept. as code enforcement.
- Reconstructed a destroyed historic downtown building and restored another.
- Issued eight bond/debt issues, implemented ten TIF projects, worked to facilitate multiple business expansions, and re-developed several downtown historic projects.
- Awarded GFOA CAFR audit award 5 consecutive years,
- Completely re-vamped budget format for citizen understanding.
- Develop a detailed capital improvement plan for equipment and facilities.
- Initiated and oversaw the creation of two new residential subdivisions built by the City.

### **Director of Planning & Public Works, City of Mayfield, Kentucky - 1993 to 1999**

Responsibilities Included: Oversight and Management of all aspects of the City outside the offices of Police, Fire, and City Clerk. This oversight/management included 22 full-time employees, 4 seasonal employees, and 3 seasonal subcontractors.

#### **Major Accomplishments:**

- Recognized with three state level awards.
- Received 9 out of 9 grants applied for bringing in over \$750,000 in monies.
- Established the City's first ever fire prevention/code enforcement department.
- Re-wrote the City's Comprehensive Plan and most land development regulations.
- Completely re-developed three City parks and created a new park.
- Initiated a Main Street program to re-develop the downtown including the re-development of several downtown buildings and beginning of the downtown streetscape project.
- Created a comprehensive city sidewalk replacement program resulting in the replacement of miles of sidewalk at a reduced cost to the City.
- Designed and developed major drainage improvements citywide protecting homes and property.
- Negotiated a large annexation for the development of a new shopping center south of the City
- Represented the City with the State DOT on eminent domain process for a new bypass.

### **City Planner (Equal to Planner III), City of Melbourne, Florida - 1988 to 1993**

Responsibilities Included: Infrastructure capacity management, re-writing land development regulations, site plan reviews, writing recommendations to the BZA, Planning and Zoning Board, and City Council, comprehensive plan amendments, census forecasts, regional project reviews, re-development area planning, advising on various CDBG and CIP Projects, budget development and submittal, downtown re-development, facility location studies, and business license review.

### **Captain, Military Police Officer, U.S. Army Reserves, - 1984 to 2000**

Responsible Positions Served: Company Commander, Platoon Leader, Battalion S-1 (Admin), S-3 (Training/Operations), etc. Served over 8 months of active duty service with the 810<sup>th</sup> MP Company (Tampa) as a Platoon Leader attached to 82<sup>nd</sup> Airborne in Saudi Arabia and Iraq in support of Operation Desert Shield/Storm. First reserve unit to ever earn 82<sup>nd</sup> Airborne combat patch. Formally ended service in January 2003 to devote more time to family and civilian positions.

**REFERENCES AND ADDITIONAL INFORMATION AVAILABLE UPON REQUEST**

ACCOMPLISHED PUBLIC AND BUSINESS ADMINISTRATION LEADER

**KYLE B. COLEMAN** MPA, MBA  
**Fort Myers, FL 33916**

 kylecoleman@gmail.com



 +1 (585) 880-0698

**LEADERSHIP**

- COMMUNITY ENGAGEMENT
- ECONOMIC DEVELOPMENT
- ETHICS-DRIVEN LEADERSHIP
- TECHNOLOGY UTILIZATION
- STRATEGIC PLANNING
- PERFORMANCE MANAGEMENT
- COUNCIL RELATIONS
- CRISIS MANAGEMENT
- BUSINESS IDEATION

**PUBLIC ADMINISTRATION - BUSINESS ADMINISTRATION - FINANCIAL MANAGEMENT**

An accomplished leader, I have improved public services in a financially and ecologically sustainable manner for the Village of Estero, Florida in my position as Assistant to the Village Manager. Accomplished by utilizing the power of public-private partnerships, and intelligent employee management together with the creative application of emerging technology. All while addressing legacy public liabilities.

With an enduring commitment to ethical clarity, being the best, perseverance, accountability and equality, I have leveraged my skills and experience to develop and implement impactful and cost-effective solutions. Specifically, my efforts produced positive outcomes in CIP, Finance, Public Works, Technology, Permitting, Plan Review, Parks and Recreation, Human Resources, and Disaster Response.

My career achievement is complemented with a **Master of Public Administration** in State and Local Government Financial Analysis and Management, a **Master of Business Administration** in Finance, a **Bachelor of Science** in Accounting, Finance, Information Management/Technology, a **Bachelor of Arts** in Economics, and a **Certificate of Advanced Study** in Health Services Management and Policy.

A proficient public presenter and communicator, I maintain composure, a calm demeanor, and decisiveness in high-stress environments. Outside the workplace I enjoy taking road trips, training to run a marathon, competing in basketball and tennis, and spending time with family, friends, and my dog.

**SELECTED CAREER ACCOMPLISHMENTS**

**Strategic:** Developed inaugural Village Strategic, Annexation and Branding plans, to guide the Village’s future growth. Refining and strengthening Council, Board, and Staff ethics code (the process is ongoing at this time).

**Intergovernmental Relations:** Grew relationships with partner agencies, culminating in \$40MM of outside funding for Village CIP projects. Analyzed agreements between neighbor cities, detailing areas of service overlap and potential cooperation.

**Finance:** Built and implemented the inaugural Capital Improvement Plan, with projects totaling in excess of \$100MM. Authored and implemented the inaugural Reserves policy, creating the region’s largest per capita reserves fund.

**Parks and Recreation:** Facilitated the \$24.5MM purchase of 62 acres for parks, including site planning, financing, and public outreach.

**Grant Application and Administration:** Applied for, received and managed a \$20,000 grant for additional marine patrol services along Estero River. Coordinated grant submission and stakeholder advocacy for \$5 million grant (outcome unknown at this time).

**AREAS OF EXPERTISE**

- |   |                          |                                    |
|---|--------------------------|------------------------------------|
| ◆ Budget Development/Oversight          | ◆ Conflict Resolution    | ◆ Grant Application/Administration |
| ◆ Capital Program Evaluation/Management | ◆ Brand Development      | ◆ Public-Private Partnership       |
| ◆ Intergovernmental Relations           | ◆ Risk Management        | ◆ Human Capital Management         |
| ◆ Intermediate Spanish                  | ◆ Process Re-engineering | ◆ Special Event Coordination       |
| ◆ Public Relations                      | ◆ Customer Service       | ◆ Technical Writing                |

MS Word, Excel, PowerPoint, Access, Project, Google Suite



## CAREER PROGRESSION

### ASSISTANT TO THE VILLAGE MANAGER

#### Village of Estero, Florida

July 2016 – Present

*Estero, near Naples, is a village in Lee County, Florida serving ~ 40,000 citizens during the warmer months and ~ 60,000 in the winter. It is the home of Hertz Arena, which hosts home games for the Florida Gulf Coast University, as well as Miromar Outlet and Coconut Point regional shopping centers.*

**Recruited by the Village Manager, who only recruits from the top 2-3 public administration programs in the country (Syracuse University, Maxwell College - my alma mater - is ranked #1 nationally). Department administrators recommended me as one of the top two students from the program and I came aboard to provide administrative leadership, as the fifth full-time employee for a city of 45,000, given my unique background in Technology, Finance, and Public Administration.**

**Public Works:** Created and managed the Village Public Works department, reducing annual costs by \$2 million (77% cut). Executed municipal contracts for most service functions, limiting staff growth to one part-time employee.

**Disaster Response:** Led Village response to Hurricane Irma, including operations and internal and external communications. Negotiated service agreements that lessened cash flow impact by \$5.7 million as compared to neighbor cities. Navigated the FEMA review process in order to receive full reimbursement for all Village projects.

**Community Development:** Overhauled permit review and code enforcement processes, consolidating 40+ application forms to 1. Implemented department-wide performance metrics, leading to a 30% reduction in data input efforts.

**Technology:** Designed and built a resident request for action system, as well as performance metrics tracking software. Revamped the technology used by the Clerk's office, reducing public records response time and cost by 90%.

**Human Resources:** Oversaw recruiting, hiring and onboarding of six full and part-time staff members. Utilized part-time help to maintain the regions lowest staff per capita ratio (1 employee per 4,000 residents). Maintained zero ongoing liabilities by recruiting and hiring with a defined contribution retirement plan.

**Public Safety:** Created and managed interlocal agreements with fire districts and data sharing partnership with the sheriff's office.

**Facilities:** Directed design, construction and move-in phases of the Village Hall remodeling effort, closing below budget.

**Customer Service:** Implemented performance standards, driving a 22% reduction in service response times in year one.

**Education:** Developed the strategy for an education partnership between Village, County and School Board.

#### ASSUMPTION OF PUBLIC WORKS FUNCTIONS FROM LEE COUNTY

Hired as the fifth employee in a newly incorporated Village, I was tasked with leading Estero's assumption of Public Works functions from Lee County. The Village already provided building permitting, code compliance, plan review, and finance. However, Estero wanted to provide additional services such as road maintenance, landscaping, and water quality monitoring in order to improve the quality of life for the growing Village.

- ☑ In order to provide background on the desired and achieved service level, I reviewed the goals and objectives as stated in the incorporation proposal from the summer of 2014, as well as the Public Works proposal from our County.
- ☑ The review showed that we were not receiving sufficient service, so I created our own Village Public Works Department to meet this standard of care.
- ☑ We contracted with eight private providers to deliver municipal services, as well as one part-time employee.

**Impact:** Through this process, we were able to reduce annual maintenance costs from \$2.6MM to \$300K; schedule \$70MM+ in CIP projects over 7-years (\$40MM+ coming from outside funding sources), and implement performance metrics (which have shown a 90% improvement in response time in two years of operations).

#### HURRICANE IRMA

As Hurricane Irma approached, and ultimately provided a direct hit to Estero, I was tasked with leading our preparation, response, and the subsequent mitigation efforts with a Public Works and Communications team that consisted of two part-time employees.

- ☑ Enacted operations and communications response plan, including partnering with our County, contracting with local providers, and activating part-time staff to work remotely (the majority of the staff was forced to leave the area).
- ☑ This amalgamation response team provided road clearance, stormwater management, emergency services, internal communications, and public relations.
- ☑ The Village sustained damage on, and blockage of, all of our arterial roads and a majority of our local roads. We completed our cleanup efforts faster than neighbor municipalities while providing individualized responses to all resident inquiries (via an online portal I designed and built).
- ☑ Managed negotiations and provider contracts for a successful FEMA reimbursement process.
- ☑ My leadership included overseeing the development of our contract negotiation strategy and the creation and management of our joint employee/consultant reimbursement team. Coordinated public relations throughout the process, providing Village-specific updates to residents in real-time.

**Impact:** The Village encountered \$4MM of damages in total. Through my leadership, we limited our upfront costs to \$250K and recovered 85%+ of our total costs.

### CHANGING THE CLERK, BUILDING, & PERMITTING OFFICE PROCESSES

With lawsuits being filed against neighbor cities in consecutive days regarding compliance with the American's with Disabilities Act (ADA), I was tasked with reworking all facets of our Village operations to mitigate the substantial litigation risk.

- ☑ Led the redesigning of the Village of Estero's website and the re-engineering of our meeting streaming, public records request, agenda and minutes preparation, building permit review and code compliance processes for ADA compliance.
- ☑ Achieved through coordinating wholesale changes to our Clerk, Information Technology, Planning, Building, Code Compliance, Public Works and Administration divisions.

**Impact:** By my actions, we took the ADA-compliance threat and leveraged it into an opportunity to further embrace transparency, access, and accountability. Outcomes include:

- ✓ The Village has not been implicated in any ADA-related litigation, as all documents made available on our website, as well as all of those provided to the public via email, are now fully ADA-compliant.
- ✓ We are nearing the launch of a new one-stop resident portal, which will allow our residents to submit requests for assistance, from any Village department, through one form.
- ✓ Building permit applications, requests for assistance with potholes, records requests, or any other Village-related issue will be taken by one conditional form and routed to the appropriate internal division.
- ✓ All public safety, land use, public works, emergency response, geographic, and education data will be provided in one interactive, online public GIS map, with an accompanying open data portal.

### PRIVATE EXPERIENCE

**FOUNDER AND CHIEF EXECUTIVE OFFICER**  
The SAT Academy of Southwest Florida

March 2018 – Present

Created this company to serve a need for affordable sat prep in this region, as test prep can be a major obstacle to high schoolers being able to go to college.

**Legal/Administrative:** Created legal formation documents, web presence, grading algorithm and report, and marketing materials.

**Customer Engagement:** Grew customer base to 40+ clients in year one, driven almost exclusively by referrals of satisfied customers.

### NONPROFIT EXPERIENCE

**EXECUTIVE DIRECTOR**  
Greater Syracuse Project

September 2014 - July 2016

Hired by department administrators to assist with the development of a nonprofit, which was being co-founded by university professors (former practitioners). Following the departure of the executive director within the first month of my start, I assumed this role and continued to work with these administrators to develop this nonprofit. This nonprofit leveraged student and faculty talent to improve the skillset of local nonprofit leaders. My background in IT, finance, and public administration, as well as my self-starter mentality, were viewed as major strengths for starting this nonprofit.

**Strategic:** Built a neighborhood system whereby students systematically upgraded the technical capacity of nonprofits. Instituted a mechanism for resource sharing, allowing local nonprofits to reduce administrative burden and costs.

**Human Resources:** Managed the leadership team, student volunteers, nonprofit partnerships and 18 long-term consulting projects.

### LEADERSHIP RECOGNITION

Following the departure of the Executive Director two weeks into my term, I was tasked with assuming the Executive Director role and developing all operational and communication facets of the newly formed 501(c)(3).

- ☑ Developed partnerships with local nonprofits, recruited volunteer community consultants via networking and advocacy, managed our grant application process, coordinated the creation of an online portal, and developed organizational operating procedures.
- ☑ Given the organization had formed only weeks before I joined, all facets of strategic and daily operations had to be created.

**Impact:** Coordinated 18 long-term consulting projects, systematically upgrading the organizational capacity of local nonprofits. Further, our organization created a platform for resource sharing, allowing nonprofits to reduce administrative burden and expand impact by cross-pollinating services. Recognized for my leadership efforts with the Albert B Merrill Award, an annual honor bestowed on the individual who best demonstrates effective use of public-private partnerships for the public good.



**EDUCATION****Syracuse University, Syracuse, New York 2010 - 2016****Master of Public Administration (MPA)**

Concentration: State and Local Government Financial Analysis and Management.

Coursework: Public Administration, Public Budgeting, Tax Policy and Politics, State and Local Finance.

**Master of Business Administration (MBA)**

Concentration: Finance

Coursework: Data Analytics, Financial Modeling, Human Resources, Legal and Ethical Aspects of Management.

**Certificate of Advanced Study (CAS)**

Concentration: Health Services Management and Policy. Coursework: Health Services Management, Changing American Health Care System, Behavior in Organizations.

**Bachelor of Science (BS)**

Majors: Accounting, Finance, Information Management and Technology. Coursework: Fast Cities (Rise and Fall), Financial and Cost Accounting, Audit, Database Management Systems.

**Bachelor of Arts (BA)**

Major: Economics. Coursework: Public Economics, Labor Economics, Critical Research and Technical Writing, Public Speaking.

**PROFESSIONAL DEVELOPMENT**

ICMA (International City and County Manager Association) National Conference (2017/2018)

FCCMA (Florida City and County Manager Association) State Conference (2018/2019)

FGCU Ethics Training Courses (2016, 2017, 2018, 2019)

ICMA Emerging Leaders Development Program (Class of 2021)

**PROFESSIONAL AFFILIATIONS – BOARD APPOINTMENTS – MEMBERSHIPS**

ICMA, FCCMA, Estero Chamber of Commerce Member

**HONORS - AWARDS**

Albert Merrill Public-Private Partnership Award (Maxwell College, Syracuse University)

**LANGUAGES**

English: Fully Proficient (Native)

Spanish: Reading Proficient, Basic Speaking and Listening (Non-Native)

**VOLUNTEER ACTIVITIES / CIVIC CONTRIBUTIONS**Founder and CEO, SAT Academy of Southwest Florida, Fort Myers, FL, 03/2018-Present  
- Provide low cost SAT tutoring to local kids to assist them with getting into college and receiving scholarships.**SPEAKING ENGAGEMENTS AND PRESENTATIONS**

Speaker, Developing a Public Works department, American Public Works Association, Fort Myers, FL, 01/2018

Speaker, Update on Estero Village strategy, Estero Chamber of Commerce, Estero, FL, 06/2018

Presenter, Estero Nonprofit Night, Estero Chamber of Commerce, 04/2017, 04/2018, 04/2019

**PUBLICATIONS**

Estero Life Magazine, Each month since June of 2018

**COMPREHENSIVE LIST OF SKILLS AND COMPETENCIES**

Accounting	Public Liabilities	Legal and Administrative	Volunteer Management
ADA Liability	User Engagement	Website Development	Public Records Response
Annexation	Technology	Local Government Finance	Public Safety
Basic Spanish	Database Management	Local Government Law	Public Speaking
Bidding Processes	Disaster Response	Maintenance Cost	Public Works
Branding	Ecological Sustainability	Management	Public-Private Partnerships
Budget Process	Economic Development	Marketing Campaigns	Purchasing
Business Administration	Emergency Communications	Marketing Material	Recruiting/Onboarding
Business Creation	Emerging Technology	Development	Reengineering Review
Capital Improvement	Employee Wellness/Safety	Media Relations	Reserves Creation
Projects	Expense Minimization	Municipal Contracts	Resource Sharing
Cash Flow	FEMA	Municipal Courts	Retirement Plans
Citizen Engagement	Financial Modeling	Municipal Utilities	RFP/RFQ
City Ordinances	Financial Policy	Nonprofit Leadership	Risk Management
Clean Water Management	Fire Districts	Open-Source Software	Sales Tax Revenue
Code Enforcement	Grant Administration	Utilization	Scope of Work Development
Community Development	Grant Applications	Organizational Behavior	Service Agreements
Community Expectations	Highway Beautification	Organizational Nimbleness	Shared Services
Community Relations	Human Resources	Partner Agency Relations	Site Plan Review
Compensation Plans	Information Technology	Partnerships/Alliances	Special Events
Contract Negotiation	Intergovernmental	Pension Liabilities	Staff Motivation/Training
Contract Services	Agreements	Performance Management	Stakeholder Advocacy
Cost Analysis	Internet-of-Things	Permit Reviews	State Legislative Affairs
Cost Reduction	Integration	Planning & Zoning	Strategic Planning
Council Relations	Interpersonal Issue	Principled Leadership	Sustainability Initiatives
Critical Research	Management	Program Evaluation	Tax Allocation
Data-Driven Management	Labor Economics	Public Administration	Tax Policy
Tourism	Land Purchases	Public Communications	Technical Writing
Legislative Relations	Leadership	Public Finance	Third Party Funding

**STEVEN S. DAVIS, MPA CPM**  
228 Chippingwood Circle Pooler, Georgia 31322  
Cell: (678) 215-2569  
repstevedavis@gmail.com

---

### **SKILLS**

Innovative thinker with broad-based expertise in State and Local Government Operations, Public Policy, Intergovernmental Relations, Transportation, Public Speaking, Nonprofit Management, Strategic Planning, Real Estate markets, Finance, Business Development, and Construction. Proven ability to quickly and thoroughly analyze key business drivers and develop strategies to grow and manage bottom line. Self and team motivator with strong leadership qualities.

---

### **EXPERIENCE**

**Effingham County Board of Commissioners**  
*County Administrator*

**Sep 2017 – Oct 2018**

- 405+FTE with 26 Department Heads
- \$29 Million General Fund FY2019
- \$56 Million Special Fund and Capital Budget FY2019
- \$85 Million Total funds Managed FY2019
- \$4.4 Billion Tax Digest
- Manage all administrative affairs of County
- Implement policies of the Board in accordance with state and federal laws
- Responsible for all finances and financial planning, including preparation of annual budget
- Oversee and manage all personnel decisions of the County
- Act as liaison between the Board, employees, other state and local officials, and the community
- Prepare agenda items and make all staff recommendations
- Prepare and distribute reports as directed by the Board
- Host Department Head and Divisional Meetings
- Manage public relations, including on camera interviews and press requests
- Major Events: Hurricane Irma, Winter Storm Grayson, Hurricane Floyd, and Hurricane Michael
- Re-organized County departments, including consolidation and privatizing
- Negotiated new Solid Waste Contract
- Negotiated new Food Service Contract for County Prison and Jail
- Operationalized paperless billing and auto-pay for water billing
- Operationalized credit card and online payment options for Development Services
- Managed completion of \$7 Million phase of sports complex
- Managed completion of \$1 Million Josh Reddick Stadium
- Managed completion of multiple local transportation projects
- Managed PE and ROW acquisition for 2 major GDOT Projects

**American Concrete Paving Association/Portland Cement Association**  
*Executive Director - Georgia*

**March 2013 – Sept 2017**

- Manage nonprofit trade association operations
- Review and monitor Georgia Legislative actions
- National Legislative Task Force evaluating and responding to potential legislation
- Increase market share for concrete pavement and other cement products

- Develop strong business relationships and sustain essential contact with contractors, suppliers, owners and engineers.
- Coordinate with promotion partners and collaborate with pertinent professional associations to advance Concrete Pavements.
- Planning, developing and conducting educational workshops, seminars, and project visits
- Responding to inquiries for technical information and assistance
- Maintaining effective relationships with public and private professional organizations
- Create effective quantitative quarterly reports on concrete and cement usage
- Maintain communication with Board of Directors with monthly updates on promotions
- Maintain communication with national group and staff
- Manage central office administration staff and ensure strict budget compliance
- Manage association membership and fundraising activities

**Georgia House of Representatives**

**Elected November 2004 – Jan 2013**

*State Representative*

- Elected to 4 terms
- Chairman of Information and Audits Committee
- Vice Chair of State Planning and Community Affairs Committee
- Member of Transportation Committee and Chair of Air Transportation Sub committee.
- Member of Insurance Committee and Vice Chair of Health Insurance Sub committee.
- Member of Appropriations Committee.
- Member of State Institutions and Property Committee and Chair of Inmate Issues Sub committee.
- Deputy Majority Whip.
- Key legislation passed: transportation distribution, state infrastructure bank, sex offender, flexible High School graduation, mandated college articulation, insurance prompt pay
- Transportation bill that changed the division of the transportation funding (\$2 Billion a year) between the Congressional districts.
- In addition to the duties already mentioned I must maintain a host of constituent services and speaking engagements to fulfill my duties of office

**Cape Real Estate Sales and Trading**

**Feb 2009 – March 2013**

*CEO / Broker*

- Build and operate small Real Estate Firm with 29 agents. Maintain all required data and contracts from all agents.
- Monitoring market trends, industry-related information, educational articles and research data to educate clients by outlining the best tools for the performance of their assets.
- Building and maintaining mutually strong relationships with key community leaders, business owners, realtors as well as the brokerage community.
- Representing buyers, sellers, landlords and tenants associated with retail, commercial and industrial properties as well as raw and developed land sales.
- Utilizing various forms of technology, my extensive knowledge of the market and strong personal networks to compile marketing packages and investment analysis for my clients looking to purchase commercial and industrial land as well as leasing of office space.
- Ensure all licensing of firm and agents is maintained. Taxes and continuing education.

**MME Construction Group**

**Feb 2008 – Feb 2009**

*Director of Sales and Marketing*

- Planning and implementing new business activities to meet company targets.
- Focus on growth and profitability of commercial activities.
- Prepare business strategic plan identifying potential markets and customers.
- Monitor correction plans and actions according to customer responses to satisfaction surveys.

- Independent Contractor for real estate sales including commercial and residential properties.
  - Consistently met sales goals by which all leads and sales were self generated.
  - Focused predominantly on residential and commercial sales with a few large tract land sales.
  - Consistently sold over \$2 million annually and 2005 was over \$8 million in sales.
- 

## **EDUCATION**

**University of Georgia, Certified Public Manager**  
Carl Vinson Institute of Government

**Arkansas State University, Masters of Public Administration**  
Phi Alpha Alpha member, the National Honor Society for Public Affairs and Administration

**Troy University, Bachelor of Political Science in Public Administration, Business Minor**

**Morrow High School, College Preparatory Diploma**

---

## **MAJOR SPEAKING ENGAGEMENTS**

Georgia Property Rights Coalition  
American Dream Coalition National Conference  
National Association of Insurance Agents  
Veterans Day Ceremonies  
Council for Quality Growth  
Henry County Board of Education  
Leadership Henry  
Eagle Scout Court of Honor  
Numerous school events

State Bar of Georgia  
American Cancer Society  
Georgia Farm Bureau  
Rotary Club  
Chamber of Commerce  
Georgia Skills USA  
Youth Leadership Henry  
Henry County Moose Lodge  
Numerous political events

---

## **AFFILIATED ORGANIZATIONS**

American Concrete Pavement Association  
Concrete Pavement Tech Center  
Georgia Airport Association  
Georgia Public Policy Foundation  
Georgia Council for Quality Growth

Portland Cement Association  
Transportation Research Board  
Georgia Engineering Association  
Carl Vinson Institute for Government  
Association of County Commissioners GA

---

## **AREAS OF EXPERTISE INCLUDE:**

- Leading & Developing Teams
- Use of Technology
- Public Speaking
- Developing New Business
- Positive Client Relationship
- Negotiating & Closing Deals
- Consultative Sales Approach
- Key Account Management
- Managing Budgets
- Strategic Planning
- Solutions-Oriented Selling

## **RICHARD A. DOUGLAS, AICP, ICMA-CM**

2508 South Carpenter Drive  
Covington, Virginia 24426  
919-464-4378  
raefordcitymanager@yahoo.com

### ***PROFESSIONAL PHILOSOPHY***

To provide quality community services utilizing a results-oriented management style that emphasizes the principles of honesty, initiative, creativity, and customer service.

### ***PROFESSIONAL EXPERIENCE***

City Manager, Covington, Virginia, March 2016 to February 2019

Responsible for overall administration of an independent city (\$24 million operating budget excluding school funding), with municipal services such as police, EMS, public works, sanitation/landfill, water, wastewater, development services, parks and recreation, finance, and administration, and joint services such as Sheriff/jail/courts, social services, health services, library, and economic development.

Accomplishments include the following:

- Improved regional cooperation with neighboring county governments, including the adoption of a joint economic development revenue sharing agreement and a joint comprehensive planning process with Alleghany County; the development of a Drone Zone, a regional economic development project funded in part with a Appalachian Regional Commission grant and involving the redevelopment of a former school property; and a long-term landfill use agreement with Bath County that provided financial stability for the City's landfill operation
- Established a city emergency medical services department to include the use of 24/7 paid EMS staff, which greatly improved response time, reliability, and level of care, while maintaining a significant role for the volunteer Covington Rescue Squad and its declining membership
- Based in part on an external assessment of the Police Department, undertook measures to improve departmental operations and public confidence, to include completing the state law enforcement accreditation review process, implementation of more community policing measures; and increasing drug enforcement measures, such as acquiring first K-9 in several years
- Received approximately \$3 million in state funding to resurface most of the major streets in the city and to complete a downtown streetscape project that had been delayed for several years; coordinated with city's engineer to develop a street paving prioritization list, and paved at least four streets each of the past three years

- Completed 14-year expansion of city's landfill, replaced all landfill equipment and scales, and reorganized staff, to improve operational efficiency, obtain and maintain state permit compliance, and increase trust with state regulatory personnel; established a separate solid waste enterprise fund to ensure sufficient revenues for current and future landfill/sanitation obligations
- Received state grant funding/zero interest loan to upgrade all wastewater lift stations, to ensure reliability and permit compliance, negotiated wastewater consent order with state regulatory personnel for the construction of a wastewater equalization basin at the wastewater treatment plant and received state funding for the project; made substantial improvements to the city's water plant, restarted a hydrant flushing program, and inspected all water tanks, which had not been completed in several years
- Established a development services department (formerly known as the building inspector's office) and increased emphasis on planning, code enforcement, and economic development; implemented a minimum housing prioritization list and removed or improved several residential structures over the past three years

Town Manager, Erwin, North Carolina, July 2013 to October 2015

Responsible for overall administration of municipal government (\$3 million operating budget), including police, public works, planning and code enforcement, parks and recreation, library, finance, and administration, with an emphasis on planning and economic development. Accomplishments include the following:

- Worked with economic development consultant and state and local economic development professionals to identify redevelopment strategies for 57-acre former Erwin Mills denim manufacturing property
- Removed town from nine-year probationary status with National Floodplain Insurance Program and addressed major stormwater management issues
- Updated 15-year old land use plan and completed several revisions to town's zoning ordinance
- Worked to improve attractiveness and economic viability of downtown area, including streetscape and sidewalk planning, completion of feasibility study to relocate historic depot to downtown, completion of historic district nomination application, and park improvements (PARTF grant)

Town Manager, Selma, North Carolina, October 2008 to July 2013

Responsible for overall administration of municipal government (\$17 million operating budget), including police, fire, electric, public works, planning and code enforcement, water and wastewater, parks and recreation, library, finance, and administration. Accomplishments include the following:



- Expanded or relocated police station, fire station, gymnasium and library facilities to better serve residents and fulfill department missions, utilizing low interest financing and \$300,000 in grant funding
- Expanded planning and code enforcement efforts, including the preparation of the first land use plan in 30 years, preparation of master water and wastewater plans, revisions to zoning and subdivision ordinances, the abatement of nuisance properties, including the removal of over 500 junk vehicles, and the implementation of a targeted service area program to address specific neighborhood needs
- Achieved certified industrial site designation through the NC Department of Commerce for two industrial sites, including a 150+ acre dual rail-served site
- Completed numerous improvements to the water and wastewater systems, including wastewater lift station and line improvements funded in part with a \$550,000 grant, and automation of the water and wastewater systems (SCADA)
- Reduced the town's ISO insurance rating, decreased fire department response time, and improved overall fire services through such efforts as the initial implementation of a 24-hour fire station staffing plan, implementation of an equipment replacement schedule, expansion of station space, and vehicle and equipment replacement
- Improved flexibility for electric customers through the establishment of the first electric pre-pay system in the state

City Manager, Raeford, North Carolina, October 2004 to October 2008

Responsible for overall administration of municipal government (\$7 million operating budget), including police, fire, public works, planning and code enforcement, water and wastewater, finance, and administration. Accomplishments include the following:

- Completion of \$2.6 million comprehensive downtown streetscape project
- Significant improvements to the wastewater treatment plant and strengthening of industrial pretreatment program that led to consistent NPDES permit compliance and improved relationship with NC DENR
- A water system improvements project, with over \$700,000 in grant funding, that boosted the city's domestic capacity and enabled expansion for a large local industry

County Administrator, Long County Board of Commissioners, Ludowici, Georgia, April 2000 to September 2004

Served as first county administrator for rural but fast growing Southeast Georgia county. Accomplishments include the following:

- Preparation of the county's first subdivision ordinance and other land use regulations
- Successful transition to county-wide curbside garbage collection and establishment of two recycling centers
- Development of regional emergency 911 system
- Expansion of county recreation park
- Establishment of county industrial park (\$465,000 state economic development grant)

Planner, Coastal Georgia Regional Development Center, Brunswick, Georgia, August 1998 to March 2000

Natural Resources Planner, Maryland Department of Natural Resources, Annapolis, Maryland, January 1996 to July 1998

Analyst/Research Assistant, ICF Kaiser, Fairfax, Virginia, February 1992 to November 1995

### ***EDUCATION***

University of Virginia, Master of Planning, May 1995

James Madison University, BS, Public Administration and Political Science, May 1991

Public Executive Leadership Academy, University of North Carolina-Chapel Hill, August 2014

### ***PROFESSIONAL MEMBERSHIPS/ORGANIZATIONS***

American Institute of Certified Planners (AICP), #012068

International City/County Management Association, Credentialed Manager (ICMA-CM)

American Planning Association

Virginia Local Government Management Association

North Carolina League of Municipalities, Planning & Environment Legislative Action Committee (former member)

Alleghany Highlands Economic Development Corporation, Executive Committee (2016-2019)

Roanoke Regional Partnership, Executive Committee (2016-2019)

Alleghany Highlands Chamber of Commerce, Board of Directors (2016-2019)

North Carolina Eastern Municipal Power Agency, Board of Commissioners (2008-2013)

Smithfield-Selma Chamber of Commerce, Board of Directors, Economic Development and Public Policy Committees (2008-2013)

Covington-Hot Springs Rotary Club (2016-2019)  
 Alleghany Highlands Kiwanis Club (2016-2019)  
 Granbery Memorial United Methodist Church Choir (2016-2019)  
 Dunn-Erwin Rotary Club (2013-2015)  
 Rotary Club of Central Johnston County (Paul Harris Fellow, 2008-2013)  
 Selma Lions Club (2008-2013)  
 Raeford Kiwanis Club (2004-2008)  
 Fort Bragg Regional Land Use Advisory Committee, Secretary (2006-2008)  
 Coastal Georgia RC&D Council, 2002 Member of the Year

**REFERENCES**

Allan Tucker	Covington City Council	540-969-8457
Theresa Fontana	Former Covington City Attorney	561-503-6967
Temple Kessinger	Former Covington Mayor	540-962-5295
Mary Fant Donnan	Alleghany Foundation	540-962-0970
Marla Akridge	Alleghany Highlands EDC	540-968-2325
Billy Turnage	Erwin Board of Commissioners	910-514-0753
Jim Dougherty	Fort Bragg Regional Land Use Advisory Commission	910-583-1233
John Grey	The Wooten Company	336-626-5322
Charles Bowen	Selma Police Chief (retired)	919-796-8333



# RANDALL DOWLING

770-324-5160 | [Dowlingrandall@gmail.com](mailto:Dowlingrandall@gmail.com)  
P.O. Box 1224 | Pine Mountain, Georgia 31822

---

July 14, 2019

City of Winter Springs, FL  
ATTN: Casey Howard  
1126 East SR 434  
Winter Springs, FL 32708

**Re: City Manager Position**

Dear Casey Howard:

The City of Winter Springs is seeking a seasoned city manager that has a significant amount of public administration education and local government management experience. I possess those unique qualifications. I have earned a Bachelor of Science in Public Administration degree and a Master of Public Administration degree. I am also continuing my professional education through on-line programs. In addition to a solid educational foundation, I have significant experience managing all types of local government departments including community development, finance, public works, information technology, solid waste, utilities, parks and recreation, senior services, emergency services, human resources, and outsourced services under contractual arrangements in high growth areas, resort communities, and primarily in Florida and Georgia communities. Specifically, I have experience in budget preparation, implementation, and control, mentoring department heads and obtaining resources for their use, implementing policy initiatives, conducting strategic planning in the areas of parks and recreation, transportation, and solid waste, writing successful federal and state grants, preparing for and responding to natural disasters, and keeping everyone informed of major activities through a unique Program of Work document. I also have experience managing many successful capital improvement projects such as park improvements, road/drainage/sidewalk improvements, NextGen 911 systems, and technology improvements. I continuously look for ways to improve government operations to gain efficiencies and cost savings. Externally, I have been a part of the fabric of each community I have served by actively participating in many civic events and organizations such as the local Chambers of Commerce.

Currently, as county manager of Harris County, Georgia, a growing suburban county one hour southwest of the Atlanta international airport and home to one of Georgia's premier attractions, Callaway Gardens, I prepare and implement the \$40M annual budget, supervise 12 department heads and 381 full-time and part-time employees, and manage the day-to-day operations of the local government. During my tenure, my management team and I have constructed numerous capital improvement projects including a new library, park and recreation improvements, road improvements, and 911 improvements, made many operational enhancements to increase efficiencies and cost savings, and created a positive work environment.

I am seeking this exceptional opportunity due to Winter Springs high quality-of-life, great location, and desired mix of public services. Please review my resume to determine if I have the desired qualifications Winter Springs is seeking to give the organization a fresh perspective and to take the city to the next level of success. Thank you for your consideration.

*Randall Dowling*

# RANDALL DOWLING

770-324-5160 | [Dowlingrandall@gmail.com](mailto:Dowlingrandall@gmail.com)  
P.O. Box 1224 | Pine Mountain, Georgia 31822

## Career Summary

**32 years of local government management experience. Academic credentials include MPA and BSPA degrees and continuing education.**

## Skills

- Budget preparation and control
- Highly organized
- Successful grant writing
- Strategic planning
- Employee accountability
- Team approach to decision making
- Complex problem solving
- On time/on budget project management
- Proactive and participatory leadership
- Results oriented
- Effective public speaking
- Ability to cut through red tape to get things done

## Professional Experience

### County Manager

Harris County (40,000 population) | Hamilton, Georgia

*2016 to Present*

- Prepare, implement, and monitor the county's \$40M annual budget.
- Oversee the day-to-day operations of the county government, supervise 12 department directors and 381 full-time and part-time employees, and coordinate the activities of various elected officials and other public agencies.
- Implement Board policies.
- Keep the elected officials, staff, and public informed of major county activities through a comprehensive and frequently updated Program of Work document that details the status of each major project and contains several local economic indicators such as monthly sales tax collections, solid waste tonnage collections, and residential building permits issued.
- Engaged a new solid waste contractor through a competitive bidding process to transport and dispose of the county's collected solid waste and saved over \$250,000 per year or \$1M over the life of the contract.
- Managed many successful capital improvement projects including a new \$5.1M library, NextGen 911 system, road and bridge improvements, park and recreation improvements, airport improvements, industrial park improvements, and upgraded 8,500 water meters to AMR technology.
- Prepared a SPLOST continuation plan that resulted in a successful referendum vote during 2018.
- Updated the county's comprehensive master plan, airport master plan, and five-year capital improvement program to guide the county's future growth.
- Wrote, was awarded, and successfully administered over \$1M in competitive federal and state grants for recreational improvements, industrial park improvements, and economic development.
- Increased interest earnings from \$40,376 in FYE 2017 to over \$200,000 in FYE 2019, a 395% increase and increased the General Fund unrestricted fund balance by 20% from 2017 to 2018.
- Developed bid and RFP specifications for a variety of products and services.
- Resolved citizen complaints and responded to media inquiries.
- Strategically identified short and long-range opportunities that would benefit the county.

# RANDALL DOWLING

---

## **County Manager**

**Dawson County** (24,000 population) | Dawsonville, Georgia

*(short term contract) 2016*

- Monitored the county's \$46M annual budget.
- Oversaw the day-to-day operations of the county government, supervised 8 department directors and 300 full-time and part-time employees, and coordinated the activities of various elected officials and other public agencies.
- Implemented Board policies.
- Kept the elected officials, staff, and public informed of major county activities through a comprehensive and frequently updated Program of Work document that details the status of each major project and contains several local economic indicators such as monthly sales tax collections, solid waste tonnage collections, and residential building permits issued.
- Managed several capital improvement projects including road improvements, park and recreation improvements, courthouse improvements, and vehicle replacements.
- Outsourced EMS billing to another private company to improve revenues and customer service.
- Conducted an employee satisfaction survey and as a result initiated an employee compensation study to determine new competitive pay rates.
- Conducted an auction of surplus county vehicles and equipment to dispose of unneeded assets, update the inventory listings for insurance purposes, and generate revenue.
- Developed bid and RFP specifications for a variety of products and services.
- Resolved citizen complaints and responded to media inquiries.
- Strategically identified short and long-range opportunities that would benefit the county.

## **County Manager**

**Barrow County** (71,000 population) | Winder, Georgia

*2013 to 2015*

- Prepared and monitored the county's \$75M annual budget.
- Oversaw the day-to-day operations of the county government, supervised 10 department directors and 576 full-time and part-time employees, and coordinated the activities of various elected officials and other public agencies.
- Implemented Board policies.
- Kept the elected officials, staff, and public informed of major county activities through a comprehensive and frequently updated Program of Work document that details the status of each major project and contains several local economic indicators such as monthly sales tax collections, solid waste tonnage collections, and residential building permits issued.
- Transitioned the county government from a traditional commission to a commission-manager form of government and improved the administrative framework that included a professional web site with e-government services, streamlined budget process and document, five-year capital improvement program, and hired many vacant department director positions.
- Lowered the property tax rate from 13.26 to 12.75 mills by reducing expenses, refinancing three bond issues, and creating a storm water utility.
- Conducted a Board initiated year-long process to outsource many county departments using a public-private partnership (P3) model to improve organizational efficiencies and achieve cost savings. Selected consultant guaranteed \$4M in savings over a five-year contract period. Board voted not to implement proposal. Outsourced services on a case-by-case basis including EMS billing, lawn care, and fleet management.
- Upgraded the county-wide 911 public safety radio system from a VHF system to a modern 700 megahertz system for better radio coverage.

# RANDALL DOWLING

---

## Barrow County, Georgia (continued)

- Supervised many capital improvement projects including road improvements, utility improvements, and prepared strategic plans.
- Developed bid and RFP specifications for a variety of products and services.
- Resolved citizen complaints and responded to media inquiries.
- Strategically identified short and long-range opportunities that would benefit the county.

## **County Administrator**

### Gordon County (60,000 population) | Calhoun, Georgia

2002 to 2013

- Prepared and monitored the county's \$48M annual budget.
- Oversaw the day-to-day operations of the county government, supervised 13 department directors and 400 full-time and part-time employees, and coordinated the activities of various elected officials and other public agencies.
- Implemented Board policies.
- Kept the elected officials, staff, and public informed of major county activities through a comprehensive and frequently updated Program of Work document that details the status of each major project and contains several local economic indicators such as monthly sales tax collections, solid waste tonnage collections, and residential building permits issued.
- Outsourced the management of the county's 600 acre MSW landfill which resulted in significantly higher waste tonnage, higher revenue stream, and lower county expenses. Also outsourced inmate medical, inmate food service, and county-wide lawn care to achieve cost savings.
- Prepared two SPLOST continuation plans that resulted in successful referendum votes during 2005 and 2011.
- Increased the General Fund unrestricted fund balance by 203% from \$5.3M in 2003 to \$16.1M in 2012 through various means that resulted in healthy cash reserves and an excellent AA bond rating. For 2012, the General Fund unrestricted fund balance was 59.1% of total General Fund expenditures.
- Supervised the design and successful completion of many major capital improvement projects including a \$30M jail and Sheriff's Office, \$11M regional recreation complex, \$3M fire station with equipment, \$3M county-wide 911 public safety VHF simulcast radio system, \$11M road and bridge improvements, \$4M DFACS facility using 100% state funds, Boys & Girls Club and other social service facilities using CDBG funds, \$2.5M agricultural service center to house all federal, state, and local agricultural agencies under one roof, and two civil war historic sites using federal funds.
- Prepared and implemented numerous strategic plans to guide the county's future growth including a comprehensive master plan 2007-2027, unified land development code, transportation plan, solid waste management plan, parks and recreation master plan, and two historic overlay districts.
- Developed and fully implemented a county-wide compensation plan to fairly compensate all employees based on market rates.
- Had the county designated as a "Storm Ready" and "Camera Ready" community and received several GFOA awards for financial reporting.
- Developed bid and RFP specifications for a variety of products and services.
- Resolved citizen complaints and responded to media inquiries.
- Strategically identified short and long-range opportunities that would benefit the county.



# RANDALL DOWLING

---

## **County Administrator**

**Lee County** (28,000 population) | Leesburg, Georgia

*1996 to 2002*

- Prepared and monitored the county's \$24M annual budget.
- Oversaw the day-to-day operations of the county government, supervised 8 department directors and 225 full-time and part-time employees, and coordinated the activities of various elected officials and other public agencies.
- Implemented Board policies.
- Kept the elected officials, staff, and public informed of major county activities through a comprehensive and frequently updated Program of Work document that details the status of each major project and contains several local economic indicators such as monthly sales tax collections, solid waste tonnage collections, and residential building permits issued.
- Supervised the design and successful completion of numerous capital improvement projects including a jail/Sheriff's Office/911 Center, public works facilities, senior citizens center, health department, administration building, three fire/EMS stations, historic courthouse renovations, park and recreation complexes, and road and bridge improvements.
- Prepared many strategic plans including a fire insurance rating reduction study which resulted in a reduction from an ISO class 9 to a class 6 (typical homeowner saved about 30% in annual fire insurance premiums), service delivery strategy plan delineating the service delivery responsibilities of the county and each city within the county to avoid duplication of services, county-wide storm water management plan, two SPLOST continuation plans, and a liquor-by-the-drink plan which resulted in successful referendum votes.
- Wrote, was awarded, and successfully managed over \$11M in competitive federal and state grants for park and recreation improvements, hazard mitigations, and historic preservation projects using CDBGs, FEMA grants, and Land & Water Conservation Fund grants.
- Recruited new businesses to the county including a Wal-Mart Super Center and other major retailers using various incentives that resulted in additional sales taxes and property taxes as well as employment opportunities.
- Developed bid and RFP specifications for a variety of products and services.
- Resolved citizen complaints and responded to media inquiries.

## **County Manager**

**Berrien County** (16,000 population) | Nashville, Georgia

*1993 to 1996*

## **Assistant to County Administrator**

**Indian River County** (100,000 population) | Vero Beach, Florida

*1990 to 1993*

## **Assistant to City Manager**

**City of Homestead** (25,000 population) | Homestead, Florida

*1987 to 1990*

## **Intern, City Manager's Office**

**City of Rockwall** (10,000 population) | Rockwall, Texas

*1986 to 1987*

# RANDALL DOWLING

---

## Education

### Continuing Education

Valdosta State University | Valdosta, Georgia

*2015 to Present*

### Master of Public Administration

University of North Texas | Denton, Texas

*August 1987*

### Bachelor of Science in Public Administration

University of Arkansas | Fayetteville, Arkansas

*May 1985*

## Professional Associations

Member, International City/County Management Association

*Since 1987*

Member, Georgia City/County Management Association

*Since 1994*

Member, Georgia Association of County Managers & Administrators

*Since 1994*

## Community Activities

Board of Directors, Harris County Chamber of Commerce

*2017 to Present*

Board of Directors, Gordon County Chamber of Commerce

*2002 to 2007*

# JACOB ELLIS

3963 E Esplanade Ave • Gilbert, AZ 85297 • Phone (480) 300 2783 • Email [jacobeellis79@gmail.com](mailto:jacobeellis79@gmail.com)

## EDUCATION

- Juris Doctor - Cleveland-Marshall College of Law** Cleveland, OH
- Dean's List, fall 2005 & spring 2006
  - CALI Excellence for the Future Award, Fall 2005
  - Academic law scholarship, 2004-2005
- Master of Public Administration - Cleveland State University** Cleveland, OH
- Levin College academic scholarship
- B.A., Political Science - Brigham Young University** Provo, UT
- Academic scholarship, spring-summer 2002 & 2003

## EXPERIENCE

- Town of Gilbert (Pop. 252,000)** Gilbert, AZ  
Deputy Town Manager 2017 – Present
- Day-to-day oversight and operational planning for: Development Services, Human Resources, Finance & Management, Economic Development, and Parks & Recreation.
  - *Economic development* projects: attraction of a *Deloitte* operations center bringing 2,500+ high wage jobs to the Town; negotiation of revenue producing P3s for *The Strand* - a 25 Acre surf, wake and watersports park, *Castle Golf* - a 4 acre family amusement park, and *Gilbert Memorial Park* - the Town's first cemetery; adoption of a 10-year Redevelopment Plan; lease agreements bringing Park University and the University of Arizona Nursing program to the Town's university building; and a 5-year tourism plan, in addition to development agreements for over 500,000 sf of restaurant, office, entertainment, hotel, and multifamily development projects on town owned land.
  - *Large scale, organization-wide special projects*: including development of performance metrics, large multi-year litigation, Council and Executive team retreats, new mission and organizational values.
  - *Capital improvement projects*: phase 1 & 2 (\$40M) of a 272 acre regional park, design for a \$14M main municipal office building renovation, \$15M renovation of an 8 field baseball complex, construction of an \$18M 600-stall parking garage; phase 1 (\$39M) of a 110 acre sports park, and more.
  - *Human resource initiatives*: including a new pay for performance compensation plan, creation of a leadership development program, streamlining the recruitment process reducing the average fill time from over 120 days to just 60 days, revamping the annual performance evaluation program, department restructuring to better serve employees, new employee handbook and culture guide, and improved the annual employee recognition program.
  - Development of the overall \$1 billion+ annual budget, coordination of day to day operations and performance; and development of quarterly dept. business plans.

Assistant to the Town Manager

2015 – 2017

- Coordinated major organizational projects under the direction of the Town Manager.
- Served as interim HR Director overseeing risk, benefits, employee relations, recruitments and organizational development for over 1,300 employees.
- Member of the executive team responsible for developing an \$950M+ annual budget.

**Cowichan Valley Regional District** (*Pop. 83,000*)

Duncan, B.C.

Deputy Chief Administrative Officer

2014 – 2015

- Senior policy advisor to the CAO and elected Board.
- Assisted the CAO to manage a wide range of high-level projects & initiatives and manage cross-departmental projects & initiatives.
- Coordinated inter-jurisdictional projects with other local governments and senior levels of government.
- Oversaw the annual production of business plans for 4 departments and 19 divisions.
- Managed all aspects of strategic planning for the organization, including plan updates, reporting, implementation and monitoring.
- Assisted with development of the annual budget, including presentations to the Board, analysis of tax impacts and supplemental budget reports.
- Served as an employer representative on the collective bargaining team.
- Acting Chief Administrative Officer in the absence of the CAO.

General Manager, Regional Services Department

2013 – 2014

- As a department head, provided high-level professional and technical assistance to the CAO and board.
- Carried out the duties of Corporate Planning Manager, plus oversaw a \$12.2M department budget and managed two divisions – Environmental Policy and Public Safety.
- Oversaw hiring, performance management, coaching, mentoring and dismissal of staff.

Manager, Corporate Planning (Office of the CAO)

2009 – 2013

- Directed and oversaw all aspects of the corporate strategic planning process, as well as supervise the development and submission of all annual department and division workplans.
- Developed policy proposals and coordinated major organizational projects under the direction of the CAO.
- Served as a member of the senior management team responsible for developing an \$80M+ annual budget, policy and program approval and providing overall organizational direction.

Coordinator of Policy, Research and Special Projects (Office of the CAO)

2007 – 2009

- Provided research and policy development support and advice to the Board and CAO on a wide range of topics spanning all departments and divisions
- Led and facilitated a collaborative, inclusive, corporate wide organizational restructuring process, including the formation and management of 10 staff teams totaling over 70 employees - the largest of its kind in over 40 years.
- Coordinated, led and implemented a range of specials project under the direction of the CAO.

**Municipality of North Cowichan**

North Cowichan, B.C.

Legal Researcher

2006

- Drafted bylaws, and advised the CAO, Mayor and Council on a wide range of municipal legal issues.
- Reviewed internal operating procedures and made recommendations on improving efficiency.

**Envision Utah**

Salt Lake City, UT

Assistant to the Executive Director

2003 – 2004

- Worked with key industry, civic, and government leaders on multiple regional projects.
- Oversaw planning and organization of major organizational events, coordinated meetings and set & produced agendas.
- Advised the Executive Director on a range of management and policy issues.

**Graham County Superior Court**

Safford, AZ

Judicial Intern

2003

- Conducted research, review presentencing reports, and drafted documents for the Presiding County Judge.
- Assisted the general public with pro se filings, and managed the forms law library.
- Evaluated and recommended judicial action on guardianship files.

**Utah State Legislature**

Salt Lake City, UT

Legislative Assistant

2003

- Worked as a legislative assistant to Senators Greg Bell and Curtis Bramble.
- Assisted with crafting bills, conducted research and gathered input from constituents, business and civic leaders.
- Managed communications, issues and inquiries from constituents, lobbyists, and other legislators.

**PROFESSIONAL MEMBERSHIPS**

- International City/County Managers Association (ICMA).
- Arizona City/County Managers Association (ACMA).

**PERSONAL SKILLS & FACTS**

- Trained mediator, experienced facilitator and dynamic public speaker.
- Proficient with Microsoft Office suite products.
- Training certificates in Speed of Trust, Situational Awareness, 7 Habits, 4 Disciplines of Execution, AAED Basic Economic Development, Gilbert Edge Academy (Lean Sigma).
- Excellent verbal, analytical, writing, listening and presentation skills.
- Favorite Management Books: *Dare to Lead*, *The Ideal Team Player*, *Leadership & Self Deception*, *Six Thinking Hats*, *The Halo Effect*, and *Servant Leadership in Action*.
- Married to my beautiful wife of 17 years with 5 kids who make it all worth it.

# Daniel Faulkner

## **Village Manager/Street Administrator/State Licensed Water Operator - Village of Lawrence**

Benton Harbor, MI 49022

danielfaulkner3\_ron@indeedemail.com

269.325.8165

Willing to relocate: Anywhere

## Work Experience

---

### **Village Manager/Street Administrator/State Licensed Water Operator**

Village of Lawrence

February 2014 to Present

More than 14 years of experience in municipal governments as well as 22 years in the private sector with expertise in the following areas:

Relevant Local Government Experience

Village Manager/Street Administrator/State Licensed Water Operator, Village of Lawrence

February 2014-Present

Lawrence is a village with a population of 996 covering six square miles. It is centrally located in the county of Van Buren, Michigan (population 76,258).

Duties and Responsibilities as Village Manager:

- Responsible for the Villages compliance with county, state and federal regulations such as annual budget, audit, consumer confidence report, Transportation Asset Management Commission with ADARS reporting drinking water and waste water monthly reports including annual lead and copper testing.
- Creation of 20-year water, waste water capital and financial improvement plans and the newly required 2018 water asset management plan.
- Street Administrator of the Villages roads and bridge inspections.
- Instrumental in working with the Van Buren County Intermediate School district, House Representative Aric Nesbitt, Senate leader Tonya Schuitmaker and the Michigan State Transportation committee to pass legislation to exempt trucks and busses from having to stop at abandoned rail crossings.
- Annual contract negotiations of police contract with the Van Buren County Sheriff's department. Oversight responsibilities for fire, roads, storm water drainage, water and waste water, parks, planning, zoning, finance, general services and personnel.
- Grants obtained: Rural Task Force major street fund 585k, Congestion Mitigation and Air Quality (CMAQ) 383k, West Alley Project Grant 350k and the Facade Improvement Grant 20k.
- Redevelopment Ready certified to implement practices to be certified as a Redevelopment Ready Community.

### **President and Chief Operating Officer, Education**

Wheels, Inc - Watervliet, MI

February 1991 to February 2014

Education on Wheels, Inc. is a library book company that specializes in the sale of library book to schools and public libraries. Located in Watervliet, Michigan. The company had three departments 35 employees.

Duties and Responsibilities as President and Chief Operating Officer:

- Prepared and submitted Request for Proposals (RFPs) for new school core library collections.
- Created and managed sales quotas for independent sales representatives.

### **Production Supervisor**

Zenith Data Systems - Saint Joseph, MI  
August 1987 to February 1991

Zenith Data Systems was a computer company that was an innovator and manufacturer of personal computers and laptops for the Federal government and public at large.

Duties and Responsibilities as Production Supervisor:

- Supervised an assembly line of 32 United Steel Workers Union employees.
- Negotiated employee United Steel Workers 3-year contract.

## Education

---

### **B.S**

Western Michigan University - Kalamazoo, MI

### **A.A, A.S in Business**

Kalamazoo Valley Community College - Kalamazoo, MI

## Skills

---

Real Estate, HUD, Property Management, Accounting, Management, Accounts Payable, Office Management, Microsoft Word, Customer Service, Excel, Word, Marketing

## Certifications/Licenses

---

**Michigan Department of Environmental Quality (MDEQ) S-3, D-3 Licensed Water Operator**

**State of Michigan Class A CDL License with Hazmat, Tanker, Doubles and Triples trailers**

**endorsements (Current).**

**truck and cold patch equipment (2013/2014).**

**Engaged in the ICMA Professional Development Certification Program (2017)**

**Michigan Association of Planning Certification (2016)**



**Michigan Economic Development Corporation (MEDC) Redevelopment Ready Communities Best**

**Practice Trained (2016)**

**Street Administrator and the State Licensed Water Operator for the Village of Lawrence**

**and challenging constituents. Additionally, I believe that my being a licensed water operator**

**Village Manager/Street Administrator/State Licensed Water Operator**

**State of Michigan trained and licensed to operate Front End Loader, Back Hoe, and Skid Steer**

**2016/2017**

**endorsements (Current)**

**truck and cold patch equipment (2013/2014)**

**Driver's License**

Groups

---

**Michigan Rural Water Association**

**AWWA Association**

**Lions Club International**

**ICCMA International City/County Management Association**

# Dylan Feik

108 Jutta Way • Windsor, CA • (801) 821-1734 • Dfeik8@gmail.com

## SUMMARY OF QUALIFICATIONS

- Performance-driven professional with 15 years of executive leadership and broad management skills developed in the private and public sectors, including as a City Manager, Assistant City Manager, Administrative Services Director, Acting Public Works Director and Management & Budget Analyst.
- General experience in government organization, administration and management including: direct supervision of financial services; budget preparation, forecasting and management; leading organizational improvements and efficiencies; and extensive experience with strategic planning, goal setting and performance management.
- Energetic, passionate and gregarious public servant with leadership experience in formal municipal planning processes that achieve strategic goals set forth by governing bodies and community participation.

## CALISTOGA, CALIFORNIA (POP. 5,280)

### CITY MANAGER

(FEB 2016 – APR 2019)

- **Directed** administrative operations of an award-winning organization including Finance/Budget, Fire, Police, Public Works, Parks & Recreation and Planning & Building.
- **Oversaw** entitlement approvals and construction of over \$500 million in new public investments including two new hotel/resorts, dozens of commercial projects including within the historic downtown, and oversaw growth of new wineries and tourism-related infrastructure.
- **Coordinated** major technology upgrades for municipal buildings including new fiber networks, firewalls and coordinated new licensing and software for enterprise resources planning.
- **Managed Significant Investment** in major capital infrastructure projects including: resurfacing over 25% of municipal streets and increasing Pavement Condition Index from 49 to 64 (31% increase); replacement of 1 sewer lift station and 1 water tank, both funded through developer fees or federal tax dollars, and; initiated citywide water/sewer system replacement and vehicle replacement schedules to address deferred infrastructure projects.
- **Directed** and implement major changes to citywide housing activities whereby Calistoga was 1 of 14 cities statewide to meet minimum housing goals. Also responsible for: modifying and removing ordinances deemed detrimental to housing development; assisting with the successful preparation of a voter-approved tax measure, resulting in \$512k annually for affordable and workforce housing, and; successfully oversaw entitlement of over 200 new housing units in a historically difficult region to construct new housing.
- **Financial Expertise** led to an increase in the General Fund Balance to 83% (FY19) and preparing a financial sustainability plan for the underfunded Water & Wastewater Enterprise Funds for the first time in City history. Additionally, the City funded \$2.8m in extra payments towards unfunded pension liabilities whereby reducing our Unfunded Actuarial Liability from 58% to 71%.
- **Negotiated** new labor agreements and contracts with at-will personnel, resulting in 100% of personnel positions being paid within 5% of comparative markets. Maintained excellent working relationship with all labor associations by holding monthly meetings to discuss current issues, solicit input/feedback into creating an ideal workplace, and discussing updates to personnel policies and procedures.

## AUBURN, CALIFORNIA (POP. 13,660)

### ADMINISTRATIVE SERVICES DIRECTOR

(SEP 2014 – FEB 2016)

- **Directed** administrative operations of the organization including finance, human resources, business licensing, risk management, information technology and labor. Planned, coordinated and presented the City's first Annual Community Survey which resulted in identifying priorities and preferences of residents and subsequently allocating over \$2.3m to prioritized infrastructure projects.
- **Coordinated** of \$26.5m annual budget including capital projects, personnel and operations. Results of fiscal management included two consecutive years of increasing fund balance (\$1.3m increase in FY15 alone, or 37%).
- **Lead Negotiator** of six (6) labor agreements. Agreements included elimination of unfunded liabilities in future retiree medical programs, elimination of unlimited vacation & sick leave accruals, and implemented modest salary increases to improve recruitment and retention.
- **Directed** human resources activities including administration of employee salary & benefit programs, hiring new employees while promoting increased diversity, and planning employee awards and recognition activities. Duties

also included oversight and administration of workers compensation, insurance programs and citywide risk management programs.

- **Project Leader** for a 2015 bond refunding, which resulted in significant annual savings. This effort freed up additional funds that were directed towards unfunded pension liabilities.
- **Oversaw** the successful consolidation of four (4) departments into two (2), resulting in significant financial savings to the City and improving efficiency in operations.

KNOXVILLE, IOWA (POP. 7,313)

ASSISTANT CITY MANAGER & ACTING PUBLIC WORKS DIRECTOR

(JULY 2012 – SEP 2014)

Assistant City Manager

- **Executive Management Team Member** providing broad oversight to multiple departments including executive management of \$16 million annual budget.
- **City Manager's Representative** on Red Rock Industrial Park & Rail Port Study, including drafting RFQ, preparing the professional services agreement, and supervising work related to a \$118,000 study for railroad expansion within the City's industrial park.
- **Directed** community development activities including budget preparation, property acquisitions, facilitation of public meetings, and other duties as required on a project-by-project basis.
- **Provided** construction oversight of new park facilities including playgrounds, recreation fields, shelter rehabilitations, stormwater improvements, cemetery improvements and others.
- **Coordinated** Comprehensive Plan Update. Responsibilities included facilitation of public meetings and hearings, and drafting new zoning rules and ordinances for review and recommendation.
- **City's Liaison** to volunteer boards including Airport Commission, Planning & Zoning Commission, Downtown Streetscape Committee, Board of Adjustment, Traffic Advisory Committee, Cemetery Commission, Historic Preservation Commission and Parks Advisory Board.
- **Contract Negotiator** for employee health plan, bi-annual labor agreements, engineering services, National Pollutant Discharge Elimination System (NPDES) permit application, etc.
- **Liaison** to Knoxville Chamber of Commerce and assisted with promotion of Knoxville including planning local, regional and national events such as Knoxville Nationals and RAGBRAI®.

Acting Public Works Director

- **Supervisor and Director** of Public Works Department. Duties included managing 25 FTEs, \$6.1m annual budget including administration and oversight of the wastewater facility, sewer system maintenance, engineering, fleet management, road maintenance and construction, and oversight of parks and public grounds.
- **Provided oversight of Sewer Enterprise System** including bond issuance activities, operations, maintenance and all financial reporting requirements. Duties also included implementing new purchasing requirements, equipment replacement schedules, and other creative, cost-saving measures which increased fund balance by 32% and cancelled 2 previously approved sewer rate increases.
- **Coordinated** City's 5-Year Sewer Forecast Model to allocate cash resources to infiltration & inflow (I&I) improvement program. Financial model identified total system costs including operations, debt service, system improvements and capital projects. After reallocating resources to priorities, City was able to fund a 5-year capital plan without increasing sewer rates.
- **Designed and Implemented** Infiltration & Inflow removal program to reduce clean water from the sanitary sewer system. Strategies included: use of new technology through GIS mapping and use of tablet devices; drafted and recommended adoption of I&I ordinance; purchased and installed flow meters throughout the city to measure reduction progress; and designed trenchless sewer lining project, all resulting in cost savings to the City.
- **Lead Negotiator** between City and Iowa Department of Natural Resources, successfully negotiating an Administrative Consent Decree to obtain full NPDES permit compliance without additional nutrient removal requirements, resulting in significant savings for residents/businesses in Knoxville.
- **Led regional collaboration** between City of Knoxville and surrounding agencies including Marion County Government, Knoxville Airport Commission, Knoxville Water Works and other service providers related to synchronization of capital improvement projects, events and enhanced community partnerships.
- **Managed** fleet and equipment replacement program activities to increase fund balance by 28% and reduce annual cash transfer requirements by \$100,000.

- **Coordinated** citywide public improvement projects including \$4 million downtown streetscape project, \$1.3 million annual street and sidewalk improvement projects, \$8.1 million of sewer improvement projects, storm sewer installations and all other capital projects.
- **Assisted** City Manager with drafting pre-development agreements including a 160-acre redevelopment project with 39 structures on the Department of Veterans Affairs Knoxville Campus.
- **Led, recommended and executed new strategies** for development review including streamlining review processes and outsourcing plan review, resulting in development review schedule reduction from 8 to 3 weeks.
- **Developed** pre-inspection review process for residential, commercial and industrial building projects which included pre-development meetings with stakeholders to identify concerns and improvements for building code, zoning ordinance, stormwater management and fire code.

OLATHE, KANSAS (POP. 126,216)

BUDGET ANALYST, MANAGEMENT ANALYST AND BUDGET INTERN

(SEP 2009 – JULY 2012)

- **Strategic Team Member** in organizational strategic planning and organizational performance management efforts resulting in “Certificate of Excellence,” from International City/County Management Association (ICMA) Center for Performance Measurement. The City used the Balanced Scorecard Methodology for strategic alignment across the organization.
- **Budget Team Member** responsible for coordinating and preparing annual \$52M personnel budget and prepared, translated and forecasted budget information in executive sessions and at council meetings. Annual evaluations included record of excellence in customer service.
- **Facilitated** of organization-wide training for strategic planning activities including department business planning and forecasting, performance measure reporting, and priority-based resource allocation modeling.
- **Sustainability Committee Member**, collaborating with multiple departments to draft city’s first Sustainability Plan and assisted with plan implementation to reduce organization-wide paper usage and desktop printers.
- **Strategic Alignment Committee Member**, collaborating with Human Resources and Police Department to align complex activities including department business plans, employee performance reviews and annual budget process into a single, strategic and comprehensive schedule.
- **Member of Strategic Planning Committee** for Olathe Community Center. Personal responsibilities included researching best-practices for regional community centers, fee studies, cost recovery models and other critical information related to this \$28.5 million legacy project.
- **Reorganization Committee Member** for consolidation and reorganization of Parks & Recreation, Development Services, and Fire Departments with responsibilities including building code program evaluation and surveying community stakeholders.

PERRY, UTAH (POP. 4,500)

ASSISTANT TO THE CITY ADMINISTRATOR, CITY ADMINISTRATOR’S OFFICE

(2008)

- **Assisted** with re-codification of municipal code including writing of ordinances and resolutions.
- **Prepared** and coordinated grant applications on behalf of the city administrator.
- **Data analysis** for potential mill levy increases, employee compensation, grants and future capital improvements.

## EDUCATION

### Master of Public Administration, University of Kansas

- **2010 Recipient** of KU Certificate for Service Learning
- Created neighborhood plan for Barker Neighborhood
- **Mark Keane Scholar** and member of Pi Alpha Alpha

### Bachelor of Arts in Political Science, Weber State University

- **AmeriCorps Service Member** with over 1,200 hours of voluntary community service
- **Faculty-Selected Student** to create and draft *Civitas* program that promoted civic engagement
- **Project-lead** on program evaluation of a city government’s “Fresh Air Friday” campaign

## PROFESSIONAL TRAINING

- PARSAC Risk Management Authority (JPA), board member and executive committee member
- FEMA ICS 100, ICS 200

- International City/County Management Association (ICMA), member & Credentialed Manager Candidate
- Alliance for Innovation, former ambassador
- Emerging Leader in ICMA Development Program receiving training on topics such as capital budgeting, finance, ethics, human resources management, labor relations and procurement
- Member of Olathe Leadership Team and completed award-winning Supervisory Leadership Training Program offered by the University of Kansas

#### ADDITIONAL WORK & VOLUNTEER EXPERIENCE

- Olathe Human Relations Commission, Volunteer
- Auburn Chamber of Commerce, Tourism Committee member
- Mentors for Utah Scholars, past program coordinator
- Boy Scouts of America, past Cub Scout Leader
- Trinity In-Home Care, Inc., Volunteer Project Coordinator, past member
- Olathe Public Schools YouthFriends, past professional mentor
- Leadership Auburn, Class of 2015
- Gold Country Fairgrounds Heritage Foundation, Board Member
- United Way of Greater Kansas City, past Resource Allocation Committee Member
- Tourism Business Improvement District, Member
- ADA Coordinator
- Olathe Persons with Disabilities Advisory Board, past member
- Church/Humanitarian Missionary in Republic of Armenia and country of Georgia

#### REFERENCES

Gabriel Engeland  
 City Manager  
 Sierra Madre, California  
 232 W. Sierra Madre Blvd.  
 Sierra Madre, CA 91024  
 (313) 575-5134  
[gabrielengeland@gmail.com](mailto:gabrielengeland@gmail.com)

Susan Sherman  
 Assistant City Manager  
 Olathe, Kansas  
 100 E. Santa Fe  
 Olathe, KS 66061  
 (913) 971-8700  
[ssherman@olatheks.org](mailto:ssherman@olatheks.org)

Tim Rundel  
 City Manager  
 Durant, Oklahoma  
 300 W. Evergreen  
 Durant, OK 74701  
 (405) 409-8375  
[tim.rundel@gmail.com](mailto:tim.rundel@gmail.com)

Chris Canning, Mayor &  
 Former Executive Director of  
 Calistoga Chamber of Commerce  
 1133 Washington Street  
 Calistoga, CA 94515  
 (707) 815-2105  
[calistogachris@gmail.com](mailto:calistogachris@gmail.com)

Steve Rogers  
 Town Manager  
 Yountville, California  
 6550 Yount Street  
 Yountville, CA 94599  
 (707) 310-2139  
[srogers@yville.com](mailto:srogers@yville.com)

Steve Campbell  
 Fire Chief  
 Calistoga, California  
 1113 Washington Street  
 (707) 889-2783  
[scampbell@ci.calistoga.ca.us](mailto:scampbell@ci.calistoga.ca.us)

# Matthew J. Fuhrer

---

## SUMMARY

More than ten years of local government experience with expertise in the following areas:

- Strategic Planning and Operations Analysis
- Program Evaluation
- Policy Execution
- Media Relations
- Community and Intergovernmental Relations
- Financial Operations and Budget
- Customer Service
- Organizational Change and Development

## RELEVANT LOCAL GOVERNMENT EXPERIENCE

*City of Cocoa, FL*      *November 2016 – Present*

### **City Manager's Office- Assistant City Manager**

Executive level administration of a full-service city (19,272 Pop.) and regional water utility (83,000 customers). Direct responsibility in the areas of city engineering, streets, stormwater, grounds, capital projects, facilities, fleet management, information technology and parks and recreation liaison. Work on a daily basis with the members of City Council, community and staff members.

### *Highlights and Contributions*

- Prioritized goals of the City Council, rates for the utility fund, rate for the fire assessment, and rate for the stormwater fund in developing the city-wide budget annually
- Collaborated with multiple City teams to relocate and construct three fire stations (community buy in, fire assessment rate adjustment, special revenue bond and special revenue bond validation) with an end result of providing a four-minute response time to over 90% of the community
- Implemented a city-wide performance benchmarking program (Florida Benchmarking Consortium) in order to develop metrics for evaluating municipal services internally and with peer organizations
- Coordinated response efforts for Hurricane Matthew and Hurricane Irma Response related to debris management, waterfront cleanup (approximately \$1.7M Damage), waterfront planning and restoration (approximately 3.1M)
- Negotiated the acquisition of a regional waterfront park with Brevard County and addressed future operation and maintenance requirements
- Review and approve each City Council Agenda and work with staff to develop the timing and content
- Served on multiple hiring teams of director and critical level staff positions and engaged in disciplinary action when needed to preserve effective levels of municipal services
- Coordinated a study through the Center for Public Safety Management operation and workload analysis for the police department and implementation
- Participated as a member of the negotiation team for the City's five collective bargaining units with two being new
- Oversee and supervise the implementation of a new enterprise resource plan (processes and software) city-wide

*City of Cocoa, FL 2014 - 2016*

## **City Manager's Office- Special Assistant to the City Manager**

Key staff member of the City Manager's Office in the implementation of new programs, projects and policies. Worked directly with the community members of City Council and staff to carry out the policies set by the City Council. Direct responsibility to design, facilitate and implement a community based five year strategic plan for the City.

### *Highlights and Contributions*

- Developed with the City Manager the annual budget process and document for the general fund, community redevelopment agency and each enterprise fund
- Initiated and implemented a community based five-year strategic plan by collaborating with community stakeholders and internal staff to address the identified strategic issues of the City
- Collaborated with the City team to induce the development of an approximately 430,000 sq. ft. cold storage distribution center
- Developed with the City Manager annually the city's legislative priorities and legislative communication throughout the legislative sessions
- Addressed citizen and customer complaints and inquiries at the City Manager level by working with departments and coordinating services to effectively address the community concerns
- Participated as a member of the negotiation team for the City's three collective bargaining units (Police, Fire, General Workers) and achieve a small measure of pension reform with the public safety pensions.
- Designed and implemented an offender re-entry program for city-wide grounds maintenance

*City of Lakeland, FL 2012 - 2014*

## **Office of the General Counsel Police Department**

The department has an authorized strength of 231 sworn full-time officers (1 chief, 3 assistant chiefs, 4 captains, 11 lieutenants, 35 sergeants, and 177 officers) and 119 civilian employees. Coordinated with a team of experienced personnel including Civilian Employees, Officers, Detectives, and Supervisory Command Staff within the Office of Professional Standards at the Lakeland Police Department to professionalize the department through state and national accreditation, process improvement, and policy and procedure revisions.

### *Highlights and Contributions:*

- Redesigned the City's Performance Budget section for the Police Department
- Assisted unit commanders in the development of policy consistent with national and state accreditation standards
- Achieved accreditation (CFA and CALEA) after it was removed by authorizing agencies through developing department policies and worked with department members to ensure the policies were adhered to
- Coordinated and organized the completion of unit workload assessments, strategic planning, and budgetary documents
- Contributed to a city-wide workforce administration process improvement project



*University of South Dakota Police Department- Vermillion, SD 2008-2012*

## **University Police Department**

While attending graduate school I worked full time in a security role for the University Police Department.

### *Highlights and Contributions:*

- Represented the department in the hiring and selection process of new officers
- Responsible for the training of new officers
- Assisted the Chief of Police and Command Staff in the development of department policy

*Campbell County Sheriff's Department- Gillette, WY 2006-2008*

## **Deputy Sheriff**

Maintained the safety and security of citizens through responsible law enforcement, warrant service, court security, and community involvement.

### *Highlights and Contributions:*

- Completion of State Law Enforcement Academy certification and scored above 95% in measured disciplines of academics, physical fitness, firearms, and situational response.
- Received specialized training in Spanish language, fingerprinting, and firearms which I taught to all department personnel.

---

## **EDUCATION AND CREDENTIALS**

**Master of Public Administration-** Emphasis in State and Local Government  
University of South Dakota (Anticipated)

**Bachelor of Arts-** Criminal Justice  
University of South Dakota

---

## **PROFESSIONAL ASSOCIATIONS**

International City/County Management Association- Full Member

Florida City and County Managers Association- Full Member

- 2013 – 2015 Member- Professional Development Committee
- 2016 Member- Conference Planning Committee
- 2019 Member- Conference Planning Committee

Space Coast Public Managers Association- 2017–2018 President

Space Coast Public Managers Association- 2014 – 2019 Member

## **COMMUNITY INVOLVEMENT**

Chair - Endeavour Elementary Community Partnership School Leadership Committee 2018 - present

Member – Endeavour Elementary Executive Cabinet 2016 - present

Vice President – Cocoa Community First Non-Profit 2015 – 2017

---

## **REFERENCES AVAILABLE UPON REQUEST**

June 27, 2019

Winter Springs City Manager Search  
1126 E State Road 434  
Winter Springs, FL 32708-2715

Dear City Manager Search Committee,

I am interested in the Winter Springs City Manager position. I learned about the job posting on the ICMA web site and found my talents and experience to match your requirements for the position.

I have an extensive knowledge of the day-to-day requirements to effectively manage a large organization and am currently Town Manager in Poland, Maine. I have prepared municipal budgets that are effective and that keep the mil-rate down. Additionally, I prepared and executed a \$30 million dollar budget for a large U.S. Navy organization with 3000 staff and another budget of \$50 million for a commercial firm with 100 staff.

In addition to my experience as a Town Manager, I have also served in responsible, senior roles as a Chief Executive Officer and Board Director for a commercial firm in Singapore and as Chief of Staff (U.S. Navy Captain) for the group that managed all logistics for the U.S. Navy in the Western Pacific.

I have experience managing large capital projects, am playing an active role in economic development here in Poland, and have solid personnel administration skills.

I also have a solid education background. I hold a Master in Public Administration, Kennedy School of Government, Harvard University, a Bachelor of Science in Marine Transportation, Massachusetts Maritime Academy, and was a Fellow, Security Studies Program, Massachusetts Institute of Technology.

What I would bring to this role is my current experience as a Town Manager and the character, integrity, and honesty of a career naval officer along with the senior level leadership and management skills I have developed during my professional life. I would like to put those skills to work for Winter Springs as City Manager. Please do call me at 207-440-7379 or email me at [matthew.j.garside@gmail.com](mailto:matthew.j.garside@gmail.com).

Sincerely,



Matthew Garside

**Matthew J. Garside**  
**1231 Maine Street, Poland, Maine 04274**  
**Email: [mgarside@polandtownoffice.org](mailto:mgarside@polandtownoffice.org) Phone: 207-440-7379**

---

**Profile & Value.** Senior executive with 20+ years' experience leading and managing government and commercial organisations from start-ups with 250 staff to groups with 3,000 staff. Able to quickly adapt to changing circumstances, create strategy and drive change throughout organizations. Strong interpersonal and leadership skills. Adept at attracting and retaining talented employees and building long term successful business partner relationships.

### **Qualifications and Professional Expertise**

#### **Human Relations.**

- Formally evaluated direct reports on an annual basis with a mid-year review. Reviewed and approved evaluations of all other staff.
- Reviewed and approved/declined all Quality Step Increases for staff. Approved and awarded monetary awards for superior performance.
- Participated in the selection process and ultimately approved all new hires. Ensured process was objective and followed established procedures.

#### **Financial Management.**

- Directed administration of \$50M in revenue with full P&L responsibility for commercial firm with 100 staff. Developed and executed \$30M budget for large U.S. Navy organisation with 3000 staff.
- Established fuel ordering and accounting tracking program to manage fuel for all U.S. Navy ships in the Western Pacific – produced \$25M in cost avoidance in the first year.
- Executed centralized order processing plan; reduced workforce from 53 to six and order processing locations from 11 to one, achieved \$6M/year in manpower savings, no reduction in customer service.
- Prepared and submitted a \$7M municipal budget with no increase in the mil rate and no cuts to town services.

#### **Management.**

- Managed \$8.9B of inventory; \$3.0B of end user inventory, \$5.6B of technically advanced rotating stock, sourcing and delivery of \$446M of fuel.
- Integrated air, ground, and sea transport, and leveraged contracts with suppliers to produce a holistic logistics plan to support 70 recurring customers.

#### **Leadership.**

- Led 3000 person multinational workforce based in Singapore, at sea and ashore throughout the Asia Pacific region. Managed fleet of 45 ships, including operations, scheduling, and maintenance, total capitalization of \$16.1B.
- Led three United States Navy organizations, managed budget, operations, training, maintenance, human relations. Responsible for overall performance.
- Chief Executive Officer and Board Director for an oil and gas firm in Singapore with \$50M in revenue and 100 staff.

#### **Public Affairs.**

- Supervised public affairs department that worked with foreign media outlets in 11 South East Asian nations to portray the U.S. Navy in a positive light, published a local weekly newsletter to keep staff in Singapore informed, published articles in U.S. media regarding U.S. Navy activity, and maintained a web site.

**Town Manager, Town of Poland**

**2017 - Present**

Directed and supervised the administration of all departments with \$7M budget and 24 full time and 36 part time staff.

- Prepared and submitted municipal budget and capital improvement plan. \$7M plan provided for continuation of essential services and investment in capital projects without increasing the mill rate.
- Applied for and obtained \$88K in grant funding. Funds were used to acquire an electronic speed sign, install an electric vehicle charging station, construct a pedestrian bridge and purchase Fire Rescue training equipment.
- Addressed several long standing maintenance issues; Town Office interior painting and kitchenette, Town Hall bathrooms. Partnered with contractors to save money and time. Result, long standing projects now complete with minimal expenditure of tax dollars.
- Facilitated the Town's purchase of a summer camp. Presented proposal at a Special Town meeting to purchase the camp, negotiated terms with the seller, resolved boundary line and water issues.

**Caring for Elderly Parents**

**2013-2017**

**Chief Executive Officer and Board Director  
Reflect Geophysical, Singapore**

**2012-2013**

Directed administration of \$50M revenue with full P&L responsibility and 100 staff. Provided marine geophysical services, seismic acquisition services and technical and operational support for oil and gas companies venturing into the Asia Pacific region.

- Developed plan to address \$80M in debt. Liaised with 56 trade creditors to address outstanding debt, maintain communication and ensure vital services for seismic operations were supplied on a cash basis. Worked with largest creditor (\$50M) to maintain support and stave off legal action.
- Retained 77 employees through extreme financial hardship. Kept employees informed, apprised of challenges, what the company was doing to meet those challenges, and how their continued participation enabled the firm going forward.
- Right sized workforce. Cut redundant, underperforming staff. Saved \$54K/month.
- Built and maintained relationship with major Indian oil company. Reflect was delayed in starting \$35M contract. Established regular communication cadence, kept company informed, and built trust such that the contract remained viable.
- Effectively managed 16 legal challenges ranging from arrest of vessel to winding up petitions. Sourced and directed legal representatives. Directed responses and action such that the company was not encumbered and could continue operating.
- Saved \$11K/month by restructuring communications architecture. Communication costs were averaging \$16K/month. Reviewed cost drivers and eliminated expensive and redundant communications path.
- Managed \$5M/month in operating costs.

**Chief of Staff, Logistics Group Western Pacific, Singapore****2005-2012**

Led Logistics Group Western Pacific, a U.S. Navy organization of 3000 based in Singapore, at sea, and ashore in the Asia Pacific region. Directed 100 Singapore based military and civilian staff across five areas; logistics, marine maintenance and repair, marine salvage, operations, and military exercises/engagement. Directed operations of 45 ships. Managed \$8.9B of inventory, sourcing and delivery of \$446M of fuel. Integrated air, ground, and sea transport, and leveraged contracts with suppliers to produce a holistic logistics plan to support 70 recurring customers.

- Kept group focused and on budget. Developed budget. Previously, funding, \$30M/yr, had been expended with no discipline. Validated requirements, justified future/ongoing expenses. Produced budget that met present and future requirements.
- Developed strategic plan that looked out five years. Set goals and built a business plan to achieve them. Briefed staff on goals, business plan, and how they could contribute to making it a success.
- Approved all significant HR actions; hiring new staff, termination of staff, disciplinary matters, monetary awards for performance. Resolved personnel issues diplomatically and objectively.
- In addition to directing major departments, directly supervised supporting staff; human relations, administration, legal, medical, facilities, IT, and public affairs.
- Built relationships with multiple stakeholders to further the goals of the organisation. Established ongoing relationships with naval leaders in 11 South East Asian nations along with U.S. Government officials in those countries. Worked closely with the Republic of Singapore at the local government level and representatives from the United Kingdom, New Zealand, and Australia to foster relationships that enabled the U.S. Navy presence to continue as well at more senior levels to further U.S. strategic goals.
- Achieved significant cost and manpower savings. Centralized marine fuel ordering and accounting for all U.S. Navy ships operating in the Western Pacific. Matching each customer with the lowest cost and most efficient fuel source produced \$25M in cost avoidance in the first year. Also centralized order processing for subsistence and dry goods provided to customers at sea. Reduced workforce from 53 to six, achieved \$6M/year in manpower savings.
- Led cross functional U.S. Navy logistics relief effort during 2011 Japanese Tsunami. Organized supply chain to move materiel to load port and on to customers at sea and ashore, used six logistics ships to move 7827 tons of life sustaining supplies to the affected area, and provide 8.2 million gallons of fuel to 18 USN ships. Conducted relief operations in a nuclear radiological environment without impacting delivery schedule.

**Commanding Officer, Mobile Security Squadron 7, Guam****2003-2005**

New organisation – start-up. Provided armed security for naval units operating throughout the Western Pacific and Middle East. Directed training and operational certification of three 75 man and 11 five man security teams. Administered \$1.5M budget. Oversaw maintenance and repair for six security vessels, supporting rolling stock, and inventory of over 300 weapons. Maintained quick reaction force able to respond in 24 hours for emergent security requirements. Developed supply chain for logistics requirements.

- Directed construction of five new buildings and remodelling of one warehouse. Oversaw physical construction of facilities, installation of secure email system, procurement and installation of furniture and supporting equipment.
- Developed and executed training plan. Plan included all aspects of armed security operations to include entry control point, physical searches, maritime force protection, embarked security teams for large vessels and shore based assets, weapons training, physical fitness training.
- Directed flow of new hires. Developed training plan that was conducted in San Diego prior to new personnel arrival. Reduced length of San Diego training as Guam facilities and training plan matured. Result - new hires arrived at the right time with the right level of training to contribute.
- Developed marketing plan to sell group's capabilities and establish customer base. Won job to provide security for Seventh Fleet Flagship (where my supervisor worked). Flawless execution of security operations established credibility with my supervisor and allowed potential customers to view product. Result - established 11 recurring customers.
- Excellent reputation resulted in security work aboard vessels operating in the Mediterranean Sea, Persian Gulf, Indian Ocean and Western Pacific. Jobs ashore included providing security for Iraqi oil platforms, convoy security in Iraq, security for a Joint Army and Navy Special Operations base and airfield in the Philippines.
- Led cross functional team of 120 specialized staff, a two aircraft Helicopter Detachment, and large merchant vessel in support of counter terrorism operations to locate and capture terrorists at sea. Provided covert afloat forward staging base for Army Special Forces and Naval Special Warfare craft and personnel.
- Provided security for relief efforts associated with the 2005 Asian Tsunami. Deployed 35 staff to establish a secure environment for relief operations. Five month effort allowed non-governmental organizations to partner with U.S. Navy Medicine to provide much needed medical and disaster relief support.

**Education**

<b>Harvard University</b> Kennedy School of Government, MPA - Public Administration	<b>1996-1997</b>
<b>Massachusetts Institute of Technology</b> Fellowship - Security Studies Program	<b>1996-1997</b>
<b>Massachusetts Maritime Academy</b> BS - Marine Transportation	<b>1978-1982</b>



# DARIN W. GIRDLER

---

1104 35<sup>th</sup> Avenue Ct. • East Moline, IL 61244  
618.971.8276 • dgirdler@gmail.com

---

**Experienced Professional with broad-based expertise in all facets of Budgeting, Collective Bargaining, Benefit Analysis, Inter/Intra Governmental Relations, Contract Negotiation, Utility Development, Construction, Project Management, Human Resources, Administration and Finance. Technological leader, innovative, creative problem solver, energetic, confident, reliable, loyal – ability to work collectively or independently and manage multiple tasks.**

## EXPERIENCE

---

**City of East Moline, IL**  
**City Administrator**

**June 2016 – January 2019**

- Responsible for all aspects of budgeting, city functions and multiple labor negotiations – \$40M budget.
- Serve as the City's chief administrative officer with responsibility for all day-to-day operations.
- Fostered and maintained positive relationship with schools, businesses, County, State and Federal government agencies and the citizenry.

**City of Pekin, IL**  
**Assistant City Manager and City Manager**

**October 2011 – February 2016**

- \$70M budget – Over 200 employees and six collective bargaining agreements to work with as needed.
- Served as the City's chief administrative officer with responsibility for all day-to-day operations.
- Municipal and economic development programs went hand-in-hand – with many successes.

**Terra Properties, Inc, Highland, IL**  
**Brokerage, Development and Project Management**

**November 2007 – May 2011**

- Direct all development and project activities for owners, clients and independent developers.
- Negotiate property acquisition, sale contracts and lease agreements for all parties involved.
- Site/facility assessment and evaluation – zoning compliance – utilizing past Municipal experience.
- Network with outside interests, owners and community leaders in addition to developers and banks.
- Acquire new assets for the portfolio using complex financial modeling and stabilization modeling.

**CB Richard Ellis, Edwardsville, IL – St. Louis, MO**  
**Vice President – Brokerage Services – Development of Illinois Market**

**January 2005 – November 2007**

- Continual interaction with government officials for project expedience and completions.
- Project/site selection and acquisition including land use compliance and all encumbrances.
- Negotiate property acquisition, disposition, sales contracts and lease agreements with complex terms.
- Managed transition from Grubb & Ellis|Krombach Partners to Trammell Crow Krombach Partners to CBRE in Illinois – very dynamic transitions.

**City of Highland, IL**  
**City Manager – ICMA Credentialed Manager**

**August 1996 – January 2005**

- Responsible for all aspects of budgeting, utility operations, city functions and multiple labor negotiations - \$35M budget – Over 200 employees and five unions to work with as needed.
- Served as an Executive Member of the IMEA Board of Directors for Electric Utility.
- Fostered and maintained positive relationship with schools, businesses, State and Federal government agencies and the citizenry.

**City of Farmer City, IL**

**April 1994 – August 1996**

*City Administrator*

- Day-to-day administration of a full service community.
- Responsible for utility operations, management of daily staff, personnel and budgeting.

**EDUCATION**

---

Illinois State University  
B.S., Business Administration

**1988-1992**

# Ernest C. Hoch

---

## Summary of Qualifications

A self-motivated, results-oriented executive with more than 30 years of Executive Management experience. A successful record of achieving company and personal goals through persistent effort and the development of long-term relationships. An effective communicator with proven leadership, financial, operational, problem-solving public relations and decision-making capabilities. Areas of expertise include:

- Executive Management
  - Public and Private Sector
- Public Works and Engineering
- Non-profit Management
- Financial Management
- IT System Management
- Economic Development
- Business Development
- Sales and Marketing
- Program Management
- Construction Management
- Site Development
- Property and Facilities Management
- Real Estate Sales
- Emergency Management
- Solid Waste Management
- Fleet Services
- Aviation

---

## Professional Experience

### **Jarrell Properties, Inc. Fredericksburg, Virginia**

*Real Estate Development, Property Management*

2016 - 2019

#### **Chief Operation Officer**

Jarrell Properties, Inc. is a privately-owned construction and development corporation actively involved in the real estate market in central and northern Virginia. From its headquarters located in downtown Fredericksburg, Virginia, and with an eye toward smart growth, the company is currently developing numerous residential subdivisions and commercial projects. The company also owns and manages its own residential and commercial property portfolio.

As Chief Operating Officer, I was tasked with operating and reorganizing the family business. My responsibilities included the development of over 1,000 residential lots on multiple sites, commercial property development and new commercial construction management. I reorganized their commercial and residential leasing portfolio and implemented new operational procedures, reducing expenses by over fifty percent and managed growth of over five hundred percent. Financially, I managed and reorganized over seventy separate companies with various ownerships and partnerships. My additional responsibilities included real estate sales with American Allstar Realty, the reorganization of a Title and Escrow Company and an Insurance Company. I positioned the company from a small staff organization to an integrated organization poised for future growth. I hired several new positions within the company and transitioned young family members into several of those positions with increasing responsibilities. The company is now on the right path for the future.

# Ernest C. Hoch

---

## **Culpeper County, Virginia**

*County Government*

2015 - 2016

**County Administrator / CEO**

County Administrator for Culpeper County, Virginia. As the County Administrator, I directed the daily business of the county. I managed all departments and the complete financial responsibilities of the county. Culpeper has a population of 50,000 and a budget of 160 million dollars. Projects that I completed included: developed a pretrial services program including securing funding in the Governors 2017-2018 budget, purchase of property for

courthouse expansion, courthouse planning, expansion of the economic development office, planning for a new county wide financial system, airport master planning, annual air show and hangar construction, adoption of the 2015 county wide comprehensive plan, enacted farm taxation reform legislation, improved the emergency communications systems, secured a new county wide VOIP phone system, rural broadband and cell phone planning, secured enhanced county wide fiber connections and IT upgrades, major capital construction projects, major improvements to the animal shelter and animal control, securing several grants (microenterprise grant, for small business start-ups, grant for bio-fuel planning, rural broadband development grant) and secured over 67 million dollars in new business development including \$500,000 in state incentives and 110 new jobs in eight months.

## **Madison County, Virginia**

*County Government*

2012 - 2015

**County Administrator / CEO**

County Administrator for Madison County, Virginia. As the County Administrator, I directed the daily business of the county. I managed all departments and the complete financial responsibilities of the county. Projects that I completed included: reorganized the solid waste and recycling center and saved the county 1.2 million dollars, secured a ten million dollar capital improvement financing at 2.15% fixed for 15 years saving \$800,000, closed out a courthouse project and saved the county over \$200,000, secured a new consolidated financial system that will combine the school system finances with the county, secured major business expansion project of 4.5 million dollar including State incentive grants and 25 new jobs, developed a county wide tourism and economic development department, constructed a new tourism office and visitor center, main street improvement projects, developed an initiative to obtain a road into the Shenandoah National Park and develop national connections with the Park and the Hoover Presidential Library, began a major tourism and economic development initiative that the community is fully engaged with and activity participating in, completed service contract reviews, county employee salary study and a major capital and debit service plan, enacted contract changes resulting in savings and improved services of the county wide health insurance, GIS system and in house facility planning. I also serve as the public information officer and have developed open communications with the media and citizens.

# Ernest C. Hoch

---

**City of Harrisburg, Pennsylvania**  
*City Government, Capital of Pennsylvania*  
**Director of Public Works & City Energy Manager**

2010 - 2012

I was the Director of Public Works and the city energy manager for the City of Harrisburg, PA the Capital of Pennsylvania. This was a senior cabinet level position confirmed by City Council and reported to the Mayor. I was responsible for the complete portfolio of City Services including the City Engineer, City Energy Office, Solid Waste and Recycling, Streets and Highways Division, Sewer Bureau 40 million gallons per day (MGPD), Water Bureau 20 (MGPD), Traffic Engineering, Demolition, Building Services, and the Vehicle Maintenance Center servicing a fleet of more than 400. I was responsibility was for 150 employees and a 45-million-dollar budget. I successfully managed several city-wide disasters including two record floods, the five-year drill and preparation exercise for Three Mile Island nuclear plant, several major wind storms, and a 36" water main break that threatened the entire city water system. I worked with the State appointed receiver uncovering corruption and contributed to large parts of the recovery plan. I was recommended by the receiver to lead the city as the chief operating officer. The key to my success was working with an engaged community.

**Pittsylvania County, Virginia**  
*County Government*  
**Director of Public Works**

2007 - 2010

I was the Director of the Pittsylvania County Public Works Department, which is the largest county in Virginia consisting of almost 1000 sq miles. My responsibilities included the counties sub title-D landfill and closed cells on a 400-acre footprint, the county wide solid waste and recycling collection system, building and grounds department, animal control department, industrial development projects and water development construction. I increased efficiency by 25% and improved customer service in all departments.

**Trinity Property Services of Virginia, Smith Mountain Lake, Virginia**  
*Property Management Firm*  
**Vice President / Property Manager / REALTOR®**

2005 - 2007

As co-owner of this startup company I grew annual sales to \$400,000 and positioned Trinity as the premier janitorial / property management firm at Smith Mountain Lake, Virginia. Company provides janitorial, property / facility management and real estate sales throughout Southwest Virginia. Clients include municipal, industrial, commercial, homeowner associations and private residents.

**Waste Management of Virginia, Inc., Virginia, West Virginia & North Carolina**  
*The world's largest publicly traded waste & recycling company with revenues of \$13 billion*  
**Municipal Marketing Manager**

2001- 2005

As the companies, senior executive for municipal and industrial accounts throughout Virginia, West Virginia and portions of North Carolina I was responsible for the combined sales of over 200 million dollars annually. I produced new sales of more than 10 million dollars and achieved retention rates of 95%. I saved Coors Brewery over two million dollars annually by improving their recycling operations and developing a national partnership

# Ernest C. Hoch

---

with them. I directed the regions industrial and municipal sales including; collection, recycling, transfer stations, and landfills. I secured Municipal contracts for Blacksburg, Charlottesville, Petersburg, Duck, NC, Currituck NC and many more.

## **Angle Flight (formally AirLifeLine), Virginia Beach, VA**

*A national non-profit charitable organization providing free air transportation*

1999 - 2001

### **Director of Pilot and Patient Services**

I directed the operations of over 1,500 private pilots who fly ambulatory patients to medical facilities for diagnosis and treatment. Increased missions by 50% by raising public awareness. Responsible for, pilot recruitment, patient outreach, public relations, corporate support and fund raising. In 2004 AirLifeLine merged with Angelflight.

## **American Building Maintenance, Inc., New York, New York**

*Publicly traded facility services contractors with revenues of \$4.8 billion*

1997 - 1999

### **Branch Manager**

I was a senior executive for American Building Maintenance in New York City and had responsibility for operations and sales of over \$100 million dollars. I consistently operated under budget and exceeded sales and operations goals by 20%. Accounts included major Class A office properties, property management companies, institutional accounts, manufacturing facilities, pharmaceutical companies, non-profit organizations, educational accounts, retail and transportation companies. Services provided included Mechanical, Janitorial, Carpentry, HVAC, & Security. I developed and directed the activities of six district managers including the window cleaning division at the World Trade Center. I managed the start-up of all new accounts and the development of training programs for more than 2,500 union janitorial personnel. I maintained strong working relationships with key players from major accounts. I analyzed project specifications and labor/operational costs to formulate competitive bids and proposals.

I championed the prompt and diplomatic resolution of client problems and concerns, and worked closely with unions to mediate labor disputes and other work-related issues. I managed a smooth transition of a newly acquired company after a major acquisition in 1997, provided educate to new personnel in ABM's policies, procedures and philosophies, streamlined and integrated operations.

## **Unity Environmental, Hoboken, New Jersey**

*Solid Waste and Recycling Company*

1984 - 1997

### **Senior Vice President Sales & Marketing - 1990-1997**

I was responsible for company's sales and marketing activities; a solid waste and recycling company with annual sales of \$80 million. Increased new sales by more than 20% each year. Developed new business and serviced existing accounts through extensive marketing and networking.

- Developed innovative marketing strategies and sales campaigns; successfully negotiated national contracts with major financial, property management, retail, manufacturing, commercial printing, and paper mill accounts.

# Ernest C. Hoch

---

- Interfaced extensively with The New York City Departments of Sanitation and Consumer Affairs to create the current recycling code (Local Law 19 & 87) that was instituted citywide.
- Increased sales by developing office recycling programs, which are now recognized as industry standards.
- Created and produced a marketing/educational video to promote company's services.
- Designed new state-of-the-art solid waste management equipment and handling systems.
- Planned and conducted lectures for property managers and owners on recycling operations and laws.

## **Director of Operations- 1984-1990**

Planned, coordinated, and executed hands-on operations management functions. Supervised, trained, and directed activities of 200 employees and over 50 trucks to ensure that operational objectives were achieved.

- Managed and directed all operations including dispatching, routing, scheduling, union relations, client relations, equipment maintenance, and accounting.
- Interviewed, evaluated, and hired prospective employees.
- Managed 1000 TPD material recovery facility.

## **Education / Professional Development**

Ocean Technical 4.0 GPA, top in my class. I have furthered my education with countless continuing education courses including but not limited to: Dale Carnegie Leadership Training for Managers (LTM), Advanced Sales Training (AST) I & II, Public Speaking, Mosley Dickinson Real Estate Academy, BOMA training, Gibson Air Academy (instrument rated pilot), Scuba training (rescue diver certification), Joyce Engineering: Class A Underground Tank Operator, Waste Management Facility / Landfill Operator Class I & II, and FEMA Emergency Management: ICS 100-200-300-400- G775 & Debris Management and ICMA.

I have been a professional senior manager for over 30 years. I have a vast array of executive experience in private, non-profit and public sector including but are not limited to: Senior executive responsible for a 100-million-dollar budget with 2,500 union employees in New York City, the Director of Public Works for Harrisburg, the Capital of Pennsylvania and County Administrator for Madison and Culpeper, Virginia.



# Ernest C. Hoch

---

## Activities/Affiliations

- Southwest Virginia Solid Waste Management Association (SVSWMA), Board member / VP, 2009
- Building Owners & Managers Association (BOMA)
- National Solid Waste Management Association (NSWMA)
- FAA-licensed instrument rated pilot
- Licensed Virginia real estate agent
- Virginia Notary
- Class A Commercial Drivers License with all endorsements
- Certified Rescue Diver
- Certified Class I & II Landfill Operator
- NACO & ICMA Member
- Virginia Association of Counties, Statewide Finance Committee, Commission on Local Government
- United Way Director
- Blue Ridge Regional Juvenile Detention Center, Board Member
- Central Virginia Economic Development, Board Member
- Shenandoah National Park Tourism Committee member

## Perform volunteer work for numerous charities and non-profit organizations (partial list)

- President / Board Member of Smith Mountain Lake Chamber of Commerce (2008)
- Director of Franklin County Chamber of Commerce (2006)
- Ambassador with the Franklin County Chamber of Commerce
- Take Pride in Smith Mountain Lake (Chairman 2004 & 2005)
- PTO Dudley Elementary School (President 2004 & 2005)
- BoxwoodGreen HOA (President, Board Member 2003 / 2005)
- Board Member of the Tri County Lake Association (2006-2009)
- Smith Mountain Lake Marine Volunteer Fire / Rescue & Dive Team, Rescue Diver
- Smith Mountain Home Tour (Sponsor and Auction committees)
- Roanoke Shiners (Past Public Relations Chairman)
- Rocky Mount Lodge # 201, Past Master of the Lodge
- Angel Fight (AirLifeLine), Volunteer pilot, and member of the community outreach committee.
- Member of the Civil Air Patrol
- Member of the Franklin Aviation Network
- Big Brothers Big Sisters (big brother)
- Member of Trinity Ecumenical Church, Moneta, VA
- Madison County Volunteer Fire Department, Volunteer Fireman
- Madison County Lions Club

## References on request

**ALPHONSO JEFFERSON, JR.**  
**(C) 407-376-2541**  
**ALPHONSOJEFFERSON@MSN.COM**

**CAREER SUMMARY**

An effective and innovative leader with demonstrated performance in collaborating, interfacing and working successfully with various elected officials, executive staff, senior management, citizens and community leaders in public and private organizations, and built effective and productive teams to achieve the mission, vision and goals of organizations. Senior level executive with twenty (20) years of experience in governmental and private sectors with skills in the following areas:

<b>Strategic Management</b>	<b>Financial Management</b>	<b>Workforce Management</b>	<b>Leadership Management</b>
Strategic and Operational Planning	Revenue, Research and Statistical Analysis	Human Resources and Operational Management	Listening Leader and Complex Decision Making
Critical Thinking	Procurement and Project Management	Organizational Alignment and Development	Relationship Building and Nurturing
Business Process Improvement	Contract Management and Negotiation	Recruitment and Retention	Building High-Performance Teams
Process and Performance Management	Treasury Management	Training and Development	Intergovernmental Coordination and Public Affairs
Growth Management and Economic Development	Financial Management, Budgeting, Capital and Facility Planning	Organizational Change Management	Development and Execution of Strategy: Short & Long-Term View

**EDUCATION**

**Master of Business Administration**, University of Phoenix, Orlando, Florida,  
**Bachelor of Science in Business Administration**, University of Central Florida, Orlando, Florida  
**Associate of Arts, General Studies**, Valencia Community College, Orlando, Florida  
**Executive Leadership Program**, Certificate of Completion, Rollins College, Winter Park, Florida  
**Lean Six-Sigma Green Belt**, Certificate of Completion, Villanova University, Online  
**Certified Professional in Human Resources (PHR)**, Society for Human Resources, Human Resources Certification Institute  
**Certified DDI Facilitator, Customer Service and Leadership Facilitator**, Development Dimensions International and AchieveGlobal  
**Certified Florida Redevelopment Professional**, Florida Redevelopment Association

**RELEVANT EXPERIENCE**

**Broward County Board of County Commissioners, FT. LAUDERDALE, FL 04/2012 – PRESENT**

**Assistant County Administrator – County Administration**

County Administration executive with the responsibility in the execution of policies and procedures for a full service county governmental entity with human services, airport and port operations, mass transit, public works and jail functions in support of 5,400 employee operation and \$3.3B budget. Appointed by and directly reports to the County Administrator and serves as the primary liaison to the Office of Management and Budget, Regional Communications and Technology (911 Emergency System), Public Works, Emergency Management, Municipal Services District (Unincorporated Area), Judiciary, Sheriff, State Attorney, Public Defender, Supervisor of Elections and Property Appraiser. Together these agencies comprise more than 50% of the County's operating budget. Oversight of agency budget development, coordination and administration is a key responsibility, including both operations and capital budgets. Duties also include performing research, conducting a variety of special studies and implementing administrative policies. Functions also include the coordination of the funding program and bid solicitation process in support a \$300M County Courthouse building program. Broward County is the 2nd largest county in the State of Florida with 9 single member districts.

**Assistant to the County Administrator – County Administration**

County Administration executive with the responsibility in the execution of policies and procedures for a full service county governmental entity with human services, airport and port operations, mass transit, public works and jail functions in support of 5,400 employee operation and \$3.3B budget. This is high level professional position that compares to an Assistant County Administrator position in comparable organizations. Appointed by and directly reports to the County Administrator and serves as the primary liaison to the Office of Management and Budget, Regional Communications and Technology (911 Emergency System), Public Works, Emergency Management, Judiciary, Sheriff, State Attorney, Public Defender, Supervisor of Elections and Property Appraiser. Together these agencies comprise more than 50% of the County's operating budget. Oversight of agency budget development, coordination and administration is a key responsibility, including both operations and capital budgets. Duties also include performing research, conducting a variety of special studies and implementing administrative policies. Functions also include the coordination of the funding program and bid solicitation process in support a \$300M County Courthouse building program. Broward County is the 2nd largest county in the State of Florida with 9 single member districts.

**Brevard County Board of County Commissioners, VIERA, FL 03/2010 – 04/2012****Director – Budget Office**

Provided leadership and direction in strategic management, capital planning, budget and financial management for a \$1.2B county governmental entity that is 10th largest in the State of Florida with 5 single member districts. Responsibilities include strategic and performance management, financial management, budgeting, capital improvement planning, FEMA and stimulus monitoring and implementation, performance measurement, and operational planning for a full service county governmental entity with human services, airport, mass transit, public works, and jail functions in support of a 2,700 employee operation.

**Achievements:**

- Presented a \$1.2B dollar budget to the Board of County Commissioners, citizen groups, media and other stakeholders.
- Led the development and presentation of a Property Assessed Clean Energy (PACE) program for Brevard County, Florida.
- Led the development of a performance management system to include instituting a Balanced Scorecard Management System.
- Updated budget and financial policies to better reflect direction by the Board of County Commissioners and eliminated redundancy.
- Assisted reducing debt obligations and defeasing over \$41M in bonds.
- Assisted in the organization receiving favorable bond ratings from rating agencies.
- Developed first strategy map to communicate the strategic framework and refined organizational performance measures.
- Refined the capital budgeting process to focus on capital planning and the development of a five-year capital improvement program.
- Coordinated with state, municipalities, community redevelopment agencies (CRAs) and other local governments.
- Led the refinement of the budget development process to include public engagement and the streamlining of processes.
- Enhanced the monitoring and reporting of financial information to better communicate financial information.
- Implemented a financial forecasting model to review financial impacts over a multi-year basis.
- Developed solutions to address budget shortfalls the range from \$9.0M to \$30.0M.
- Served as a member on labor negotiation teams for contract negotiations with IAFF(490 employees) and LIUNA (668 employees).
- Served as Chairman of the Deferred Compensation Investment Committee with total plan assets of \$61M for 1,900 employees.
- Served on selection committee and contract negotiation teams to purchase services for the organization.
- Assisted in developing community outreach programs, responded to media inquiries and worked on legislative initiatives.

**ORANGE COUNTY CLERK OF THE COURTS, ORLANDO, FL 06/2003 – 03/2010****Support Services Administrator**

Provided leadership and direction to 43 employees in developing and managing a \$47M annual operating and capital budget, processing of \$222M in cash receipts, purchasing, implementing operational and performance excellence initiatives, developing workforce management strategies for a 600 employee operation, and facilitating strategic, performance measurement, financial and operational planning.

**Achievements:**

- Awarded the Florida Governor's Sterling Award in 2008, 2009 and 2010.
- Developed collection strategy resulting in an additional \$14.0M of revenue at a ROI of 183%.
- Initiated partnerships with private agency to process over \$4.0M in cash receipts at no cost and savings to the Clerk's Office.
- Implemented new revenue recovery approach resulting in of \$3.0M in additional revenue in the first year.
- Assisted in developing community outreach programs, responded to media inquiries and worked on legislative initiatives.
- Led process improvements and cost savings efforts resulting in more than \$10.2M in direct savings.
- Developed organization's first documented strategic plan, strategy map and performance measurement system.
- Developed, implemented and evaluated methods to address a \$6.8M to \$8.0M revenue shortfall.
- Worked directly with local/state officials, judicial and citizen groups to resolve financial, process and customer service problems.
- Presented budget to the CCOC Executive and Finance Committee for approval, and established open government website.
- Negotiated contracts for performance and technology systems, office supplies, and third party vendors.
- Planned and directed human resources management activities to maximize the strategic use of human resources to include payroll, employee relations, benefits administration, compensation, risk management, training/development, and recruitment/ retention.

**Director of Financial Services**

Provided leadership and direction to 25 employees in developing and managing a \$40M annual operating and capital budget, processing over \$200M in cash receipts, policy/procedures, financial management, analysis and planning, budgeting and forecasting, and developing workforce management strategies for a 553 employee operation.

**Achievements:**

- Implemented e-payment services to gain efficiencies that resulted in savings of \$1.45 to \$1.75 per financial transaction.
- Worked with judicial system stakeholders to include the local/state officials on the implementation of Revision 7 to Article V.
- Presented budgets to Executive and Finance Committee for approval.

- Led processing improvements initiatives and served as Champion of Performance Excellence initiatives.
- Developed cash handling/procurement policies to ensure proper procurement, and handling over \$200M in cash receipts.
- Redesigned revenue recovery process to increase collections by 97%, and established performance measures.
- Implemented HRIS/Financial System to better account for financial, purchasing and human resources activities.
- Negotiated and implemented point-of-sale and electronic portals to process payments of over \$200M in cash receipts.

#### **ORANGE COUNTY BOARD OF COUNTY COMMISSIONERS, ORLANDO, FL 04/1996 – 06/2003**

##### **Assistant to the Director - Orange County Growth Management Department**

Provided leadership and direction to 3 employees in developing and managing a \$100M annual operating and capital budget, financial management and analysis, budget and forecasting, developing workforce management strategies for a 400 employee operation, and strategic, financial and operational planning to support Building Safety, Planning, Code Enforcement, Animal Services, Environmental Protection, Housing & Community Development and Zoning Divisions. Assumed responsibilities of Deputy Director from 6/2000 – 11/2000.

##### **Achievements:**

- Planned and directed human resources management activities to maximize the strategic use of human resources to include payroll, employee relations, benefits administration, compensation, risk management, training/development, and recruitment/ retention.
- Implemented \$3.1M financial and expenditure plan for the Lake Apopka Restoration Act grant to address economic issues, and serve as point-of-contact on media inquires.
- Worked with community non-profit groups and elected officials in executing economic development initiatives for grant funds. Worked on Capital Improvement Element (CIE) to ensure alignment with Comprehensive Plan.
- Optimized financial condition of agency by identifying over \$2.0M in additional revenue and \$1.0M in cost savings for Department.
- Worked with the Enterprise Zones (EZ) and Community Redevelopment Agencies (CRA) along with the Planning Division.
- Presented financial strategies to the Construction Council, Home Builder's Association, and Building Code and Adjustment Board.
- Presented budget to the Board of County Commissioners highlighting strategies, funding and challenges.
- Managed citizen task forces in implementing Holden Heights economic redevelopment and County Public Notification Criteria.
- Led and directed organizational development and process improvement activities.

##### **Public Works Administrator – Orange County Public Works Department**

Provided leadership and direction to 12 employees in developing and managing a \$300M annual operating and \$300M capital budget, financial management and analysis, budgeting and forecasting, developing workforce management strategies for a 584 employee operation, and strategic, financial and operational planning to support Roads & Drainage, Stormwater Management, Traffic Engineering, Development Engineering, Highway Construction, Engineering, and Transportation Planning Divisions.

##### **Achievements:**

- Developed a ten-year (10) financial plan (revenue and expenditures) to fund \$200M in major transportation projects.
- Managed over \$300M capital improvement program and presented financial outlook report to executive leadership.
- Presented budget to executive leadership communicating strategy, funding and challenges.
- Worked on Capital Improvement Element (CIE) to ensure alignment with Comprehensive Plan.
- Worked on Concurrency Management Issues with the Engineering, Traffic Engineering and Highway Construction divisions.
- Served on Impact Fee and Concurrency Management Committees to address funding and concerns by developers.
- Tracked and reported all reimbursable expenditures associated with emergency situations to FEMA.
- Led and directed organizational development and process improvement activities.

##### **Capital Improvements Coordinator / Sr. Mgmt & Budget Analyst – Orange County Office of Management and Budget**

Provided leadership and direction to 3 employees in developing, analyzing and managing various departments for an overall budget total of \$1.7B and a capital budget of \$500M in a 9,000 employee operation. Served as Orange County's Capital Improvement Coordinator with responsibilities in managing and developing a \$500M capital improvement budget and plan, intergovernmental coordination, public affairs, policy development, project management, communications, planning and administrative functions to achieve the established vision, mission and goals of the organization.

##### **Achievements:**

- Created, coordinated and implemented polices regarding the use of over \$1.0M in Community Funds on an annual basis.
- Worked with elected officials and legislative staff in the disseminating information to the community and execution of community projects. Provided program status reports to the Mayor and county commissioners.
- Worked directly with neighborhood organizations in the implementation of community funds.
- Developed policies to manage capital projects and to provide direction on forecasting and executing projects.
- Worked on Capital Improvement Element (CIE) to ensure alignment with Comprehensive Plan.
- Tracked and reported all reimbursable expenditures associated with emergency situations to FEMA.

- Led and directed organizational development and process improvement activities.

## OTHER PROFESSIONAL EXPERIENCE

---

### UNIVERSITY OF PHOENIX, PHOENIX, AZ - 07/2009 - present

#### Aixa College Online Faculty Member

Serve as an online instructor for a course entitled *Critical Thinking*. Students are given the opportunity to analyze and discuss various types of media to determine which sources provide the most reliable information. Topics addressed include the relationship between critical thinking and clear writing, credibility of sources, rhetorical devices, fallacies, unclear or misleading language, and the characteristics of various types of arguments.

### VALENCIA ENTERPRISES, ORLANDO, FL - 07/2009 – 04/2012

#### Adjunct Instructor

Certified Development Dimensions International (DDI) and AchieveGlobal Instructor with a focus on delivering Leadership Development and Customer Service trainings to corporate clients.

#### Achievements:

- Developed customized training course on leadership to include Motivating Others, Working with Teams, and Performance Development.
- Delivered leadership trainings to Orlando International Airport, CHEP, Tax Collector Association, TOHO Water Authority and Orange County Corrections Department.

### SEA WORLD OF FLORIDA, ORLANDO, FLORIDA - 04/1992 - 04/1996

#### Productivity/Business Analyst - Business Analysis Department

Provided leadership, guidance and direction to business units in developing, analyzing and managing a \$500M annual budget in support of a 2,000 employee operation.

#### Achievements:

- Analyzed theme park activity to identify cost containment, process improvements and revenue enhancement opportunities.
- Developed policies, procedures and tools regarding the implementation of Total Quality Management program.
- Developed and monitored workforce, and presented the labor budget to corporate headquarters.
- Conducted labor, process, productivity and time studies to analyze department workflow systems and identify efficiencies.

### UNITED STATES NAVAL RESERVES, ORLANDO, FL - 06/1988 - 07/2008

#### Retired Supply/Logistic Officer – Lieutenant (Veteran)

Provided leadership, guidance and direction to 50 unit members in procurement, supply chain management, inventory, and financial management to support efforts of the Navy's Sailors, ships, squadrons, submarines, and shore stations across the globe. Procured and managed inventories in excess of \$2B and provided financial strategies to utilize resources in a cost effective manner. This worldwide effort required strong leadership, organization, strategic planning skills, understanding of supply chain management systems, and experience in intergovernmental coordination and public affairs.

#### Achievements:

- Recalled to active duty in support of Operation Enduring Freedom in 2007. Served as Logistic Officer and worked with Afghanistan vendors in the procurement and transportation of construction materials to military basis throughout the country.
- Served as Strategic Communication Officer/Public Affairs for the Center for Security Forces for approximately one (1) year.
- Worked directly with media in communicating activities of Navy projects to the community, and wrote and published articles on activities of the Center for Security Forces to highlight activities for the organization.
- Provided financial management, cost containment, transportation, logistical and inventory strategies.

## AWARDS

**Distinguished Budget Award (Orange County BoCC)**, Government Financial Officers Association (GFOA) – 1996 to 1998, **Best in Class Collections Program**, Florida Sterling Council – 2007, **Distinguished Budget Award (Clerk's Office)**, Government Financial Officers Association (GFOA) – 2008, 2009 and 2010, and **Florida Sterling Award for Performance Excellence**, Florida Sterling Council – 2008.

---

**VOLUNTEER ACTIVITIES AND BOARDS**

Orange County UNCF Advisory Council Member, National Forum for Black Public Administrators Mid-Florida Chapter (Pres.-7yrs, member-13yrs), American Society for Public Administrators Central Florida Chapter (Pres.-1yr, VP-1yr, member-5yrs), Society for Human Resources Management (SHRM), International City/County Managers Association(ICMA), Alpha Phi Alpha Fraternity, Inc., Florida Government Financial Officers Association (FGFOA), Government Financial Officers Association (GFOA) Budget Reviewer, Heart of Florida United Way Fund Distribution Committee, Orlando Chamber of Commerce Leadership Alumni –Class #65, Greater Orlando Organizational Development (GOOD) Network, Florida City and County Manager Association (FCCMA), and Orange County Leadership Institute Alumni.

---

Summary of Qualifications

Multi-dimensional leader that prefers situational management and offering 13-years of manger/administrator experience. Skilled in developing budgets along with financial work, personnel policies, capital improvements plans, comprehensive plans, grants, economic development, and using computer programs to make lucid presentations. Proficient at staff support to the governing authority and department heads. Always loyal to decisions even if it is not one that I recommended.

Education

- PhD Program (DPA), George Mason University, Fairfax, Virginia (3-semester of course work)
- Master' Degree (MBA w/honors), Bryant University, Smithfield, Rhode Island
- Bachelor's Degree (BS), University of Notre Dame, Notre Dame, Indiana (Major: Chemistry)

Professional Memberships

- International City/County Managers Association (ICMA)

Professional Overview and Highlighted Accomplishments

**City of Kewaunee, WI, (2,952) 401 Fifth Street, Kewaunee, WI 54216**

**City Administrator, August 26, 2016 – September 30, 2016**

- In this short assignment I complete the 2017 budget for review by the Finance Committee.
- The advertisement for the position as well as my interview was normal as to the authority and requirements of a City Manager/Administration position. However, I quickly recognized I was to be the administrative assistant to the Mayor. I agreed to make the draft of the 2017 budget for the Mayor/Finance Committee prior to my resignation.

**Accessing Your Abilities, Inc., 319 N. Main Street, Kewanee, IL 61443**

**Vice-President of Operations/Personnel Officer June 2007 – January 2011**

- A company that provided adaptive equipment and services to persons with disabilities. The company had three focuses: vehicle modifications, personal equipment such as power wheelchairs and scooters, and home/commercial modifications

**City of Mattoon, Illinois (18,000), 208 S. 19<sup>th</sup> Street, Mattoon, IL 61938**

**Interim City Manager, June 2009 – December 2009**

- Initiated a completed a rewrite of the 1986 Personnel Code (worked with Department Heads) City Council reviewing.
- Recommended significant text changes to the City's zoning ordinance, which was approved by the Zoning Board of Appeals (ZBA) and the Planning Commission – City Council reviewing.
- Drafted and promulgate to several consultants a request for proposals (RFP) to update the City's Comprehensive Plan, last approved in 1986, because of cost expect the update to begin in the following fiscal year
- Presented to the Council a draft, complete re-write of the Animal Ordinance
- Chairman of both the TIF and Revolving Loan Fund Committees

The above work caused a lot of good work on the part of the Department Heads, ZBA, Planning Commission, and the City Council, which is required in order to achieve improved and modern documents.

**City of Streator, Illinois (14,000), 204 S Bloomington Street, Streator, IL 61364**

**City Manager, August 2004 – October 2006**

- Working with the City Council to establish funding for replacement of an interceptor sewer serving 10% of the City
- Revised the City's Zoning Regulations and Personnel Policies
- With the authority of the City Council hired a City Engineer with an assistant and the necessary equipment to make engineering projects more responsive to the needs of the City and to realize an overall cost savings compared to consulting engineering firms
- Established a land/cash ordinance
- Working with the City Council to improve the fiscal security of the general fund (budgets that did not have to use



reserve funds and increased the reserves of the general fund)

- Resolution of a police labor dispute with the contract one year past its renewal date
- Establishing a new TIF district encompassing the downtown area and adjacent properties an immediate benefit was the conversion of a Brownfield site to a large doctors' clinic
- Working with the City Council established a plan and bonding to convert a large "jungle area," of about 12 acres, into a fine recreation area having three baseball fields, a football field, walking and exercise path, and a concession stand. The plan also included replacing the decrepit golf course clubhouse with a modern building and a paved parking lot

**City of Rochelle, Illinois (9,500), 420 N. 6<sup>th</sup> St., Rochelle, Illinois 61068 12/03 - 6/04**  
**Interim Public Works Director, December 2003 – June 2004**

- Combined the City's zoning and sub-division code into a Unified Building Ordinance,
- Updated the requirements for a Planed Unit Development (PUD)
- Established a land/cash fee ordinance

**Carpentersville, Illinois (30,580), 1200 L.W. Besinger, Carpentersville, IL 60110**  
**Interim Village Manager, October 2002 – November 2003**

- Main task was to develop the Villages tax levy and start the budget preparations.
- With 13 residential sub-divisions in progress I quickly became involved in the negotiations with developers to ensure standards were maintained per the municipal codes.
- Budget was in excess of \$50M. In addition to completing the work on the tax levy, I also submitted a complete rewrite of the land-cash ordinance and an Administrative Code that included personnel policies and a Village-wide organization document.
- Significantly, I assisted the City Council in ensuring that proper funding was allocated to the Fire and Police pension funds

**Elwood, Illinois (1,600) Village of Elwood, 201 Mississippi, Elwood, Illinois 60421**  
**First Village Administrator, May 2002 – June 2002**

- Elwood annexed in a 3.3 square mile area of land including the former Joliet Arsenal and a \$970M industrial park just starting.
- A new water treatment plant and wastewater treatment plant were being developed in addition to a 1M gal water tower and a new Village Hall for which I developed the RFQ.

**Brave Industries, Annawan, Illinois, 115 East Front Street, Annawan, Illinois 61234**  
**Vice-President, April 1999 – April 2001**

- Wore the hats of National Sales Manager, Graphics Manager, and Electronic Data Interface Manager. With the death of the founder and CEO of the company, his widow decided to shut down and sell the company to a similar company that was fully staffed.

**Riverdale, Illinois (11,500), Riverdale, Illinois, 157 West 144th. Street, 60827**  
**First Village Administrator, December 1997 – April 1999**

- Full service community, has Chicago on its northern border, and has a minority population in excess of 60%.
- Village is a member of the South Suburban Mayors and Managers -- I served on manager's finance committee
- Daily operation of a municipal corporation with an operational budget in excess of \$12 million and 70 full-time employees -- Riverdale had three TIF Districts and developed a fourth -- it also has an Enterprise Zone.
- Organized Village budget processes, relieving Village Trustees of the routine tasks of budget preparation and administrations, thus allowing them to better formulate Village policy through the budget process.
- In conjunction with the Chief of Police and Fire Chief, develop plans and coordinate with architects and engineers for the construction of a new public safety building with a budget of \$4M.
- Established a Village wide personnel evaluation system and assumed the duties of the Chief Examiner for the Village's Civil Service Commission
- Believe my best achievement for the Village was to recommend to the Mayor a highly qualified minority person to relieve me as Village Administrator -- had a one-month turnover and the transition was very smooth.

**Belvidere, Illinois (17,731), 119 South State Street, Belvidere, Illinois 61008**  
**First City Manager, May 1996 – May 1997.**

- Full-service community and is in the rapidly growing Rockford-Chicago Interstate 90 corridor. Belvidere is the County Seat of Boone County.
- Daily operation of a municipal corporation with an operational budget in excess of \$17 million and 95 FT employees
- Lead city staff in an effort, with a consultant from Madison, to put in place a unique plan for the development of several square miles west of Belvidere that will incorporate residential, environmental, retail, and commercial concerns. The effort will result in nearly doubling the area and population of the City. That effort involved establishing a multi-faceted steering committee and holding several community wide public meeting in a vigorous effort to get public and property owner inputs.
- In conjunction with the Public Works Director developed an eight-mile, \$14.2M road and drainage program for the "older" part of the City -- City Council approved
- Established a Citywide personnel evaluation system
- As Chief Negotiator for the City settled a labor dispute that had been on going for 18 months -- also, settled a four-year contract with firefighter union
- Active participant in "Main Street" Program and served as Chair of the Committee to select the first Main Street Program Manager
- Worked closely with the Boone County Administrator and other elected and appointed officials for the betterment of both units of government. Also, coordinate with other units of local government --Park District, Conservation District, School District, and adjacent cities of Rockford and Cherry Valley.
- Economic Development. Belvidere has an enterprise zone, two TIF districts, and a Land/Cash impact fee ordinance. Worked closely with Growth Dimensions to retain and bring in industrial and commercial enterprises.

**City of Kewanee, Illinois (12,969), City of Kewanee, 200 W.3<sup>rd</sup> Street, Kewanee, Illinois 61443**  
**City Manager, July 1992 – May 1996**

- Daily operation of a municipal corporation with an operational budget in excess of \$11 million and more than 80 full-time and 25 seasonal employees
- Chief negotiator for the City's three municipal unions. Completed negotiations for four three-year contracts with the unions (fire, police, & AFSCME) - two, three year contracts (fire contract and police contract) were signed and in place before their predecessors expired
- During fiscal year 95 government improvements to infrastructure exceeded \$5M, while private capital improvements have exceeded \$14M --a major effort over a three-year period to revitalize the downtown was the replacement of sewer and water lines, a new streetscape, and reconstructed streets
- Implemented a centralized computer accounting and utility billing system along with good direction to staff, a capital improvement program (CIP), enterprise fund accounting, and in house cross-training --leading the City auditors and the State comptroller office to recognize Kewanee as being back on the road of good accounting practices
- Converted a refuse disposal from a landfill operation to a transfer station operation meeting Illinois EPA deadlines and without a bump in service to the citizens
- Initiated a curbside recycling system in Kewanee
- Economic Development ranged from residential construction to industrial expansion for current and new enterprises. Kewanee had a 76% growth in primary industrial jobs
- Grant/Loan reviews and submissions. Kewanee received four grants totaling over \$1.4 M for the improvement of water system and received Illinois EPA approval of a sewer facilities plan which lead to a low interest loan of \$3.5M to improve sanitary sewer collection system
- Chief Examiner for Civil Service Commission and assistant to the City's Fire and Police Commission
- Author 90% of all City ordinances and resolutions, coordinated the re-codification of the City Code, and completed and had approved by the City Council a separate City Administrative Code, which includes personnel policies and the City's administrative organization

**Village of Carlisle, Ohio (4,950) Carlisle, Ohio, 760 W. Central Ave., Carlisle, Ohio 45005**

**First Village Manager, March 1991 – July 1992**

- Very successful record on receiving grants from the State of Ohio for road repairs, from Community Development Block Grant program and from the State of Ohio for the development of water programs
- Successfully worked with a local developer and County government to start a 50 unit residential development making maximum use of tax incentive programs at the Village and County levels
- First appointed manager after citizens of Carlisle established a Council-Manager charter per the State of Ohio statutes
- I Established and maintained excellent intergovernmental relationships with Montgomery and Warren County governments and with the City of Franklin and the township.

Summary of Naval Service for Commander John D. Kolata, USN (Ret)

Graduating from High School and not having the resources for college I enlisted in the U.S. Navy. After a years service as an enlisted man I was selected for an officer program and received a Navy scholarship to the University of Notre Dame. Upon graduation with a BS I was commissioned as an Ensign in the U.S. Navy. My career path was 12-years in submarines, shipboard tours on a cruiser and a destroyer with shore tours in various ports and also two years in London England. Because of my Naval Service I do not require health benefits for my wife and myself. I estimate this represents a cost avoidance for the municipality of between \$10,000 and \$15,000 per year

The highlight of my career was as the Commanding Officer of the USS Manitowoc (LST-1180) with officers and crew of 600. During my command tour I was in charge of the US Marines amphibious assault from my ship on to the beach of Grenada. Also I brought in on time and 21% below budget my ship's \$8.1 million, six month, major repair overhaul, with a first time contractor. Prior to my command tour I served as a supply officer, weapons, engineering officer, and executive officer. My post command tour was as the Director of Administration at the Naval Complex in New Port, Rhode Island.

- City and Business Manager for the Naval Base complex at Newport, Rhode Island as Director for Administration -- responsible for intergovernmental relations with local and state government personnel in the Newport, RI area. In this large complex I lead and managed over 360 people through Department Heads. Included in the functions were:
  - Police Department (43 members) & Fire Department (66 members at 4 stations)
  - Parks, Recreation, and Quality of Life program including a swimming pool, gymnasium -- 24-lane bowling alley, an ocean beach, small boat marina, and 8 athletic fields
  - Public housing consisting of twelve multi-story hotels and several hundred single-family housing units;
  - Centralized accounting and budgeting, including personnel, with a division staff of eight
  - Civil disaster preparedness and mobilization-planning effort was proved successful when the complex was hit by a hurricane, but maintained utility and health services
  - Co-developed and managed the initiation of an Information Resources Management (IRM) System at the Naval Complex in Newport, Rhode Island. System designed to link micro, mini and mainframe computers and satisfies the needs of batch and decentralized users.

## REFERENCES

Mr. Wayne Becker  
Former City Council Member  
617 S Chestnut Street  
Kewanee, Illinois 61443  
H309/853-8783

Honorable Jimmie Lansford  
Mayor of Streator, IL  
204 S. Bloomington Street  
Streator, Illinois 61364  
(City Hall) 815/672-2517

Mr. William Stewart  
Former City Attorney/Retired Practicing Attorney  
522 S Tremont St  
Kewanee, Illinois 61443  
H309/853-8809 W309/853-4878

Mr. Kip Spear  
Former Employee & Former City Manager  
507 E. McClure St  
Kewanee, Illinois 61443  
309/312-1833

Mr. Michael Yaklich  
City Council Member of Kewanee, IL  
701 Morton Avenue  
Kewanee, IL 61443  
309/853-5613  
Alt 309/854-3396 (Mrs. Melody Yaklich)

### Comments on Two Municipal Positions Held

The reason I am including this section is to address any questions you may have about my two short municipal positions.

- City of Belvidere, City Manager, [5/96 - 5/97]. Belvidere's City Council used an ordinance to establish a City Manager. In November of 1996 a referendum was held to establish the Managerial form of government in Belvidere. The referendum was defeated; however, the City Council ordinance remained in effect. It was obviously very awkward to be a City Manager in a municipality where a majority of the citizens voted not to have the Managerial form of government. In the selection process for City Manager I was not made aware that in the month before I was hired petitions were submitted to put the Managerial form of government on the November ballot. In addition, citizens who were opposed to the managerial form of government circulated the petitions. The question on the ballot was placed in such a manner that, if adopted, would have not only changed the form of government, but also would have reduced the council from 10 to 4 members and would have elected council members all at large instead of from wards. Few citizens, even those supporting professional management, could not support the at large elections and the drastic reduction of council members.

Belvidere is an excellent community and I established excellent rapport with several community leaders. In hindsight, had I known of this political situation in Belvidere I would not have accepted the position - unfortunately I was ignorant of the situation. The sitting Mayor was defeated and I resigned effective with the end of his term.

- Village of Elwood, Village Administrator [5/02 - 6/02]. Obviously, neither I, the Mayor and Trustees of the Village anticipated this short appointment. The Mayor and the Village Board went through, what I considered a long and through process to select me as their first Village Administrator from a large field of candidates. I was not allowed to attend the executive session in which my contract termination was discussed. In the open session there was just a motion and second with no discussion, thus I am not able to comment on the actual reason why I was terminated - I was not told by the Village Board.

I can state unequivocally that I did not have any illegal or ethical violation that lead to my contract being cancelled.

I must admit I was very shocked about my contract being terminated. I received no advance counseling or comments about my performance by the Village Board. I was brought into the Mayor's Office with the Village Attorney and was told that the Mayor was going to recommend to the Council that my contract be ended. However an impact may have been that I did not allow the Mayor's son to wear piercings while on duty in the Public Works Department and he had to come to work every day unless excused. Also I did not comply with the Mayor's request to employ his juvenile 15-year old daughter in a full-time position for which there was no budget authority nor a vacancy in the department.

I believe I have demonstrated the ability to keep elected official informed of events that are occurring within their jurisdiction. An important aspect of my job is to recommend well thought out and lucid policies and goals, along with various options and then, with loyalty, to abide by the decisions that the governing authorities puts into effect.

# Ben Newhouse

1111 N. Poplar Fork Road, Hurricane, West Virginia 25526  
(304) 741-4878      bennewhouse0000@outlook.com

---

## PROFESSIONAL WORK EXPERIENCE

### City of Hurricane 2005-Present

In my current position as City Manager for the City of Hurricane, West Virginia, I oversee various departments including police, administration, maintenance, street, water, wastewater, storm water, code enforcement, housing inspection and demolition. The city has a population of approximately 7,000 residents and approximately 300 businesses. I oversee a \$10 million per year budget with 80 employees. Some of my responsibilities include the oversight and operation of the wastewater and water plants, personnel/human resources, finances, budgeting, forecasting, insurance, equipment, loss prevention, grant writing, and fund raising. I work in unison with many other agencies to provide resources to various residents such as housing rehabilitation, recreation, education, economic and community growth. My goal is to advocate for a stronger community through family and business development by understanding and utilizing all assets to enhance our standard of living. Community benchmarks and objectives are developed to ensure growth and stability throughout the City. Community and economic initiatives are developed to heighten awareness, viability and sustainability in the region.

To quantify my success at the City, the following statistics have been accomplished due to my ability to secure grant funds, financing and refinancing equipment and improvements and to evaluate service related contracts to provide more income to the City:

1. **Housing rehabilitation**-Over 300 homes have been rehabilitation in the community by securing \$160,000 in grant funds, which in turn reinvested more than \$2 million to local vendors and residents. Vendors benefitted from the workcamps with all material, supplies and other needs purchased locally. Workers resided in the community from across the United States to fix structural problems for homes across the region. Significant investment has been made to many seniors, low-income and handicapped individuals with the free housing rehabilitation.
2. **Grants**-Many grants have been secured to purchase equipment and improvements such as energy efficiency, police equipment, computers/laptops and community enhancements. Approximately, \$200,000 has been secured for lighting improvements, solar panels, and external insulating finishing system (EIFS). Funding in the amount of \$100,000 has been granted for police vests, shotguns, and in-car cameras and computers. Recreation funding was also gained during my tenure with over \$1 million provided from various agencies. Various projects include sidewalks (\$900,000) and trail development at the city park (\$100,000).

3. **Contractual**-What I consider to be one of my greatest accomplishments is the ability to identify, evaluate and resolve service contracts to benefit the City and its workers. Hiring local contractors, vendors and employees has always been a top priority. Coupling with the hiring of local companies and residents, savings were gained by ensuring reliability and maintaining a high level of consistency within the workplace. It is estimated that over \$500,000 has been saved by evaluating competitors and price to strengthen the City's financial status while providing enhanced service for our employees and residents.
  
4. **Financial**-Approximately \$1 million has been saved by the City by refinancing projects such as Main Street building and improvements, city vehicles and water/wastewater loans/bonds. All financial instruments have been evaluated and restructured to apply to fiscal budgets and garner savings for the City. Many loans were consolidated to give terms that would provide greater flexibility for various departments. Having flexibility is crucial based upon varying revenues and expenses that could be experienced in future years.
  
5. **Community Development**-Several projects have been established and completed during my tenure. A few projects that have been significant and been fortunate to obtain grant funding has been the Sprayground (\$250,000) and the new bridge (\$350,000) that are located at the Hurricane City Park. The sprayground has provided a free water park for children in the community for the past 5 years. Approximately 100,000 children and family members have utilized the sprayground in the past five years. The new bridge was recently constructed to provide a new two-lane access into the city park. A new pedestrian bridge is planned for the Spring of 2017 to accompany the new bridge.

**Upper Kanawha Valley Enterprise Community (UKVEC)  
1998-2005**

After serving as Community Development Specialist with the West Virginia Development Office, I was hired as the Executive Director of the Upper Kanawha Valley Enterprise Community (UKVEC). Our mission was to assist with community and economic development efforts to an area that had a federal poverty rate of 25.1%. Several projects were initiated and completed by the UKVEC, but the development of the business incubator served as a pivotal accomplishment to retain and expand jobs in eastern Kanawha and Fayette Counties. The incubator was a substantial achievement due to its creation of new jobs, community connectivity, and available training space. I attended many trade shows to illustrate West Virginia and attract businesses to the state as well. I worked in conjunction with the West Virginia Development Office, Upper Kanawha Valley Economic Development Corporation, Charleston Area Alliance and the West Virginia University Institute of Technology. This role also offered me the opportunity to rehabilitate 700 homes at no cost for area residents, \$1 Home Purchases with Habitat for Humanity and demolition of blighted buildings were some of the other projects our

organization worked collaboratively with other non-profits in the area. Some of the other community agencies that I worked with in the Upper Kanawha Valley included Cabin Creek Health Clinic, Starting Points, Kimberly Community Center, Southern Appalachian Labor School, East Bank Community Cupboard, Cabin Creek and Lower Paint Creek Watershed Associations.

Following are some of the funding secured for various projects:

1. Business incubator-\$1.5 million was secured for the business incubator in Chelyan that established offices for small businesses, entrepreneurs and other non-profits. Over 50 jobs were provided through the use of the incubator. Various community programs and meeting space were provided from the restoration of the former elementary school into an incubator.
2. Approximately 200 computers were refurbished and distributed to low-income residents to strengthen their family's technology in their homes for educational attainment. Computers were provided by American Electric Power (AEP) and improved with new software and hardware.
3. Through Group and REACH Workcamps, 700 homes were rehabilitated for an investment of almost \$3 million in the Upper Kanawha Valley. Again, the housing rehabilitation was provided at no charge to residents. The initiative behind the many weeks of workcamps was to orient out-of-state visitors with the community with the hope that they would return to West Virginia for tourism or other purposes.

**West Virginia Development Office (WVDO)**

**-U.S. Housing and Urban Development (SCBG) (1992-94)**

**-U.S. Department of Energy (1994-96)**

**-Appalachian Regional Commission (ARC) (1996-98)**

**1992-1998**

After graduating from West Virginia Institute of Technology with a Bachelor of Science in Accounting, I worked for the West Virginia Development Office (WVDO) in three divisions. Initially, I started with the Energy Efficiency Office, progressed to the Small Cities Block Grant office, and concluded with the Appalachian Regional Commission. For almost seven years, I was with the West Virginia Development Office. I worked extensively with other economic and community development agencies in many areas of West Virginia. These agencies include public service districts, counties, regional councils, regional development authorities, cities, and businesses. Some of the projects I was involved in included small business expansion, energy efficiency, alternative fuels, infrastructure, education, and health care.



## EDUCATION

**Masters in Strategic Leadership** (2005). Mountain State University - Beckley, WV

**Bachelors in Accounting with a Minor in Business and Computer Management** (1992).  
West Virginia University Institute of Technology – Montgomery, WV

**Community Development Certificate** (1996). Central Arkansas University – Conway, AR

**Economic Development Certificate** (1994). University of Kentucky – Lexington, KY

## PROFESSIONAL AFFILIATIONS

Habitat for Humanity

Rebuilding Together

Cabin Creek Quilts

Charleston Area Alliance

United Way-Putnam County Committee

Putnam County Chamber of Commerce-Education Committee

Putnam County Solid Waste Authority

Hatfield-McCoy Recreational Trail Authority

Natural Capital Investment Fund (NCIF) - Freshwater Institute

EnAct

BridgeValley Foundation

Hurricane Development Authority

United Way's Program Services Advisory Committee

Upper Kanawha Valley Starting Points

Regional Intergovernmental Council

Arts in Action

BB&T Community Reinvestment Act Advisory Board

Generation Putnam

Micro Enterprise Development Association (MEDA)

## VOLUNTEER INVOLVEMENT

**Coach**-For the past 25 years, I've coached various athletic teams including; baseball, flag football, high school and middle school soccer, girls volleyball and track

**Portfolio**-Assisted by reviewing resumes and portfolios for area high school students to better prepare for a collegiate career by assessing their personal skills during an interview process. Additional assessment was provided to the student to determine their financial aid, curriculum and schedule to assist with future success in a college setting.

**OBJECTIVE:** To be hired as the next City Manager for the City of Winter Springs, Florida.

**SUMMARY:** Highly accomplished manager with twenty-two (22) years of managing experience in local government with expertise in the following areas: Growth Management, Consensus Builder, Intergovernmental Management, Team Builder, Change Agent, Economic Development, Local Government Budgets, Communications, and Strategic Planning. Uniquely skilled at building relationships, resolving issues, and resolving dispute resolution, providing outstanding customer service, and leading teams to deliver optimum results.

**CURRENT WORK EXPERIENCE:**

**York County, S.C. (1,200 Employees) (6 South Congress St, York, S.C. 20745, 803-684-8511, Salary: \$194,300)  
(County Rating of Aaa)**

**09/13 – Present:** County Manager: Provide for the daily oversight and long range planning of York County administration and operations. (Administration, Human Resources, Procurement, Economic Development, Public Works, Engineering, Finance, Assessor, Auditor are direct reports.)

Accomplishments:

- York County was recognized by Governor Henry McMaster as one of the best in the State in reference to Economic Development and Road improvements.
- Recognized, by media, for the last two years as best in the nation for Economic Development for a county our size.
- Fiscally Sound, one of the stronger budgets (AA+) in the State as briefed by our Auditors.
- \$115 million worth on-going building construction on time and on budget.
- \$90 million worth of on-going road construction on time and on budget.
- Completed and implementing the York County Comprehensive Plan.

**City of Augusta, GA (2,700 FTE of which I was responsible for 1,150, Budget responsibility was \$180,000,000.)  
(Salary \$118,500.00) (530 Green St, Augusta, Ga 30907, 706-821-2400)**

**03/11 – 09/13** Deputy Administrator: Supervised the day-to-day operations of the Engineering (Roads, Traffic, Construction, and Engineering), Public Safety (Corrections, Fire Department, 911, and Animal Services), Recreation (Recreation, Building Maintenance, and Cemetery), Environmental Services, and Utilities (Water, Sewer, and Infrastructure) Departments.

Accomplishments:

- Identified and fixed violations with the E-911 Department in reference to GCIC.
- As Interim Director, we reorganized the Augusta Fire Department from three to two Battalions to reduce overtime costs, improved processes, created a "Fire Team", and increased moral. Reorganized the department and created and implemented new SOPs.
- As Interim Director for the Recreation Department we reorganized the timecard process.
- As Interim Director of the H.R. Department we reorganized the whole department to improve all processes and stop employee complaints.

- City/County Liaison to Housing and Development. Worked with staff in the areas of Community Housing Development Organization (CHUDO) and Home Investment Partnership Program to expand the supply of decent and affordable housing for low and very low income citizens. In addition, our goal was to create and strengthen partnerships among all levels of government and the private sector, including for-profit and nonprofit organizations, to produce and/or manage affordable housing.

***City of St. Marys, Georgia (418 Osborne St., St. Marys, GA 31558, 912-510-4000)***

**04/04 – 03/2011**

**City Manager:** Managed the daily operations of the City by serving as a liaison between the Mayor, Council, and the public.

**Accomplishments:**

- Acting Chief of Police for my first four months of employment.
- Brought together the governments, within the County, and we, as a team, created a Service Delivery Plan without hiring Consultants.
- Reduced FTE's from 199 to 157 without layoffs.
- Upgraded the Point Peter WWTP from .8 MGD to 4 MGD in approximately 36 months which was under budget and under schedule.

***Habersham County Board of Commissioners (555 Monroe, St., Unit 20, Clarkesville, GA 30523, 706-839-0200)***

**12/02 – 04/04**

**County Manager:** Managed the daily operations of the County.

**Accomplishments:**

- First manager under the Commission/Manager form of Government.
- Streamlined processes to improve productivity.
- Developed and implemented long range plans and attached them to the budget.
- Restructured the Fire Department making it more responsive to citizen needs.

***Camden County Board of Commissioners (200 E. 4<sup>th</sup> St., PO Box 99, Woodbine, GA 31569, 912-576-5601)***

**11/01-12/02**

**Assistant County Administrator:** I supervised the work of personnel involved in general services, to include Administrative, Animal Control, and Human Resources. Media representative.

***Liberty County Board of Commissioner: (RM 201, Courthouse Annex, 112N. Main St., Hinesville, GA 31310, 912-876-2164)***

**12/99-11/01**

**Assistant County Administrator:** Directed and administered purchasing, fixed assets, and computer operations of the County. I administered the County's pay plan and performance appraisal system. Media representative.

*City of Savannah (P.O. Box 1027, 2 E. Bay St., Savannah, GA 31401, 706-651-6415)*

**03/96-12/99**      Special Projects Manager: (Bureau of Public Development) I conducted studies of management and/or budgetary issues to include performance assessment, staffing analysis, cost benefit analysis, and determining performance measures for Bureau and City wide service areas.

Management Analyst: Performed professional analytical work in identifying, defining, analyzing, and recommending solutions to a variety of management systems and/or budgeting problems and to do related work.

*United States Air Force: (Total Time Active Duty, 20 Years) (D.D. Fm. 214 Available)*

**02/76-02/96**      Superintendent of Personnel/Resource Management (Manpower Craftsman)  
Assistant Superintendent of Law Enforcement (Security Craftsman)

**QUALIFICATIONS:**

**Education:**      1995    **MPA, City University, Washington**  
                         1992    B.S. Vocational Education Studies, Southern Illinois University  
                         1991    A.S. Personnel Administration, Community College of the Air Force  
                         1991    A.S. Criminal Justice, Community College of the Air Force

**Accomplishments:**    2015    Completed the South Carolina Economic Development Institute  
                                 2012    **Certified Mediator, UGA and Gatlin Education Services**  
                                 2007    Graduated the UGA Planning Institute  
                                 2007    **Nims (Incident Command System) Training: 100, 200, 402, 700, and 800**  
                                 2007    **Introductory Governmental Accounting, University of Georgia**  
                                 2006    **ICMA Credentialed Manager** (Still Credentialed)  
                                 2005    County Commissions Training Program (Certified County Official)  
                                 2005    Recovery from Disaster/Hurricane Conference  
                                 2004    Regional Economic and Leadership Development  
                                 1999    Certificate of Public Management, University of Georgia

**References:**

Robert Winkler, York County Council, 803-230-7836, [Robert.winkler@yorkcountygov.com](mailto:Robert.winkler@yorkcountygov.com)  
David Harmon, York County Deputy Manager, 803-242-4443, [David.Harmon@yorkcountygov.com](mailto:David.Harmon@yorkcountygov.com)  
Tommy Pope, Representative, 803-984-6616, [tpope@elrodpope.com](mailto:tpope@elrodpope.com)  
Rick Jiran, Duke Energy, 803-628-8520, [Rick.Jiran@duke-energy.com](mailto:Rick.Jiran@duke-energy.com)  
Kevin Tolson, York County Sheriff, 803-371-0707, [kevin.tolson@yorkcountygov.com](mailto:kevin.tolson@yorkcountygov.com)

**DAVID A. STROHL, ICMA-CM**  
800 North Oregon Avenue  
Morton, Illinois 61550-3026  
309-253-3923 (Mobile)  
dastrohl@comcast.net

---

## **PROFESSIONAL EXPERIENCE**

**Village Administrator, Village of Forsyth, Illinois**

**January, 2014 - Present**

Chief Administrative Officer responsible to the Village President and six-member Board of Trustees for the management of the municipal operations of a full-service, non-home rule municipality operating under the mayor-council form of government.

### General Administration And Management

- Assist the Village President in her role as Local Liquor Control Commissioner administer and enforce state and local liquor codes within the corporate limits of the Village.
- Develop and implement plans, policies, procedures, and programs in many areas of municipal operations.
- Draft ordinances and resolutions.
- Initiated the posting of the meeting packets for meetings of the Board of Trustees on the Village's World Wide Web site in order to promote openness and transparency.
- Initiated the practice of having no open liquor licenses in order provide greater control by the Board of Trustees over potential new licensed establishments.
- Initiated, coordinated, and participated in strategic planning activities and developed resulting strategic plan document. Responsible for implementing strategic plan.
- Led the process for the Village's participation in a County-wide mass/public notification system, working in a cooperative regional manner to obtain emergency notification capabilities to alert residents to emergency situations while achieving significant cost savings.
- Make policy and programmatic recommendations to the Village President and Board of Trustees.
- Manage and coordinate the maintenance of the Village's information technology (IT) infrastructure and telephone system.
- Manage and coordinate the Village's municipal electric aggregation program.
- Perform community, intergovernmental, and media relations activities.
- Prepare agendas and meeting packets for meetings of the Board of Trustees.
- Provide general administrative assistance and support to the Village President and Board of Trustees.
- Provide research and analysis for the Village President and Board of Trustees on policy and programmatic matters.
- Respond to citizen complaints and inquiries.
- Responsible for the administration and oversight of the Village's cable television, electric, natural gas, and telephone franchise agreements.
- Responsible for the administration and oversight of the Village's intergovernmental agreement with the Macon County Sheriff's Office for the provision of police services. Negotiated renewal of police services agreement.
- Responsible for the administration and oversight of the Village's municipal electric aggregation program.
- Supervise the maintenance of the Village's World Wide Web site.
- Supervise the production and distribution of the Village newsletter.

### Budgeting And Financial Management

- Initiated a review of practices regarding the investment of idle cash in order to ensure effective cash management.
- Initiated the conversion of the Village's fiscal year from May 1-April 30 to January 1-December 31 in order to better align the fiscal year with numerous events and processes.
- Initiated the establishment of a special revenue fund to account for the tax levied and imposed by the Village upon the use and privilege of renting a hotel or motel room within the Village in order to promote accountability for such revenue.
- Initiated the outsourcing of printing and mailing utility bills, thereby reducing costs and allowing staff to perform other duties.
- Manage and supervise the accounts payable, accounts receivable, and payroll functions.
- Manage and supervise utility billing, collections, and customer service operations for the Village's wastewater and water utilities. Monthly billing to 1,000+ customers.
- Responsible for the preparation and administration of the annual operating and capital budgets, as well as the preparation of the tax levy ordinance.
- Serve as Budget Officer.

Community And Economic Development

- Created the position of Community and Economic Development Coordinator and hired the Village's first community and economic development professional in order to better address community and economic development issues.
- Created the position of Event Coordinator in order to develop, promote, and conduct community activities and events that contribute to and enhance the quality of life of residents and that contribute to and enhance a sense of community among residents.
- Initiated a review of and revisions to code enforcement procedures and the creation of the position of Code Enforcement Officer in order to better address code enforcement issues.
- Initiated a review of and revisions to land use regulations to ensure effectiveness and practicality of such regulations.
- Initiated and led the process of establishing a Tax Increment Finance (TIF) District in order to create a funding mechanism for commercial and residential development within the Village.
- Initiated the acquisition of a geographic information system (GIS).
- Initiated the requirement that the Village Attorney attend the regular meetings of the Planning and Zoning Commission each month in order to improve the conduct of business at the regular meetings of the Planning and Zoning Commission.
- Led the process for the development of zoning regulations for medical marijuana facilities.
- Led the process for the Village's inclusion in a proposed new multi-jurisdictional enterprise zone.
- Manage the Village's tourism program, with the goal of promoting tourism and attracting nonresident overnight visitors. Manage the Village's tourism grant program, which provides funding each year from the Village's hotel/motel tax revenues to local organizations to promote activities and events within the Village and the surrounding area that promote tourism and attract nonresident overnight visitors. Developed policies and procedures regarding the operation of the Village's tourism grant program in order to provide for a more orderly and objective decision-making process.
- Serve as Plat Officer.
- Serve as Zoning Officer/Zoning Official.
- Serve on the Board of Directors of the Economic Development Corporation of Decatur and Macon County.
- Serve on the Enterprise Zone Advisory Board.
- Serve on the Village's Community Center Committee examining the issue of potentially building and operating a community center.
- Served on the Community Marketing Governance Committee, overseeing an area-wide branding and marketing initiative.

Human Resource/Personnel Management

- Manage all aspects of the Village's human resource/personnel system and perform various human resource/personnel functions, including:
  - Administering employee benefits.
  - Administering the Village's drug and alcohol testing program.
  - Administering the Village's pay plan.
  - Developing and implementing personnel policies and procedures.
  - Ensuring compliance with applicable laws and regulations.
  - Performing labor relations activities.
  - Preparing and revising position descriptions.
  - Serving as a member of the Village's collective bargaining team.
  - Serving as ADA Coordinator.
- Initiated and implemented a Section 125 (Premium-Only) plan.
- Initiated and implemented the increasing of the annual work-hour threshold for participation in the Illinois Municipal Retirement Fund (IMRF) in an effort to decrease the number of part-time employees eligible for participation, thereby lessening the labor costs of the Village.
- Updated a variety of Village human resource/personnel policies and procedures and employee benefits.

Public Works

- Initiated a review of and revisions to the Village's subdivision construction standards and practices in order to ensure that development is constructed and infrastructure is installed so as to last a reasonable amount of time in order to save taxpayers' money in the future.
- Initiated the development of regulations regarding the installation of personal wireless service facilities in Village rights-of-way and on private property.
- Initiated the performance of a street pavement assessment to provide objective evaluation of the Village's street infrastructure to assist in the capital planning process.

- Initiated the practice of conducting open houses for public works projects in order to facilitate better communication between the Village and property owners and residents affected by major public works projects.
- Initiated the practice of performing design work for public works projects during one calendar year and construction the following calendar year in order to allow for the orderly and timely completion of public works projects.
- Led the process for the Village's participation in a regional effort to protect the Mahomet Aquifer from contamination from a proposed hazardous waste disposal site.
- Manage and coordinate the Village's municipal electric supply contract for the supply of electricity to Village facilities.
- Serve on the Policy Committee and the Technical Committee of the Decatur Urbanized Area Transportation Study (DUATS).

#### Risk Management

- Manage and supervise all aspects of the Village's risk management program, including the administration of the Village's liability, property, and workers' compensation insurance programs and the administration of claims.

#### **Interim City Administrator, City of La Grange, Missouri**

**July, 2013 - January, 2014**

Chief Administrative Officer responsible to the Mayor and six-member City Council for the management of the municipal operations of a full-service, Special Charter municipality operating under the mayor-council form of government.

- Conducted a review of existing bank and investment accounts in order to provide for effective cash management practices.
- Implemented weekly staff meetings in order to facilitate management of municipal operations and communication and cooperation across departmental boundaries.
- Initiated and led the process of reviewing City records in order to identify records appropriate and eligible for destruction and records required to be retained according to record retention requirements, organizing those records required to be retained, and destroying those records appropriate and eligible for destruction.
- Initiated the creation of a formal order of business for regular meetings of the City Council in order to improve the conduct of business at regular meetings of the City Council.
- Initiated the creation of a formal policy regarding public participation at meetings of the City Council in order to improve the conduct of business at meetings of the City Council.
- Initiated the preparation of monthly budget-to-actual reports and the distribution of those monthly budget-to-actual reports to the Mayor and City Council and to Department Heads in order to improve financial oversight by the Mayor and City Council and by Department Heads.
- Initiated the requirement that the City Attorney and Department Heads attend both regular meetings of the City Council each month in order to improve the conduct of business at regular meetings of the City Council.
- Led the process of evaluating the appropriateness of converting the City's health insurance plan from a fully-insured plan to a self-funded plan.
- Led the process of soliciting and evaluating proposals for electronic mail and World Wide Web site services. Led the process of migrating the City's electronic mail and World Wide Web site to new service providers.

#### **In Transition (As a result of previous position being eliminated)**

**January, 2012 - July, 2013**

#### **Business Manager, Village of Morton, Illinois**

**March, 2000 - December, 2011**

Chief Administrative Officer responsible to the Village President and six-member Board of Trustees for the management of the administrative operations of a full-service, non-home rule municipality operating under the mayor-council form of government.

#### General Administration And Management

- Assisted in the negotiation of the Village's cable television, electric, and natural gas franchise agreements. Responsible for the administration and oversight of the Village's cable television, electric, natural gas, and telephone franchise agreements.
- Assisted the Village President in his role as Local Liquor Control Commissioner administer and enforce state and local liquor codes within the corporate limits of the Village.
- Coordinated the Village's municipal electric aggregation effort.
- Developed and implemented plans, policies, procedures, and programs in many areas of municipal operations.
- Drafted ordinances and resolutions.



- Initiated and developed the Village's first official World Wide Web site. Supervised the maintenance of the Village's World Wide Web site.
- Initiated and led process of implementing Google Apps as the Village's electronic mail service provider, thereby providing greater functionality at a lower cost.
- Initiated the adoption of an administrative policies and procedures manual.
- Initiated, coordinated, and participated in strategic planning activities.
- Made policy and programmatic recommendations to the Village President and Board of Trustees.
- Managed and coordinated the maintenance of the Village's information technology (IT) infrastructure and telephone system.
- Managed the Village's cable television government access channel.
- Performed community, intergovernmental, and media relations activities.
- Prepared a successfully-funded competitive grant application for a grant to replace the windows at Village Hall with energy efficient windows. Administered the grant upon its being awarded.
- Prepared agendas and meeting packets for meetings of the Board of Trustees.
- Provided general administrative assistance and support to the Village President and Board of Trustees.
- Provided research and analysis for the Village President and Board of Trustees on policy and programmatic matters.
- Responded to citizen complaints and inquiries.
- Responsible for the administration and oversight of the Village's residential waste collection and recycling contract.

#### Budgeting And Financial Management

- Improved the collection of delinquent utility accounts by revising policies and procedures regarding delinquent utility accounts.
- Initiated and implemented modifications to the budget document in order to improve readability and usability.
- Initiated and led process to replace the Village's financial management software and related computer hardware.
- Managed and supervised the accounts payable, accounts receivable, and payroll functions.
- Managed and supervised utility billing, collections, and customer service operations for the Village's natural gas, storm water, wastewater, and water utilities. Monthly billing to 6,000+ customers.
- Responsible for the preparation and administration of the annual operating and capital budgets, as well as the preparation of the annual appropriation ordinance and the tax levy ordinance.

#### Community And Economic Development

- Coordinated special census project which resulted in an additional \$175,000+ in state-shared revenues per year.
- Developed a building façade improvement grant program to provide financial assistance for the rehabilitation of the exterior of commercial buildings located within the Morton Business District to promote commercial redevelopment activities within the Morton Business District, to improve the aesthetics of commercial buildings located within the Morton Business District, and to enhance the overall quality of life for residents of the community.
- Developed a revolving loan fund program to make monies available to businesses located within the Morton Business District to provide financial assistance for the purchase of fixed assets and for the acquisition of or improvements to commercial real estate properties located within the Morton Business District.
- Led effort to create a Business District to facilitate and provide funding for community and economic development and redevelopment activities. Served on the Business District Development and Redevelopment Commission.
- Managed the Village's tourism program, with the goal of promoting tourism and attracting nonresident overnight visitors, and supervised the Director of Tourism. Managed the Village's tourism grant program, which provided more than \$100,000 in funding each year from the Village's hotel/motel tax revenues to local organizations to promote activities within the Village that promote tourism and attract nonresident overnight visitors.
- Served as Chair of the Downtown Development Action Team of the Morton Economic Development Council. Led effort to engage a consulting firm to assist in the development of a Downtown Development Plan to guide downtown redevelopment efforts. Led effort to develop and adopt Downtown Development Plan.
- Served as Chair of the Retail Recruitment Action Team of the Morton Economic Development Council. Initiated and led efforts to conduct a regional retail study involving several area communities intended to identify appropriate retailers and restaurants on which to focus attraction efforts, working in a cooperative regional manner to improve the retail environment of the area while achieving significant cost savings for the communities involved.

- Served as Enterprise Zone Administrator of the Morton Enterprise Zone, performing such duties as:
  - Assisting businesses in obtaining incentives from the State of Illinois.
  - Handling inquiries regarding incentives.
  - Providing periodic reports to the Illinois Department of Commerce and Economic Opportunity.
  - Verifying the location of properties within the Morton Enterprise Zone.
- Served on the Board of Directors of the Morton Economic Development Council.
- Served on the Comprehensive Plan Committee which reviewed and updated the Village's Comprehensive Plan. Served on the Economic Development Subcommittee of the Comprehensive Plan Committee. Wrote the core of the Economic Development Section of the Comprehensive Plan.
- Served on the EDGE (Economic Development And Growth Experts) Group, an advisory body to The Economic Development Council For Central Illinois.
- Served on the Peoria Area Convention and Visitors Bureau Advisory Board.

#### Human Resource/Personnel Management

- Managed all aspects of the Village's human resource/personnel system and performed various human resource/personnel functions, including:
  - Administering employee benefits (including the Village's self-funded health insurance plan and Section 457 deferred compensation plan).
  - Administering the Village's drug and alcohol testing program.
  - Administering the Village's pay plan.
  - Developing and conducting compensation studies and surveys.
  - Developing and implementing personnel policies and procedures.
  - Ensuring compliance with applicable laws and regulations.
  - In-processing and out-processing of employees.
  - Performing job analyses and preparing position descriptions.
  - Serving as a member of the Village's collective bargaining team (two collective bargaining units).
  - Serving as ADA Coordinator.
  - Serving as Illinois Municipal Retirement Fund (IMRF) Authorized Agent.
- Developed the Village's first official position descriptions.
- Implemented a payroll direct deposit program.
- Implemented a Section 457 deferred compensation plan.
- Initiated and implemented a Section 125 plan.

#### Risk Management

- Managed all aspects of the Village's risk management program and performed various risk management functions, including:
  - Administering the Village's liability, property, and workers' compensation insurance programs.
  - Administering claims.
  - Performing loss control activities.

#### **City Administrator, City of West Peoria, Illinois**

**October, 1994 - February, 2000**

Chief Administrative Officer responsible to the Mayor and eight-member City Council for the management of the municipal operations of a full-service, non-home rule municipality operating under the mayor-council form of government.

#### General Administration And Management

- Assisted the Mayor in his role as Local Liquor Control Commissioner administer and enforce state and local liquor codes within the corporate limits of the City.
- Developed and implemented plans, policies, procedures, and programs in many areas of municipal operations.
- Drafted ordinances and resolutions.
- Initiated, coordinated, and participated in strategic planning activities.
- Made policy and programmatic recommendations to the Mayor and City Council.
- Negotiated with both public sector and private sector entities on a variety of issues, including franchise agreements (including the City's first electric, natural gas, and telephone franchise agreements), intergovernmental agreements, and service contracts.

- Performed community, intergovernmental, and media relations activities.
- Prepared agendas and meeting packets for meetings of the City Council.
- Provided general administrative assistance and support to the Mayor and City Council.
- Provided research and analysis for the Mayor and City Council on policy and programmatic matters.
- Responded to citizen complaints and inquiries.
- Responsible for the administration and oversight of the City's cable television, electric, natural gas, and telephone franchise agreements.
- Served as Deputy City Clerk.
- Served as the first City Administrator less than a year after the incorporation of the City in 1993, demonstrating the benefits of professional local government management. Began on a part-time basis, which was converted to a full-time basis in July, 1995.

#### Budgeting And Financial Management

- Computerized all accounting and budgetary records.
- Initiated and implemented modifications to the budget document to improve readability and usability.
- Initiated the adoption of the Budget Officer System and served as Budget Officer.
- Responsible for the preparation and administration of the annual operating and capital budgets, as well as the preparation of the annual appropriation ordinance (prior to the adoption of the Budget Officer System) and the tax levy ordinance.

#### Community And Economic Development

- Assisted in the development of the City's first comprehensive land use plan.
- Assisted in the development of the City's first zoning code and served as Zoning Officer after its adoption, which included serving as Flood Zone Administrator.
- Established all zoning administration operating procedures.

#### Human Resource/Personnel Management

- Managed all aspects of the City's human resource/personnel system and performed all human resource/personnel functions, including:
  - Administering employee benefits.
  - Administering the City's drug and alcohol testing program.
  - Administering the City's pay plan.
  - Developing and implementing personnel policies and procedures.
  - Ensuring compliance with applicable laws and regulations.
  - In-processing and out-processing of employees.
  - Performing job analyses and preparing position descriptions.
  - Serving as ADA Coordinator.
- Developed the City's first official position descriptions.
- Implemented the City's first health insurance plan.
- Initiated and developed the City's first comprehensive personnel manual.

#### Public Works

- Developed a sidewalk replacement program to provide a mechanism for the replacement of the City's sidewalk infrastructure. Developed the ongoing funding mechanism for the program through cost-sharing with property owners and the utilization of special service areas.
- Developed an equipment and vehicle replacement program to provide a mechanism and funding for the planned replacement of the City's fleet of equipment and vehicles.
- Developed the City's first residential waste collection and recycling program. Responsible for the administration and oversight of the City's residential waste collection and recycling contract.
- Prepared a successfully-funded competitive grant application for a grant to provide recycling bins and recycling promotional materials for every residence in the City as part of the City's first residential waste collection and recycling program. Administered the grant upon its being awarded.
- Served on the Policy Committee of the Peoria/Pekin Urbanized Area Transportation Study (PPUATS).

Risk Management

- Managed all aspects of the City's risk management program and performed all risk management functions, including:
  - Administering the City's liability, property, and workers' compensation insurance programs.
  - Administering claims.
  - Performing loss control activities.

**Personnel Assistant (Part-Time), County of Peoria, Illinois****July, 1994 - July, 1995**

- Collected data and prepared materials in connection with collective bargaining activities.
- Prepared revisions to position descriptions.
- Prepared revisions to the County's personnel manual.
- Provided general administrative assistance and support to the Personnel Director and the staff of the Personnel Department.

**Administrative Assistant (Part-Time), Village of Peoria Heights, Illinois****May, 1994 - October, 1994**

- Administered the removal of architectural barriers grant initiated during internship.
- Provided general administrative assistance and support to the Village Administrator.

**Intern, Village of Peoria Heights, Illinois****January, 1994 - May, 1994**

- Developed a drug-free workplace policy.
- Developed a lockout/tagout program.
- Developed the Village's first employee performance review and evaluation system.
- Developed the Village's first merit-based pay system.
- Prepared a successfully-funded competitive grant application for a grant for the removal of architectural barriers to provide access by the disabled to the public restroom facilities and public drinking fountains at Village Hall. Administered the grant upon its being awarded.
- Provided general administrative assistance and support to the Village Administrator.

**EDUCATION****Master of Public Administration, Valdosta State University, Valdosta, Georgia****Bachelor of Science (Major: Political Science), Illinois State University, Normal, Illinois****Associate in Arts and Science (Major: Political Science), Illinois Central College, East Peoria, Illinois****Numerous conferences, seminars, webinars, and workshops****PROFESSIONAL MEMBERSHIPS****International City/County Management Association**

ICMA Credentialed Manager

Member, 2008 Conference Evaluation Committee

Member, 2011 Conference Planning Committee

Member, Review Committee For 2014 ICMA Annual Conference Scholarship Applications

Member, Task Force To Update The ICMA Model Employment Agreement

Service Awards - 10 Years, 20 Years

**Illinois City/County Management Association**

Member, Committee On Professional Conduct

Member, Membership Services Committee

Participant, Manager/Administrator Outreach Program

**Downstate City/County Management Association****Government Finance Officers Association Of The United States And Canada****International Economic Development Council****International Council Of Shopping Centers****National Public Employer Labor Relations Association****Illinois Public Employer Labor Relations Association**

## MOLLY TALKINGTON

737 Kimberly Drive, DeKalb, IL 60115

• 630-405-3899 • mollytalkington@hotmail.com •

---

### LEADERSHIP/ FINANCIAL MANAGEMENT / ANALYSIS

An accomplished management and finance professional with 15 years of progressive management and fiscal management/analysis experience with in-depth knowledge of government accounting and finance. Expertise in City administration, operations leadership, budget development/management, capital improvements program development/implementation, financial reporting and federal, state and local compliance. Exemplary analytical, organizational and communication skills, working effectively with staff and management at all levels.

- Organizational Leadership
- Budget Development/Management
- Government Financial Reporting
- Financial Analysis
- Procedure/Process Improvements
- Cost Reductions/Revenue Growth
- Employee Management/Development
- Business Planning

**Master of Public Administration - Concentration: Fiscal Administration, Northern Illinois University, DeKalb, IL**  
**Bachelor of Science – History (Political Science minor), University of Wisconsin-Whitewater, Whitewater, WI**

---

#### **VILLAGE OF EAST DUNDEE, East Dundee, IL via GovTemps**

**2019 to 2019**

The Village of East Dundee (pop. 2,860) is a quaint and successful community committed to its residents and businesses. The historical downtown runs along the Fox River and features the well-travelled Fox River Bike Trail. The Fiscal Year 2019 General Fund budget is \$5.90 million, and all funds total \$20.88 million with a Baa1 Moody's bond rating.

#### **Interim Finance Director/Treasurer:**

Reports to the Village Administrator. Oversees all the financial processes, policies and systems for the Village including budget development, financial forecasting, accounting and financial reporting, auditing, treasury management, investments, payroll, purchasing, utility billing, debt administration, revenue collections, and vendor disbursements. Key member of the Executive Team and has frequent contact with elected officials, committee members, and community at large. Manages and trains a staff of two. During the interim period, completion of the following:

- Acclimation to the Village's operations and structure
- Preparation and presentation of the Fiscal Year 2020 Budget
- Development of a Capital Improvement Plan in conjunction with the Fiscal Year 2020 Budget
- Assessment of the staffing needs of the Finance Department and recruitment and hiring of the Finance Clerk, a key customer service position within the Village
- Consolidation of the Village's funds together with the auditors
- Revision and update the Village's long-term cash flow projections and fund balances

#### **CITY OF DEKALB, DeKalb, IL**

**2017 to 2019**

The City of DeKalb (pop. 44,030) is a historically farmland city that has become the cultural center for the county. DeKalb is home to Northern Illinois University; the second largest university in the State of Illinois system. The Fiscal Year 2018 General Fund budget is \$37.7 million, and all funds total \$93.7 million with an A1 Moody's bond rating.

#### **Interim City Manager:**

Reports to the Mayor and City Council as of June 2018 and returned to Finance Director in November 2018. Oversees and supports the implementation of the policies established by the City Council. Responsible for the administration, management, and oversight of daily municipal operations. Oversees a significant number of administrative responsibilities to support the functions of the City Council. Direct management of the City's seven Department Heads and the City Manager's Office. Ensures the service level outcomes align to the City of DeKalb 2025 Strategic Plan initiatives and Council goals while remaining within the annual funding constraints.

- Promoted to Interim City Manager role within ten months of employment with the City of DeKalb.
- Leads and provides clear direction for the daily municipal operations for the Police, Fire, Public Works, Finance, Community Development, City Manager's Office, Human Resources, and Information Technology even with a vacancy in a key position, the Assistant City Manager.
- Provides research, data, and professional recommendations to inform City Council policy decisions.
- Directs special projects that involve multiple departments, other government entities, the community, and/or Northern Illinois University.
- Enhanced leadership and management of the yearlong Fiscal Year 2019 budget process to bring the budget within the fund balance policy through over \$1.6 million in budget balancing measures (mainly service reductions).
- Coordinate Town and Gown initiatives and lead Northern Illinois University Community programs.
- Supervise the City's communication and public relations initiatives.
- Currently directing the transition to an Administrative Hearing process and a Tax Increment Financing (TIF) project for one TIF close out, project selection and dedication, and potential shrinkage of a current TIF with the creation of a new TIF.

#### **Finance Director:**

Reports to the Assistant City Manager. Oversees all the financial processes, policies and systems for the City including budget development, financial forecasting, accounting and financial reporting, auditing, treasury management, investments, payroll, purchasing, utility billing, debt administration, property and casualty insurance, licensing, revenue collections, and vendor disbursements. Key member of the Executive Team and has frequent contact with elected officials, committee members, and community at large. Manages and trains a staff of eight.

- Manage an annual operating budget of \$93.7 million (Fiscal Year 2018).
- Serve as Acting City Manager.
- Leading a yearlong Fiscal Year 2019 budget process to ensure the adopted budget aligns to the City Council's goals with emphasis on service levels and the impact on the community.
- Managed Fiscal Year 2018 budget adoption with expenditure reductions of \$1.3 million (\$936,000 General Fund) including position eliminations.
- Restructured through a position elimination and increased cross-training in the Finance Department.
- Leads the City's replacement of the financial and human resources software and associated process and procedure evaluation and revision (Selected BS&A).
- Finalizing the City's first Five-Year Financial Plan and Asset Management Plan.
- City lead on securing a property tax abatement and levy rebate as a payback to the taxpayers' loan to the DeKalb Public Library since a \$4.5 million grant payment from the State of Illinois was delayed three years.
- Present Council Reports and financial information before the DeKalb City Council, Finance Advisory Committee, internal staff meetings, and outside agencies.
- Police Pension Board City appointed member.

#### **CITY OF CHAMPAIGN, Champaign, IL**

**2010 to 2017**

The City of Champaign (pop. 81,055) is a vibrant Central Illinois community. The Fiscal Year 2017 General Fund budget is \$85.2 million, and all funds total \$140.5 million with a AAA Moody's bond rating.

#### **Financial Services Manager/Budget Officer:**

Reports to the Finance Director. Oversees all aspects of city-wide development, implementation, and monitoring of the Annual Operating Budget and Capital Improvements Program. Leader and core member of the financial and human resources software replacement and process evaluation and improvement team. Manages and trains a staff of four.

- Manage an annual operating budget of \$85.2 million (Fiscal Year 2017).
- Annually improve the City's Distinguished Budget Award rating through the Government Finance Officers' Association.
- Manage multiple fiscal years of budget balancing measures (\$18.5 million in total; mainly expenditure reductions including staffing citywide).

- Enhance the City's revenue base to restore City services.
- Manage the City's purchasing program and monitors compliance to policies and procedures
- Leads the City's replacement of the financial and human resources software and associated process and procedure evaluation and revision (Selected Tyler Munis).
- Serve as Acting Finance Director.
- Present Council Reports and financial information before the Champaign City Council, internal staff meetings, and outside agencies.
- Received three service awards; Two Teamwork – Budget Team and Comprehensive Organizational Research Evaluation Leadership Team and one individual for Responsibility.

**VILLAGE OF GLENVIEW, Glenview, IL**

**2008 to 2009**

The Village of Glenview (pop. 44,000) is an affluent community on Chicago's North Shore. Fiscal Year 2009 General Fund budget was \$53.3 million, and all funds totaled \$213.4 million with a AAA bond rating.

**Budget Manager / Senior Budget Analyst:**

Reported to the Chief Financial Officer. Responsible for overseeing all financial aspects of village-wide development; implementation and monitoring of the Annual Operating Budget and Capital Improvements Program.

- Managed an annual operating budget of \$53.3 million (Fiscal Year 2009).
- Oversaw and performed accounting and internal audit work relating to Village accounts and development of the Comprehensive Annual Financial Report.
- Presented Board Reports before the Village Board of Trustees.
- Overhauled entire Village budget process and document to conform to best practices.
- Implemented a business plan structure to ensure compliance to budget constraints and measure village-wide performance on an annual basis.
- Revised the chart of accounts structure to enhance functionality and facilitate better reporting.
- Enhanced the Village's revenue base to reduce reliance on property tax.
- Managed the Finance Department during the realignment of the Chief Financial Officer and Accounting positions to ensure optimal service levels were maintained during the transition.
- Ensured rate structures of Enterprise Funds were sufficient to meet the needs of funds operations.

**CITY OF NAPERVILLE, Naperville, IL**

**2002 to 2008**

The City of Naperville straddles DuPage and Will Counties in the Chicago metropolitan area. It is the fifth largest city in Illinois (pop. 147,779). Fiscal Year 2008 General Fund budget was \$106.5 million, and all funds totaled \$429.3 million with a AAA Moody's bond rating.

**Budget & CIP Analyst / Financial Reporting Analyst**

**2004 to 2008**

Reported to the Financial Reporting Team Supervisors. Oversaw all aspects of citywide financial development; implementation and monitoring of the Annual Operating Budget and Capital Improvements Program.

- Participated in all aspects of the Annual Operating Budget process, Comprehensive Annual Financial Report, and Popular Annual Financial Report.
- Coordinated and prepared Federal, State and Local grant process and reports.
- Performed accounting and internal audit work related to City accounts.
- Oversaw the upgrade of the Capital Improvements Program database, resulting in easier access for customers and improved financial reporting capabilities.
- Overhauled business plan, rate schedule and overall structure of the Commuter Parking Fund improving service delivery levels.
- Measured annual citywide performance through the Annual Operating Budget process and ongoing performance indicators.
- Conducted a comprehensive redesign of the city's grant procedures, resulting in better internal controls and more accurate reporting.
- Created a Special Events procedure manual to improve coordination between departments and service to the community.

- Ensured the City was meeting Public Safety needs through development of custom-designed specifications of three new Pumper Trucks for the Naperville Fire Department.
- Began as the Finance Intern from 2002 to 2004.

### PROFESSIONAL ENGAGEMENTS

- *I Want a New Job: Career Options for a Finance Officer*, Moderator for the Government Finance Officers Association (GFOA) Annual Conference, 2018
- *How to Build a Finance Office*, Moderator for the GFOA Annual Conference, 2016
- *Forecasting and Monitoring Municipal Revenues and Simplifying Labor and Benefits Expenditures*, Presenter for the Illinois Government Finance Officers Association (IGFOA) Academy II, 2018
- *Emerging Finance: Challenge of Funding Change in Law Enforcement*, Presenter for IGFOA Annual Conference, 2018
- *Capital Improvement Planning and Financing: The How, When, Who, and Why?*, Presenter for the IGFOA Annual Conference, 2016
- *Basic Budgeting*, Presenter for the Illinois Municipal Clerks' Association, 2016, 2017 & 2018
- *Financial Forecasting*, Presenter for the IGFOA, 2015
- *Revenue Roundtable*, Presenter and Conference Organizer for the IGFOA Downstate Chapter Annual Conference, 2014
- Conference Organizer and Moderator for the IGFOA Downstate Chapter Annual Conference, 2017

### TECHNICAL SKILLS

- Microsoft Office
- Munis Financial Software
- Sungard/HTE Financial Software
- BS&A Financial Software
- Questica Budget Financial Software
- Harris (GEMS&MSI) Financial Software
- Locis Financial Software
- Adobe Professional

### AWARD REVIEWER

- Popular Annual Financial Reporting Award for GFOA (one of five reviewers in the State of Illinois), 2007 to Present
- Distinguished Budget Award for GFOA, 2005 to Present

### MEMBERSHIPS/AFFILIATIONS

- Member, Government Finance Officers Association, 2008 to Present
- Member, Illinois Government Finance Officers Association, 2004 to Present
  - President, Downstate Chapter, 2018 to Present
  - Downstate Representative, Executive Board, 2018 to Present
  - Vice President & Central Region Coordinator, Downstate Chapter, 2015 to 2017
  - Member-At-Large & Central Region Coordinator, Downstate Chapter, 2014 to 2015
- Member, National Institute of Government Professionals, 2011 to 2017
- Member, Illinois Association of Public Procurement Officials, 2011 to 2017
- Member, Illinois City / County Management Association, 2002 to 2016
- Member, Illinois Assistant Municipal Managers Association, 2002 to 2016

### COMMUNITY ENGAGEMENTS

- First United Methodist Child Care Center Committee Member, Champaign, IL, 2015 to 2017
- Steeple Run Condominium Association, President/Building & Maintenance Director, Naperville, IL, 2004 to 2008; 2009 to 2011



# KELLI TRUVER, PHD, CAVS

---

2612 Crozier Ave. Kingman, AZ 86401 | (507)441-1915 | KelliTruver@gmail.com

*An accomplished professional with experience in managing nonprofits and small communities.*

## SKILLS & ABILITIES

---

Mid-level and volunteer coaching  
Staff-patient/client interaction training  
Patient flow process improvement  
Microsoft Office products

## EXPERIENCE

---

- 2019-2019      **City Manager, *Sleepy Eye, MN***  
Sleepy Eye, MN is a small town located in Southwestern Minnesota with a population of roughly 3,500. As the City Manager, I worked closely with department heads and community leaders to continue to develop and grow the downtown district of Sleepy Eye. I also led the development of large scale street projects and property negotiations. In this role, I had HR responsibilities and redesigned the City's personnel policies and handbook. I also oversaw the operation of the municipally owned utility services, airport, hospital, event center, and library.
- 2014-2019      **Manager, Volunteer Services, *Kingman Regional Medical Center***  
Kingman Regional Medical Center (KRMC) is a nonprofit, community owned, regional medical center that includes an acute care hospital, outpatient services, primary care, specialty clinics, and urgent care services serving all of Mohave County, Arizona. As the leader of volunteer services, I work closely with patient experience leaders to provide support for exceptional patient experience through the continuum of care. Responsibilities include coaching for behavior improvements, developing key service positions to better serve patient needs, and continued growth among volunteer service hours.
- 2018-2019      **Associate Faculty, *Mohave Community College***  
Mohave Community College (MCC) is a community college serving more than 13,000 students primarily in Mohave County, Arizona, but also in northwestern Arizona and the neighboring communities in California, Nevada, and Utah. MCC has multiple campus locations in Mohave County and an extensive distance education program. Responsibilities include developing and implementing weekly lesson plans for associate level education, facilitating group discussions, and fostering an environment conducive to learning.
- 2017              **Presenter, Association of Hospital Volunteer Resource Professionals (AHVRP) Annual Conference**

The AHVRP is a professional membership group of the American Hospital Association (AHA). I presented during 3 concurrent sessions at the 2017 annual conference. Topics included the innovative programs I initiated while heading the volunteer department at Kingman Regional Medical Center.

2014-2015

**Adjunct Faculty, *Jones International University***

Jones International University (JIU) was a fully online university headquartered in Colorado. JIU offered associates, bachelors, masters, and doctoral degree programs. Responsibilities included implementing weekly lesson plans for bachelor level education, administering testing, tracking and analyzing student performance, fostering an online classroom environment favorable to learning, established and communicated clear objectives for learning activities, and maintained accurate and complete records of students' progress.

2013-2015

**President, Advisory Board, *Big Brothers, Big Sisters of Mohave County***

Big Brothers Big Sisters of Mohave County (BBBS) is associated with Big Brothers Big Sisters of America and operates in Mohave County, Arizona. I served as president on the advisory board and as a volunteer "big sister" with BBBS. Responsibilities included leading board meetings, developing funding and recruitment strategies, conducting promotional media interviews, and developing positive relationships with donors.

2011-2014

**Business Operations Manager, *Capable Technology***

Capable Technology is a computer and network consulting business that provided computer repair services, commercial wifi network installations, and full service IT solutions for businesses. In the role of Business Operations Manager, I worked closely with the CEO to develop an effective business model that allowed the company to expand its client base nationwide. Responsibilities included managing field technicians and office staff, onboarding new staff, overseeing vendor contracts and purchasing, and developing and implementing sales, marketing, and customer care strategies. In this role, I was able to develop and implement a customer service training program for staff.

2009-2011

**Family Relationship Educator & Youth Development Coordinator, *Arizona Youth Partnership***

Arizona Youth Partnership (AZYP) is a nonprofit youth organization serving multiple counties in Arizona including Pima, Mohave, Gila, and Navajo. The majority of AZYP's funding comes from government grants; however, individual donations are a small funding source. Responsibilities included planning and leading coalition meetings for adults and youth, promoting and recruiting families for the Strengthening Families Program (SFP), and teaching the SFP to entire families. Key accomplishments include planning, promoting, and leading the largest Walk Away From Drugs event in Lake Havasu City. In this role, I lead several community events including town hall meetings. I worked closely with the juvenile justice system.

## EDUCATION

---

PhD, Public Administration, *Northcentral University*

MBA, Public Administration & Global Management, *Ashford University*

BS, Accounting, *Kaplan University*

AA, Mathematics & Spanish, *Mohave Community College*

Certified Administrator of Volunteer Services (CAVS), *Association of Hospital Volunteer Resource Professionals (AHVRP)*

Property, Casualty, Life, & Health/Accident Insurance License, *Arizona Department of Insurance*

## **BOGDAN VITAS**

**Mobile: 224-202-4107 E-Mail: bobvitas@gmail.com**

### **PROFESSIONAL PROFILE**

A senior local government executive with diverse experience in overseeing complex government organizations coupled with extensive private sector management consulting experience for US Agency for International Development and US Department of Homeland Security FEMA programs. Innovative results driven leader that strongly encourages team work and values individual performance with a collaborative management style to achieve organizational excellence. High-energy entrepreneurial professional skilled in business planning methodologies and fully capable of linking plans, budgets, programs and projects to achieve measurable results.

### **MULTI-DISCIPLINARY AREAS OF EXPERTISE AND SPECIALIZED KNOWLEDGE**

- Strategic Management Planning
- Economic and Community Development
- Human Resources and Labor Relations Management
- Disaster Management & Technical Assistance, FEMA
- Financial Management
- Procurement & Debt Management
- Community Outreach & Engagement
- Intergovernmental Relations

### **PROFESSIONAL EXPERIENCE**

#### **Associate, Independent Consultant**

**Beni Suef Governorate, Egypt, population 3.214 million**

**AmidEast, Washington, DC**

**March 2019 – present**

- Independently prepared and conducted a successful four-day training program for 50 government officials from the Egyptian Ministry of Local Development and Central Development Unit, Governorate of Beni Suef Local Development Unit and newly created Economic Partnership Council; the first such economic development organization in Egypt. Training workshops related to US based economic development, community outreach and engagement best practice models as part of the US Agency for International Development funded Workforce Improvement and Skill Enhancement program in place throughout 11 of 27 Egyptian Governorates.
- Phase two of the engagement includes preparing and conducting a week-long study tour to Catawba County and the cities of Charlotte and Hickory, North Carolina for 30 government officials and private sector participants to gain first-hand knowledge on best practice models for sustainable economic development and community engagement allowing Beni Suef to serve as a future model for all 27 Egyptian Governorates.

#### **Interim Town Manager, Independent Consultant**

**Town of Pembroke Park, Florida, population 6,102**

**July 2018 – February 2018**

- Researched, prepared and implemented a fully transparent, accountable, and balanced annual budget for FY 2019. The budget development process revealed a ten-year history of deficit spending and related depletion of the general fund reserve by nearly 50% due in large part to gross mismanagement lack of proper oversight.
- As part of the FY 2019 budget implemented a new job classification and compensation plan, reducing gross salaries by over \$900K and funding 19 vacant positions resulting in net reduction of salary spending by \$582K.
- Initiated and successfully completed a forensic audit of contracted police, fire and rescue services with the Broward County Sheriff's Office identifying combined fiscal losses in excess of \$6 M for Pembroke Park and the City of West Park, Florida. Audit identified contract driven allowances and overspending beyond the Miami-Dade, Broward, and West Palm Beach CPI-U of more than \$24 M over the prior 15 years.
- In conjunction with the Auditor was instrumental in completion of FY 2017 annual audit in light of numerous delays, in major part related to a lack of Town Commission approved meeting minutes as far back as May 2017
- Conducted a thorough review and prepared recommendations for the Town's first-time public procurement manual and new employee handbook replacing their 1987 personnel policy manual.
- All of the above projects were recommended in a final report issued by the Office of the Inspector General of Broward County following the removal of the previous Town Manager, Assistant Town Manager, Finance and Budget Director, and other key staff in the Manager's Office and Finance Department.

## **BOGDAN VITAS**

**Mobile: 224-202-4107 E-Mail: bobvitas@gmail.com**

### **Town Manager**

**October 2015 – October 2017**

**Town of South Palm Beach, Florida population 3,000, Chief Executive Officer with oversight of a \$3.5 M budget, 4 departments, 15 full time employees, and 12 contracted service departments**

- In concert with Town Council and Town Staff developed and implemented the Town's first multiyear Action Plan for FY 16, 17 and 18 that prioritized strategic projects and programs related to significant capital improvements, investments and the delivery of municipal services.
- Overhauled total budget process instituting a new Chart of Accounts to ensure consistency of reporting across all funds and departments, inclusion of prior audited year-end financial data, worksheets for Department Head requests resulting in greater transparency and accountability. FY 17 ended with a \$591K unexpended balance
- Relocated all financial management and accounting services in house in FY 16, acquiring software from USTI and integrating all historical financial data from prior years, along with staff training on all finance modules
- Spearheaded effort to secure letters of intent from 15 of 16 ocean front properties to participate in granting public easement agreements to Palm Beach County for the Southern Palm Beaches Island Comprehensive Shoreline Stabilization Project; a \$10 M multijurisdictional project in its tenth year
- Initiated and directed projects to secure new vendors to provide multiple services related to information technology, copier, and document imaging needs. Project reduced costs, insured improved IT services, enhanced security of all town records in cloud storage, and created sustainable records management
- Successfully negotiated two multi-year labor agreements with the Palm Beach County Police Benevolent Association resulting in the removal of contract language that financially harmed the Town related to mandatory grievance arbitration for disciplinary matters saving future legal costs estimated in excess of \$100K
- Successfully completed update of DHS Federal Emergency Management Agency Flood Insurance Rate Maps resolving incorrect boundary lines, preserving flood elevations and continuation of flood insurance program
- Managed successful completion of emergency sanitary sewer lateral replacement projects related to failed original infrastructure well beyond useful life and deferred maintenance, including replacement of failing sanitary sewer pumps at the lift station to reduce I & I and operating costs
- Prepared, released and presented a Request for Proposal for Architectural and Engineering Services to prepare a structural evaluation, spatial needs analysis, development of Town Hall conceptual plans

### **City Manager**

**July 2012 – July 2014**

**City of Key West, Florida population 24,649, Chief Executive Officer with oversight of a \$155 M budget, 12 operating departments, 6 divisions, and 475 full time employees**

- Created a one of a kind Annual Business Plan for FY 2014 that integrated the Strategic Plan, Capital Improvement Plan, and Annual Budget to report and monitor monthly progress on the achievement of all programs/projects, to provide for full transparency and accountability to achieve strategic goals and objectives
- Efficaciously managed a capital improvements projects portfolio in excess of \$145 M representing over 129 ongoing projects across all seventeen operating departments
- Completed a Compensation Study, the first in 20 years, to meet market rates, address external competitiveness to reduce turnover, and internal parity amongst the workforce. (49% of all employees were reported as below the minimum starting wages rates). Reduced turnover 50% from 14% in FY 12 to less than 7% in FY 14
- Launched the first comprehensive Performance Evaluation Program for all union and non-union employees to promote personal performance in attaining city goals and objectives across departments.
- Successfully negotiated new multi-year labor contracts in 2012 with the Teamsters, PBA and IAFF unions after five years of stalled negotiations improving labor management relations and morale
- Spearheaded approval process for reuse of former US Navy property attained under BRAC after 15 years allowing for development of a new 26-acre world class park at the historic Truman Waterfront valued at \$48M including utilities, community center, horse stables, restaurant, water park, artificial turf fields, jogging trails
- Lead negotiator with the US Navy to obtain a long term intergovernmental public benefit lease for the Navy's outer mole pier at Truman Harbor to maintain cruise ship berthing and secure ongoing funds for capital improvements and future maintenance at the future Truman Waterfront Park
- Orchestrated final approval after 15 years for adaptive reuse and construction of a new 35,000 square foot City Hall project valued at \$17.2M, Gold LEED certified, and to adaptively reuse and preserve a historic building

## **BOGDAN VITAS**

**Mobile: 224-202-4107 E-Mail: bobvitas@gmail.com**

- After 17 years succeeded in obtaining approval to construct a new state of the art Fire Station in the old town historic district valued at \$6 M including public parking lot and restroom facilities
- Obtained approval to issue a design build contract for a new Transportation Center at cost of \$10 M to house and service the City's public transit system buses serving Key West and the Lower Keys

### **Associate, Independent Consultant**

**January 2012 – March 2012**

#### **Management Systems International, Washington, D.C**

- Co-author, chief technical advisor and field recruiter for a USAID Governance, Accountability, Participation and Performance program proposal to provide the Republic of Uganda government with technical assistance to strengthen its service delivery systems and enhance civil society by giving Ugandans a voice in government

### **Village Administrator**

**December 2007 – December 2011**

#### **Village of Lake Zurich, Illinois population 19,964, Chief Administrative Officer with oversight of a \$45M budget, 7 operating departments and 172 full time employees**

- Initiated and developed a tailored comprehensive strategic management planning system to provide for more transparent, accountable and efficient government; including community outreach measures, internal self-assessments, and performance measurement tools resulting in the establishment of clear and attainable strategic goals and objectives linked to realistic financial resources, budgetary plans and delivery of services
- Successfully initiated and orchestrated a public referendum to authorize a local non home rule sales tax of .5% projected to raise \$2.0M for public infrastructure improvements and general property tax relief, and a 2.5% Municipal Utility Tax raising \$750K in new revenue to assist with general fund expenditures
- Prepared a new Employee Handbook in accordance with all current applicable Federal and State employment laws, replacing an outdated 1988 Personnel Policy Manual
- Evaluated Village's partially self-funded health insurance program and migrated to a fully funded plan, resulting in a recurring \$1M reduction in annual premium costs to the Village
- Developed and implemented a Job Classification and Compensation Plan and Management Audit to establish internal and external equity for non-union employees, and merit-based pay for performance evaluation system
- During the Great Recession restructured and reorganized resulting in a reduction of 26 full time positions and a permanent cost savings in excess of \$2.5M in salary and fringe benefits while not impacting service levels
- Re-examined existing labor agreements based on the downturn of the economy and renegotiated the terms of the final contract years resulting in a \$700K cost saving to the taxpayers. All employees accepted a salary freeze and ten percent increase in individual health insurance premium costs
- Negotiated memorandum of agreement with Canadian National obtaining \$2M for mitigation costs for impacts of rail operations pursuant to final environmental impact statement from US Surface Transportation Board
- Achieved prestigious Government Finance Officers Association Distinguished Budget Presentation Award
- In concert with Finance Director and consultants devised a financial plan to restructure and refund \$14M of TIF debt temporarily resolving a long-standing internal financial crisis affecting all municipal funds
- Maintained Moody A-1 Bond Rating for all prior debt obligations and obtained a Standard and Poor AA+ bond rating for restructuring and refunding of \$14M in TIF obligation debt resulting in a \$1M cost savings
- Managed to fully fund public safety pension fund annual actuarial requirements for the past four fiscal years, reversing a 17 history of underfunding, increasing general fund tax levy contributions from \$400K to \$2.5M
- Renegotiated intergovernmental agreements between Lake Zurich and Rural Fire Protection District resulting in \$600K in increased revenue to the Village from four adjoining municipalities
- Completed an intergovernmental agreement with the North Barrington and Lake County for extension of sanitary sewer services generating \$840K in connection fees and significant water and sewer revenues
- Attracted two new commercial businesses in the TIF district, orchestrated the development of a new park, oversaw the remediation of two Brownfield sites, and demolition of buildings to create pad ready sites
- Successfully resolved long standing 18-year dispute with Village of Kildeer resulting in a new intergovernmental agreement allowing for development of commercial properties on Illinois Routes 12 and 22

## **BOGDAN VITAS**

**Mobile: 224-202-4107 E-Mail: bobvitas@gmail.com**

- Coordinated and negotiated the successful conclusion of a \$9M lawsuit against the Village, TIF district developer and lending institution, resulting in the return of Village property, payment of \$750K non-disputed funds, termination of the development agreement, and limiting loss to under \$250K to assist in satisfying liens

### **Associate, Independent Consult**

**September 2007 – December 2007**

#### **The Mitchell Group, Inc., Washington, D.C.**

- Co-author and chief technical advisor to develop monitoring and evaluation criteria/instruments to review the performance of all completed USAID funded contracts in the Republic of Serbia including: the Serbia Local Government Reform Program; Serbia Enterprise Development Project; and all five Community Revitalization through Democratic Action programs.

### **Vice President, Community Municipal Economic Development Programs October 2006 – September 2007 America's Development Foundation, a 501c (3) corporation, Belgrade, Serbia**

- Developed several models to finance Micro, Small and Medium Enterprises for Serbian municipalities to promote local economic development, generate employment and increase local tax revenues. The models ranged from traditional municipal revolving loan fund programs to those including credit enhancements by commercial banks and guarantees through the Republic of Serbia National Guaranty Fund.
- Developed business plan and launched new business programs serving Serbian municipalities and cities, also serving small and medium business enterprises.

### **Deputy Operations Manager – City of New Orleans**

**January 2005 – September 2006**

#### **Regional Program Manager – South Central and South Western Louisiana**

#### **U. S. Department of Homeland Security - FEMA Long Term Community Recovery Program**

#### **AECOM International Development, Washington, D.C.**

- Responsible for the development of strategic plans for long term community recovery of the City of New Orleans and St. Bernard Parish. Managed a team of 45 consultants in the areas of housing construction and rehabilitation, land use management, historic preservation, economic development, and public infrastructure
- Responsible for the rapid development of strategic plans for long term community recovery of FEMA Region 1 consisting of 6 Parish Governments. Managed a multi-disciplinary team of 55 professionals

### **Country Director**

**November 2001 – December 2005**

#### **Project Manager – City of Belgrade Metropolitan Project**

#### **Chief Local Government Advisor - Financial Management and Citizen Participation**

#### **USAID Serbia Local Government Reform Program, Republic of Serbia (former Yugoslavia)**

#### **AECOM International Development, Washington, D.C.**

- Served as Acting Chief of Party. Progressively responsible senior level positions over a five-year funded \$29.8M program for 87 local governments (4 cities and 83 counties) representing 92% of the country's 9.39 million population. My areas of assistance to citizens, municipalities, Federal Ministries, and NGOs included Financial Management, Citizen Participation, Public Procurement, Information Technology, and Policy Reform.
- Negotiated, secured and managed the \$3M Metropolitan Belgrade Project, a multidisciplinary project comprised of four technical teams for the City of Belgrade (population 1,576,124 comprising its 17 Counties)
- Designed, managed and implemented a three-phase public budget hearing process model in 87 municipalities resulting in 184 public hearings, 10,600 citizen participants, and securing \$70M local government funding for citizen initiated capital projects in the first year of implementation
- Annually conducted 5 regional workshops including Public Budget Hearing Process, Establishing e-Citizen Assistance Centers, Establishing e-One Stop Permitting Centers, Communications for Local Government Officials and Strengthening Local Communities
- Planned and managed the establishment of 9 municipal e-Citizen Assistance Centers to streamline both notary and registry services (the issuance of certificates, licenses, and social welfare benefits), the establishment of 8 municipal e-One Stop Permitting Centers, and establishment of Business Improvement Districts in 4 cities
- Managed the design, development and implementation of 8 financial management training modules including: Strategic Management Planning & Development, Budget Classification & Chart of Accounts, Composition and

## **BOGDAN VITAS**

**Mobile: 224-202-4107 E-Mail: bobvitas@gmail.com**

Preparation of the Budget, Budget Execution, Accounting and Internal Auditing, Capital Budgeting, Consolidated Treasury & Enterprise Accounting, and Debt Management Planning

- Conducted 18 financial management regional training workshops for 805 municipal participants and 139 field-training sessions for 4,424 municipal employees totaling 5,229 municipal officials over two-year period. All training was completed on schedule, within budget and successfully implemented by local governments.
- Appointed as Senior Member of Republic of Serbia Ministry of Finance and Economy Budget Task Force and Treasury Task Force in 2003 to assist in the development of rules, regulations and guidelines governing the application and implementation of the new Budget System Law by all local governments

### **City Administrator**

**November 2000 – November 2001**

**City of Lewiston, Maine, population 35,690, Chief Executive Officer with oversight of a \$67.7M budget, 15 operating departments and 550 employees**

- Attracted and negotiated Wal-Mart's state of the art Distribution Center project serving the Northeastern US and Canada, resulting in 400 new full-time jobs, \$9M annual payroll, \$40.5M in private investment, \$500 K in new property tax, and construction of a 485,000 sq. ft. facility. Structured incentive package of \$17M for the necessary water and sewer upgrades, sale of City owned land, tax increment-financing package, State training grants and reconstruction of the USH 95 Maine Turnpike interchange
- Negotiated the sale for 3 of 10 City owned former Bate's textile mill buildings (\$5.5M) to private sector, increasing the annual local tax base by \$157,410 and leveraging \$15M in new private investment
- Resolved several matters of litigation related to City acquisition of both the fee simple and leasehold interests of private property for library expansion resulting in \$250,000 acquisition cost savings
- Converted traditional line item financial management system to a performance-based budgeting system and restructured and implemented a new Capital Improvement Plan and Budgeting system

### **Deputy Director, Division of Urban Management, Finance, and Governance May 2000 – November 2000**

**Senior Financial Advisor, short term, USAID contract Republic of Zambia**

**Planning & Development Collaborative International, Washington, D.C.**

- Principal areas of responsibility included division management, business development, project management, and proposal writing. Provided technical expertise in the areas of legal sustainability, policy frameworks, democratic processes, financial resources, municipal services, and institutional support systems for project teams worldwide.
- Designed and released a competitive request for proposal for the City of Lusaka, Zambia, to procure professional consultant services for the valuation of real property (70,000 parcels). Provided technical assistance for the evaluation of bids and preparation of final contract documents for USAID funded project.

### **Government Finance Advisor, USAID contract, Federation of Bosnia-Herzegovina February – April 1998**

**International City and County Management Association, Washington, D.C.**

- Developed documentation and delivered budgetary training workshops based on the IMF Classification System, including citizen participation processes for Bosnia-Herzegovina city and cantonal finance and elected officials. USAID funded project for Capital City and Canton of Sarajevo and the principal regional cities of Zenica, Tuzla, Bihac, Livno, and Tomislavgrad located in the Federation of Bosnia-Herzegovina

### **Local Government Advisor, USAID contract, Federation of Bosnia-Herzegovina December – March 1996**

**International City and County Management Association, Washington, D.C.**

- Conducted an evaluation on the organizational restructuring and governmental financial reporting systems for the City of Sarajevo. Authored final adopted report with detailed recommendations for the complete reorganization of the City of Sarajevo in accordance with the newly adopted cantonal government constitution.

### **Town Administrator**

**July 1991 – May 2000**

**Town of Menasha, Wisconsin, population 16,546, Chief Administrative Officer with oversight of a \$22M budget, 11 operating departments and 198 employees**



## **BOGDAN VITAS**

**Mobile: 224-202-4107 E-Mail: bobvitas@gmail.com**

- Negotiated attraction of a new \$500M Kimberly Clark industrial manufacturing facility on 140 acres generating 352 jobs, increased tax revenues and stabilized local tax rate
- Structured and spearheaded attraction of a new \$75M commercial retail/office and residential development project located on 215 acres creating a new Town Center with future plans for a 10K seat convention center
- Attracted new \$28M Kimberly Clark R&D/Conference Center facility, including the award of a \$250K State of Wisconsin Transportation Economic Assistance Grant for highway improvements
- Obtained a \$750K WDOD economic development public facilities grant commitment to install new water and sewer lines, and improve local roads to support new industrial complex growth
- Developed the concept and legal mechanisms for the design build construction of the Municipal Complex Building Project (34,000 square feet) including all furnishings, equipment and site development for \$3.1M or \$59 per square foot without any tax levy increase and consolidated all municipal operations
- Orchestrated settlement of two 50-year-old disputes between the Town and Cities of Appleton and Menasha resulting in intergovernmental agreements establishing jurisdictional boundary lines, consolidation of Town's Para transit system and re-establish fixed route bus service resulting in overall cost reductions, service improvements and enhanced federal and state aids
- Spearheaded overall consolidation of Sanitary District after 30 years of operating as independent Municipal Corporation and development of organizational and transitional operation management plans. Established four intergovernmental agreements and consent resolutions from all served adjoining municipalities
- Developed first comprehensive program budget in accordance with GAAP and State of Wisconsin Chart of Accounts to improve public accountability and transparency in the financial reporting systems resulting in attaining first State of Wisconsin GRATE Award for Town's Financial Statements
- Successfully negotiated multiple multi-year labor contracts with AFSCME, IAFF, and FOP unions, and defended against employee claims of wage discrimination, sexual harassment, and workman's compensation

### **OTHER LOCAL GOVERNMENT EXPERIENCE**

Administrator of Finance and Personnel, McHenry, Illinois

Director of Economic Development Services, East Moline, Illinois

Assistant to the City Manager, Crystal Lake, Illinois

Administrative Assistant, Willowbrook, Illinois

### **NATIONAL INCIDENT MANAGEMENT SYSTEM CERTIFICATIONS**

United States Department of Homeland Security FEMA Emergency Management Institute

ICS 100 Introduction to the Incident Command System

ICS 200 Single Resources and Initial Action Incidents

ICS 300 Intermediate ICS for Expanding Incidents

ICS 631 Public Assistance Operations

ICS 632 Introduction to Debris Operations

ICS 00907 - Active Shooter: What Can You Do

Texas A&M University System - US Department of Homeland Security Office of Grants and Training

Senior Officials Workshop for All-Hazards Preparedness

Public Information in a Weapon of Mass Destruction/Terrorism Incident

Mayoral Institute Seminar for All-Hazards Preparedness

### **PROFESSIONAL AFFILIATIONS**

- Florida City County Management Association
- International City/County Management Association

### **EDUCATION**

**Master of Arts in Public Affairs**, concentration Urban Management and Development

Northern Illinois University, De Kalb, Illinois

**Bachelors of Arts, Political Science**, double major - International Relations and Public Law, Russian Minor

Northern Illinois University, De Kalb, Illinois