



CITY COMMISSION

REGULAR MEETING AGENDA

MONDAY, NOVEMBER 18, 2019 AT 6:30 PM

CITY HALL - COMMISSION CHAMBERS
1126 EAST STATE ROAD 434, WINTER SPRINGS, FLORIDA

CALL TO ORDER

Roll Call
Invocation
Pledge of Allegiance
Agenda Changes

AWARDS AND PRESENTATIONS

100. Update on the Cross Seminole Trail
101. UCF Incubator Update
102. Flag Presentation, Boy Scouts
103. 2019 Girls High School State Champions

INFORMATIONAL AGENDA

[200.](#) Current Community Development Projects Summary

Attachments: None

PUBLIC INPUT

Anyone who wishes to speak during Public Input on any Agenda Item or subject matter will need to fill out a "Public Input" form. Individuals will limit their comments to three (3) minutes, and representatives of groups or homeowners' associations shall limit their comments to five (5) minutes, unless otherwise determined by the City Commission.

CONSENT AGENDA

[300.](#) Surplus Assets

Attachments: [Surplus Assets List](#)

[301.](#) FY 2019 Final Budget Amendment

*Attachments: [Resolution 2019-22](#)
[Budget Amendment Detail – General Fund, Other Governmental Funds, Enterprise Funds](#)
[General Fund Budget Amendment Summary](#)*

[302.](#) Award of RFP 07-19KM Landscape Maintenance Services

Attachments: [RFP 07-19KM Landscape Maintenance Services](#)
[Addendum 1](#)
[Addendum 2](#)
[Bid Tabulation](#)
[Bid Tabulation Ranking](#)
[RFP submissions from respondents](#)

[303.](#) Engineering Services for Priority Repairs at City Wastewater Treatment Plants

Attachments: [CPH, Inc. Proposal](#)

[304.](#) Minutes from the Monday, October 14, 2019 City Commission Regular Meeting

Attachments: [Minutes](#)

PUBLIC HEARINGS AGENDA

[400.](#) The Community Development Department requests that the City Commission hold a Public Hearing to consider a Waiver for Northern Oaks, an approved 35-lot single-family residential subdivision.

Attachments: [Vicinity Map](#)
[Waiver Application](#)
[Final Engineering Plan](#)
[Commission Agenda, February 11, 2019](#)
[Letter from City Engineer \(CPH\), October 2, 2019](#)

REGULAR AGENDA

[500.](#) Review Status of Winter Springs Retirement Residence, LLC Development Agreement - The City Commission should review the obligation contained in the Developer's Agreement, dated January 22, 2018, recorded in Seminole County Official Records Book 9105, Pages 264-276, to substantially commence construction of the development project within eighteen (18) months after the Agreement's recording and provide direction regarding a possible extension of the deadline or termination of the Agreement.

Attachments: [Winter Springs Retirement Residence, LLC Development Agreement](#)

[501.](#) Waste Pro Contract Extension

Attachments: [Solid Waste Cost Survey - Seminole County agencies](#)

[502.](#) Reappointment/Appointment Opportunities to the Bicycle and Pedestrian Advisory Committee, Board of Trustees, Code Enforcement Board, and the Parks and Recreation Advisory Committee

Attachments: None

REPORTS

- 600. City Attorney Anthony A. Garganese, Esquire
- 601. City Manager Shawn Boyle
- 602. City Clerk Andrea Lorenzo-Luaces, MMC
- 603. Seat Three Commissioner Ted Johnson
- 604. Seat Four Commissioner TiAnna Hale
- 605. Seat Five Commissioner Geoff Kendrick
- 606. Mayor Charles Lacey
- 607. Seat One Commissioner Jean Hovey
- 608. Seat Two Commissioner/Deputy Mayor Kevin Cannon

PUBLIC INPUT

Anyone who wishes to speak during Public Input on any Agenda Item or subject matter will need to fill out a "Public Input" form. Individuals will limit their comments to three (3) minutes, and representatives of groups or homeowners' associations shall limit their comments to five (5) minutes, unless otherwise determined by the City Commission.

ADJOURNMENT

PUBLIC NOTICE

This is a Public Meeting, and the public is invited to attend and this Agenda is subject to change. Please be advised that one (1) or more Members of any of the City's Advisory Boards and Committees may be in attendance at this Meeting, and may participate in discussions.

Persons with disabilities needing assistance to participate in any of these proceedings should contact the City of Winter Springs at (407) 327-1800 "at least 48 hours prior to meeting, a written request by a physically handicapped person to attend the meeting, directed to the chairperson or director of such board, commission, agency, or authority" - per Section 286.26 *Florida Statutes*.

"If a person decides to appeal any decision made by the board, agency, or commission with respect to any matter considered at such meeting or hearing, he or she will need a record of the proceedings, and that, for such purpose, he or she may need to ensure that a verbatim record of the proceedings is made, which record includes the testimony and evidence upon which the appeal is to be based" - per Section 286.0105 *Florida Statutes*.



INFORMATIONAL AGENDA ITEM 200

CITY COMMISSION AGENDA | NOVEMBER 18, 2019 |
REGULAR MEETING

TITLE

Current Community Development Projects Summary

SUMMARY

CURRENT COMMUNITY DEVELOPMENT PROJECTS SUMMARY			
PROJECT NAME	LOCATION	LAST ACTION ITEM	CURRENT STATUS
AITC Office Building	863 N US 17-92	N/A	DA, Final Engineering & Aesthetic Plans are under Staff review.
Beazer Homes Senior (55+) Condominium Project (The Gatherings at Winter Springs- 108 Units)	Town Center - West side of Tuskawilla, north of Blumberg	Special Exceptions approved by City Commission on 8/13/18. Community Workshop was held on 10/17/19.	DA, Engineering & Aesthetic Plans to be prepared by the developer.
Dream Finders Townhomes (Winter Springs Townhomes) - 114 Units	Town Center - East side of Michael Blake Blvd.	Preliminary Engineering approved by City Commission on 1/8/18.	DA, Final Engineering & Aesthetic Plans are under Staff review.
Insight Partners Inc. (Office and Warehouse Renovation)	300 W SR 434	N/A	Final Engineering Plans are under Staff Review.
Iriye Suites Live Work Community	Town Center	Special Exceptions & Development Agreement approved by City Commission on 1/28/19.	Aesthetic Plans are under Staff review.
Northern Oaks: 35 Single-Family Homes by Dream Finders Homes	North side of SR 434, East of SR 417	Final Engineering & Waivers approved 03/13/17. Aesthetic Review approved 04/9/18. Waiver request recommended for approval by Planning and Zoning Board 10/02/19	Site work complete. Single-Family Homes are under construction. Site Acceptance is pending. Waiver Request.

Southern Oaks: 54 single-family homes	West of DeLeon St. & North of SR 434	Final Engineering, Aesthetic Review, & Development Agreement approved on 6/22/15. Commission accepted site work on 8/14/17.	Site work complete. Single-Family Homes are under construction.
The Studios at Tusawilla	Vistawilla Drive	Community Workshop was held on 07/19/19	DA & Final Engineering Plans are under Staff review.
Tuskawilla Crossings: 379 Single-Family Homes	Town Center	Final Engineering, Development Agreement & Aesthetics approved by City Commission on 4/24/17. Plat approved 8/13/2018. Phase 1 and Phase 2 Site work approved by City Commission.	Site work complete. Single-Family Homes under construction.
Winter Springs Medical Office	E SR 434	Community Workshop was held on 08/13/19	DA, Final Engineering & Aesthetic Plans are under Staff review.
Winter Springs Retirement Residence (Hawthorn ILF): 144 independent living suites	Town Center	Final Engineering, Aesthetic Review, & Development Agreement approved by City Commission on 1/22/18.	Site work under construction.
Winter Springs Town Center Retail Building (Ocean Bleu)	Town Center	Final Engineering & Aesthetic Plans approved by City Commission on 6/10/2019.	Developer to schedule preconstruction meeting prior to starting work.
Wendy's	Town Center	Community Workshop to be scheduled.	DA, Final Engineering & Aesthetic Plans are under Staff review.

For more information please click the link below:

[City of Winter Springs Community Development Projects List/Locations](#)

RECOMMENDATION

Staff recommends the City Commission receive and review the information provided.

Surplus Assets Final List to Commission

Provided by City of Winter Springs

Comission Date	Methods of Disposal
11/18/2019	1 - Auction 6 - Totaled/Accident 2 - eWaste 7 - Lost 3 - Destroy 8 - Stolen 4 - Salvage 9 - Donated 5 - Trade-in 10 - Transfer

Surplus Assets

Departments	Description	Asset #	Serial #	Original Cost	Model #	Method of Disposal
PD	Rion Sound Level Meter	303414	00133098	\$ 1,945	NL-42	3
Parks	Card Printer	303043		\$ 2,489		1
Parks	Red Royal Table	1452		\$ 2,343		1
Parks	Rock Climbing Feature	303751		\$ 3,378		3
Parks	3 Soccer Goals					4
Parks	Bench	303396		\$ 1,012		4
Parks	Bench	303395		\$ 1,012		4
Parks	Bench	303161		\$ 1,107		4
Parks	Bench	303160		\$ 1,107		4
Parks	Air Compressor	307908		\$ 832		4
Parks	Stainless Steel Table	4821				4
Parks	Stainless Steel Table	4822				4



CONSENT AGENDA ITEM 301

CITY COMMISSION AGENDA | NOVEMBER 18, 2019 | REGULAR MEETING

TITLE

FY 2019 Final Budget Amendment

SUMMARY

City Manager is requesting that the Commission consider approval of Resolution 2019-22 amending the Fiscal Year 2018-2019 Budget.

This agenda item is needed to amend the Fiscal Year 2018-2019 budget for those funds which vary from the originally adopted budget. The vast majority of the amendments are necessary for one of the following reasons:

- accrual of revenues and expenses in the appropriate fiscal period
- variations between budgeted (estimated) and actual expenditures and revenues
- 2018-2019 agenda items with fiscal impact

Part of the normal course of operations at fiscal year-end is the accrual of revenues and expenses. The accruals are necessary for aligning revenues and expenses with the fiscal period to which they relate. It is also typical for some variances between actual and budgeted expenses and revenues to require budget adjustments. Furthermore, over the course of the fiscal year, various agenda items are approved by the Commission. In some cases, those approved agenda items lack specific language to amend the expenditure budget or the appropriation to or from fund balance. This resolution formalizes the fiscal impact of those actions.

This budget amendment also provides for transfer to #140 Arbor Fund for future plantings and forestation projects (\$300K), transfer to #303 Perk Up Parks for future park initiatives (\$1M), transfer to #305 Capital Project Fund for end-of-life asset replacement and City facility renovations (\$200K), and an additional contribution toward the unfunded pension liability (\$300K).

The City Charter provides that the Commission may amend the budget by resolution. Please note that only those funds requiring budget adjustment are included herein. Shown in Attachment B are the budgeted ending fund balances for all funds requiring amendment for the 2018-2019 fiscal year. Please note: these are budgeted figures only, not to be confused with audited financial statements which will be available in March of 2020. State statute requires that the final budget amendment be formalized by November 29, 2019.

RECOMMENDATION

Staff recommends approval of Resolution 2019-22.

RESOLUTION 2019-22

A RESOLUTION OF THE CITY COMMISSION OF THE CITY OF WINTER SPRINGS FLORIDA, AMENDING THE FISCAL YEAR 2018-2019 BUDGET; PROVIDING FOR SEVERABILITY, REPEAL OF PRIOR INCONSISTENT RESOLUTIONS, AND AN EFFECTIVE DATE.

WHEREAS, Section 7.05 of the City Charter provides that the annual City budget may be amended by Resolution duly adopted by the Commission; and

WHEREAS, the City Commission of the City of Winter Springs deems that this Resolution is in the best interests of the public health, safety, and welfare of the citizens of Winter Springs.

NOW, THEREFORE, BE IT RESOLVED BY THE CITY COMMISSION OF THE CITY OF WINTER SPRINGS, SEMINOLE COUNTY, FLORIDA, AS FOLLOWS:

Section 1. Incorporation of Recitals. The foregoing recitals are deemed true and correct and are hereby fully incorporated by this reference.

Section 2. That the Fiscal Year 2018-2019 City Budgets are amended as provided in Attachments B and C attached hereto.

Section 3. Repeal of Prior Inconsistent Resolutions. All prior resolutions or parts of resolutions in conflict herewith are hereby repealed to the extent of the conflict.

Section 4. Severability. If any section, subsection, sentence, clause, phrase, word, or portion of this Resolution is for any reason held invalid or unconstitutional by any court of competent jurisdiction, such portion shall be deemed a separate, distinct and independent provision and such holding shall not affect the validity of the remaining portion hereto.

Section 5. Effective Date. This Resolution shall become effective immediately upon adoption by the City Commission of the City of Winter Springs, Florida.

RESOLVED by the City Commission of the City of Winter Springs, Florida, in a regular meeting assembled on the 18th day of November, 2019.

CHARLES LACEY, Mayor

ATTEST:

ANDREA LORENZO-LUACES, City Clerk

**Approved as to legal form and sufficiency for
the City of Winter Springs only:**

ANTHONY A. GARGANESE, City Attorney

Attachment B - Budget Amendment Detail

Resolution 2019-22

General Fund

Funds not included in this summary do not require budget amendment

HELPFUL TOOLS: Comprehensive Annual Financial Report for the year ended September 30, 2018 as approved by City Commission on 5/13/2019
 Regular 500; Fiscal Year 2018-2019 Original Budget as approved by City Commission on 9/24/18 Public Hearing 501.

Difference in Beg Fund Bal Projected to Actual	Actual Beg Fund Balance 9/30/18 CAFR
--	--

General Fund #001:

As approved by City Commission on 9/24/18 Public Hearing Item 501:

10/1/18 Budgeted Beginning Fund Balance	\$8,509,235	\$5,192	\$8,514,427
FY 2019 Budgeted Appropriation to (FROM) Fund Balance	\$1,499		
9/30/19 Budgeted Ending Fund Equity	<u>\$8,510,734</u>		

Amendments to be approved tonight to Original FY 2018-2019 Budget (as approved on 9/24/18):

Difference in Beginning Fund Balance FROM projected to actual as shown in 9/30/18 CAFR	<u>\$5,192</u>
--	----------------

Revenue Neutral:

Grants/Donations:

HIDTA grant revenues - 100% Reimb vehicle lease	\$7,080	mid-yr
HIDTA grant expenditures - vehicle lease (2110)	(\$7,080)	mid-yr
Byrne grant revenues - gun locks	\$17,535	mid-yr
Byrne grant expenditure - gun locks (2130)	(\$17,535)	mid-yr
Babe Ruth Donation - Consent 300; 2.11.19 windscreens	\$5,771	mid-yr
Consent 300; 2.11.19 windscreen expenditure budget (7230)	(\$5,771)	mid-yr
Donations - Canine (Tuscawilli HOA, Edward Lund)	\$4,000	final
Expenditure budget - Canine (2100)	(\$4,000)	final
	<u>\$0</u>	

Community Events:

Community Event Revenue - Spring Festival - escrow draw	\$1,238	mid-yr
Community Event Revenue - Spring Festival	\$7,150	mid-yr
Community Event Expenditure - Spring Festival (7400)	(\$8,388)	mid-yr
Community Event Revenue - Winter Wonderland - escrow draw	\$2,983	mid-yr
Community Event Revenue - Winter Wonderland	\$6,267	mid-yr
Community Event Expenditure - Winter Wonderland (7400)	(\$9,250)	mid-yr
Community Event Revenue - Hometown Harvest	\$9,450	mid-yr
Community Event Expenditure - Hometown Harvest (7400)	(\$9,450)	mid-yr
Community Event Revenue - July 4th	\$30,930	mid-yr
Community Event Expenditure - July 4th (7400)	(\$30,930)	mid-yr
	<u>\$0</u>	

Insurance/Recycling/Trade-In:

Insurance proceeds - traffic accident	\$1,763	mid-yr
Expenditure budget for property damage (1520)	(\$1,763)	mid-yr
Insurance proceeds - traffic accident	\$3,894	mid-yr
Expenditure budget for property damage (2100)	(\$3,894)	mid-yr
	<u>\$0</u>	

Other:

Increase General Fund revenue budget (various - grants, investment income, etc)	\$138,000	mid-yr
Parks - Torcaso improvements, basketball court replacement/expansion (7230)	(\$138,000)	mid-yr
Increase transfers in from fund 201 - residual equity transfer	\$9,108	mid-yr
Remove transfer out to fund 201 - debt service instrument fully retired (1900)	\$10,000	mid-yr
Reimburse contingency account (1900)	(\$19,108)	mid-yr
Increase General Fund electricity tax - utilize for grapple truck purchase; Consent 300; 9.9.19	\$167,000	final
Establish capital budget for grapple truck purchase; Consent 300; 9.9.19	(\$167,000)	final
Increase General Fund revenue budget (multiple - elect franch, FEMA, rev sharing, invst, etc.)	\$565,000	final
Establish transfer budget to Perk Up Parks CP Fund #303 for future park initiatives (7230)	(\$565,000)	final
	<u>\$0</u>	

Inter-departmental transfers:

Inter-departmental transfer FROM Dep't 13 Finance - vacancy (1300)	\$25,000	mid-yr
Inter-departmental transfer TO Dep't 12 City Manager - vacation payout (1200)	(\$25,000)	mid-yr
Inter-departmental transfer FROM Dep't 13 Finance - vacancy (1300)	\$33,840	mid-yr
Inter-departmental transfer TO Dep't 12 Commission - redistricting, Promo CM (1100)	(\$8,215)	mid-yr
Inter-departmental transfer TO Dep't 12 City Clerk - codification (1200)	(\$625)	mid-yr
Inter-departmental transfer TO Dep't 41 Public Works - CH renovation materials, small tools (1930)	(\$25,000)	mid-yr
Inter-departmental transfer FROM Dep't 21 Police - vacancies (2100)	\$200,000	mid-yr
Inter-departmental transfer FROM Dep't 19 Gen Gov't - contingency reduction (1900)	\$58,000	mid-yr
Inter-departmental transfer TO Dep't 15 Com Dev - case study, visioning, econ dev, staff assistance (1500)	(\$96,000)	mid-yr
Inter-departmental transfer TO Dep't 15 Com Dev - urban beautification (1520)	(\$50,000)	mid-yr
Inter-departmental transfer TO Dep't 72 - Torcaso improvements (7230)	(\$47,000)	mid-yr
Inter-departmental transfer TO Dep't 72 - dehumidifier (7250)	(\$65,000)	mid-yr
Inter-departmental transfer FROM Dep't 16 Info Svcs - payroll, maint agreements (1600)	\$37,000	final
Inter-departmental transfer TO Dep't 22 for pension funding (2200)	(\$27,000)	final
Inter-departmental transfer TO Dep't 12 for retirement (1200)	(\$10,000)	final
Inter-departmental transfer FROM Dep't 19 Gen Gov't - contingency (1900)	\$130,000	final
Inter-departmental transfer FROM Dep't 41 Public Works - payroll (4100, 4110)	\$85,000	final
Inter-departmental transfer TO Dep't 72 Parks - t.fer to Perk Up Parks Capital Projects (7230)	(\$215,000)	final
Inter-departmental transfer FROM Dep't 21 Police - payroll (2100, 2140)	\$250,000	final
Inter-departmental transfer TO Dep't 15 Com Dev - transfer to Arbor (1520)	(\$250,000)	final
	<u>\$0</u>	

Revisions to Original Budgeted Appropriation to (FROM) Fund Balance	<u>\$0</u>
--	------------

REVISED 9/30/19 Budgeted Ending Fund Balance	<u>\$8,515,926</u>
---	---------------------------

Attachment B - Budget Amendment Detail

Resolution 2019-22
Other Governmental Funds

HELPFUL TOOLS: Comprehensive Annual Financial Report for the year ended September 30, 2018 as approved by City Commission on 5/13/2019 Regular 500; Fiscal Year 2018-2019 Original Budget as approved by City Commission on 9/24/18 Public Hearing 501.

Difference in Beg Fund Bal Projected to Actual	Actual Beg Fund Balance 9/30/18 CAFR
---	--

Special Law Enforcement Fund - Local #102

As approved by City Commission on 9/24/18 Public Hearing Item 501:

10/1/18 Budgeted Beginning Fund Balance	\$20,499	\$1,131	\$21,630
FY 2019 Budgeted Appropriation to (from) Fund Balance	(19,975)		
9/30/19 Budgeted Ending Fund Balance	<u>\$524</u>		

Amendments to be approved tonight to Original FY 2018-2019 Budget (as approved on 9/24/18):

Difference in Beginning Fund Balance FROM projected to actual as shown in 9/30/18 CAFR	\$1,131		
Decrease small tools budget	\$6,500	mid-yr	
Revisions to Original Budgeted Appropriation to (from) Fund Balance	<u>\$7,631</u>		
REVISED 9/30/19 Budgeted Ending Fund Balance	<u>\$8,155</u>		

Special Law Enforcement Trust Fund - Federal #103

As approved by City Commission on 9/24/18 Public Hearing Item 501:

10/1/18 Budgeted Beginning Fund Balance	\$43,423	\$16,066	\$59,489
FY 2019 Budgeted Appropriation to (from) Fund Balance	(40,189)		
9/30/19 Budgeted Ending Fund Balance	<u>\$3,234</u>		

Amendments to be approved tonight to Original FY 2018-2019 Budget (as approved on 9/24/18):

Difference in Beginning Fund Balance FROM projected to actual as shown in 9/30/18 CAFR	\$16,066		
Increase confiscated property revenues to reflect YTD actuals (DOJ)	\$24,540	mid-yr/final	
Revisions to Original Budgeted Appropriation to (from) Fund Balance	<u>\$40,606</u>		
REVISED 9/30/19 Budgeted Ending Fund Balance	<u>\$43,840</u>		

Transportation Improvement Fund #120

As approved by City Commission on 9/24/18 Public Hearing Item 501:

10/1/18 Budgeted Beginning Fund Balance	\$1,559,972	\$299,804	\$1,859,776
FY 2019 Budgeted Appropriation to (from) Fund Balance	(354,600)		
9/30/19 Budgeted Ending Fund Balance	<u>\$1,205,372</u>		

Amendments to be approved tonight to Original FY 2018-2019 Budget (as approved on 9/24/18):

Difference in Beginning Fund Balance FROM projected to actual as shown in 9/30/18 CAFR	\$299,804		
Net capital budget reduction (defer vehicles, resurfacing)	\$164,200	mid-yr	
Revisions to Original Budgeted Appropriation to (from) Fund Balance	<u>\$464,004</u>		
REVISED 9/30/19 Budgeted Ending Fund Balance	<u>\$1,669,376</u>		

Attachment B - Budget Amendment Detail

Resolution 2019-22
Other Governmental Funds

HELPFUL TOOLS: Comprehensive Annual Financial Report for the year ended September 30, 2018 as approved by City Commission on 5/13/2019 Regular 500; Fiscal Year 2018-2019 Original Budget as approved by City Commission on 9/24/18 Public Hearing 501.

Difference in Beg Fund Bal Projected to Actual	Actual Beg Fund Balance 9/30/18 CAFR
---	--

Road Improvements Fund #121

As approved by City Commission on 9/24/18 Public Hearing Item 501:

10/1/18 Budgeted Beginning Fund Balance	\$5,480,080	\$1,362,426	\$6,842,506
FY 2019 Budgeted Appropriation to (from) Fund Balance	(\$1,757,214)		
9/30/19 Budgeted Ending Fund Balance	<u>\$3,722,866</u>		

Amendments to be approved tonight to Original FY 2018-2019 Budget (as approved on 9/24/18):

Difference in Beginning Fund Balance FROM projected to actual as shown in 9/30/18 CAFR	\$1,362,426		
Reduce CRA reimbursement due to reduction in scope - Florida Ave (2nd Gen)	(\$53,313)	mid-yr	
PO Rollover 2018-759 Fausnight - Thermoplastic City logo	(\$58,918)	mid-yr	
Consent 302; 12.10.18 - Town Center Parking Lot (2nd Gen)	(\$480,025)	mid-yr	
Defer transfer to the 1999 Construction Fund - Magnolia Amphitheater (2nd Gen)	\$212,000	mid-yr	
Defer capital budget for bridge infrastructure (3rd Gen)	\$275,000	mid-yr	
Defer transfer to Fund 303 for field house (3rd Gen)	\$3,000,000	mid-yr	
Revisions to Original Budgeted Appropriation to (from) Fund Balance	<u>\$4,257,170</u>		

REVISED 9/30/19 Budgeted Ending Fund Balance

\$7,980,036

Solid Waste/Recycling Fund #130

As approved by City Commission on 9/24/18 Public Hearing Item 501:

10/1/18 Budgeted Beginning Fund Balance	\$1,022,275	\$356,301	\$1,378,576
FY 2019 Budgeted Appropriation to (from) Fund Balance	(\$175,490)		
9/30/19 Budgeted Ending Fund Balance	<u>\$846,785</u>		

Amendments to be approved tonight to Original FY 2018-2019 Budget (as approved on 9/24/18):

Difference in Beginning Fund Balance FROM projected to actual as shown in 9/30/18 CAFR	\$356,301		
Recognize add'l investment earnings	\$44,000	final	
Increase expenditure budget (NRCS grant City match, admin costs, landfill)	(\$9,000)	final	
Revisions to Original Budgeted Appropriation to (from) Fund Balance	<u>\$391,301</u>		

REVISED 9/30/19 Budgeted Ending Fund Balance

\$1,238,086

Arbor Fund #140

As approved by City Commission on 9/24/18 Public Hearing Item 501:

10/1/18 Budgeted Beginning Fund Balance	\$271,981	\$307,406	\$579,387
FY 2019 Budgeted Appropriation to (from) Fund Balance	(\$266,813)		
9/30/19 Budgeted Ending Fund Balance	<u>\$5,168</u>		

Amendments to be approved tonight to Original FY 2018-2019 Budget (as approved on 9/24/18):

Difference in Beginning Fund Balance FROM projected to actual as shown in 9/30/18 CAFR	\$307,406		
Increase arbor revenue budget to reflect YTD actuals	\$137,500	mid-yr	
Transfer from General Fund for urban beautification projects	\$300,000	final	
Revisions to Original Budgeted Appropriation to (from) Fund Balance	<u>\$744,906</u>		

REVISED 9/30/19 Budgeted Ending Fund Balance

\$750,074

Attachment B - Budget Amendment Detail

Resolution 2019-22
Other Governmental Funds

HELPFUL TOOLS: Comprehensive Annual Financial Report for the year ended September 30, 2018 as approved by City Commission on 5/13/2019 Regular 500; Fiscal Year 2018-2019 Original Budget as approved by City Commission on 9/24/18 Public Hearing 501.

	Difference in Beg Fund Bal Projected to Actual	Actual Beg Fund Balance 9/30/18 CAFR
--	---	--

Transportation Impact Fee Fund #150

As approved by City Commission on 9/24/18 Public Hearing Item 501:

10/1/18 Budgeted Beginning Fund Balance	\$853,724	\$252,933	\$1,106,657
FY 2019 Budgeted Appropriation to (from) Fund Balance	<u>(\$846,750)</u>		
9/30/19 Budgeted Ending Fund Balance	<u>\$6,974</u>		

Amendments to be approved tonight to Original FY 2018-2019 Budget (as approved on 9/24/18):

Difference in Beginning Fund Balance FROM projected to actual as shown in 9/30/18 CAFR	\$252,933		
Increase impact fee revenue budget to reflect YTD actuals (residential and commercial)	\$197,250	mid-yr	
Increase investment revenue budget to reflect YTD actuals	\$8,000	mid-yr	
Defer FY 2019 project budgets, excluding design/engineering costs	\$750,000	mid-yr	

Revisions to Original Budgeted Appropriation to (from) Fund Balance

\$1,208,183

REVISED 9/30/19 Budgeted Ending Fund Balance

\$1,215,157

Police Impact Fee Fund #151

As approved by City Commission on 9/24/18 Public Hearing Item 501:

10/1/18 Budgeted Beginning Fund Balance	\$539,682	\$9,042	\$548,724
FY 2019 Budgeted Appropriation to (from) Fund Balance	<u>\$5,000</u>		
9/30/19 Budgeted Ending Fund Balance	<u>\$544,682</u>		

Amendments to be approved tonight to Original FY 2018-2019 Budget (as approved on 9/24/18):

Difference in Beginning Fund Balance FROM projected to actual as shown in 9/30/18 CAFR	\$9,042		
Increase impact fee revenue budget to reflect YTD actuals (residential and commercial)	\$46,500	mid-yr	
Revisions to Original Budgeted Appropriation to (from) Fund Balance	<u>\$55,542</u>		

REVISED 9/30/19 Budgeted Ending Fund Balance

\$600,224

Fire Impact Fee Fund #152

As approved by City Commission on 9/24/18 Public Hearing Item 501:

10/1/18 Budgeted Beginning Fund Balance	\$2,421,090	\$22,208	\$2,443,298
FY 2019 Budgeted Appropriation to (from) Fund Balance	<u>\$25,000</u>		
9/30/19 Budgeted Ending Fund Balance	<u>\$2,446,090</u>		

Amendments to be approved tonight to Original FY 2018-2019 Budget (as approved on 9/24/18):

Difference in Beginning Fund Balance FROM projected to actual as shown in 9/30/18 CAFR	\$22,208		
Increase impact fee revenue budget to reflect YTD actuals (residential)	\$22,800	mid-yr	
Revisions to Original Budgeted Appropriation to (from) Fund Balance	<u>\$45,008</u>		

REVISED 9/30/19 Budgeted Ending Fund Balance

\$2,491,098

Attachment B - Budget Amendment Detail

Resolution 2019-22
Other Governmental Funds

HELPFUL TOOLS: Comprehensive Annual Financial Report for the year ended September 30, 2018 as approved by City Commission on 5/13/2019
Regular 500; Fiscal Year 2018-2019 Original Budget as approved by City Commission on 9/24/18 Public Hearing 501.

	Difference in Beg Fund Bal Projected to Actual	Actual Beg Fund Balance 9/30/18 CAFR
--	---	--

Park Impact Fee Fund #153

As approved by City Commission on 9/24/18 Public Hearing Item 501:

10/1/18 Budgeted Beginning Fund Balance	\$1,103,112	\$298,287	\$1,401,399
FY 2019 Budgeted Appropriation to (from) Fund Balance	(\$538,000)		
9/30/19 Budgeted Ending Fund Balance	\$565,112		

Amendments to be approved tonight to Original FY 2018-2019 Budget (as approved on 9/24/18):

Difference in Beginning Fund Balance FROM projected to actual as shown in 9/30/18 CAFR	\$298,287		
PO Rollover from Consent 301; 4.9.18 Trotwood Pavilion	(\$243,540)	mid-yr	
Trotwood Pavilion - supplemental appropriation for park enhancements	(\$150,000)	mid-yr	
Consent 300; 6.10.19; Fitness Zone expenditure budget - Trotwood	(\$60,000)	mid-yr	
Defer Torcaso projects (pavilion, dock, walkway)	\$550,000	mid-yr	
Increase impact fee revenue budget to reflect YTD actuals (residential)	\$592,000	mid-yr/final	
Increase investment revenue	\$42,000	final	
Reclass FY19 new playground expenditures from fund #303; impact fee eligible and FY19 revenues support it	(\$780,000)	final	
Revisions to Original Budgeted Appropriation to (from) Fund Balance	\$248,747		
REVISED 9/30/19 Budgeted Ending Fund Balance	\$813,859		

Oak Forest Maintenance Fund #161

As approved by City Commission on 9/24/18 Public Hearing Item 501:

10/1/18 Budgeted Beginning Fund Balance	\$72,537	\$19,430	\$91,967
FY 2019 Budgeted Appropriation to (from) Fund Balance	\$1,962		
9/30/19 Budgeted Ending Fund Balance	\$74,499		

Amendments to be approved tonight to Original FY 2018-2019 Budget (as approved on 9/24/18):

Difference in Beginning Fund Balance FROM projected to actual as shown in 9/30/18 CAFR	\$19,430		
Residual Equity Transfer from Oak Forest DS Fund	\$3,885	mid-yr	
Increase landscape budget due to partial year with temporary vendor	(\$8,000)	final	
Increase investment revenue budget to reflect YTD actuals	\$2,000	final	
Revisions to Original Budgeted Appropriation to (from) Fund Balance	\$17,315		
REVISED 9/30/19 Budgeted Ending Fund Balance	\$91,814		

Tusawilla III Assessment Area Fund #162

As approved by City Commission on 9/24/18 Public Hearing Item 501:

10/1/18 Budgeted Beginning Fund Balance	\$6,214	\$4,044	\$10,258
FY 2019 Budgeted Appropriation to (from) Fund Balance	(\$1,907)		
9/30/19 Budgeted Ending Fund Balance	\$4,307		

Amendments to be approved tonight to Original FY 2018-2019 Budget (as approved on 9/24/18):

Difference in Beginning Fund Balance FROM projected to actual as shown in 9/30/18 CAFR	\$4,044		
Add'l landscape needs (maint division)	(\$1,955)	mid-yr	
Revisions to Original Budgeted Appropriation to (from) Fund Balance	\$2,089		
REVISED 9/30/19 Budgeted Ending Fund Balance	\$6,396		

Attachment B - Budget Amendment Detail

Resolution 2019-22
Other Governmental Funds

HELPFUL TOOLS: Comprehensive Annual Financial Report for the year ended September 30, 2018 as approved by City Commission on 5/13/2019
Regular 500; Fiscal Year 2018-2019 Original Budget as approved by City Commission on 9/24/18 Public Hearing 501.

	Difference in Beg Fund Bal Projected to Actual	Actual Beg Fund Balance 9/30/18 CAFR
--	---	--

2003 Debt Service Fund #201

As approved by City Commission on 9/24/18 Public Hearing Item 501:

10/1/18 Budgeted Beginning Fund Balance	\$837,007	\$4,061	\$841,068
FY 2019 Budgeted Appropriation to (from) Fund Balance	(\$828,160)		
9/30/19 Budgeted Ending Fund Balance	\$8,847		

Amendments to be approved tonight to Original FY 2018-2019 Budget (as approved on 9/24/18):

Difference in Beginning Fund Balance FROM projected to actual as shown in 9/30/18 CAFR	\$4,061		
Increase investment revenue	\$4,700	mid-yr	
Decrease arbitrage expense for potential need related to the 2011/2014 Imp Ref Rev Note	\$1,500	mid-yr	
Decrease transfer in from General Fund	(\$10,000)	mid-yr	
Increase transfer to the General Fund - estimated residual equity transfer	(\$9,108)	mid-yr	

Revisions to Original Budgeted Appropriation to (from) Fund Balance

(\$8,847)

REVISED 9/30/19 Budgeted Ending Fund Balance

\$0

1999/2011 Debt Service Fund #202

As approved by City Commission on 9/24/18 Public Hearing Item 501:

10/1/18 Budgeted Beginning Fund Balance	\$235,099	\$996	\$236,095
FY 2019 Budgeted Appropriation to (from) Fund Balance	\$610,055		
9/30/19 Budgeted Ending Fund Balance	\$845,154		

Amendments to be approved tonight to Original FY 2018-2019 Budget (as approved on 9/24/18):

Difference in Beginning Fund Balance FROM projected to actual as shown in 9/30/18 CAFR	\$996		
Decrease interest expense to reflect updated amortization schedule	\$428,564	mid-yr	
Increase arbitrage expense for potential need related to the 1999 Series bonds	(\$1,500)	mid-yr	

Revisions to Original Budgeted Appropriation to (from) Fund Balance

\$428,060

REVISED 9/30/19 Budgeted Ending Fund Balance

\$1,273,214

Oak Forest Debt Service Fund #260

As approved by City Commission on 9/24/18 Public Hearing Item 501:

10/1/18 Budgeted Beginning Fund Balance	\$5,897	\$2,602	\$8,499
FY 2019 Budgeted Appropriation to (from) Fund Balance	(\$5,897)		
9/30/19 Budgeted Ending Fund Balance	\$0		

Amendments to be approved tonight to Original FY 2018-2019 Budget (as approved on 9/24/18):

Difference in Beginning Fund Balance FROM projected to actual as shown in 9/30/18 CAFR	\$2,602		
Increase transfer budget - debt has been fully retired, residual equity to be transferred to Oak Forest Maintenance Fund	(\$2,672)	mid-yr	
Increase investment revenue budget	\$70	mid-yr	

Revisions to Original Budgeted Appropriation to (from) Fund Balance

\$0

REVISED 9/30/19 Budgeted Ending Fund Balance

\$0

Attachment B - Budget Amendment Detail

Resolution 2019-22
Other Governmental Funds

HELPFUL TOOLS: Comprehensive Annual Financial Report for the year ended September 30, 2018 as approved by City Commission on 5/13/2019
Regular 500; Fiscal Year 2018-2019 Original Budget as approved by City Commission on 9/24/18 Public Hearing 501.

Difference in Beg Fund Bal Projected to Actual	Actual Beg Fund Balance 9/30/18 CAFR
---	--

TLBD I Capital/Debt Service Fund #261

As approved by City Commission on 9/24/18 Public Hearing Item 501:

10/1/18 Budgeted Beginning Fund Balance	\$72,891	\$38,367	\$111,258
FY 2019 Budgeted Appropriation to (from) Fund Balance	\$50		
9/30/19 Budgeted Ending Fund Balance	\$72,941		

Amendments to be approved tonight to Original FY 2018-2019 Budget (as approved on 9/24/18):

Difference in Beginning Fund Balance FROM projected to actual as shown in 9/30/18 CAFR	\$38,367		
Consent 301; 8.12.19; Fountain landscape upgrades	(\$36,000)	final	
Revisions to Original Budgeted Appropriation to (from) Fund Balance	\$2,367		

REVISED 9/30/19 Budgeted Ending Fund Balance

\$75,308

1999 Construction Capital Project Fund #301

As approved by City Commission on 9/24/18 Public Hearing Item 501:

10/1/18 Budgeted Beginning Fund Balance	\$826,259	\$15,218	\$841,477
FY 2019 Budgeted Appropriation to (from) Fund Balance	(\$795,800)		
9/30/19 Budgeted Ending Fund Balance	\$30,459		

Amendments to be approved tonight to Original FY 2018-2019 Budget (as approved on 9/24/18):

Difference in Beginning Fund Balance FROM projected to actual as shown in 9/30/18 CAFR	\$15,218		
Defer transfer budget from Road Imp Fund - Magnolia Park	(\$212,000)	mid-yr	
Defer capital expenditure budget - Magnolia Park	\$940,000	mid-yr	
Revisions to Original Budgeted Appropriation to (from) Fund Balance	\$743,218		

REVISED 9/30/19 Budgeted Ending Fund Balance

\$773,677

Perk Up Parks Capital Project Fund #303

As approved by City Commission on 9/24/18 Public Hearing Item 501:

10/1/18 Budgeted Beginning Fund Balance	\$568,934	\$1,565,000	\$2,133,934
FY 2019 Budgeted Appropriation to (from) Fund Balance	(\$492,200)		
9/30/19 Budgeted Ending Fund Balance	\$76,734		

Amendments to be approved tonight to Original FY 2018-2019 Budget (as approved on 9/24/18):

Difference in Beginning Fund Balance FROM projected to actual as shown in 9/30/18 CAFR	\$1,565,000		
Defer transfer in from Infrastructure Surtax (3rd Gen) for fieldhouse	(\$3,000,000)	mid-yr	
Reduce capital budget related to the proposed field house project	\$3,500,000	mid-yr	
Increase themed playground budgets (sidewalks, lighting, landscaping, etc.)	(\$500,000)	mid-yr	
Increase transfer budget from General Fund for future park initiative/projects	\$1,000,000	final	

Revisions to Original Budgeted Appropriation to (from) Fund Balance

\$2,565,000

REVISED 9/30/19 Budgeted Ending Fund Balance

\$2,641,734

Attachment B - Budget Amendment Detail

Resolution 2019-22

Other Governmental Funds

HELPFUL TOOLS: Comprehensive Annual Financial Report for the year ended September 30, 2018 as approved by City Commission on 5/13/2019 Regular 500; Fiscal Year 2018-2019 Original Budget as approved by City Commission on 9/24/18 Public Hearing 501.

Difference in Beg Fund Bal Projected to Actual	Actual Beg Fund Balance 9/30/18 CAFR
---	--

Excellence in Customer Service Initiative CP Fund #305

at 9.30.18	\$1,424,708
Receivable	(\$965,000)

As approved by City Commission on 9/24/18 Public Hearing Item 501:

10/1/18 Budgeted Beginning Fund Balance	\$204,248	\$255,460	\$459,708
FY 2019 Budgeted Appropriation to (from) Fund Balance	(\$33,200)		'Spendable' FB
9/30/19 Budgeted Ending Fund Balance	\$171,048		

Amendments to be approved tonight to Original FY 2018-2019 Budget (as approved on 9/24/18):

Difference in Beginning Fund Balance FROM projected to actual as shown in 9/30/18 CAFR	\$255,460		
PO Rollover - 2018-1928 Morton Construction (Quick Pay Kiosk)	(\$67,598)	mid-yr	
Increase capital budget (City Hall e-sign, landscape, doors, Civic Rec software, signage, etc.)	(\$55,250)	mid-yr	
Transfer from General Fund for end-of-life asset replacement and facility renovations	\$200,000	final	

Revisions to Original Budgeted Appropriation to (from) Fund Balance	\$332,612
---	------------------

REVISED 9/30/19 Budgeted Ending Fund Balance	\$503,660
---	------------------

Attachment B - Budget Amendment Detail

Resolution 2019-22

Enterprise Funds

HELPFUL TOOLS: Comprehensive Annual Financial Report for the year ended September 30, 2018 as approved by City Commission on 5/13/2019 Regular 500; Fiscal Year 2018-2019 Original Budget as approved by City Commission on 9/24/18 Public Hearing 501.

Net Capital, Restricted, NPL	Difference in Beg Fund Bal - Projected to Actual	Actual Ending Fund Equity 9/30/18 CAFR
---------------------------------	--	--

HELPFUL TOOLS: Comprehensive Annual Financial Report for the year ended September 30, 2018 as approved by City Commission on 5/13/2019 Regular 500; Fiscal Year 2018-2019 Original Budget as approved by City Commission on 9/24/18 Public Hearing 501.

Actual Beg Fund Balance 9/30/18 CAFR
--

Stormwater Utility Fund #411

Amendments to be approved tonight to Original FY 2018-2019 Budget (as approved on 9/24/18):

10/1/18 Budgeted Beginning Fund Equity	\$504,161	\$6,899,467	\$261,890	\$7,665,518
FY 2019 Budgeted Appropriation to (from) Fund Equity	(\$74,282)			
9/30/19 Budgeted Ending Fund Equity	<u>\$429,879</u>			

REVISED 9/30/19 Budgeted Ending Fund Equity

Amendments to be approved tonight to Original FY 2018-2019 Budget (as approved on 9/24/18):

Difference in Beginning Fund Equity for budgeting purposes projected to actual	\$261,890			
Establish NRCS Emergency Watershed grant revenue for initial consulting (100% reimbursement)	\$143,057	mid-yr		
PO Rollover - 2018-1987 CDM Technical Assistance Establish NRCS Emergency Watershed grant expenditure budget for initial consulting costs	(\$133,353)	mid-yr		
Insurance proceeds - traffic accident	\$2,725	mid-yr		
Expenditure budget for property damage	(\$2,725)	mid-yr		
Revisions to Original Budgeted Appropriation to (from) Fund Equity	<u>\$404,947</u>			

REVISED 9/30/19 Budgeted Ending Fund Equity (excl of net capital, restricted, NPL)

\$834,826

Water and Sewer Service Availability Fund #412:

As approved by City Commission on 9/24/18 Public Hearing Item 501:

10/1/16 Budgeted Beginning Fund Equity	\$4,864,479	\$0	\$139,590	\$5,004,069
FY 2019 Budgeted Appropriation to (from) Fund Equity	\$40,000			
9/30/19 Budgeted Ending Fund Equity	<u>\$4,904,479</u>			

Amendments to be approved tonight to Original FY 2018-2019 Budget (as approved on 9/24/18):

Difference in Beginning Fund Equity for budgeting purposes projected to actual	\$139,590			
Service Availability revenue budget	\$397,000	mid-yr		
Revisions to Original Budgeted Fund Equity	<u>\$536,590</u>			

REVISED 9/30/19 Budgeted Ending Fund Equity (excl of net capital, restricted, NPL)

\$5,441,069

Attachment C - General Fund Budget Amendment Summary

Resolution 2019-22

HELPFUL TOOLS: Comprehensive Annual Financial Report for the year ended September 30, 2018 as approved by City Commission on 5/13/2019 Regular 500; Fiscal Year 2018-2019 Original Budget as approved by City Commission on 9/24/18 Public Hearing 501.

<u>Division #</u>	<u>FY 19 Original Annual Budget</u>	<u>Revenue Neutral Changes</u>	<u>Other Requests to Amend Appropriation</u>	<u>Inter/Intra Departmental Transfers</u>	<u>FY 19 Amended Annual Budget</u>
General Fund Revenues & Transfers:	\$ 18,579,399				\$ 18,579,399
Transfer in budget from 201 - residual equity			\$ 9,108		\$ 9,108
Community Event revenue budget	\$ 53,797	\$ 53,797			\$ 53,797
Community Event - escrow draw	\$ 4,221	\$ 4,221			\$ 4,221
HIDTA grant revenue - vehicle lease	\$ 7,080	\$ 7,080			\$ 7,080
Byrne grant revenue - gun locks	\$ 17,535	\$ 17,535			\$ 17,535
Babe Ruth donation	\$ 5,771	\$ 5,771			\$ 5,771
Increase grant, investment revenue budget			\$ 138,000		\$ 138,000
Donations - K9	\$ 4,000	\$ 4,000			\$ 4,000
Increase elect tax per Consent 300; 9.9.19	\$ 167,000	\$ 167,000			\$ 167,000
Inurance proceeds	\$ 5,657	\$ 5,657			\$ 5,657
Increase elect. franchise, rev sharing , FEMA, etc.			\$ 565,000		\$ 565,000
General Fund Revenues & Transfers	\$ 18,579,399	\$ 265,061	\$ 712,108	\$ -	\$ 19,556,568
General Fund Expenditures:					
City Commission	1100 \$ 116,260			\$ 11,654	\$ 127,914
City Manager	1200 \$ 291,092			\$ 45,000	\$ 336,092
City Clerk	1210 \$ 268,771			\$ (12,814)	\$ 255,957
General Government - Legal Services	1400 \$ 246,000				\$ 246,000
General Government - General	1900 \$ 2,136,206		\$ 9,108	\$ (188,000)	\$ 1,957,314
Finance & Admin Services - General	1300 \$ 635,763			\$ (65,463)	\$ 570,300
Finance & Admin Services - Human Resources	1310 \$ 172,187			\$ 6,623	\$ 178,810
Finance & Admin Services - Utility Billing	1360 \$ 589,718				\$ 589,718
Finance & Admin Services - Risk Management	1920 \$ 480,200				\$ 480,200
Information Systems - General	1600 \$ 746,049			\$ (37,000)	\$ 709,049
Information Systems - City Hall	1910 \$ 32,988				\$ 32,988
Comm Development - Administration	1500 \$ 153,426			\$ 59,750	\$ 213,176
Comm Development - Planning	1510 \$ 75,444			\$ (6,200)	\$ 69,244
Comm Development - Urban Beautification	1520 \$ 652,960	\$ 1,763		\$ 342,450	\$ 997,173
Comm Development - Streetlighting	1530 \$ 523,440				\$ 523,440
Police - Chief	2100 \$ 6,288,940	\$ 7,894		\$ (417,289)	\$ 5,879,545
Police - Criminal Investigations	2110 \$ 18,175	\$ 7,080			\$ 25,255
Police - Operations Support	2120 \$ 14,025			\$ (1,400)	\$ 12,625
Police - Operations	2130 \$ 97,023	\$ 17,535		\$ (3,719)	\$ 110,839
Police - Special Operations	2135 \$ 14,813			\$ (3,977)	\$ 10,836
Police - Support Services	2140 \$ 592,821			\$ (23,815)	\$ 569,006
Police - Code Enforcement	2150 \$ 10,030			\$ 200	\$ 10,230
Fire - Operations	2200 \$ 215,400			\$ 27,000	\$ 242,400
Public Works - Facilities	1930 \$ 184,168			\$ 19,800	\$ 203,968
Public Works - Fleet	1940 \$ 233,069				\$ 233,069
Public Works - Administration	4100 \$ 203,199			\$ (59,800)	\$ 143,399
Public Works - Roads & ROW	4110 \$ 509,041	\$ 167,000		\$ (20,000)	\$ 656,041
P&R - Administration	7200 \$ 185,169			\$ 21,870	\$ 207,039
P&R - Athletics	7210 \$ 2,083			\$ 51	\$ 2,134
P&R - Athletics Partnerships	7220 \$ 21,970				\$ 21,970
P&R - Parks & Grounds	7230 \$ 2,299,693	\$ 5,771	\$ 703,000	\$ 195,555	\$ 3,204,019
P&R - Programs	7240 \$ 278,225			\$ (22,956)	\$ 255,269
P&R - Seniors	7250 \$ 269,552			\$ 142,480	\$ 412,032
P&R - Community Events	7400 \$ 20,000	\$ 58,018		\$ (10,000)	\$ 68,018
General Fund Expenditures	18,577,900	\$ 265,061	\$ 712,108	\$ -	\$ 19,555,069
Budgeted Approp to (from) Fund Balance	\$ 1,499	\$ -	\$ -	\$ -	\$ 1,499



CONSENT AGENDA ITEM 302

CITY COMMISSION AGENDA | NOVEMBER 18, 2019 | REGULAR MEETING

TITLE

Award of RFP 07-19KM Landscape Maintenance Services

SUMMARY

The City issued RFP 07-19KM requesting proposals for landscape maintenance services for the entire City. These service bids have been broken into seven (7) packages. The RFP was issued on October 4, 2019 and responses were due back to the City by October 23, 2019. Six companies responded and the bid amounts are listed below.

The bid tabulation for base maintenance cost of each package is outlined below and attached to this item.

Company:			<i>JHL Land Management LLC</i>	<i>Dawnalee Corporation</i>	<i>Nature's Care</i>	<i>Brightview Landscape Services</i>	<i>Caligreen Landscaping</i>	<i>Yellowstone Landscape</i>
Pkg #	Description	Budget FY 2020	Annual	Annual	Annual	Annual	Annual	Annual
1	City of Winter Springs Municipal Facilities	\$ 88,050	\$ 232,000	No bid	\$ 172,884	\$ 67,620	\$ 51,120	\$ 89,040
2	SR 434, Medians, Ponds, and R.O.W.'s	\$ 152,940	\$ 124,600	\$ 154,560	\$ 224,340	\$ 215,676	No bid	\$ 161,880
3	City Parks	\$ 91,759	\$ 215,225	\$ 128,264	\$ 240,312	\$ 321,300	\$ 48,720	\$ 141,960
4	Cross Seminole Trail (within city limits)	\$ 24,600	\$ 105,000	\$ 43,140	\$ 62,964	\$ 53,760	No bid	\$ 36,960
5	Tuskawilla Lighting and Beautification District, Oak Forest Assessment District, and Tuskawilla Road (South of SR 434)	\$ 118,800	\$ 107,000	No bid	\$ 206,664	\$ 121,800	No bid	\$ 164,880
6	Blumberg Boulevard, North Tuskawilla Road (North of SR 434), and Market Square	\$ 46,200	\$ 113,225	\$ 52,350	\$ 69,048	\$ 86,904	No bid	\$ 41,700
7	Additional ROW and Ponds	\$ 207,240	No bid	\$ 178,600	\$ 320,344	\$ 405,960	No bid	No bid

The selection committee met on November 4, 2019 in a public meeting to discuss a recommendation to award the bid for each package. The ranking and price for each package are outlined below (price and quality was the basis of selection). The City expects a higher level of service and a reduction in cost of over \$16,000 based on the FY20 budgeted amounts for the services.

Bid Recommendation:

- Package #1- City of Winter Springs Municipal Facilities
 - Caligreen – \$51,120
- Package #2- S.R. 434, Medians, Ponds, and R.O.W.'s
 - Dawnalee – \$154,560
- Package #3- City Parks
 - Dawnalee – \$128,264
- Package #4- Cross Seminole Trail (within city limits)
 - Yellowstone – \$36,960
- Package #5- Tuskawilla Lighting and Beautification District, Oak Forest Assessment District, and Tuskawilla Road (South of SR 434)
 - Brightview – \$121,800
- Package #6- Blumberg Boulevard, North Tuskawilla Road (North of SR 434), and Market Square
 - Yellowstone – \$41,700
- Package #7- Additional ROW and Ponds
 - Dawnalee – \$178,600

RECOMMENDATION

Staff recommends the City Commission award RFP 07-19KM for the landscape and maintenance of city's property to; Caligreen (package #1), Dawnalee (package #2), Dawnalee (package #3), Yellowstone (package #4), Brightview (package #5), Yellowstone (package #6) and Dawnalee (package #7). Additionally, authorizing the City Manager and City Attorney to negotiate, prepare and execute any and all applicable contract documents consistent with this agenda.



CITY OF WINTER SPRINGS

REQUEST FOR PROPOSAL

LANDSCAPE MAINTENANCE SERVICES

RFP 07-19 KM
October 2019

I. RFP Objectives and Submission Requirements

- 1) Bid Proposals are hereby solicited by the City of Winter Springs, Florida for Monthly Landscape Maintenance Services for City properties to include the following packages:

<u>Package Number:</u>	<u>Description:</u>
1	City of Winter Springs Municipal Facilities
2	S.R. 434, Medians, Ponds, and R.O.W.'s
3	City Parks
4	Cross Seminole Trail (within city limits)
5	Tusawilla Lighting and Beautification District, Oak Forest Assessment District, and Tuskawilla Road (South of SR 434)
6	Blumberg Boulevard, North Tuskawilla Road (North of SR 434), and Market Square

- 2) **Sealed Proposals must be received by **October 23, 2019 at 10:00AM** at the City of Winter Springs, City Hall, 1126 East S.R. 434, Winter Springs, FL 32708.**

The Bidding Documents may be downloaded in PDF format from the City's website at the following link:

http://www.winterspringsfl.org/EN/web/gov/bids_purchasing.htm

- 3) Proposal must include all labor, material and equipment to provide Landscaping Services to the City of Winter Springs. Individual packages (6), locations, and/or areas are specified in scopes of work attached.

All questions regarding the bid should be directed to Kevin Maddox, Landscape Manager, at 407-327-8957 or by email to rmaddox@winterspringsfl.org.

II. Submitting your Proposal- Instructions to Respondents

1) Questions

A. Respondents are required to submit questions, in writing, to Kevin Maddox at RMaddox@winterspringsfl.org. All questions must be submitted prior to October 14, 2019. On October 14, 2019, an addendum to the RFP will be posted with answers to the questions that have been submitted. Respondents are highly encouraged to submit any questions they may have regarding the scope, geographical boundaries, frequency of services, or any other details needing clarification.

2) Complete a Proposal Form for each package

A. Complete a **Proposal Form** for each package you are responding to. Proposal Forms can be found under the scope or work sections for each package.

B. Each Proposal Form needs to be completed in its entirety and may not be altered or changed. Oral proposals or modifications will not be considered.

C. In cases of discrepancy between the numeric and written cost on the Proposal Form, the written cost will be used.

D. In Unit Price Sections, the Respondent must furnish a Unit Price for all items, regardless of the quantity.

E. The Proposal must be signed by the person or persons legally authorized to bind the Respondent to a Contract of this nature.

3) Documents Required for Proposal Submission

A. Company or Personal background information

i. This section should include how long the business has been in operation, how many employees, relevant experience, etc.

ii. Provide additional information and advantages of your firm/team/individual capacity.

iii. Provide a description of how the operation will be supervised and what quality controls will be in place to complete the service to a high level of expectation.

iv. Provide the principal point of contact(s) with whom the City will be working with.

a. This individual's ability to lead a team and provide a high level of customer satisfaction will be heavily considered when awarding a package.

B. A completed Proposal Form for each package the Respondent is interested in responding to

- C. Drug Free Workplace Form
- D. Non Collusion Affidavit
- E. Certificate of Insurance
- F. Hold Harmless Agreement
- G. References- At least three professional references
- H. Completed Checklist of required documents

4) Format of Proposal Submission

- A. All proposal forms and required documents must be enclosed in a sealed opaque envelope or box. The envelope or box must have a clear label on the front with the following information:
 - i. Project Name
 - ii. Respondent’s name and address
 - iii. “Proposal Enclosed” notated clearly and conspicuously on the package.
- B. Submit three (3) copies of the completed Proposal Form for each of the packages you are responding to.
- C. Proposals shall be delivered to:

Winter Springs City Hall
 Attention: Kevin Maddox
 1126 East SR 434
 Winter Springs, FL 32708

prior to October 23, 2019 at 10:00AM. Proposals received after this time will be automatically rejected and returned unopened to the person or business submitting the Proposal.

5) Modification and Withdrawal of Proposal

- A. Proposals may not be modified after submittal.
- B. Respondents may withdraw Proposals at any time prior to October 23, 2019 at 10:00AM. Withdrawal requests shall be made in writing and must be received by the City prior to October 23, 2019 at 10:00AM. Properly withdrawn Proposals will be returned unopened to the person or business submitting the Proposal.

III. Calendar of Events

Request for Proposals Advertised	October 4, 2019
Technical Questions Due to the City (written)	October 13, 2019 @ 11:59 PM
Responses to Questions Due from the City	October 14, 2019
Proposals Due to the City	October 23, 2019 @ 10:00 AM
Commission Approval of Qualified Vendor	October 28, 2019
Contract Negotiations	October 29- November 1
Effective Date of Landscaping Services	The week of November 4, 2019

IV. City Evaluation and Selection of Proposal

1) Basis of Award

- A. The City has the right to reject any or all Proposals.
- B. Except in cases where the City exercises the right to reject all Proposals, the Contract will be awarded, to the most responsive Proposal, by the City, as soon as practicable after reviewing the Proposals.
- C. The most responsive Proposal is one who has submitted the best overall Proposal regarding price, inclusivity, references, similar work experience, and familiarity of scope for the services listed in the proposal packages.
- D. To be responsive, a Proposal must be submitted on the forms provided as part of the Proposal Documents and shall include all items required by the Proposal Form.

2) Required Qualifications of Respondent

- A. To be judged responsive, the Respondent shall meet the following standards:
 - i. Experience in Landscape Maintenance Services. This should include maintaining commercial and/or large residential landscaping and may also include experience with landscape architecture/design.
 - ii. The capability to perform all of the services, as outlined in the Scope of Service, for each proposed package, at the cost and timeframe proposed.
 - iii. Has a familiarity with ISA standards, Florida grades and standards for nursery plants (Florida Fancy), drought tolerant plantings, EPD and SFWMD shoreline planting regulations and maintenance requirements
 - iv. Ability to maintain all records in accordance with local, State, and Federal Public Records Retention Requirements.

V. Definitions and Expectations for Maintenance Contract

1) The definitions below describe the City's expectation for maintenance. These definitions are applicable to all packages; unless the package description states otherwise. Unless otherwise noted; costs for all services listed shall be considered part of the monthly maintenance and shall be included in the cost for monthly maintenance at each site.

A. Mowing/Turf Care

- i. Mowing of all grassed areas shall be no less than once every seven (7) days in the heavy growing season and shall be no less than bi-weekly, or as instructed by the City's Representative, during the dormant growing season. Growing seasons are dictated by the weather and therefore may change per the City's Representative, but otherwise shall be:
 - a. Heavy Growing Season - March 15 through October 15
 - b. Dormant Growing Season - October 16 through March 14
- ii. Prior to mowing and trimming any turf and bed areas; paper, bottles, cans and all other debris (as well as misplaced dirt or sand) must be removed from areas immediately bordering site (ex: sidewalks and curb lines) and actual site locations. Areas are to look clean and neat and free of debris at all times.
- iii. At no time shall more than one-third (1/3) of the leaf surface be removed in one mowing in any turf area unless specifically authorized in writing by the City of Winter Springs.
- iv. Turf care activities shall be scheduled during the normal work week (M-F 7:30am to Dusk unless directed otherwise) as a general rule and to allow for access to water plant facilities. Should field conditions occur that require a modification to the normal service schedule, Contractor must give the City 24 hours' notice and receive approval prior to a service schedule modification.
- v. Specific Turf Care
 - a. St. Augustine
 - i. Shall be in accordance with the University of Florida Cooperative Extension Services Calendar for St. Augustine sod care, culture, and good horticultural practice as shown in Publication ENH 5. St. Augustine grassed areas will be mowed to a height of 4.5" inches on average, depending upon established grass needs, by finish mower or a groom mower.
 - b. Bahia Grass
 - i. Shall be in accordance with the University of Florida Cooperative Extension Services Calendar for Bahia Grass sod care, culture, and good

horticultural practice as shown in Publication ENH 6. Bahia grassed areas will be mowed to a height of 3" inches on average, depending upon established grass needs, by finish mower or a groom mower.

c. Cutting of Native Grasses

- i. Contractor is to cut Native Grasses to no more than 50% of their length.
- ii. Contractor is to cut native grasses in late winter to early spring; just prior to new shoot growth.

B. Remove Grass Clippings and debris

- i. All debris (grass clippings) created by the mowing process is to be removed by mechanical means from all adjacent and contiguous surfaces following all landscaping activities.
- ii. Any clipping, trimming debris will be removed from site as work is completed, or at the end of each day that work is performed. Lawn clippings may be left on the turf areas so long as no readily visible clumps remain on the grass surface after mowing. Otherwise large clumps of clippings will be collected and disposed of by Contractor. In case of fungal disease outbreaks, all clipping will be collected and properly disposed of until disease is undetectable. No debris bags shall be left on site more than 6 hours.

C. Pruning/Trimming Shrubs, hedges, and ornamentals

- i. Pruning of plants shall be performed as directed to remove dead wood harboring insects and disease and to promote maximum health and growth. The finding of insects or disease shall be reported immediately to the City so as to limit losses. Aesthetic pruning shall consist of removal of dead or broken branches. Pruning shall be performed to balance infiltration light to enhance new growth.
- ii. Selective pruning shall be performed as directed to remove dead wood or moss. Trees shall be trimmed to maintain the required Department of Transportation clearance of 14' over the roadway. Suckers at the base of trees and branches hanging low into the median so as to impede a lawn mower shall be removed as regular maintenance; buck horning is not permitted unless requested by the City.
- iii. Ligustrums and shrubbery shall not accumulate more than 2" of growth before being trimmed.
- iv. All plants shall be maintained to a well-shaped appearance according to each species' natural growth habit unless requested otherwise by the owner's representative. Flowering shrubs shall be pruned in the proper season to allow full flowering potential for the following flower season. Grouped

plantings shall be allowed to form masses appropriate to the species.

- v. Small leafed shrubs, such as Pittosporum, Azaleas and Indian hawthorn, etc., are to be kept trimmed in a tight, neat appearance, with removal of partial new growth after no more than four inches of new growth appears.
 - vi. Larger leafed shrubs, such as viburnum, may attain new growth reaching from 2" to 4" before removal. At no times are shrubs to display a disorderly appearance.
 - a. Ornamentals, such as crinum lilies, are to be trimmed aggressively during the rainy season to be kept neat and fungus free. This may be as frequent as every other week.
 - b. Sago palms are to be trimmed a minimum of three times a year, or more often, as directed, depending on growth and health. Azaleas are to be trimmed at regular intervals as described above with the exception of the months of October thru March when no trimming should be done to achieve maximum flowering.
 - c. Wax myrtles are to be trimmed aggressively in order to maintain a neat, compact habitat.
 - d. At no time is an herbicide to be used to rid plants of sucker growth. Instead, hand pulling or aggressive trimming routine is to be established.
 - e. All ornamentals that produce any dead fronds (i.e., coontie, sage, aztec grass, holly fem, etc.) are to be systematically checked and cleaned with special attention to early spring cleanup.
 - vii. Dead plant material shall be removed by the Contractor immediately during the normal service visit and a report filed with the City detailing the location of removal and species removed.
- D. Weedeater Trimming
- i. Areas inaccessible to mowing equipment shall be kept neat and trimmed as directed. Trimming of grass and weeds around any fixed objects (walls, light posts, light fixtures, equipment boxes, pond structures, sign posts and trees) will be done through chemical control within a limit of six inches (6") maximum or trimmer so as not to inflict damage of any kind to structure, equipment or tree.
- E. **Mulching- This should not be included in base maintenance price; costs for these services are established on the proposal form for each package.**
- i. Mulching is to be performed between November 1 and December 25 each year to keep planted areas neat and freshly

maintained. Mulch depth to be a minimum total depth of three (3) inches and placed, not dumped, as well as kept from around the immediate base of shrubs. Mulch type to be chosen by the City.

- ii. Beds should be cleared of leaves and other debris prior to adding new mulch. The intent of doing this will be to prevent unnecessary height growth of the beds.

F. Edging

- i. Edging of all walks, curbs, edging of pavements, and grass invasion shall be done weekly during the heavy growing season and bi-weekly for the remainder of the year.
- ii. All grass and dirt to be blown off onto grass areas only. No debris shall be blown onto hard surfaces or into shrub or flower beds.
- iii. Schedule for edging of soft surfaces such as turf, bed borders, and ground cover shall be performed bi-weekly or more as directed.

G. Weeding

- i. Weeding of all plant bed areas is to be as often as necessary to conform to the shrub trimming schedule, to control weed population and maintain healthy plants.
- ii. Remove weeds, vines and "voluntary" seedlings from planting beds. Weed control in landscaped areas will be accomplished by hand weeding and/or application of round-up and a pre-emergent herbicide if needed.
- iii. All weeds in sidewalks or pavement areas (including curbing) shall be chemically controlled or removed by hand.
- iv. The sod-free rings around trees are to be kept in weed-free condition, and shall be maintained at a diameter determined by the City.
- v. All mulch areas or plant beds shall be continuously maintained free of weeds or grasses.
- vi. All turf areas shall be maintained in a weed free condition. Any area that becomes infested with weeds or other undesirable grasses must be treated and or replaced at the cost of the Contractor.

H. Pruning/Tree Trimming (less than 13')

- i. All trees are to be trimmed as often as necessary to meet public safety requirements and comply with ISA and ANSI Industry Standards for tree care. Trimming of established trees shall be to a minimum of eight (8) foot and a maximum of thirteen (13) foot under canopy and pruned just outside the branch collar by the Service Provider.

- ii. Any trees greater than 13' should not be included in base maintenance price; costs for these services are established on the proposal form for each package.
 - iii. New or young trees are to be pruned with an ideal under canopy of six (6) feet or to a suitable and healthy height for each tree.
 - iv. Approved traffic (M.U.T.C.D.) warning devices shall be used when necessary to provide safety to persons and vehicular traffic within any areas undergoing pruning. Work will be scheduled after consulting with the City.
 - v. Dead palm fronds shall be removed as they occur from all palms. Seeds pods shall be removed on an as directed basis from all palms. Trimming of palm fronds shall be conducted with a hand saw. Only dead fronds shall be removed. Palms shall not be trimmed above 9 o'clock and 3 o'clock.
- I. Remove Spanish Moss
- i. Remove all low hanging Spanish Moss in ornamental trees and shrubs.
 - ii. Spanish Moss that is 8' or lower on any tree or ornamental shall be removed when other scheduled tasks are completed at the same frequency.
- J. **Annuals and/or Plant Replacements- This should not be included in base maintenance price; costs for these services are established on the proposal form for each package.**
- i. The Contractor shall be responsible for replacing any plant materials that die or become damaged to the point that the plant grade is less than Florida Number 1 as a result of neglect or damage caused by the maintenance operation.
 - ii. Replacement material shall be identical to plant species, quality and specifications of the materials at the time the loss occurs.
- K. **Insect and Disease Control This should not be included in base maintenance price; costs for these services are established on the proposal form for each package.**
- i. The Contractor shall establish, in conjunction with the City, a preventive program to insure proper care of turf and ornamentals.
 - ii. The Contractor warrants turf against infestation and disease and will replace same if deemed to be below accepted industry standards (IFAS) by the City.
 - iii. Application times for herbicide and pesticide applications shall be completed by licensed, trained individuals.
 - iv. Plants will be treated chemically as required to effectively control insect infestation and disease as environmental, horticultural and weather conditions permit. The Contractor is

responsible for any damaged areas due to disease or insect infestation.

L. Chemical Maintenance- Fertilizer and Herbicide This should not be included in base maintenance price; costs for these services are established on the proposal form for each package.

- i. Fertilization and insecticide treatments shall be provided as directed to maintain the health and appearance of all turf and plant material.
- ii. Soil amendments, fertilizer, nutrients, pesticides, fungicides, pre-emergent, post-emergent, and any other chemicals deemed proper, beneficial or required to maintain the turf and plant material by the Contractor shall be included in the chemical program monthly maintenance fee.
- iii. Monthly reports may be requested by the City. The reports should outline all treatment provided for the month and any deficits observed.
- iv. Timely and prompt treatment is to be performed on all areas detected with problems and areas at risk. A 7-10-day follow-up appointment is to be set with the City to ensure eradication of disease or pest problems. Subsequent visits, if necessary, are to be scheduled until the problems no longer exist.

M. Irrigation Inspection and Repair- This should not be included in base maintenance price; costs for these services are established on the proposal form for each package.

- i. Complete irrigation inspections shall be performed one (1) time per month at minimum.
- ii. Details of the inspection shall be recorded on a log sheet (to be submitted with the monthly billing) and consist of the following:
 - a. Turning on each zone and inspecting each head for the proper coverage, including straightening, adjusting the output of water, adjusting spray pattern and unclogging any heads.
 - b. Repairing broken heads and lateral lines, as necessary.
 - c. Checking the irrigation controller(s) for proper operation and programming. If there are battery controllers on the site, check each for battery life and replace at 75% depletion.
 - d. Checking all zone valves for proper open and closure, making sure to inspect for leaking from the mainline.
 - e. Checking water source for leaking and visual inspection of backflow device, if present.
 - f. Visually inspect turf, planters and trees in irrigated areas for signs of drought stress and effect adjustments and/or repairs to remedy the issue.

- iii. The Contractor shall submit a detailed report, at the time of billing of each monthly service, consisting of the clock and location, each zone by number, and any repairs or work performed during that service. All parts used will be itemized on the bill with a maximum of \$ 50.00 billed for repairs without VERBAL approval during the regular monthly scheduled maintenance visit.
 - a. If there is an additional cost for repairs beyond the maximum of \$50.00, the City must be given a verbal report of the repair and costs involved before the work is to be performed. No payment will be made for heads or parts damaged by the Contractor.
- iv. Contractor is to immediately prepare an estimate to repair or replace damaged parts on the property within the areas specified in this agreement to meet original specifications with commercial quality irrigation parts. All work performed by Contractor to meet industry standards. All damaged irrigation heads shall be turned in each month along with the monthly billing in order to qualify for payment.
- v. Labor cost for these services is established on the proposal form for each project. Material costs shall be paid on the basis of approved wholesale documented cost plus 15% for overhead and profit.
- vi. Contractor is to immediately notify the City if a mainline leak is noticed. Should the Contractor need to shut down the mainline for any reason, the City must be contacted at: (407) 327-5962.

N. Other Scope as specifically directed by City- This should not be included in base maintenance price; costs for these services are established on the proposal form for each package.

- i. Service Provider is to prepare proposal for additional work as it is requested by the City prior to commencing with additional work. Prior written approval is required for all additional scope not listed on this document.

2) Contractual Information

- A. The work to be performed under this Contract consists of landscape maintenance services for the City of Winter Springs Municipal Facilities. Perform all work in accordance with the Contract Documents. Furnish all materials, equipment, tools, and labor which are reasonably and properly inferable and necessary for the proper completion of the work, whether specifically indicated in the Contract Documents or not. Cost for all services listed shall be considered part of the monthly maintenance and shall be included in the cost for monthly maintenance at each site.

- i. The Contractors shall be obligated at its expense, immediately or promptly to repair to the City's Representative's satisfaction, any damage to exterior plantings, or irrigation systems or any other property within the areas specified in this agreement. In the event the contractor has not repaired any such damage within reasonable time, as determined by the City's Representative, the City may repair such damage and deduct such cost from the next payment due to the Contractor. The Contractor shall be liable to the City for any such cost in excess of the amount deducted by the City.
- ii. The Contractor shall be obligated to immediately notify the City Representative verbally and follow in writing within twenty-four (24) hours after the event of any damage which the Contractor discovers, or should have discovered in the exercise of reasonable care, whether or not such damage was caused by the Contractor.
- iii. Prior to the commencement of work on this contract, an authorized representative of the Contractor and the Designated Representative of the City may perform a video condition survey of all exterior plantings at each of the designated areas of the City covered by this Agreement. The Contractor and the City shall jointly prepare and sign a written report of the condition survey which shall describe the condition and location of all unhealthy plants
- iv. During the 30-day period preceding the expiration of the term of this Agreement, or, in the event of an earlier termination a 30-day period following the termination, a final condition survey may be made jointly by the City Representative and the Contractor. This survey shall establish a punch list of plantings and material that do not meet the specifications and that must be replaced prior to the final completion of the contract. If the plantings and materials so identified are not replaced, an appropriate amount shall be withheld from the final payment.

VI. Scope of Service for Each Package

1) Package #1- City of Winter Springs Municipal Facilities

- A. Locations and property description
 - i. Vacant Public Works Admin Building- 110 N. Flamingo Ave
 - a. Grounds directly in front/side of building and the parking area adjacent to N. Fairfax Ave. and Seminole County Fire Station.
 - ii. City Hall- 1126 E. SR 434
 - a. Entire grounds including retention pond perimeter fence and grass and green space surrounding rear parking lot.
 - iii. Police Department- 300 N. Moss Road
 - a. Entire grounds (front and rear) including (2) two retention ponds and R.O.W.
 - iv. Public Works Compound- 150 N. Hartman Lane
 - a. Entire grounds including retention ponds, grassy areas surrounding parking lots and around all compound buildings.
 - v. Old Water Treatment Plant #1- 1 First Ct.
 - a. Entire vacant lot across from Public Works Admin. Bldg.
 - vi. Water Treatment Plant #2- 700 Sheoah Blvd.
 - a. Behind Highlands HOA Tennis Courts, All areas within fence.
 - vii. Water Treatment Plant #3- 110 W. Bahama Rd
 - a. All areas inside and outside fenced area including R.O.W.
 - viii. East Water Treatment Plant- 851 Northern Way
 - a. All areas inside and outside fence including R.O.W. to drainage ditch (North) at power easement.
 - ix. West Water Treatment Plant- 1000 W. State Road 434
 - a. All areas inside and outside fence including elevated pond embankment.
 - x. East Wastewater Plant- 1560 Winter Springs Blvd.
 - a. All areas inside fence including elevated pond embankment.
 - xi. West Wastewater Plant- 1000 W. State Road 434
 - a. All areas inside and just outside fence including elevated pond embankment.
 - xii. Oak Forest Wastewater Plant- 1001 Papaya Ln.
 - a. All areas inside and landscaped areas surrounding parking lot and roadway surrounding building.

- xiii. Lake Jessup Water Augmentation Plant, located behind Winter Springs Dog Park in Central Winds Park- 1000 Central Winds Park
 - a. All areas surrounding facility from open field to Lake Jessup.
- B. Required Services
 - i. All locations in this package
 - a. The below services are required weekly through the growing season (3/15-10/15) and bi-weekly through the dormant season (10/16-3/14)
 - i. Mow, Blow, Trim Hedges, Weedeater, Edge, Prune Trees, Remove Spanish Moss, Trash Removal, and other miscellaneous services as requested.

2) Package #2 – S.R. 434, City of Winter Springs Medians, Right of Ways (ROWs), and Ponds

A. Locations and property description

i. S.R. 434 Medians (S.R. 419 to S.R. 417)

- a. From the intersection at S.R. 17/92 to S.R. 417 overpass (including median just East of S.R. 417 overpass). S.R. 434 Village Walk (17/92 to S.R. 419) has irrigation to be maintained. Timers are located at the intersections of Moss Rd. and Belle Ave. at S.R. 434. Medians between Central Winds Blvd. and Tuskawilla Rd. has irrigation to be maintained. Battery operated timers are located in the medians. All irrigation on S.R. 434 in medians and R.O.W. is supplied with reclaimed water. Mulching and Fertilization to be performed for all plant bed areas.

ii. S.R. 434 Rights of Way (R.O.W.)

- a. Both sides of the roadway on S.R. 434 from Talmo St. to S.R. 417, (to roadway sign East of the overpass on the South side R.O.W.). Service area is from curb to minimum of 5' behind sidewalks and planter bed areas (where applicable and wider as necessary in some areas). Service to include gazebo areas located at Moss Rd. and Winter Springs Elementary School (S.R. 434 frontage). S. R. 434 Village Walk (17/92 to S.R. 419) has irrigation to be maintained. Timers are located at the intersections of Moss Rd. and Belle Ave. on S.R. 434. Mulching and Fertilization to be performed for all plant bed areas.

iii. F.D.O.T. Ponds

- a. Pond #1 - Located between the Seminole County Bus Yard (Consolidated Services Compound)
- b. Pond #2 – Located between Stone Gable Subdivision and Winding Hollow Subdivision. Irrigation is to be maintained along front fence – TBOS Timer – (2) Zones.
- c. Pond #3 – Located adjacent to Post Office (includes ponds in front and back). Irrigation is to be maintained along front fence – TBOS Timer – (2) Zones.
- d. Pond #4 – Located on the north side of S.R. 434 West of Tuscora Blvd. Mulching and Fertilization to be performed for all plant bed areas. Public Works Compound- 150 N. Hartman Lane

iv. Vistawilla Dr. Median

- a. Median located on Vistawilla Dr. adjacent to S.R. 434. The reclaimed water irrigation has irrigation to be maintained. Timers are located at the intersections of

Moss Rd. and Belle Ave. on S.R. 434. Mulching and Fertilization to be performed for all plant bed areas.

B. Required Services

i. All locations in this package

a. The below services are required weekly through the growing season (3/15-10/15) and bi-weekly through the dormant season (10/16-3/14)

i. Mow, Blow, Trim Hedges, Weedeater, Mulch (Semi-Annually), Edge, Weeding Beds, Prune Trees, Remove Spanish Moss, Trash Removal, Fertilization (As directed), Insect and Disease Control (As Required), Irrigation Inspection and Repair (Monthly/As Required) and other additional services as requested.

3) Package #3 – City Parks

A. Locations and property description

- i. Central Winds Park- 1000 Central Winds Park Dr
- ii. Bear Creek Nature Trail- 1555 Winter Springs Blvd
- iii. Winter Springs Dog Park- 900 Hicks Ave
- iv. Fruitwood Park- 601 Fruitwood Ave
- v. Moss Park- 314 Moss Rd
- vi. Oak Hollow Park- 1237 Winding Chase Blvd
- vii. Ranchlands Park- 191 E. Tradewinds Rd
- viii. Sam Smith Memorial Park- 1562 Winter Springs Blvd
- ix. Sunshine Park- 400 N. Edgemon Ave
- x. Torcaso Park- 104 N. Moss Rd
- xi. Trotwood Park- 1224 Trotwood Blvd
- xii. Winding Hollow Park- 305 Winding Hollow Blvd

B. Required Services

- i. For Central Winds Park (location i)
 - a. The below services are required weekly through the growing season (3/15-10/15) and bi-weekly through the dormant season (10/16-3/14)
 - i. Mow, Blow, Trim Hedges, Weedeater, Mulch (Semi-Annually), Edge, Weeding Beds, Prune Trees, Remove Spanish Moss, Trash Removal, Fertilization (As directed), Annual Flower Rotation (As Requested), Insect and Disease Control (As Required), Irrigation Inspection and Repair (Monthly/As Required) and other additional services as requested.
- ii. All other locations in this package (locations ii-xii)
 - b. The below services are required weekly through the growing season (3/15-10/15) and bi-weekly through the dormant season (10/16-3/14)
 - i. Mow, Blow, Trim Hedges, Weedeater, Mulch (Semi-Annually), Edge, Weeding Beds, Prune Trees, Remove Spanish Moss, Trash Removal, Fertilization (As directed), Insect and Disease Control (As Required), Irrigation Inspection and Repair (Monthly/As Required) and other additional services as requested.

4) Package #4 – Cross Seminole Trail and Bridges

A. Locations and property description

- i. S.R. 434 Bridge
 - a. S.R. 434 Cross Seminole Trail Overpass, located just east of Tuskawilla Road. No work is performed on the actual bridge itself. Beds under and around bridge are included in this section. Service areas have irrigation with timer being located on the South West side of S.R. 434 by the power boxes.
- ii. Cross Seminole Trail
 - b. Just south (approximately 30') of the south entrance onto the S.R. 434 Cross Seminole Trail Overpass Bridge, heading North and West along the trail to the Layer Elementary School entrance road (current end of the trail). Maintain each side of trail to project boundaries which is usually 2 to 8 passes with a 50" mower deck, but this varies in many areas and steps must be taken to groom all affected areas. Includes small medians at each Trail Head entrance.
- iii. Cross Seminole Trail (Creek) Bridge
 - a. Located between the Seminole County Bus Yard (Consolidated Services Compound) and Layer Elementary School. Keep vines from growing overhand railings and onto the bridge. Trim any/all overhanging tree limbs and foliage.

B. Required Services

- i. For the Cross Seminole Trail (location i)
 - a. The below services are required weekly through the growing season (3/15-10/15) and bi-weekly through the dormant season (10/16-3/14)
 - i. Mow, Blow, Trim Hedges, Weedeater, Mulch (Semi-Annually), Edge, Weeding Beds, Prune Trees, Remove Spanish Moss, Trash Removal, Fertilization (As directed), Annual Flower Rotation (As Requested), Insect and Disease Control (As required), Irrigation Inspection, and Irrigation Repair (monthly/as required) and other services as requested.
- ii. All other locations in this package(locations ii and iii)
 - a. The below services are required weekly through the growing season (3/15-10/15) and bi-weekly through the dormant season (10/16-3/14)
 - i. Mow, Edge, Trim Hedges, Weedeater, Edge, Trim Trees, Remove Spanish Moss, Trash Removal, and other services as requested.

5) Package #5 – Tuskawilla Rd, Tuskawilla Lighting and Beautification District, and the Oak Forest Assessment District

A. Locations and property description

i. Tuskawilla Rd. Rights of Way (R.O.W.)

- a. East - Tuskawilla Rd. from S.R. 434 south to Lord of Life Church, from south wall at Trotwood Blvd. to and including power easement as well as the right of way in front of the Arbor Glen subdivision. West - Tuskawilla Rd. south to Tuskawilla Trail (Including Berm just south of the Church of the New Covenant).

ii. Tuskawilla Rd. Medians

- a. Medians on Tuskawilla Rd. from S.R. 434 south to end of median cut at the Church of the New Covenant (800 Tuskawilla Rd.) Irrigation on the center medians is operated by multiple TBOS battery controllers.

iii. Tuskawilla Lighting and Beautification District (TLBD)

- a. Just south (approximately 30') of the south entrance onto the S.R. 434 Cross Seminole Trail Overpass Bridge, heading North and West along the trail to the Layer Elementary School entrance road (current end of the trail). Maintain each side of trail to project boundaries which is usually 2 to 8 passes with a 50" mower deck, but this varies in many areas and steps must be taken to groom all affected areas. Includes small medians at each Trail Head entrance.

iv. Oak Forest Entrances

- a. Forest Creek Dr. – 50' north and south of the sign wall on the west side of Tuskawilla Rd. and north and south sides of Forest Creek Dr. to Benchwood Ct. and Benchwood Dr.
- b. Trotwood Blvd. – 50' north and south of the sign wall on the west side of Tuskawilla Rd. and north and south sides of Trotwood Blvd. to N. Endeavor Dr. and S. Endeavor Dr. including center median.
- c. Winter Springs Blvd. – 50' north and south of the sign wall on the west side of Winter Springs Blvd. (south side to end of sign wall at 1067 Winter Springs Blvd., north side to 1054 Winter Springs Blvd. including inaccessible area at perimeter of pond) and (2) center medians. Irrigation on the center medians is operated by multiple TBOS battery controllers.

- d. Oak Forest Dr. – 50’ north and south of the sign wall on the west side of Tuskawilla Rd. and north and south sides of Oak Forest Dr. to Cherokee Ct. and Cherokee Dr.
 - v. Oak Forest Wall
 - a. The entire length of the Oak Forest wall alongside Tuskawilla Rd., directly along the wall where plants, shrubs, and vines are planted. Wall boundaries are from the Tuskawilla Office Park to New Covenant Church, not including the section of wall owned and maintained by Grande Reserve. Backside of wall not included. (Irrigation – spray heads are along entire length of the wall and bubbler heads on Oak Trees located between Trotwood and Tuskawilla Office Park, all included. Timers are located at entrances to Oak Forest at Winter Springs Blvd. and Trotwood Blvd. entrances. All four (4) entrances have irrigation on these timers.)
- B. Required Services
- i. For the Tuskawilla Rd. ROWs (location i)
 - a. The below services are required weekly through the growing season (4/01-12/01) and bi-weekly through the dormant season (12/02-3/31)
 - i. Mow, Weedeater Trimming, Edge Grass, Trim Trees, Remove Spanish Moss, Trash Removal and other services as requested.
 - ii. All other locations in this package(locations ii and v)
 - a. The below services are required weekly through the growing season (4/01-12/01) and bi-weekly through the dormant season (12/02-3/31)
 - i. Mow, Blow, Trim Hedges, Weedeater Trimming, Mulch (Semi-Annually), Edge Grass, Weeding Beds, Trim Trees, Remove Spanish Moss, Trash Removal, Fertilization (As Required/Annually), Insect and Disease Control (As Required), Irrigation Inspection and Repair (Monthly/As Required) and other services as requested.

6) Package #6- N. Tuskawilla Rd, Blumberg Blvd, and Market Square

A. Locations and property description

i. Blumberg Blvd. (Center Median Gardens and Monuments)

- a. Just south (approximately 30') of the south entrance onto the S.R. 434 Cross Seminole Trail Overpass Bridge, heading North and West along the trail to the Layer Elementary School entrance road (current end of the trail). Maintain each side of trail to project boundaries which is usually 2 to 8 passes with a 50" mower deck, but this varies in many areas and steps must be taken to groom all affected areas. Includes small medians at each Trail Head entrance.

ii. N. Tuskawilla Rd. (S.R. 434 to 100' North of Blumberg Blvd.)

- a. S.R. 434 Cross Seminole Trail Overpass, located just east of Tuskawilla Road. No work is performed on the actual bridge itself. Beds under and around bridge are included in this section. Service areas have irrigation with timer being located on the South West side of S.R. 434 by the power boxes.

iii. Market Square

- a. Located at the Northwest corner of S.R. 434 and N. Tuskawilla Rd., Market Square consists of the property in and around the fountain and hardscape areas immediately adjacent to the face of the building/business entrances in the Winter Springs Town Center.

b. Required Services

B. All locations in the package

- a. Mow, Blow, Trim Hedges, Weedeater, Mulch (Semi-Annually), Edge, Weeding Beds, Prune Trees, Remove Spanish Moss, Trash Removal, Fertilization (As directed), Annual Flower Rotation (As Requested), Insect and Disease Control (As Required), Irrigation Inspection and Repair (Monthly/As Required) and other additional services as requested

Proposal Form



PACKAGE # _____

Respondent Name (Company): _____

Name and Title of Person Completing Form: _____

PROPOSED COST

Base Maintenance	\$
Palm Trimming Greater than 13' OA (per tree)	\$
Crepe Trimming Greater than 13' OA (per tree)	\$
Irrigation Inspections	\$
Mulch- Supplied and Installed (per cubic yard)	\$
Fertilizer (per application)	\$
Integrated Pest Management (per application)	\$
PROPOSAL TOTAL	\$

PLANT, TREE, AND GROUND COVER INSTALLATION

Not to be included as part of proposal review criteria. Price to include all components of installation including staking, watering in, and one-year warranty.

Annuals (Cost plus %)	%
Ground cover (Cost plus %)	%
Shrubs (Cost plus %)	%
Palms (Cost plus %)	%
Canopy trees (Cost plus %)	%
Understory trees (Cost plus %)	%
Sod (Cost plus %)	%

Proposal Form continued on next page.

Proposal Form (Continued)



PACKAGE # _____

TREE REMOVAL AND STUMP GRINDING

Not to be included as part of the proposal review criteria. Price to include back fill/sod if needed.

Tree removal 6"	\$
Tree removal 12"	\$
Tree removal 18"	\$
Tree removal 24"	\$
Tree removal 36"	\$

IRRIGATION REPAIR

Not to be included as part of proposal review criteria unless otherwise noted.

Wholesale price of materials plus proposed percentage	%
Irrigation Technician Hourly Rate	\$

Signature of person completing form: _____

SECTION 00700 – DRUG FREE WORKPLACE FORM

The undersigned proposer, in accordance with Florida Statute 287.087 hereby certifies that _____ does:

(Name of Business)

1. Publish a statement notifying employees that the unlawful manufacture, distribution, dispensing, possession or use of a controlled substance is prohibited in the workplace and specifying the actions that will be taken against employees for violations of such prohibition.
2. Inform employees about the dangers of drug abuse in the workplace, the business's policy of maintaining a drug-free workplace, any available drug counseling, rehabilitation, and employee assistance programs, and the penalties that may be imposed upon employees for drug abuse violations.
3. Give each employee engaged in providing the commodities or contractual services that are under contract a copy of the Drug-Free statement.
4. Notify the employees that as a condition of working on the commodities or contractual services that are under contract, employee will abide by the terms of the statement and will notify the employer of any conviction of, or plea of guilty or nolo contendere to, any violation of Chapter 893 or of any controlled substance law of the United States or any state, for a violation occurring in the workplace no later than five (5) days after such conviction.
5. Impose a sanction on, or require the satisfactory participation in a drug abuse assistance or rehabilitation program if such is available in the employee's community, by any employee who is so convicted.
6. Make a good faith effort to continue to maintain a drug-free workplace through implementation of this section.

As the person authorized to sign the statement, I certify that this business complies fully with the above requirements.

(Authorized signature)

(Date)

(Print/type name as signed above)

****THIS FORM MUST BE COMPLETED AND RETURNED WITH YOUR SUBMITTAL.**

NON-COLLUSION AFFIDAVIT OF PRIME RESPONDENT

STATE OF _____)

COUNTY OF _____)

_____, being duly sworn, deposes and says that:

(1) He/she is _____ of _____,
Title Firm/Company

the respondent that has submitted the attached response.

(2) He/she is fully informed respecting the preparation and contents of the attached solicitation and of all pertinent circumstances respecting such solicitation.

(3) Such solicitation is genuine and is not a collusive or sham solicitation.

(4) Neither the said respondent nor any of its officers, partners, owners, agent representatives, employees or parties in interest including this affiant, has in any way, colluded, conspired, or agreed, directly or indirectly, with any other respondent, firm or person, to submit a collusive or sham response in connection with the Agreement for which the attached response has been submitted or to refrain from proposing in connection with such Agreement, or has in any manner, directly or indirectly, sought by Agreement or collusion or communication or conference with any other responder, firm or person to fix the price or prices in the attached solicitation or of any other respondent, or to fix any overhead, profit or cost element of the proposed price or the proposed price of any other responder, or to secure through any collusion, conspiracy, connivance or unlawful Agreement any advantage against the City of Winter Springs, Florida, or any person interested in the proposed Agreement.

(5) The price or prices quoted in the attached response are fair and proper and are not tainted by any collusion, conspiracy, or unlawful Agreement on the part of the proposer or any of its agents, representatives, owners, employees, or parties of interest, including affiant.

(Signed)

(Title)

STATE OF FLORIDA

COUNTY OF SEMINOLE

The foregoing instrument was acknowledged before me this _____ by _____, who is personally known to me or who has produced _____ as identification and who did (did not) take an oath.

_____ (Signature of Notary Public)

_____ (Name of Notary Typed, Printed or Stamped)

Notary Public

_____ (Commission Number)

****THIS FORM MUST BE COMPLETED AND RETURNED WITH YOUR SUBMITTAL.**

SECTION 00900 – INSURANCE REQUIREMENTS FORM

Insurance Type	Required Limits
<input checked="" type="checkbox"/> Worker’s Compensation	Statutory Limits of Florida Statutes, Chapter 440 and all Federal Government Statutory Limits
<input checked="" type="checkbox"/> Employer’s Liability	\$1,000,000 each accident, single limit per occurrence
<input checked="" type="checkbox"/> Commercial General Liability (Occurrence Form) patterned after the current ISO form	\$1,000,000 single limit per occurrence \$3,000,000 aggregate for Bodily Injury Liability & Property Damage Liability. This shall include Premises and Operations; Independent Contractors; Products & Completed Operations & Contractual Liability.
<input checked="" type="checkbox"/> Indemnification	To the maximum extent permitted by Florida law, the Contractor/Vendor/Consultant shall indemnify and hold harmless City of Winter Springs, its officers and employees from any and all liabilities, damages, losses and costs, including, but not limited to, reasonable attorneys’ fees and paralegals’ fees, to the extent caused by the negligence, recklessness, or intentional wrongful conduct of the Contractor/Vendor/Consultant or anyone employed or utilized by the Contractor/Vendor/Consultant in the performance of the Agreement. This indemnification obligation shall not be construed to negate, abridge or reduce any other rights or remedies which otherwise may be available to an indemnified party or person described in this paragraph. This section does not pertain to any incident arising from the sole negligence of the City of Winter Springs.
<input checked="" type="checkbox"/> Automobile Liability	\$1,000,000 each person; Bodily Injury & Property Damage, Owned/Non-owned/Hired; Automobile Included.
<input type="checkbox"/> Other	

Vendor shall ensure that all subcontractors comply with the same insurance requirements that he/she is required to meet. The same Vendor shall provide the City with certificates of insurance meeting the required insurance provisions.

The City of Winter Springs must be named as “**ADDITIONAL INSURED**” on the Insurance Certificate for Commercial General Liability where required.

The Certificate Holder shall be named as City of Winter Springs.

Thirty (30) days cancellation notice required.

The undersigned firm agrees to obtain, prior to award, if selected, insurance as stated above.

PROPOSER/BIDDER

AUTHORIZED SIGNATURE

OFFICER TITLE

DATE

****THIS FORM MUST BE COMPLETED AND RETURNED WITH YOUR SUBMITTAL.**



RFP 07-19 KM
Addendum 1

Clarification of Basis of Award

The City anticipates award to the Respondent who submits the Proposals judged by the City to be the most advantageous. The City anticipates awarding Agreements to the highest ranked Respondent, but reserves the right to award more or fewer Agreements if it is in the best interest of the City. The City reserves the right to assign work or task orders to various Respondents based on pricing submitted. The City reserves the right to pick and choose Respondent based on ranking. The City reserves the right to enter into the Agreements negotiations with the highest ranked Respondent(s). If the City and any of these Respondent(s) cannot negotiate a successful Agreement, the City may terminate such negotiation(s) and begin negotiation(s) with the next highest ranked Respondent(s). No Respondent shall have any rights against the City arising from such negotiations.

Clarification for Package #5 Tuskawilla Rd, Tuskawilla Lighting and Beautification District, and the Oak Forest Assessment District

1. Location iii Tuskawilla Lighting and Beautification District. Maintenance of this location includes Winter Springs Blvd, east of Tuskawilla Rd, and the North and South fountain entrances into Tuskawilla (at the intersection on Winter Springs Blvd. and Tuskawilla Rd). Disregard subsection (a).

Clarification for Package #6 N. Tuskawilla Rd, Blumberg Blvd, and Market Square

1. Location i Blumberg Blvd. Maintenance of this location is for the Center Median Gardens and Monuments on Blumberg Blvd. Disregard subsection (a).
2. Location ii N. Tuskawilla Rd . Maintenance of this location is for N. Tuskawilla Rd from SR 434 to 100' North of Blumberg Blvd. Disregard subsection (a).

Update to Calendar of Events

The calendar of events has been updated to reflect the cancellation of the October 28, 2019 Commission Meeting. Please see below.

Request for Proposals Advertised	October 4, 2019
Technical Questions Due to the City (written)	October 13, 2019 @ 11:59 PM
Responses to Questions Due from the City	October 14, 2019
Proposals Due to the City	October 23, 2019 @ 10:00 AM
Commission Approval of Qualified Vendor	November 18, 2019
Contract Negotiations	November 19- November 27
Effective Date of Landscaping Services	The week of December 1, 2019



RFP 07-19 KM
Addendum 2 (9 pages)

Maps for Central Winds Park

Please see the below map for Central Winds Park. Please notice that only the common areas are to be included in this proposal; the athletic fields are not part of this contract.



- | | | |
|-----------------|-------------------------------------|--|
| 1. Dog Park | 4. Amphitheater | 7. Central Winds Parkway & Orange Avenue |
| 2. Lower Fields | 5. Baseball and Soccer Parking Lots | 8. Upper Fields |
| 3. Passive Area | 6. Front Entrance | |

Contract Length

The length of the contract will be two-years with the possibility of three (3) one-year extensions.

Site Visits

Site visits for the packages are not planned. To view the areas and provide more information for proposal formulation, use of Google Earth or other satellite imaging software is suggested.

Turf Species Frequencies

Mowing should be 40-42x per year for all species of turf.

Minor irrigation repairs

Minor irrigation repairs are not included and all repairs over \$50 need to be ~~proposed~~ preapproved prior to repair.

Spanish Moss Removal

Spanish moss will be removed by the request of the City.

Fig Vines- Oak Forest Wall

The fig vines will be trimmed twice per month during the growing season and once per month during the dormant season.

Location elaboration

The senior center should be included in the Sunshine Park proposal.

The road coming off of SR 434 to the West Wastewater Treatment Facility is not included in the proposal. Below is the property area for this location.



Current Landscaping Contracts

We have forwarded your request for current landscaping contracts to our City Clerk as a public records request.

Additional Proposal Package

Package #7- Additional ROW and Ponds

A. Locations and Property Description

- i. N. Edgemon R.O.W.**
 - a. Eastside – 3rd St to Canal
 - b. Westside – Senior Center to VFW Driveway
 - c. Westside – From Shepard Rd. to S.R. 419

- ii. N. Edgemon Traffic Medians**
 - a. From SR434 to Shepard Road
- iii. Bombay R.O.W.**
 - a. Westside – From 1st St. lot south to chain link fence including open area next to fence
- iv. S. Edgemon R.O.W. at Duke Energy Easement**
 - a. R.O.W. both sides and around bollards
- v. S. Moss Road Islands**
- vi. Murphy Road Island**
- vii. S. Edgemon Island**
- viii. Lombardy Canal**
 - a. Both sides
- ix. S. Flamingo Canal**
 - a. Both sides – from S. Moss to S. Edgemon Ave.
- x. Burgos Easement**
 - a. Between 113 and 115 Burgos Rd. south to S. Flamingo canal
- xi. Burgos/Edgemon R.O.W.**
 - a. From canal north to side lot at 111 S. Edgemon Ave.
- xii. S. Moss R.O.W.**
 - a. East side from canal north to Hacienda Village entrance
 - b. East side from S. Mosswood Circle to Dolphin Road
 - c. West Side from 434 to Church property line
- xiii. Bayberry Ct. Island**
- xiv. Dogwood Ct. Island**
- xv. Lombardy/Burgos R.O.W.**
 - a. Area between 120 and 110 Lombardy Road south to Burgos Road
- xvi. Cedarwood Ct. Island**
- xvii. Cypress Ct. Island**
- xviii. S. Moss Bridge R.O.W.**
 - a. Four corners of bridge and west side R.O.W. from bridge to fence at back of Elderwood Street
- xix. Murphy Road R.O.W. at Duke Energy Easement**

- a. R.O.W. both sides and around bollards
- xx. S. Edgemon Bridge/ R.O.W.**
 - a. Four corners at bridge area and ROW on eastside of S. Edgemon from Panama Road north to lot line @ 727 S. Edgemon
- xxi. Murphy Road Bridge R.O.W.**
 - a. Four corners of bridge area
- xxii. Charles St. Island**
- xxiii. Sherry Ave R.O.W.**
 - a. Westside ROW from SR419 to San Rafael Street
- xxiv. Sherry Ave. Medians**
 - a. Traffic calming medians from SR434 to SR419
 - b. ROW from San Gabriel N to SR419
- xxv. Wade St. Medians**
 - a. Traffic calming medians from SR434 to SR419
- xxvi. Hayes Road R.O.W.**
 - a. Westside from SR434 to Ranchlands sign just S. of Sailfish
 - b. Eastside from corner of SR434 to property line at Pearl Road
- xxvii. Pearl Road Islands**
- xxviii. Hayes Road Bridge/R.O.W.**
 - a. Four corners of bridge area including field on southeast corner of Alton Road and Hayes Road
- xxix. S. Moss Road R.O.W. Swales**
 - a. Both sides of ROW one mower width behind trail
- xxx. Panama Road R.O.W. Swales**
 - a. Both sides of ROW one mower width behind trail
- xxxi. Hayes Road R.O.W. Swales**
 - a. Both sides of ROW one mower width behind trail
- xxxii. Fisher Road R.O.W. and Field**
 - a. Westside from Morton Lane south to phone box including drainage field
- xxxiii. Alton Road Bridge/R.O.W.**
 - a. Four corners of bridge area and ROW
- xxxiv. Shore Road Bridge/R.O.W.**
 - a. Eastside corners and ROW
- xxxv. Mockingbird Easement/R.O.W.**
 - a. Both sides property line to tree line
- xxxvi. Oak Island Road**
- xxxvii. Shore Road Culvert**
 - a. Four corners of culvert
- xxxviii. George Street R.O.W.**
 - a. Area south of ditch from Sherry Street to Wade Street including ditch inlets
- xxxix. N. Moss Road R.O.W.**
 - a. Eastside from SR434 to SR419

- b. Westside from SR434 to SR419
- xl. Highlands R.O.W.'s**
 - a. Sheoah Blvd. – (both sides 18' from edge of pavement) with continuous edging at pavement.
 - b. Shepard Road – (south ROW) beginning at end of Wildwood Subdivision wall and to N. Edgemon Ave and (north ROW) from 1006 (Dittmer) to N. Edgemon Ave. (both sides including field behind sidewalk at effluent disposal ponds)
 - c. Sheoah Circle – (both sides 11' from edge of pavement)
 - d. Third Street – (both sides from Sheoah Blvd. to house lots 13' from edge of pavement)
 - e. MacGregor Road – including Highland Village Ct. island
 - f. Miami Drive Islands (2)
 - g. Jeffrey Ct. island
 - h. Shepard Ct. island
 - i. Sheoah Circle Island
 - j. Kilt Ct.
 - k. Ryan Ct.
- xli. Dyson Bridge**
 - a. Four corners of bridge area
- xlii. Seneca Blvd. R.O.W.**
 - a. Eastside – from Winter Springs Blvd to house side lot/ both sides of sidewalk
 - b. Westside – from Winter Springs Blvd to Chelsea Woods entrance sign/ both sides of sidewalk
- xliii. Gary Hillary Drive R.O.W.**
- xliv. Winter Springs Blvd. R.O.W. (Limits of R.O.W. are from edge of to walls or fences)**
 - a. Northside – from Gary Hillary to wall for Tusca Oaks
 - b. Northside – from Northern Way to end of brick wall at 1630 Winter Springs Blvd
 - c. Northside – from Davenport Glen brick wall to property line 1553 Winter Springs Blvd
 - d. Southside – from Fox Glen entrance to Sam Smith Park driveway including perimeter of pond
 - e. Southside – from bridge to Greenbriar Lane
- xlv. Northern Way R.O.W.**
 - a. Westside – Winter Springs Blvd to Cheetah Trail then from water plant to well #4
 - b. Northside – drainage ROW near Tuscora Drive – from property line to property line
 - c. Eastside – near Woodchuck Ct – from Duke Energy easement to Winter Springs Blvd
- xlvi. Northern Way Bridges (3)**

- a. Four corners including ROW
- xlvi. Greenbriar Lane R.O.W.**
 - a. Westside – near Creekside Circle from chain link fence to brick wall
 - b. Westside – from brick wall at Bentley Green to brick wall at Greenbriar Subdivision including Field and pond
 - c. Eastside – near Braewick Street from power transformer to brick wall at Chestnut Ridge including retention swale
- xlvi. Winter Springs Blvd. Bridges (2)**
 - a. Bear Creek – Four corners including pond on northeast side and ROW to brick wall
 - b. Howell Creek – Four Corners including pond on southeast and ROW southwest to Country Club property.
- xlv. N. Tuskawilla R.O.W.**
 - a. Westside – from SR434 to wall at Tuskawilla Trace Subdivision
 - b. Eastside – from McDonald’s property line to St Johns Landing subdivision
- I. Sequoia Court Islands**
- li. Trotwood Blvd. R.O.W. Field**
 - a. ROW field next to property at 1165 Trotwood to 1143 Trotwood (west side)
 - b. Across street – along fence (eastside) and lift station 10E near field
- lii. Wagner’s Curve**
 - a. ROW and swale in front of Central Winds Park entrance at telephone house
- liii. Gary Hillary Dry Pond**
 - a. Dry pond South of the 7-11
- liv. Donut Lake/S. Edgemon Ave.**
 - a. Both sides S Edgemon ROW between houses to edge of lake
- lv. Donut Lake/Murphy Road**
 - a. Area between 627 Murphy Road and rear lot of 217 Cottonwood to edge of Lake
- lvi. Mt. Laurel Pond**
 - a. Perimeter of pond
- lvii. Freedom Lane Pond**
 - a. Berm sides and top and pond bottom when dry.
- lviii. Baltic Lane Pond**
 - a. Berm sides and top and pond bottom when dry.
- lix. Brooks Ct. Pond**
 - a. Berm sides and top and pond bottom when dry.
- lx. Venture Ct. Pond**
 - a. Berm sides and top and pond bottom when dry.
- lxi. Seneca Blvd. Pond**
 - a. Perimeter of pond including ROW
- lxii. Bear Springs Road**

- a. Between Publix and The Rize Apartments ROW from Blumberg north to high school
- b. East Side from Blumberg north to high school
- Ixiii. First Street R.O.W.**
 - a. Area across from fire station #26 south side from Moss Road to north Flamingo Ave.
- Ixiv. Panama Road R.O.W.**
 - a. Both sides from S. Moss Road to Edgemon Ave.
- Ixv. Sam Smith Park R.O.W.**
 - a. ROW directly in front of park.
- Ixvi. Papaya Power Easements**
 - a. Power Easements (front areas) on Papaya, one is near Night Owl and the other is near Turkey Hollow.
- Ixvii. Winter Springs – Oak Forest R.O.W.**
 - a. Near 1030 Winter Springs Blvd. at chain link fences (both sides of roads). Also on the east side, 1030 to Chokeycherry.
- Ixviii. Benchwood R.O.W.**
 - a. Chain-link fence areas on Benchwood (both sides) near Winter Springs Blvd.
- Ixix. Chokeycherry (A) R.O.W.**
 - a. Chain-link fence areas (both sides) near 1085 Chokeycherry.
- Ixx. Sequoia R.O.W.**
 - a. Chain-link fence areas (both areas) near 983 Sequoia.
- Ixxi. Chokeycherry (B) R.O.W.**
 - a. Chain-link fence areas (both sides) near Sapling.
- Ixxii. Shetland R.O.W.**
 - a. Northern Way (west side) to property line before first driveway near Dyson and Shetland.
- Ixxiii. Northern Way R.O.W./Tuscora**
 - a. ROW from property line at Tuscany Place to Tuscora on Northern Way (north side). Service area is from curb line to fence.
- Ixxiv. Cross Seminole Trail – Vistawilla**
 - a. Vistawilla and Cross Seminole Trail. Service area is the four corners of the trail excluding the island.
- Ixxv. Cross Seminole Trail – Tuscora**
 - a. Tuscora and Cross Seminole Trail. Service area is the four corners of the trail excluding the island.
- Ixxvi. Northern Way – Southern Loop R.O.W.**
 - a. ROW along golf course between 1220 and 1218 Northern Way. Service area is from curb to tree line next to fairway.
- Ixxvii. Greenbriar and Northern Way Easement**
 - a. Field at Northern Way and Greenbriar. Power line easement south of where Greenbriar ends at Northern Way.
- Ixxviii. Fisher Road Medians and R.O.W.**

- a. Medians and ROW the length of Fisher Road from Panama to just past Morton Lane near the entrance to Seville Chase. Area extends from property line to property line on both sides of the road in ROW.
- lxxxix. Cheoy Lee Circle R.O.W.**
 - a. ROW along Cheoy Lee Circle between 662 and 652 from curb line to 5' behind sidewalk.
- lxxx. Northern Way R.O.W. – Southern Bell R.O.W.**
 - a. Empty lot next to fire station. Curb line in approx. 25' and the length of the property along Northern Way.
- lxxx. Highlands Pond**
 - a. Behind Highlands clubhouse at Shepard Road. Pond and drainage easement and immediate surrounding area to water's edge.
- lxxxii. Sheoah Circle Easement**
 - a. Across from 898 Stirling Drive. Easement from road into woods to water's edge.
- lxxxiii. Shepard Road Easement**
 - a. East of 3350 SR419, adjacent to pond/fence from Shepard Road to SR419.
- lxxxiv. Bahama Berm**
 - a. Behind homes 709-727 Edgemon Ave., Enter Access gate off of Bahama Road
- lxxxv. Gator Pond**
 - a. Behind Homes 424-430 Hawthorn Circle, access through power easement off of Murphy Road
- lxxxvi. Murphy Pond**
 - a. Behind 608 Murphy Road, enter next to 608 Murphy Road Maintain around pond to water's edge
- lxxxvii. Murphy Lake**
 - a. Enter access path to Murphy lake directly across from Elderwood Street, maintain around most of lake to woods/property lines to water's edge, service area ends behind 301 Panama Circle.
- lxxxviii. Edgemon/Murphy ROW**
 - a. Intersection of Murphy Road and S. Edgemon Ave, maintain ROW easement along S. Edgemon and on Murphy Road.
- lxxxix. Oviedo Line at Winter Springs Blvd**
 - a. South side of Winter Springs Blvd at Seneca, small triangular field.
- xc. Boat Pond**
 - a. Behind homes 1784-1786 Seneca Blvd, maintain around two ponds to water's edge.
- xc. Lamoka Easement**
 - a. Behind homes 1760-1774 Seneca Blvd., access at 1760 Seneca Blvd.
- xcii. Donnas Pond**
 - a. Behind homes 1722-1732 Seneca Blvd., maintain drainage easement.

B. Required Services

- i. All locations in this package
 - a. The below services are required weekly through the growing season (3/15-10/15) and bi-weekly through the dormant season (10/16-3/14)
 - i. Mow, Blow, Trim Hedges, String Trim, Edge, Prune Trees, Remove Spanish Moss, Trash Removal, and other miscellaneous services as requested.

Package #	Description	Company		JHL Land Management LLC		Dawnalee Corporation		Nature's Care		Brightview Landscape Services		Caligreen Landscaping		Yellowstone Landscape	
		Monthly	Annual	Monthly	Annual	Monthly	Annual	Monthly	Annual	Monthly	Annual	Monthly	Annual	Monthly	Annual
1	City of Winter Springs Municipal Facilities	\$ 19,333	\$ 232,000	No bid	No bid	\$ 14,407	\$ 172,884	\$ 5,635	\$ 67,620	\$ 4,260	\$ 51,120	\$ 7,420	\$ 89,040		
2	S.R. 434, Medians, Ponds, and R.O.W.'s	\$ 10,383	\$ 124,600	\$ 12,880	\$ 154,560	\$ 18,695	\$ 224,340	\$ 17,973	\$ 215,676	No bid	No bid	\$ 13,490	\$ 161,880		
3	City Parks	\$ 17,935	\$ 215,225	\$ 10,689	\$ 128,264	\$ 20,026	\$ 240,312	\$ 26,775	\$ 321,300	\$ 4,060	\$ 48,720	\$ 11,830	\$ 141,960		
4	Cross Seminole Trail (within city limits)	\$ 8,750	\$ 105,000	\$ 3,595	\$ 43,140	\$ 5,247	\$ 62,964	\$ 4,480	\$ 53,760	No bid	No bid	\$ 3,080	\$ 36,960		
5	Tusawilla Lighting and Beautification District, Oak Forest Assessment District, and Tuskawilla Road (South of SR 434)	\$ 8,917	\$ 107,000	No bid	No bid	\$ 17,222	\$ 206,664	\$ 10,150	\$ 121,800	No bid	No bid	\$ 13,740	\$ 164,880		
6	Blumberg Boulevard, North Tuskawilla Road (North of SR 434), and Market Square	\$ 9,435	\$ 113,225	\$ 4,363	\$ 52,350	\$ 5,754	\$ 69,048	\$ 7,242	\$ 86,904	No bid	No bid	\$ 3,475	\$ 41,700		
7	Additional ROW and Ponds	No bid	No bid	\$ 14,883	\$ 178,600	\$ 26,695	\$ 320,344	\$ 33,830	\$ 405,960	No bid	No bid	No bid	No bid		



City of Winter Springs

Landscape Maintenance Services

RFP #07-19 KM

Proposal Due Date: October 23, 2019

Responses to “Request for Proposal (RFP) #07-19 KM, Landscape Maintenance Services” have been reviewed and evaluated by the City’s Advisory Selection Committee. The total scoring for each of Respondents was announced at the Advisory Selection Committee Meeting on Monday November 4th at 10 AM in the City Commission Chambers. The scoring totals (out of a maximum 300 points) and rankings are as follows:

Package #1

- Caligreen – 243
- Brightview – 240
- Yellowstone – 180
- JHL – 115
- Nature’s Care – 110

Package #2

- Dawnalee – 245
- JHL – 228
- Yellowstone – 215
- Brightview – 145
- Nature’s Care – 115

Package #3

- Dawnalee – 270
- Yellowstone – 225
- JHL – 163
- Brightview – 153
- Nature’s Care – 135
- Caligreen – 110

Package #4

- Yellowstone – 260
- Dawnalee – 235
- Brightview – 200
- JHL – 143
- Nature’s Care – 140

Package #5

- Brightview – 238
- JHL – 235
- Yellowstone – 180
- Nature’s Care – 130

Package #6

Yellowstone – 265

Dawnalee – 245

Brightview – 170

Nature's Care – 155

JHL – 130

Package #7

Dawnalee – 265

Brightview – 155

Nature's Care – 145

The rankings will be presented to the City Commission at the November 18th meeting.



CITY OF WINTER SPRINGS

REQUEST FOR PROPOSAL

LANDSCAPE MAINTENANCE SERVICES

RFP 07-19 KM
October 2019

U.S. LAWNS

Company Proposal Submission in reference to RFP 07-19KM

Established in 1986, U.S. Lawns is the largest and fastest-growing commercial landscape maintenance franchisor in the country. We now have over 250 U.S. Lawns locations in almost all 50 states, and we continue to expand to reach more clients. Our ability to have multiple locations within a short distance to Winter Springs approx. 10m provides us with a quick reaction time to all of City of Winter Springs needs.

We plan on providing a full time Supervisor Wic Novak to help with this endeavor to assure the job gets done correctly. Wic has over 30 years of landscape experience in multi million dollar companies he has also been in charge of such projects like Orlando Convention Center. Wic provides inspections on a bi weekly basis providing Quality Inspection Reports and recommendations for improvements or hazards to the client.

Point of Contacts will be Wic and the myself the Owner .

We hope to help the Winter Springs municipality with their Landscape Needs and look forward to hearing from you.



Respectfully,

Lou Silva

I. RFP Objectives and Submission Requirements

- 1) Bid Proposals are hereby solicited by the City of Winter Springs, Florida for Monthly Landscape Maintenance Services for City properties to include the following packages:

<u>Package Number:</u>	<u>Description:</u>
1	City of Winter Springs Municipal Facilities ✓
2	S.R. 434, Medians, Ponds, and R.O.W.'s
3	City Parks
4	Cross Seminole Trail (within city limits)
5	Tuskawilla Lighting and Beautification District, Oak Forest Assessment District, and Tuskawilla Road (South of SR 434)
6	Blumberg Boulevard, North Tuskawilla Road (North of SR 434), and Market Square

- 2) **Sealed Proposals must be received by October 23, 2019 at the City of Winter Springs, City Hall, 1126 East S.R. 434, Winter Springs, FL 32708.**

The Bidding Documents may be downloaded in PDF format from the City's website at the following link:

<http://www.winterspringsfl.org>

- 3) Proposal must include all labor, material and equipment to provide Landscaping Services to the City of Winter Springs. Individual packages (6), locations, and/or areas are specified in scopes of work attached.

All questions regarding the bid should be directed to Kevin Maddox, Landscape Manager, at 407-327-8957 or by email to kmaddox@winterspringsfl.org.

II. Submitting your Proposal- Instructions to Respondents

1) Questions

A. Respondents are required to submit questions, in writing, to Kevin Maddox at Kevin.Maddox@cityofwintersprings.com. All questions must be submitted prior to October 14, 2019. On October 14, 2019, an addendum to the RFP will be posted with answers to the questions that have been submitted. Respondents are highly encouraged to submit any questions they may have regarding the scope, geographical boundaries, frequency of services, or any other details needing clarification.

2) Complete a Proposal Form for each package

A. Complete a **Proposal Form** for each package you are responding to. Proposal Forms can be found under the scope or work sections for each package.

B. Each Proposal Form needs to be completed in its entirety and may not be altered or changed. Oral proposals or modifications will not be considered.

C. In cases of discrepancy between the numeric and written cost on the Proposal Form, the written cost will be used.

D. In Unit Price Sections, the Respondent must furnish a Unit Price for all items, regardless of the quantity.

E. The Proposal must be signed by the person or persons legally authorized to bind the Respondent to a Contract of this nature.

3) Documents Required for Proposal Submission

A. Company or Personal background information

i. This section should include how long the business has been in operation, how many employees, relevant experience, etc.

ii. Provide additional information and advantages of your firm/team/individual capacity.

iii. Provide a description of how the operation will be supervised and what quality controls will be in place to complete the service to a high level of expectation.

iv. Provide the principal point of contact(s) with whom the City will be working with.

a. This individual's ability to lead a team and provide a high level of customer satisfaction will be heavily considered when awarding a package.

B. A completed Proposal Form for each package the Respondent is interested in responding to

- C. Drug Free Workplace Form
- D. Non Collusion Affidavit
- E. Certificate of Insurance
- F. Hold Harmless Agreement
- G. References- At least three professional references
- H. Completed Checklist of required documents

4) Format of Proposal Submission

- A. All proposal forms and required documents must be enclosed in a sealed opaque envelope or box. The envelope or box must have a clear label on the front with the following information:
 - i. Project Name
 - ii. Respondent's name and address
 - iii. "Proposal Enclosed" notated clearly and conspicuously on the package.
- B. Submit three (3) copies of the completed Proposal Form for each of the packages you are responding to.
- C. Proposals shall be delivered to:

Winter Springs City Hall
 Attention: Kevin Maddox
 1126 East SR 434
 Winter Springs, FL 32708

prior to October 23, 2019 at 10:00AM. Proposals received after this time will be automatically rejected and returned unopened to the person or business submitting the Proposal.

5) Modification and Withdrawal of Proposal

- A. Proposals may not be modified after submittal.
- B. Respondents may withdraw Proposals at any time prior to October 23, 2019 at 10:00AM. Withdrawal requests shall be made in writing and must be received by the City prior to October 23, 2019 at 10:00AM. Properly withdrawn Proposals will be returned unopened to the person or business submitting the Proposal.

III. Calendar of Events

Request for Proposals Advertised	October 4, 2019
Technical Questions Due to the City (written)	October 13, 2019 @ 11:59 PM
Responses to Questions Due from the City	October 14, 2019
Proposals Due to the City	October 23, 2019 @ 10:00 AM
Commission Approval of Qualified Vendor	October 28, 2019
Contract Negotiations	October 29- November 1
Effective Date of Landscaping Services	The week of November 4, 2019

IV. City Evaluation and Selection of Proposal

1) Basis of Award

- A. The City has the right to reject any or all Proposals.
- B. Except in cases where the City exercises the right to reject all Proposals, the Contract will be awarded, to the most responsive Proposal, by the City, as soon as practicable after reviewing the Proposals.
- C. The most responsive Proposal is one who has submitted the best overall Proposal regarding price, inclusivity, references, similar work experience, and familiarity of scope for the services listed in the proposal packages.
- D. To be responsive, a Proposal must be submitted on the forms provided as part of the Proposal Documents and shall include all items required by the Proposal Form.

2) Required Qualifications of Respondent

- A. To be judged responsive, the Respondent shall meet the following standards:
 - i. Experience in Landscape Maintenance Services. This should include maintaining commercial and/or large residential landscaping and may also include experience with landscape architecture/design.
 - ii. The capability to perform all of the services, as outlined in the Scope of Service, for each proposed package, at the cost and timeframe proposed.
 - iii. Has a familiarity with ISA standards, Florida grades and standards for nursery plants (Florida Fancy), drought tolerant plantings, EPD and SFWMD shoreline planting regulations and maintenance requirements
 - iv. Ability to maintain all records in accordance with local, State, and Federal Public Records Retention Requirements.

V. Definitions and Expectations for Maintenance Contract

- 1) The definitions below describe the City's expectation for maintenance. These definitions are applicable to all packages; unless the package description states otherwise. Unless otherwise noted; costs for all services listed shall be considered part of the monthly maintenance and shall be included in the cost for monthly maintenance at each site.

A. Mowing/Turf Care

- i. Mowing of all grassed areas shall be no less than once every seven (7) days in the heavy growing season and shall be no less than bi-weekly, or as instructed by the City's Representative, during the dormant growing season. Growing seasons are dictated by the weather and therefore may change per the City's Representative, but otherwise shall be:
 - a. Heavy Growing Season - March 15 through October 15
 - b. Dormant Growing Season - October 16 through March 14
- ii. Prior to mowing and trimming any turf and bed areas; paper, bottles, cans and all other debris (as well as misplaced dirt or sand) must be removed from areas immediately bordering site (ex: sidewalks and curb lines) and actual site locations. Areas are to look clean and neat and free of debris at all times.
- iii. At no time shall more than one-third (1/3) of the leaf surface be removed in one mowing in any turf area unless specifically authorized in writing by the City of Winter Springs.
- iv. Turf care activities shall be scheduled during the normal work week (M-F 7:30am to Dusk unless directed otherwise) as a general rule and to allow for access to water plant facilities. Should field conditions occur that require a modification to the normal service schedule, Contractor must give the City 24 hours' notice and receive approval prior to a service schedule modification.
- v. Specific Turf Care
 - a. St. Augustine
 - i. Shall be in accordance with the University of Florida Cooperative Extension Services Calendar for St. Augustine sod care, culture, and good horticultural practice as shown in Publication ENH 5. St. Augustine grassed areas will be mowed to a height of 4.5" inches on average, depending upon established grass needs, by finish mower or a groom mower.
 - b. Bahia Grass
 - i. Shall be in accordance with the University of Florida Cooperative Extension Services Calendar for Bahia Grass sod care, culture, and good

horticultural practice as shown in Publication ENH 6. Bahia grassed areas will be mowed to a height of 3" inches on average, depending upon established grass needs, by finish mower or a groom mower.

c. Cutting of Native Grasses

- i. Contractor is to cut Native Grasses to no more than 50% of their length.
- ii. Contractor is to cut native grasses in late winter to early spring; just prior to new shoot growth.

B. Remove Grass Clippings and debris

- i. All debris (grass clippings) created by the mowing process is to be removed by mechanical means from all adjacent and contiguous surfaces following all landscaping activities.
- ii. Any clipping, trimming debris will be removed from site as work is completed, or at the end of each day that work is performed. Lawn clippings may be left on the turf areas so long as no readily visible clumps remain on the grass surface after mowing. Otherwise large clumps of clippings will be collected and disposed of by Contractor. In case of fungal disease outbreaks, all clipping will be collected and properly disposed of until disease is undetectable. No debris bags shall be left on site more than 6 hours.

C. Pruning/Trimming Shrubs, hedges, and ornamentals

- i. Pruning of plants shall be performed as directed to remove dead wood harboring insects and disease and to promote maximum health and growth. The finding of insects or disease shall be reported immediately to the City so as to limit losses. Aesthetic pruning shall consist of removal of dead or broken branches. Pruning shall be performed to balance infiltration light to enhance new growth.
- ii. Selective pruning shall be performed as directed to remove dead wood or moss. Trees shall be trimmed to maintain the required Department of Transportation clearance of 14' over the roadway. Suckers at the base of trees and branches hanging low into the median so as to impede a lawn mower shall be removed as regular maintenance; buck horning is not permitted unless requested by the City.
- iii. Ligustrums and shrubbery shall not accumulate more than 2' of growth before being trimmed.
- iv. All plants shall be maintained to a well-shaped appearance according to each species' natural growth habit unless requested otherwise by the owner's representative. Flowering shrubs shall be pruned in the proper season to allow full flowering potential for the following flower season. Grouped

plantings shall be allowed to form masses appropriate to the species.

- v. Small leafed shrubs, such as Pittosporum, Azaleas and Indian hawthorn, etc., are to be kept trimmed in a tight, neat appearance, with removal of partial new growth after no more than four inches of new growth appears.
- vi. Larger leafed shrubs, such as viburnum, may attain new growth reaching from 2" to 4" before removal. At no times are shrubs to display a disorderly appearance.
 - a. Ornamentals, such as crinum lilies, are to be trimmed aggressively during the rainy season to be kept neat and fungus free. This may be as frequent as every other week.
 - b. Sago palms are to be trimmed a minimum of three times a year, or more often, as directed, depending on growth and health. Azaleas are to be trimmed at regular intervals as described above with the exception of the months of October thru March when no trimming should be done to achieve maximum flowering.
 - c. Wax myrtles are to be trimmed aggressively in order to maintain a neat, compact habitat.
 - d. At no time is an herbicide to be used to rid plants of sucker growth. Instead, hand pulling or aggressive trimming routine is to be established.
 - e. All ornamentals that produce any dead fronds (i.e., coontie, sage, aztec grass, holly fem, etc.) are to be systematically checked and cleaned with special attention to early spring cleanup.
- vii. Dead plant material shall be removed by the Contractor immediately during the normal service visit and a report filed with the City detailing the location of removal and species removed.

D. Weedeater Trimming

- i. Areas inaccessible to mowing equipment shall be kept neat and trimmed as directed. Trimming of grass and weeds around any fixed objects (walls, light posts, light fixtures, equipment boxes, pond structures, sign posts and trees) will be done through chemical control within a limit of six inches (6") maximum or trimmer so as not to inflict damage of any kind to structure, equipment or tree.

E. **Mulching- This should not be included in base maintenance price; costs for these services are established on the proposal form for each package.**

- i. Mulching is to be performed between November 1 and December 25 each year to keep planted areas neat and freshly

maintained. Mulch depth to be a minimum total depth of three (3) inches and placed, not dumped, as well, as kept from around the immediate base of shrubs. Mulch type to be chosen by the City.

- ii. Beds should be cleared of leaves and other debris prior to adding new mulch. The intent of doing this will be to prevent unnecessary height growth of the beds.

F. Edging

- i. Edging of all walks, curbs, edging of pavements, and grass invasion shall be done weekly during the heavy growing season and bi-weekly for the remainder of the year.
- ii. All grass and dirt to be blown off onto grass areas only. No debris shall be blown onto hard surfaces or into shrub or flower beds.
- iii. Schedule for edging of soft surfaces such as turf, bed borders, and ground cover shall be performed bi-weekly or more as directed.

G. Weeding

- i. Weeding of all plant bed areas is to be as often as necessary to conform to the shrub trimming schedule, to control weed population and maintain healthy plants.
- ii. Remove weeds, vines and "voluntary" seedlings from planting beds. Weed control in landscaped areas will be accomplished by hand weeding and/or application of round-up and a pre-emergent herbicide if needed.
- iii. All weeds in sidewalks or pavement areas (including curbing) shall be chemically controlled or removed by hand.
- iv. The sod-free rings around trees are to be kept in weed-free condition, and shall be maintained at a diameter determined by the City.
- v. All mulch areas or plant beds shall be continuously maintained free of weeds or grasses.
- vi. All turf areas shall be maintained in a weed free condition. Any area that becomes infested with weeds or other undesirable grasses must be treated and or replaced at the cost of the Contractor.

H. Pruning/Tree Trimming (less than 13')

- i. All trees are to be trimmed as often as necessary to meet public safety requirements and comply with ISA and ANSI Industry Standards for tree care. Trimming of established trees shall be to a minimum of eight (8) foot and a maximum of thirteen (13) foot under canopy and pruned just outside the branch collar by the Service Provider.

- ii. Any trees greater than 13' should not be included in base maintenance price; costs for these services are established on the proposal form for each package.
 - iii. New or young trees are to be pruned with an ideal under canopy of six (6) feet or to a suitable and healthy height for each tree.
 - iv. Approved traffic (M.U.T.C.D.) warning devices shall be used when necessary to provide safety to persons and vehicular traffic within any areas undergoing pruning. Work will be scheduled after consulting with the City.
 - v. Dead palm fronds shall be removed as they occur from all palms. Seeds pods shall be removed on an as directed basis from all palms. Trimming of palm fronds shall be conducted with a hand saw. Only dead fronds shall be removed. Palms shall not be trimmed above 9 o'clock and 3 o'clock.
- I. Remove Spanish Moss
- i. Remove all low hanging Spanish Moss in ornamental trees and shrubs.
 - ii. Spanish Moss that is 8' or lower on any tree or ornamental shall be removed when other scheduled tasks are completed at the same frequency.
- J. **Annuals and/or Plant Replacements- This should not be included in base maintenance price; costs for these services are established on the proposal form for each package.**
- i. The Contractor shall be responsible for replacing any plant materials that die or become damaged to the point that the plant grade is less than Florida Number 1 as a result of neglect or damage caused by the maintenance operation.
 - ii. Replacement material shall be identical to plant species; quality and specifications of the materials at the time the loss occurs.
- K. **Insect and Disease Control This should not be included in base maintenance price; costs for these services are established on the proposal form for each package.**
- i. The Contractor shall establish, in conjunction with the City, a preventive program to insure proper care of turf and ornamentals.
 - ii. The Contractor warrants turf against infestation and disease and will replace same if deemed to be below accepted industry standards (IFAS) by the City.
 - iii. Application times for herbicide and pesticide applications shall be completed by licensed, trained individuals.
 - iv. Plants will be treated chemically as required to effectively control insect infestation and disease as environmental, horticultural and weather conditions permit. The Contractor is

responsible for any damaged areas due to disease or insect infestation.

L. Chemical Maintenance- Fertilizer and Herbicide This should not be included in base maintenance price; costs for these services are established on the proposal form for each package.

- i. Fertilization and insecticide treatments shall be provided as directed to maintain the health and appearance of all turf and plant material.
- ii. Soil amendments, fertilizer, nutrients, pesticides, fungicides, pre-emergent, post-emergent, and any other chemicals deemed proper, beneficial or required to maintain the turf and plant material by the Contractor shall be included in the chemical program monthly maintenance fee.
- iii. Monthly reports may be requested by the City. The reports should outline all treatment provided for the month and any deficits observed.
- iv. Timely and prompt treatment is to be performed on all areas detected with problems and areas at risk. A 7-10-day follow-up appointment is to be set with the City to ensure eradication of disease or pest problems. Subsequent visits, if necessary, are to be scheduled until the problems no longer exist.

M. Irrigation Inspection and Repair- This should not be included in base maintenance price; costs for these services are established on the proposal form for each package.

- i. Complete irrigation inspections shall be performed one (1) time per month at minimum.
- ii. Details of the inspection shall be recorded on a log sheet (to be submitted with the monthly billing) and consist of the following:
 - a. Turning on each zone and inspecting each head for the proper coverage, including straightening, adjusting the output of water, adjusting spray pattern and unclogging any heads.
 - b. Repairing broken heads and lateral lines, as necessary.
 - c. Checking the irrigation controller(s) for proper operation and programming. If there are battery controllers on the site, check each for battery life and replace at 75% depletion.
 - d. Checking all zone valves for proper open and closure; making sure to inspect for leaking from the mainline.
 - e. Checking water source for leaking and visual inspection of backflow device, if present.
 - f. Visually inspect turf, planters and trees in irrigated areas for signs of drought stress and effect adjustments and/or repairs to remedy the issue.

- iii. The Contractor shall submit a detailed report, at the time of billing of each monthly service, consisting of the clock and location, each zone by number, and any repairs or work performed during that service. All parts used will be itemized on the bill with a maximum of \$ 50.00 billed for repairs without VERBAL approval during the regular monthly scheduled maintenance visit.
 - a. If there is an additional cost for repairs beyond the maximum of \$50.00, the City must be given a verbal report of the repair and costs involved before the work is to be performed. No payment will be made for heads or parts damaged by the Contractor.
- iv. Contractor is to immediately prepare an estimate to repair or replace damaged parts on the property within the areas specified in this agreement to meet original specifications with commercial quality irrigation parts. All work performed by Contractor to meet industry standards. All damaged irrigation heads shall be turned in each month along with the monthly billing in order to qualify for payment.
- v. Labor cost for these services is established on the proposal form for each project. Material costs shall be paid on the basis of approved wholesale documented cost plus 15% for overhead and profit.
- vi. Contractor is to immediately notify the City if a mainline leak is noticed. Should the Contractor need to shut down the mainline for any reason, the City must be contacted at: (407) 327-5962.

N. Other Scope as specifically directed by City- This should not be included in base maintenance price; costs for these services are established on the proposal form for each package.

- i. Service Provider is to prepare proposal for additional work as it is requested by the City prior to commencing with additional work. Prior written approval is required for all additional scope not listed on this document.

2) Contractual Information

- A. The work to be performed under this Contract consists of landscape maintenance services for the City of Winter Springs Municipal Facilities. Perform all work in accordance with the Contract Documents. Furnish all materials, equipment, tools, and labor which are reasonably and properly inferable and necessary for the proper completion of the work, whether specifically indicated in the Contract Documents or not. Cost for all services listed shall be considered part of the monthly maintenance and shall be included in the cost for monthly maintenance at each site.

- i. The Contractors shall be obligated at its expense, immediately or promptly to repair to the City's Representative's satisfaction, any damage to exterior plantings, or irrigation systems or any other property within the areas specified in this agreement. In the event the contractor has not repaired any such damage within reasonable time, as determined by the City's Representative, the City may repair such damage and deduct such cost from the next payment due to the Contractor. The Contractor shall be liable to the City for any such cost in excess of the amount deducted by the City.
- ii. The Contractor shall be obligated to immediately notify the City Representative verbally and follow in writing within twenty-four (24) hours after the event of any damage which the Contractor discovers, or should have discovered in the exercise of reasonable care, whether or not such damage was caused by the Contractor.
- iii. Prior to the commencement of work on this contract, an authorized representative of the Contractor and the Designated Representative of the City may perform a video condition survey of all exterior plantings at each of the designated areas of the City covered by this Agreement. The Contractor and the City shall jointly prepare and sign a written report of the condition survey which shall describe the condition and location of all unhealthy plants
- iv. During the 30-day period preceding the expiration of the term of this Agreement, or, in the event of an earlier termination a 30-day period following the termination, a final condition survey may be made jointly by the City Representative and the Contractor. This survey shall establish a punch list of plantings and material that do not meet the specifications and that must be replaced prior to the final completion of the contract. If the plantings and materials so identified are not replaced, an appropriate amount shall be withheld from the final payment.

VI. Scope of Service for Each Package

1) Package #1- City of Winter Springs Municipal Facilities

A. Locations and property description

- i. Vacant Public Works Admin Building- 110 N. Flamingo Ave
 - a. Grounds directly in front/side of building and the parking area adjacent to N. Fairfax Ave. and Seminole County Fire Station.
- ii. City Hall- 1126 E. SR 434
 - a. Entire grounds including retention pond perimeter fence and grass and green space surrounding rear parking lot.
- iii. Police Department- 300 N. Moss Road
 - a. Entire grounds (front and rear) including (2) two retention ponds and R.O.W.
- iv. Public Works Compound- 150 N. Hartman Lane
 - a. Entire grounds including retention ponds, grassy areas surrounding parking lots and around all compound buildings.
- v. Old Water Treatment Plant #1- 1 First Ct.
 - a. Entire vacant lot across from Public Works Admin. Bldg.
- vi. Water Treatment Plant #2- 700 Sheoah Blvd.
 - a. Behind Highlands HOA Tennis Courts, All areas within fence.
- vii. Water Treatment Plant #3- 110 W. Bahama Rd
 - a. All areas inside and outside fenced area including R.O.W.
- viii. East Water Treatment Plant- 851 Northern Way
 - a. All areas inside and outside fence including R.O.W. to drainage ditch (North) at power easement.
- ix. West Water Treatment Plant- 1000 W. State Road 434
 - a. All areas inside and outside fence including elevated pond embankment.
- x. East Wastewater Plant- 1560 Winter Springs Blvd.
 - a. All areas inside fence including elevated pond embankment.
- xi. West Wastewater Plant- 1000 W. State Road 434
 - a. All areas inside and just outside fence including elevated pond embankment.
- xii. Oak Forest Wastewater Plant- 1001 Papaya Ln.
 - a. All areas inside and landscaped areas surrounding parking lot and roadway surrounding building.

xiii. Lake Jessup Water Augmentation Plant, located behind Winter Springs Dog Park in Central Winds Park- 1000 Central Winds Park

a. All areas surrounding facility from open field to Lake Jessup.

B. Required Services

i. All locations in this package

a. The below services are required weekly through the growing season (3/15-10/15) and bi-weekly through the dormant season (10/16-3/14)

i. Mow, Blow, Trim Hedges, Weedeater, Edge Prune Trees, Remove Spanish Moss, Trash Removal, and other miscellaneous services as requested.

2) Package #2 – S.R. 434, City of Winter Springs Medians, Right of Ways (ROWs), and Ponds

A. Locations and property description

i. S.R. 434 Medians (S.R. 419 to S.R. 417)

- a. From the intersection at S.R. 17/92 to S.R. 417 overpass (including median just East of S.R. 417 overpass). S.R. 434 Village Walk (17/92 to S.R. 419) has irrigation to be maintained. Timers are located at the intersections of Moss Rd. and Belle Ave. at S.R. 434. Medians between Central Winds Blvd. and Tuskawilla Rd. has irrigation to be maintained. Battery operated timers are located in the medians. All irrigation on S.R. 434 in medians and R.O.W. is supplied with reclaimed water. Mulching and Fertilization to be performed for all plant bed areas.

ii. S.R. 434 Rights of Way (R.O.W.)

- a. Both sides of the roadway on S.R. 434 from Talmo St. to S.R. 417, (to roadway sign East of the overpass on the South side R.O.W.). Service area is from curb to minimum of 5' behind sidewalks and planter bed areas (where applicable and wider as necessary in some areas). Service to include gazebo areas located at Moss Rd. and Winter Springs Elementary School (S.R. 434 frontage). S. R. 434 Village Walk (17/92 to S.R. 419) has irrigation to be maintained. Timers are located at the intersections of Moss Rd. and Belle Ave. on S.R. 434. Mulching and Fertilization to be performed for all plant bed areas.

iii. F.D.O.T. Ponds

- a. Pond #1 - Located between the Seminole County Bus Yard (Consolidated Services Compound)
- b. Pond #2 – Located between Stone Gable Subdivision and Winding Hollow Subdivision. Irrigation is to be maintained along front fence – TBOS Timer – (2) Zones.
- c. Pond #3 – Located adjacent to Post Office (includes ponds in front and back). Irrigation is to be maintained along front fence – TBOS Timer – (2) Zones.
- d. Pond #4 – Located on the north side of S.R. 434 West of Tuscora Blvd. Mulching and Fertilization to be performed for all plant bed areas. Public Works Compound- 150 N. Hartman Lane

iv. Vistawilla Dr. Median

- a. Median located on Vistawilla Dr. adjacent to S.R. 434. The reclaimed water irrigation has irrigation to be maintained. Timers are located at the intersections of

Moss Rd. and Belle Ave. on S.R. 434. Mulching and Fertilization to be performed for all plant bed areas.

B. Required Services

i. All locations in this package

a. The below services are required weekly through the growing season (3/15-10/15) and bi-weekly through the dormant season (10/16-3/14)

i. Mow, Blow, Trim Hedges, Weedeater, Mulch (Semi-Annually), Edge, Weeding Beds, Prune Trees, Remove Spanish Moss, Trash Removal, Fertilization (As directed), Insect and Disease Control (As Required), Irrigation Inspection and Repair (Monthly/As Required) and other additional services as requested.

3) Package #3 – City Parks

A. Locations and property description

- i. Central Winds Park- 1000 Central Winds Park Dr
- ii. Bear Creek Nature Trail- 1555 Winter Springs Blvd
- iii. Winter Springs Dog Park- 900 Hicks Ave
- iv. Fruitwood Park- 601 Fruitwood Ave
- v. Moss Park- 314 Moss Rd
- vi. Oak Hollow Park- 1237 Winding Chase Blvd
- vii. Ranchlands Park- 191 E. Tradewinds Rd
- viii. Sam Smith Memorial Park- 1562 Winter Springs Blvd
- ix. Sunshine Park- 400 N. Edgemon Ave
- x. Torcaso Park- 104 N. Moss Rd
- xi. Trotwood Park- 1224 Trotwood Blvd
- xii. Winding Hollow Park- 305 Winding Hollow Blvd

B. Required Services

- i. For Central Winds Park (location i)
 - a. The below services are required weekly through the growing season (3/15-10/15) and bi-weekly through the dormant season (10/16-3/14)
 - i. Mow, Blow, Trim Hedges, Weedeater, Mulch (Semi-Annually), Edge, Weeding Beds, Prune Trees, Remove Spanish Moss, Trash Removal, Fertilization (As directed), Annual Flower Rotation (As Requested), Insect and Disease Control (As Required), Irrigation Inspection and Repair (Monthly/As Required) and other additional services as requested.
- ii. All other locations in this package (locations ii-xii)
 - b. The below services are required weekly through the growing season (3/15-10/15) and bi-weekly through the dormant season (10/16-3/14)
 - i. Mow, Blow, Trim Hedges, Weedeater, Mulch (Semi-Annually), Edge, Weeding Beds, Prune Trees, Remove Spanish Moss, Trash Removal, Fertilization (As directed), Insect and Disease Control (As Required), Irrigation Inspection and Repair (Monthly/As Required) and other additional services as requested.

4) Package #4 – Cross Seminole Trail and Bridges

A. Locations and property description

- i. S.R. 434 Bridge
 - a. S.R. 434 Cross Seminole Trail Overpass, located just east of Tuskawilla Road. No work is performed on the actual bridge itself. Beds under and around bridge are included in this section. Service areas have irrigation with timer being located on the South West side of S.R. 434 by the power boxes.
- ii. Cross Seminole Trail
 - b. Just south (approximately 30') of the south entrance onto the S.R. 434 Cross Seminole Trail Overpass Bridge, heading North and West along the trail to the Layer Elementary School entrance road (current end of the trail). Maintain each side of trail to project boundaries which is usually 2 to 8 passes with a 50" mower deck, but this varies in many areas and steps must be taken to groom all affected areas. Includes small medians at each Trail Head entrance.
- iii. Cross Seminole Trail (Creek) Bridge
 - a. Located between the Seminole County Bus Yard (Consolidated Services Compound) and Layer Elementary School. Keep vines from growing overhand railings and onto the bridge. Trim any/all overhanging tree limbs and foliage.

B. Required Services

- i. For the Cross Seminole Trail (location i)
 - a. The below services are required weekly through the growing season (3/15-10/15) and bi-weekly through the dormant season (10/16-3/14)
 - i. Mow, Blow, Trim Hedges, Weedeater, Mulch (Semi-Annually), Edge, Weeding Beds, Prune Trees, Remove Spanish Moss, Trash Removal, Fertilization (As directed), Annual Flower Rotation (As Requested), Insect and Disease Control (As required), Irrigation Inspection, and Irrigation Repair (monthly/as required) and other services as requested.
- ii. All other locations in this package(locations ii and iii)
 - a. The below services are required weekly through the growing season (3/15-10/15) and bi-weekly through the dormant season (10/16-3/14)
 - i. Mow, Edge, Trim Hedges, Weedeater, Edge, Trim Trees, Remove Spanish Moss, Trash Removal, and other services as requested.

5) Package #5 – Tuskawilla Rd. Tuskawilla Lighting and Beautification District and the Oak Forest Assessment District

A. Locations and property description

i. Tuskawilla Rd. Rights of Way (R.O.W.)

- a. East - Tuskawilla Rd. from S.R. 434 south to Lord of Life Church, from south wall at Trotwood Blvd. to and including power easement as well as the right of way in front of the Arbor Glen subdivision. West - Tuskawilla Rd. south to Tuskawilla Trail (Including Berm just south of the Church of the New Covenant).

ii. Tuskawilla Rd. Medians

- a. Medians on Tuskawilla Rd. from S.R. 434 south to end of median cut at the Church of the New Covenant (800 Tuskawilla Rd.) Irrigation on the center medians is operated by multiple TBOS battery controllers.

iii. Tuskawilla Lighting and Beautification District (TLBD)

- a. Just south (approximately 30') of the south entrance onto the S.R. 434 Cross Seminole Trail Overpass Bridge, heading North and West along the trail to the Layer Elementary School entrance road (current end of the trail). Maintain each side of trail to project boundaries which is usually 2 to 8 passes with a 50" mower deck, but this varies in many areas and steps must be taken to groom all affected areas. Includes small medians at each Trail Head entrance.

iv. Oak Forest Entrances

- a. Forest Creek Dr. – 50' north and south of the sign wall on the west side of Tuskawilla Rd. and north and south sides of Forest Creek Dr. to Benchwood Ct. and Benchwood Dr.
- b. Trotwood Blvd. – 50' north and south of the sign wall on the west side of Tuskawilla Rd. and north and south sides of Trotwood Blvd. to N. Endeavor Dr. and S. Endeavor Dr. including center median.
- c. Winter Springs Blvd. – 50' north and south of the sign wall on the west side of Winter Springs Blvd. (south side to end of sign wall at 1067 Winter Springs Blvd., north side to 1054 Winter Springs Blvd. including inaccessible area at perimeter of pond) and (2) center medians. Irrigation on the center medians is operated by multiple TBOS battery controllers.

d. Oak Forest Dr. – 50' north and south of the sign wall on the west side of Tuskawilla Rd. and north and south sides of Oak Forest Dr. to Cherokee Ct. and Cherokee Dr.

v. Oak Forest Wall

a. The entire length of the Oak Forest wall alongside Tuskawilla Rd., directly along the wall where plants, shrubs, and vines are planted. Wall boundaries are from the Tuskawilla Office Park to New Covenant Church, not including the section of wall owned and maintained by Grande Reserve. Backside of wall not included. (Irrigation – spray heads are along entire length of the wall and bubbler heads on Oak Trees located between Trotwood and Tuskawilla Office Park, all included. Timers are located at entrances to Oak Forest at Winter Springs Blvd. and Trotwood Blvd. entrances. All four (4) entrances have irrigation on these timers.)

B. Required Services

i. For the Tuskawilla Rd. ROWs (location i)

a. The below services are required weekly through the growing season (4/01-12/01) and bi-weekly through the dormant season (12/02-3/31)

i. Mow, Weedeater Trimming, Edge Grass, Trim Trees, Remove Spanish Moss, Trash Removal and other services as requested.

ii. All other locations in this package(locations ii and v)

a. The below services are required weekly through the growing season (4/01-12/01) and bi-weekly through the dormant season (12/02-3/31)

i. Mow, Blow, Trim Hedges, Weedeater Trimming, Mulch (Semi-Annually), Edge Grass, Weeding Beds, Trim Trees, Remove Spanish Moss, Trash Removal, Fertilization (As Required/Annually), Insect and Disease Control (As Required), Irrigation Inspection and Repair (Monthly/As Required) and other services as requested.

6) Package #6- N. Tuskawilla Rd, Blumberg Blvd, and Market Square

A. Locations and property description

i. Blumberg Blvd. (Center Median Gardens and Monuments)

- a. Just south (approximately 30') of the south entrance onto the S.R. 434 Cross Seminole Trail Overpass Bridge, heading North and West along the trail to the Layer Elementary School entrance road (current end of the trail). Maintain each side of trail to project boundaries which is usually 2 to 8 passes with a 50" mower deck, but this varies in many areas and steps must be taken to groom all affected areas. Includes small medians at each Trail Head entrance.

ii. N. Tuskawilla Rd. (S.R. 434 to 100' North of Blumberg Blvd.)

- a. S.R. 434 Cross Seminole Trail Overpass, located just east of Tuskawilla Road. No work is performed on the actual bridge itself. Beds under and around bridge are included in this section. Service areas have irrigation with timer being located on the South West side of S.R. 434 by the power boxes.

iii. Market Square

- a. Located at the Northwest corner of S.R. 434 and N. Tuskawilla Rd., Market Square consists of the property in and around the fountain and hardscape areas immediately adjacent to the face of the building/business entrances in the Winter Springs Town Center.

b. Required Services

B. All locations in the package

- a. Mow, Blow, Trim Hedges, Weedeater, Mulch (Semi-Annually), Edge, Weeding Beds, Prune Trees, Remove Spanish Moss, Trash Removal, Fertilization (As directed), Annual Flower Rotation (As Requested), Insect and Disease Control (As Required), Irrigation Inspection and Repair (Monthly/As Required) and other additional services as requested

Proposal Form



PACKAGE # 1

Respondent Name (Company): JHL Land Management LLC

Name and Title of Person Completing Form: Luis Silva owner

PROPOSED COST

Base Maintenance	\$	232,000/yr
Palm Trimming Greater than 13' OA (per tree)	\$	45.00
Crepe Trimming Greater than 13' OA (per tree)	\$	25.00
Irrigation Inspections	\$	75.00
Mulch- Supplied and Installed (per cubic yard)	\$	40.00
Fertilizer (per application)	\$	175.00
Integrated Pest Management (per application)	\$	250.00
PROPOSAL TOTAL	\$	232,610

PLANT, TREE, AND GROUND COVER INSTALLATION

Not to be included as part of proposal review criteria. Price to include all components of installation including staking, watering in, and one-year warranty.

Annuals (Cost plus %)	10	%
Ground cover (Cost plus %)	10	%
Shrubs (Cost plus %)	25	%
Palms (Cost plus %)	30	%
Canopy trees (Cost plus %)	30	%
Understory trees (Cost plus %)	20	%
Sod (Cost plus %)	25	%

Proposal Form



PACKAGE # 2

Respondent Name (Company): JHL Land Management LLC

Name and Title of Person Completing Form: Luis Silva owner

PROPOSED COST

Base Maintenance	\$	124,600
Palm Trimming Greater than 13' OA (per tree)	\$	45
Crepe Trimming Greater than 13' OA (per tree)	\$	25
Irrigation Inspections	\$	75
Mulch- Supplied and Installed (per cubic yard)	\$	40
Fertilizer (per application)	\$	175
Integrated Pest Management (per application)	\$	250
PROPOSAL TOTAL	\$	132,635

PLANT, TREE, AND GROUND COVER INSTALLATION

Not to be included as part of proposal review criteria. Price to include all components of installation including staking, watering in, and one-year warranty.

Annuals (Cost plus %)	10	%
Ground cover (Cost plus %)	10	%
Shrubs (Cost plus %)	25	%
Palms (Cost plus %)	30	%
Canopy trees (Cost plus %)	30	%
Understory trees (Cost plus %)	20	%
Sod (Cost plus %)	25	%

Proposal Form



PACKAGE # 3

Respondent Name (Company): JHL Land Management LLC

Name and Title of Person Completing Form: Luis Silva owner

PROPOSED COST

Base Maintenance	\$	215,225
Palm Trimming Greater than 13' OA (per tree)	\$	45.00
Crepe Trimming Greater than 13' OA (per tree)	\$	25.00
Irrigation Inspections	\$	75.00
Mulch- Supplied and Installed (per cubic yard)	\$	40.00
Fertilizer (per application)	\$	175.00
Integrated Pest Management (per application)	\$	250.00
PROPOSAL TOTAL	\$	215,610

PLANT, TREE, AND GROUND COVER INSTALLATION

Not to be included as part of proposal review criteria. Price to include all components of installation including staking, watering in, and one-year warranty.

Annuals (Cost plus %)	10	%
Ground cover (Cost plus %)	10	%
Shrubs (Cost plus %)	25	%
Palms (Cost plus %)	30	%
Canopy trees (Cost plus %)	30	%
Understory trees (Cost plus %)	20	%
Sod (Cost plus %)	25	%

Proposal Form



PACKAGE # 4

Respondent Name (Company): JHL Land Management LLC

Name and Title of Person Completing Form: Luis Silva owner

PROPOSED COST

Base Maintenance	\$	105.00/yr
Palm Trimming Greater than 13' OA (per tree)	\$	45
Crepe Trimming Greater than 13' OA (per tree)	\$	25
Irrigation Inspections	\$	75
Mulch- Supplied and Installed (per cubic yard)	\$	40
Fertilizer (per application)	\$	175
Integrated Pest Management (per application)	\$	250
PROPOSAL TOTAL	\$	105,610

PLANT, TREE, AND GROUND COVER INSTALLATION

Not to be included as part of proposal review criteria. Price to include all components of installation including staking, watering in, and one-year warranty.

Annuals (Cost plus %)		10	%
Ground cover (Cost plus %)		10	%
Shrubs (Cost plus %)		25	%
Palms (Cost plus %)		30	%
Canopy trees (Cost plus %)		30	%
Understory trees (Cost plus %)		20	%
Sod (Cost plus %)		25	%

Proposal Form



PACKAGE # 5

Respondent Name (Company): JHL Land Management LLC

Name and Title of Person Completing Form: Luis Silva owner

PROPOSED COST

Base Maintenance	\$	107,000/yr
Palm Trimming Greater than 13' OA (per tree)	\$	45
Crepe Trimming Greater than 13' OA (per tree)	\$	25
Irrigation Inspections	\$	75
Mulch- Supplied and Installed (per cubic yard)	\$	40
Fertilizer (per application)	\$	175
Integrated Pest Management (per application)	\$	250
PROPOSAL TOTAL	\$	107,610

PLANT, TREE, AND GROUND COVER INSTALLATION

Not to be included as part of proposal review criteria. Price to include all components of installation including staking, watering in, and one-year warranty.

Annuals (Cost plus %)	10	%
Ground cover (Cost plus %)	10	%
Shrubs (Cost plus %)	25	%
Palms (Cost plus %)	30	%
Canopy trees (Cost plus %)	30	%
Understory trees (Cost plus %)	20	%
Sod (Cost plus %)	25	%

Proposal Form



PACKAGE # 16

Respondent Name (Company): JHL Land Management LLC

Name and Title of Person Completing Form: Luis Silva owner

PROPOSED COST

Base Maintenance	\$	113,225
Palm Trimming Greater than 13' OA (per tree)	\$	45
Crepe Trimming Greater than 13' OA (per tree)	\$	25
Irrigation Inspections	\$	75
Mulch- Supplied and Installed (per cubic yard)	\$	40
Fertilizer (per application)	\$	175
Integrated Pest Management (per application)	\$	250
PROPOSAL TOTAL	\$	113,835

PLANT, TREE, AND GROUND COVER INSTALLATION

Not to be included as part of proposal review criteria. Price to include all components of installation including staking, watering in, and one-year warranty.

Annuals (Cost plus %)	10	%
Ground cover (Cost plus %)	10	%
Shrubs (Cost plus %)	25	%
Palms (Cost plus %)	30	%
Canopy trees (Cost plus %)	30	%
Understory trees (Cost plus %)	20	%
Sod (Cost plus %)	25	%

Proposal Form (Continued)



PACKAGE # _____

TREE REMOVAL AND STUMP GRINDING

Not to be included as part of the proposal review criteria. Price to include back fill/sod if needed.

Tree removal 6"	\$	350.00
Tree removal 12"	\$	475.00
Tree removal 18"	\$	585.00
Tree removal 24"	\$	625.00
Tree removal 36"	\$	750.00

IRRIGATION REPAIR

Not to be included as part of proposal review criteria unless otherwise noted.

Wholesale price of materials plus proposed percentage		25	%
Irrigation Technician Hourly Rate	\$	55.00	

Signature of person completing form: _____

SECTION 00700 – DRUG FREE WORKPLACE FORM

The undersigned proposer, in accordance with Florida Statute 287.087 hereby certifies that

JHL Land Management LLC does:

(Name of Business)

1. Publish a statement notifying employees that the unlawful manufacture, distribution, dispensing, possession or use of a controlled substance is prohibited in the workplace and specifying the actions that will be taken against employees for violations of such prohibition.
2. Inform employees about the dangers of drug abuse in the workplace, the business's policy of maintaining a drug-free workplace, any available drug counseling, rehabilitation, and employee assistance programs, and the penalties that may be imposed upon employees for drug abuse violations.
3. Give each employee engaged in providing the commodities or contractual services that are under contract a copy of the Drug-Free statement.
4. Notify the employees that as a condition of working on the commodities or contractual services that are under contract, employee will abide by the terms of the statement and will notify the employer of any conviction of, or plea of guilty or nolo contendere to, any violation of Chapter 893 or of any controlled substance law of the United States or any state, for a violation occurring in the workplace no later than five (5) days after such conviction.
5. Impose a sanction on, or require the satisfactory participation in a drug abuse assistance or rehabilitation program if such is available in the employee's community, by any employee who is so convicted.
6. Make a good faith effort to continue to maintain a drug-free workplace through implementation of this section.

As the person authorized to sign the statement, I certify that this business complies fully with the above requirements.

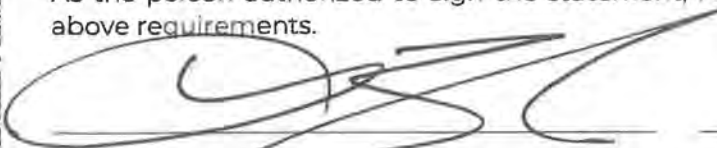

(Authorized signature)

10/20/19

(Date)

Luis Silva

(Print/type name as signed above)

****THIS FORM MUST BE COMPLETED AND RETURNED WITH YOUR SUBMITTAL.**

NON-COLLUSION AFFIDAVIT OF PRIME RESPONDENT

STATE OF Florida)

COUNTY OF Orange)

Luis Silva, being duly sworn, deposes and says that:

(1) He/she is owner of JHL Land Management LLC
Title Firm/Company

the respondent that has submitted the attached response.

(2) He/she is fully informed respecting the preparation and contents of the attached solicitation and of all pertinent circumstances respecting such solicitation.

(3) Such solicitation is genuine and is not a collusive or sham solicitation.

(4) Neither the said respondent nor any of its officers, partners, owners, agent representatives, employees or parties in interest including this affiant, has in any way, colluded, conspired, or agreed, directly or indirectly, with any other respondent, firm or person, to submit a collusive or sham response in connection with the Agreement for which the attached response has been submitted or to refrain from proposing in connection with such Agreement, or has in any manner, directly or indirectly, sought by Agreement or collusion or communication or conference with any other responder, firm or person to fix the price or prices in the attached solicitation or of any other respondent, or to fix any overhead, profit or cost element of the proposed price or the proposed price of any other responder, or to secure through any collusion, conspiracy, connivance or unlawful Agreement any advantage against the City of Winter Springs, Florida, or any person interested in the proposed Agreement.

(5) The price or prices quoted in the attached response are fair and proper and are not tainted by any collusion, conspiracy, or unlawful Agreement on the part of the proposer or any of its agents, representatives, owners, employees, or parties of interest, including affiant.

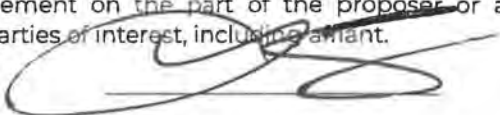

(Signed)

owner

(Title)

STATE OF FLORIDA

COUNTY OF SEMINOLE

The foregoing instrument was acknowledged before me this _____ by _____, who is personally known to me or who has produced _____ as identification and who did (did not) take an oath.

_____ (Signature of Notary Public)

_____ (Name of Notary Typed, Printed or Stamped)

Notary Public

_____ (Commission Number)

****THIS FORM MUST BE COMPLETED AND RETURNED WITH YOUR SUBMITTAL.**

Thirty (30) days cancellation notice required.

The undersigned firm agrees to obtain, prior to award, if selected, insurance as stated above.

JHL Land Management LLC
PROPOSER/BIDDER

AUTHORIZED SIGNATURE

owner
OFFICER TITLE

10/20/19
DATE

****THIS FORM MUST BE COMPLETED AND RETURNED WITH YOUR SUBMITTAL.**



RFP 07-19 KM
Addendum 1

City of Winter Springs Award

The City anticipates award to the Respondent who submits the Proposals judged by the City to be the most advantageous. The City anticipates awarding Agreements to the highest ranked Respondent, but reserves the right to award more or fewer Agreements if it is in the best interest of the City. The City reserves the right to assign work or task orders to various Respondents based on pricing submitted. The City reserves the right to pick and choose Respondent based on ranking. The City reserves the right to enter into the Agreements negotiations with the highest ranked Respondent(s). If the City and any of these Respondent(s) cannot negotiate a successful Agreement, the City may terminate such negotiation(s) and begin negotiation(s) with the next highest ranked Respondent(s). No Respondent shall have any rights against the City arising from such negotiations.

City of Winter Springs Award for Package #5 Tuskawilla Rd, Tuskawilla Lighting, and the Oak Forest Assessment District

1. Location iii Tuskawilla Lighting and Beautification District. Maintenance of this location includes Winter Springs Blvd, east of Tuskawilla Rd, and the North and South fountain entrances into Tuskawilla (at the intersection on Winter Springs Blvd. and Tuskawilla Rd). Disregard subsection (a).

City of Winter Springs Award for Package #6 N. Tuskawilla Rd, Blumberg Blvd, and Tuskawilla Rd

1. Location i Blumberg Blvd. Maintenance of this location is for the Center Median Gardens and Monuments on Blumberg Blvd. Disregard subsection (a).
2. Location ii N. Tuskawilla Rd . Maintenance of this location is for N. Tuskawilla Rd from SR 434 to 100' North of Blumberg Blvd. Disregard subsection (a).

City of Winter Springs Calendar of Events

The calendar of events has been updated to reflect the cancellation of the October 28, 2019 Commission Meeting. Please see below.

Request for Proposals Advertised	October 4, 2019
Technical Questions Due to the City (written)	October 13, 2019 @ 11:59 PM
Responses to Questions Due from the City	October 14, 2019
Proposals Due to the City	October 23, 2019 @ 10:00 AM
Commission Approval of Qualified Vendor	November 18, 2019
Contract Negotiations	November 19- November 27
Effective Date of Landscaping Services	The week of December 1, 2019

Proposal Form



PACKAGE # 1

Respondent Name (Company): Natures Care Orlando

Name and Title of Person Completing Form: Stefan Beaulieu, Vice President

PROPOSED COST

Base Maintenance	\$ 14,407.00 / 172,884.00
Palm Trimming Greater than 13' OA (per tree)	\$ 38.00
Crepe Trimming Greater than 13' OA (per tree)	\$ 18.00
Irrigation Inspections	\$ 361.00 / 4,332.00
Mulch- Supplied and Installed (per cubic yard)	\$ 39.50
Fertilizer (per application)	\$ 10,191.00 / 122,292.00
Integrated Pest Management (per application)	\$ 835.00 / 10,020.00
PROPOSAL TOTAL	\$ 25,889.50 / 309,623.50

PLANT, TREE, AND GROUND COVER INSTALLATION

Not to be included as part of proposal review criteria. Price to include all components of installation including staking, watering in, and one-year warranty.

Annuals (Cost plus %)	\$1.85 per flower installed	%
Ground cover (Cost plus %)	\$5.00 average cost installed	%
Shrubs (Cost plus %)	\$14.50 average cost installed	%
Palms (Cost plus %)	depending on size and species	%
Canopy trees (Cost plus %)	depending on size and species	%
Understory trees (Cost plus %)	depending on size and species	%
Sod (Cost plus %)	33	%

Proposal Form continued on next page.

Proposal Form (Continued)



PACKAGE # 1

TREE REMOVAL AND STUMP GRINDING

Not to be included as part of the proposal review criteria. Price to include back fill/sod if needed.

Tree removal 6"	\$ 300
Tree removal 12"	\$ 750
Tree removal 18"	\$ 1,400
Tree removal 24"	\$ 2,150
Tree removal 36"	\$ 3,100

IRRIGATION REPAIR

Not to be included as part of proposal review criteria unless otherwise noted.

Wholesale price of materials plus proposed percentage	40 %
Irrigation Technician Hourly Rate	\$ 55

Signature of person completing form: _____

SECTION 00700 – DRUG FREE WORKPLACE FORM

The undersigned proposer, in accordance with Florida Statute 287.087 hereby certifies that Natures Care Orlando does:

(Name of Business)

1. Publish a statement notifying employees that the unlawful manufacture, distribution, dispensing, possession or use of a controlled substance is prohibited in the workplace and specifying the actions that will be taken against employees for violations of such prohibition.
2. Inform employees about the dangers of drug abuse in the workplace, the business's policy of maintaining a drug-free workplace, any available drug counseling, rehabilitation, and employee assistance programs, and the penalties that may be imposed upon employees for drug abuse violations.
3. Give each employee engaged in providing the commodities or contractual services that are under contract a copy of the Drug-Free statement.
4. Notify the employees that as a condition of working on the commodities or contractual services that are under contract, employee will abide by the terms of the statement and will notify the employer of any conviction of, or plea of guilty or nolo contendere to, any violation of Chapter 893 or of any controlled substance law of the United States or any state, for a violation occurring in the workplace no later than five (5) days after such conviction.
5. Impose a sanction on, or require the satisfactory participation in a drug abuse assistance or rehabilitation program if such is available in the employee's community, by any employee who is so convicted.
6. Make a good faith effort to continue to maintain a drug-free workplace through implementation of this section.

As the person authorized to sign the statement, I certify that this business complies fully with the above requirements.



(Authorized signature)

October 23, 2019

(Date)

Stefan Beaulieu

(Print/type name as signed above)

****THIS FORM MUST BE COMPLETED AND RETURNED WITH YOUR SUBMITTAL.**

NON-COLLUSION AFFIDAVIT OF PRIME RESPONDENT

STATE OF Florida)

COUNTY OF Seminole)

Stefan Beaulieu, being duly sworn, deposes and says that:

(1) He/she is Vice President of Natures Care
Title Firm/Company

the respondent that has submitted the attached response.

- (2) He/she is fully informed respecting the preparation and contents of the attached solicitation and of all pertinent circumstances respecting such solicitation.
- (3) Such solicitation is genuine and is not a collusive or sham solicitation.
- (4) Neither the said respondent nor any of its officers, partners, owners, agent representatives, employees or parties in interest including this affiant, has in any way, colluded, conspired, or agreed, directly or indirectly, with any other respondent, firm or person, to submit a collusive or sham response in connection with the Agreement for which the attached response has been submitted or to refrain from proposing in connection with such Agreement, or has in any manner, directly or indirectly, sought by Agreement or collusion or communication or conference with any other responder, firm or person to fix the price or prices in the attached solicitation or of any other respondent, or to fix any overhead, profit or cost element of the proposed price or the proposed price of any other responder, or to secure through any collusion, conspiracy, connivance or unlawful Agreement any advantage against the City of Winter Springs, Florida, or any person interested in the proposed Agreement.
- (5) The price or prices quoted in the attached response are fair and proper and are not tainted by any collusion, conspiracy, or unlawful Agreement on the part of the proposer or any of its agents, representatives, owners, employees, or parties of interest, including affiant.

[Signature]
(Signed)

Vice President
(Title)

STATE OF FLORIDA

COUNTY OF SEMINOLE

The foregoing instrument was acknowledged before me this 10/23/19 by Stefan Beaulieu who is personally known to me or who has produced FL/DL as identification and who did (did not) take an oath.

[Signature] (Signature of Notary Public)

Walbert Soto (Name of Notary Typed, Printed or Stamped)

Notary Public GG42956 (Commission Number)

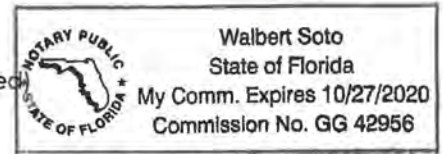

****THIS FORM MUST BE COMPLETED AND RETURNED WITH YOUR SUBMITTAL.**



CERTIFICATE OF LIABILITY INSURANCE

DATE (MM/DD/YYYY)
11/26/2018

THIS CERTIFICATE IS ISSUED AS A MATTER OF INFORMATION ONLY AND CONFERS NO RIGHTS UPON THE CERTIFICATE HOLDER. THIS CERTIFICATE DOES NOT AFFIRMATIVELY OR NEGATIVELY AMEND, EXTEND OR ALTER THE COVERAGE AFFORDED BY THE POLICIES BELOW. THIS CERTIFICATE OF INSURANCE DOES NOT CONSTITUTE A CONTRACT BETWEEN THE ISSUING INSURER(S), AUTHORIZED REPRESENTATIVE OR PRODUCER, AND THE CERTIFICATE HOLDER.

IMPORTANT: If the certificate holder is an ADDITIONAL INSURED, the policy(ies) must be endorsed. If SUBROGATION IS WAIVED, subject to the terms and conditions of the policy, certain policies may require an endorsement. A statement on this certificate does not confer rights to the certificate holder in lieu of such endorsement(s).

PRODUCER Closson Insurance Agency, LLC 1201 S. Orlando Avenue Suite 200 Winter Park FL 32789	CONTACT NAME: Lisa Albright	
	PHONE (A/C, No, Ext): (407) 898-2211 FAX (A/C, No): (407) 898-1850 E-MAIL ADDRESS: lalbright@clossoninsurance.com	
INSURED Nature's Care Orlando LLC 747 Commerce Circle Suite D Longwood FL 32750	INSURER(S) AFFORDING COVERAGE	NAIC #
	INSURER A: Southern-Owners Insurance Co	10190
	INSURER B: Owners Insurance Company	32700
	INSURER C: Associated Industries Ins Co.	23140
	INSURER D:	
	INSURER E:	

COVERAGES CERTIFICATE NUMBER: 11.26.18 REVISION NUMBER:

THIS IS TO CERTIFY THAT THE POLICIES OF INSURANCE LISTED BELOW HAVE BEEN ISSUED TO THE INSURED NAMED ABOVE FOR THE POLICY PERIOD INDICATED. NOTWITHSTANDING ANY REQUIREMENT, TERM OR CONDITION OF ANY CONTRACT OR OTHER DOCUMENT WITH RESPECT TO WHICH THIS CERTIFICATE MAY BE ISSUED OR MAY PERTAIN, THE INSURANCE AFFORDED BY THE POLICIES DESCRIBED HEREIN IS SUBJECT TO ALL THE TERMS, EXCLUSIONS AND CONDITIONS OF SUCH POLICIES. LIMITS SHOWN MAY HAVE BEEN REDUCED BY PAID CLAIMS.

INSR LTR	TYPE OF INSURANCE	ADDL SUBR INSD WVD	POLICY NUMBER	POLICY EFF (MM/DD/YYYY)	POLICY EXP (MM/DD/YYYY)	LIMITS
A	<input checked="" type="checkbox"/> COMMERCIAL GENERAL LIABILITY <input type="checkbox"/> CLAIMS-MADE <input checked="" type="checkbox"/> OCCUR		72020693	10/14/2018	10/14/2019	EACH OCCURRENCE \$ 1,000,000 DAMAGE TO RENTED PREMISES (Ea occurrence) \$ 300,000 MED EXP (Any one person) \$ 10,000 PERSONAL & ADV INJURY \$ 1,000,000 GENERAL AGGREGATE \$ 2,000,000 PRODUCTS - COMP/OP AGG \$ 2,000,000
B	<input checked="" type="checkbox"/> AUTOMOBILE LIABILITY <input type="checkbox"/> ANY AUTO ALL OWNED AUTOS <input type="checkbox"/> SCHEDULED AUTOS NON-OWNED AUTOS <input type="checkbox"/> HIRED AUTOS		4966660600	10/14/2018	10/14/2019	COMBINED SINGLE LIMIT (Ea accident) \$ 1,000,000 BODILY INJURY (Per person) \$ BODILY INJURY (Per accident) \$ PROPERTY DAMAGE (Per accident) \$ PIP-Basic \$ 10,000
A	<input checked="" type="checkbox"/> UMBRELLA LIAB <input checked="" type="checkbox"/> OCCUR <input type="checkbox"/> EXCESS LIAB <input type="checkbox"/> CLAIMS-MADE		5002069300	10/14/2018	10/14/2019	EACH OCCURRENCE \$ 1,000,000 AGGREGATE \$ 1,000,000
C	WORKERS COMPENSATION AND EMPLOYERS' LIABILITY ANY PROPRIETOR/PARTNER/EXECUTIVE OFFICER/MEMBER EXCLUDED? (Mandatory in NH) If yes, describe under DESCRIPTION OF OPERATIONS below	Y/N N/A	ANC1118829	12/3/2018	12/3/2019	<input checked="" type="checkbox"/> PER STATUTE <input type="checkbox"/> OTH-ER E.L. EACH ACCIDENT \$ 1,000,000 E.L. DISEASE - EA EMPLOYEE \$ 1,000,000 E.L. DISEASE - POLICY LIMIT \$ 1,000,000

DESCRIPTION OF OPERATIONS / LOCATIONS / VEHICLES (ACORD 101, Additional Remarks Schedule, may be attached if more space is required)
** FOR INFORMATIONAL PURPOSES ONLY **

CERTIFICATE HOLDER	CANCELLATION
** FOR INFORMATIONAL PURPOSES ONLY **	SHOULD ANY OF THE ABOVE DESCRIBED POLICIES BE CANCELLED BEFORE THE EXPIRATION DATE THEREOF, NOTICE WILL BE DELIVERED IN ACCORDANCE WITH THE POLICY PROVISIONS.
	AUTHORIZED REPRESENTATIVE Team Weis 3, Inc./LMA

Thirty (30) days cancellation notice required.

The undersigned firm agrees to obtain, prior to award, if selected, insurance as stated above.

Stefan Beaulieu / Natures Care Orlando

PROPOSER/BIDDER



AUTHORIZED SIGNATURE
Vice President

OFFICER TITLE
October 23, 2019

DATE

****THIS FORM MUST BE COMPLETED AND RETURNED WITH YOUR SUBMITTAL.**

Proposal Form



PACKAGE # 2

Respondent Name (Company): Natures Care Orlando

Name and Title of Person Completing Form: Stefan Beaulieu, Vice President

PROPOSED COST

Base Maintenance	\$ 18,695.00 / 224,340.00
Palm Trimming Greater than 13' OA (per tree)	\$ 38.00
Crepe Trimming Greater than 13' OA (per tree)	\$ 18.00
Irrigation Inspections	\$ 5,412.00 / 64,944.00
Mulch- Supplied and Installed (per cubic yard)	\$ 39.50
Fertilizer (per application)	\$ 6,700.00 / 80,400.00
Integrated Pest Management (per application)	\$ 3,232.00 / 38,784.00
PROPOSAL TOTAL	\$ 34,134.00 / 408,563.50

PLANT, TREE, AND GROUND COVER INSTALLATION

Not to be included as part of proposal review criteria. Price to include all components of installation including staking, watering in, and one-year warranty.

Annuals (Cost plus %)	\$1.85 per flower installed	%
Ground cover (Cost plus %)	\$5.00 average cost installed	%
Shrubs (Cost plus %)	\$14.50 average cost installed	%
Palms (Cost plus %)	depending on size and species	%
Canopy trees (Cost plus %)	depending on size and species	%
Understory trees (Cost plus %)	depending on size and species	%
Sod (Cost plus %)	33	%

Proposal Form continued on next page.

Proposal Form (Continued)



PACKAGE # 2

TREE REMOVAL AND STUMP GRINDING

Not to be included as part of the proposal review criteria. Price to include back fill/sod if needed.

Tree removal 6"	\$ 300
Tree removal 12"	\$ 750
Tree removal 18"	\$ 1,400
Tree removal 24"	\$ 2,150
Tree removal 36"	\$ 3,100

IRRIGATION REPAIR

Not to be included as part of proposal review criteria unless otherwise noted.

Wholesale price of materials plus proposed percentage	40	%
Irrigation Technician Hourly Rate	\$ 55	

Signature of person completing form: _____

SECTION 00700 – DRUG FREE WORKPLACE FORM

The undersigned proposer, in accordance with Florida Statute 287.087 hereby certifies that Natures Care Orlando does:

(Name of Business)

1. Publish a statement notifying employees that the unlawful manufacture, distribution, dispensing, possession or use of a controlled substance is prohibited in the workplace and specifying the actions that will be taken against employees for violations of such prohibition.
2. Inform employees about the dangers of drug abuse in the workplace, the business's policy of maintaining a drug-free workplace, any available drug counseling, rehabilitation, and employee assistance programs, and the penalties that may be imposed upon employees for drug abuse violations.
3. Give each employee engaged in providing the commodities or contractual services that are under contract a copy of the Drug-Free statement.
4. Notify the employees that as a condition of working on the commodities or contractual services that are under contract, employee will abide by the terms of the statement and will notify the employer of any conviction of, or plea of guilty or nolo contendere to, any violation of Chapter 893 or of any controlled substance law of the United States or any state, for a violation occurring in the workplace no later than five (5) days after such conviction.
5. Impose a sanction on, or require the satisfactory participation in a drug abuse assistance or rehabilitation program if such is available in the employee's community, by any employee who is so convicted.
6. Make a good faith effort to continue to maintain a drug-free workplace through implementation of this section.

As the person authorized to sign the statement, I certify that this business complies fully with the above requirements.



(Authorized signature)

October 23, 2019

(Date)

Stefan Beaulieu

(Print/type name as signed above)

****THIS FORM MUST BE COMPLETED AND RETURNED WITH YOUR SUBMITTAL.**

NON-COLLUSION AFFIDAVIT OF PRIME RESPONDENT

STATE OF Florida)

COUNTY OF Seminole)

Stefan Beaulieu, being duly sworn, deposes and says that:

(1) He/she is Vice President of Nature's Care
Title Firm/Company

the respondent that has submitted the attached response.

(2) He/she is fully informed respecting the preparation and contents of the attached solicitation and of all pertinent circumstances respecting such solicitation.

(3) Such solicitation is genuine and is not a collusive or sham solicitation.

(4) Neither the said respondent nor any of its officers, partners, owners, agent representatives, employees or parties in interest including this affiant, has in any way, colluded, conspired, or agreed, directly or indirectly, with any other respondent, firm or person, to submit a collusive or sham response in connection with the Agreement for which the attached response has been submitted or to refrain from proposing in connection with such Agreement, or has in any manner, directly or indirectly, sought by Agreement or collusion or communication or conference with any other responder, firm or person to fix the price or prices in the attached solicitation or of any other respondent, or to fix any overhead, profit or cost element of the proposed price or the proposed price of any other responder, or to secure through any collusion, conspiracy, connivance or unlawful Agreement any advantage against the City of Winter Springs, Florida, or any person interested in the proposed Agreement.

(5) The price or prices quoted in the attached response are fair and proper and are not tainted by any collusion, conspiracy, or unlawful Agreement on the part of the proposer or any of its agents, representatives, owners, employees, or parties of interest, including affiant.

[Signature]
(Signed)
Vice President

STATE OF FLORIDA

(Title)

COUNTY OF SEMINOLE

The foregoing instrument was acknowledged before me this 10/23/19 by Stefan Beaulieu, who is personally known to me or who has produced FLIDC as identification and who did (did not) take an oath.

[Signature] (Signature of Notary Public)

Walbert Soto (Name of Notary Typed, Printed or Stamped)

Notary Public GG 42956 (Commission Number)

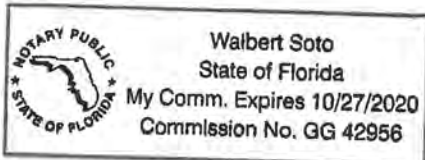

****THIS FORM MUST BE COMPLETED AND RETURNED WITH YOUR SUBMITTAL.**



CERTIFICATE OF LIABILITY INSURANCE

DATE (MM/DD/YYYY)
11/26/2018

THIS CERTIFICATE IS ISSUED AS A MATTER OF INFORMATION ONLY AND CONFERS NO RIGHTS UPON THE CERTIFICATE HOLDER. THIS CERTIFICATE DOES NOT AFFIRMATIVELY OR NEGATIVELY AMEND, EXTEND OR ALTER THE COVERAGE AFFORDED BY THE POLICIES BELOW. THIS CERTIFICATE OF INSURANCE DOES NOT CONSTITUTE A CONTRACT BETWEEN THE ISSUING INSURER(S), AUTHORIZED REPRESENTATIVE OR PRODUCER, AND THE CERTIFICATE HOLDER.

IMPORTANT: If the certificate holder is an ADDITIONAL INSURED, the policy(ies) must be endorsed. If SUBROGATION IS WAIVED, subject to the terms and conditions of the policy, certain policies may require an endorsement. A statement on this certificate does not confer rights to the certificate holder in lieu of such endorsement(s).

PRODUCER Closson Insurance Agency, LLC 1201 S. Orlando Avenue Suite 200 Winter Park FL 32789	CONTACT NAME: Lisa Albright PHONE (A/C, No, Ext): (407) 898-2211 E-MAIL ADDRESS: lalbright@clossoninsurance.com	FAX (A/C, No): (407) 898-1850
	INSURER(S) AFFORDING COVERAGE	
INSURED Nature's Care Orlando LLC 747 Commerce Circle Suite D Longwood FL 32750	INSURER A: Southern-Owners Insurance Co NAIC # 10190	
	INSURER B: Owners Insurance Company NAIC # 32700	
	INSURER C: Associated Industries Ins Co. NAIC # 23140	
	INSURER D:	
	INSURER E:	
	INSURER F:	

COVERAGES **CERTIFICATE NUMBER:** 11.26.18 **REVISION NUMBER:**

THIS IS TO CERTIFY THAT THE POLICIES OF INSURANCE LISTED BELOW HAVE BEEN ISSUED TO THE INSURED NAMED ABOVE FOR THE POLICY PERIOD INDICATED. NOTWITHSTANDING ANY REQUIREMENT, TERM OR CONDITION OF ANY CONTRACT OR OTHER DOCUMENT WITH RESPECT TO WHICH THIS CERTIFICATE MAY BE ISSUED OR MAY PERTAIN, THE INSURANCE AFFORDED BY THE POLICIES DESCRIBED HEREIN IS SUBJECT TO ALL THE TERMS, EXCLUSIONS AND CONDITIONS OF SUCH POLICIES. LIMITS SHOWN MAY HAVE BEEN REDUCED BY PAID CLAIMS.

INSR LTR	TYPE OF INSURANCE	ADDL SUBR INSD WVD	POLICY NUMBER	POLICY EFF (MM/DD/YYYY)	POLICY EXP (MM/DD/YYYY)	LIMITS
A	<input checked="" type="checkbox"/> COMMERCIAL GENERAL LIABILITY <input type="checkbox"/> CLAIMS-MADE <input checked="" type="checkbox"/> OCCUR GEN'L AGGREGATE LIMIT APPLIES PER: <input type="checkbox"/> POLICY <input checked="" type="checkbox"/> PRO-JECT <input type="checkbox"/> LOC OTHER:		72020693	10/14/2018	10/14/2019	EACH OCCURRENCE \$ 1,000,000 DAMAGE TO RENTED PREMISES (Ea occurrence) \$ 300,000 MED EXP (Any one person) \$ 10,000 PERSONAL & ADV INJURY \$ 1,000,000 GENERAL AGGREGATE \$ 2,000,000 PRODUCTS - COMP/OP AGG \$ 2,000,000
B	<input checked="" type="checkbox"/> AUTOMOBILE LIABILITY <input type="checkbox"/> ANY AUTO <input type="checkbox"/> ALL OWNED AUTOS <input type="checkbox"/> SCHEDULED AUTOS <input type="checkbox"/> HIRED AUTOS <input type="checkbox"/> NON-OWNED AUTOS		4966660600	10/14/2018	10/14/2019	COMBINED SINGLE LIMIT (Ea accident) \$ 1,000,000 BODILY INJURY (Per person) \$ BODILY INJURY (Per accident) \$ PROPERTY DAMAGE (Per accident) \$ PIP-Basic \$ 10,000
A	<input checked="" type="checkbox"/> UMBRELLA LIAB <input checked="" type="checkbox"/> OCCUR <input type="checkbox"/> EXCESS LIAB <input type="checkbox"/> CLAIMS-MADE DED <input checked="" type="checkbox"/> RETENTION \$ 0		5002069300	10/14/2018	10/14/2019	EACH OCCURRENCE \$ 1,000,000 AGGREGATE \$ 1,000,000
C	WORKERS COMPENSATION AND EMPLOYERS' LIABILITY ANY PROPRIETOR/PARTNER/EXECUTIVE OFFICER/MEMBER EXCLUDED? (Mandatory in NH) <input type="checkbox"/> Y/N <input checked="" type="checkbox"/> N/A If yes, describe under DESCRIPTION OF OPERATIONS below		AWC1118829	12/3/2018	12/3/2019	<input checked="" type="checkbox"/> PER STATUTE <input type="checkbox"/> OTH-ER E.L. EACH ACCIDENT \$ 1,000,000 E.L. DISEASE - EA EMPLOYEE \$ 1,000,000 E.L. DISEASE - POLICY LIMIT \$ 1,000,000

DESCRIPTION OF OPERATIONS / LOCATIONS / VEHICLES (ACORD 101, Additional Remarks Schedule, may be attached if more space is required)
** FOR INFORMATIONAL PURPOSES ONLY **

CERTIFICATE HOLDER

** FOR INFORMATIONAL PURPOSES ONLY **

CANCELLATION

SHOULD ANY OF THE ABOVE DESCRIBED POLICIES BE CANCELLED BEFORE THE EXPIRATION DATE THEREOF, NOTICE WILL BE DELIVERED IN ACCORDANCE WITH THE POLICY PROVISIONS.

AUTHORIZED REPRESENTATIVE
Team Weis 3, Inc./LMA

© 1988-2014 ACORD CORPORATION. All rights reserved.

Thirty (30) days cancellation notice required.

The undersigned firm agrees to obtain, prior to award, if selected, insurance as stated above.

Stefan Beaulieu / Natures Care Orlando

PROPOSER/BIDDER

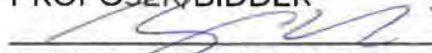

AUTHORIZED SIGNATURE

Vice President

OFFICER TITLE

October 23, 2019

DATE

****THIS FORM MUST BE COMPLETED AND RETURNED WITH YOUR SUBMITTAL.**

Proposal Form



PACKAGE # 3

Respondent Name (Company): Natures Care Orlando

Name and Title of Person Completing Form: Stefan Beaulieu, Vice President

PROPOSED COST

Base Maintenance	\$ 20,026.00 / 240,312.00
Palm Trimming Greater than 13' OA (per tree)	\$ 38.00
Crepe Trimming Greater than 13' OA (per tree)	\$ 18.00
Irrigation Inspections	\$ 1,563.00 / 18,756.00
Mulch- Supplied and Installed (per cubic yard)	\$ 39.50
Fertilizer (per application)	\$ 7,436.00 / 89,232.00
Integrated Pest Management (per application)	\$ 914.00 / 10,968.00
PROPOSAL TOTAL	\$ 30,034.50 / 359,363.50

PLANT, TREE, AND GROUND COVER INSTALLATION

Not to be included as part of proposal review criteria. Price to include all components of installation including staking, watering in, and one-year warranty.

Annuals (Cost plus %)	\$1.85 per flower installed	%
Ground cover (Cost plus %)	\$5.00 average cost installed	%
Shrubs (Cost plus %)	\$14.50 average cost installed	%
Palms (Cost plus %)	depending on size and species	%
Canopy trees (Cost plus %)	depending on size and species	%
Understory trees (Cost plus %)	depending on size and species	%
Sod (Cost plus %)	33	%

Proposal Form continued on next page.

Proposal Form (Continued)



PACKAGE # 3

TREE REMOVAL AND STUMP GRINDING

Not to be included as part of the proposal review criteria. Price to include back fill/sod if needed.

Tree removal 6"	\$ 300
Tree removal 12"	\$ 750
Tree removal 18"	\$ 1,400
Tree removal 24"	\$ 2,150
Tree removal 36"	\$ 3,100

IRRIGATION REPAIR

Not to be included as part of proposal review criteria unless otherwise noted.

Wholesale price of materials plus proposed percentage	40 %
Irrigation Technician Hourly Rate	\$ 55

Signature of person completing form:

SECTION 00700 – DRUG FREE WORKPLACE FORM

The undersigned proposer, in accordance with Florida Statute 287.087 hereby certifies that
Natures Care Orlando does:

(Name of Business)

1. Publish a statement notifying employees that the unlawful manufacture, distribution, dispensing, possession or use of a controlled substance is prohibited in the workplace and specifying the actions that will be taken against employees for violations of such prohibition.
2. Inform employees about the dangers of drug abuse in the workplace, the business's policy of maintaining a drug-free workplace, any available drug counseling, rehabilitation, and employee assistance programs, and the penalties that may be imposed upon employees for drug abuse violations.
3. Give each employee engaged in providing the commodities or contractual services that are under contract a copy of the Drug-Free statement.
4. Notify the employees that as a condition of working on the commodities or contractual services that are under contract, employee will abide by the terms of the statement and will notify the employer of any conviction of, or plea of guilty or nolo contendere to, any violation of Chapter 893 or of any controlled substance law of the United States or any state, for a violation occurring in the workplace no later than five (5) days after such conviction.
5. Impose a sanction on, or require the satisfactory participation in a drug abuse assistance or rehabilitation program if such is available in the employee's community, by any employee who is so convicted.
6. Make a good faith effort to continue to maintain a drug-free workplace through implementation of this section.

As the person authorized to sign the statement, I certify that this business complies fully with the above requirements.



(Authorized signature)

October 23, 2019

(Date)

Stefan Beaulieu

(Print/type name as signed above)

****THIS FORM MUST BE COMPLETED AND RETURNED WITH YOUR SUBMITTAL.**

NON-COLLUSION AFFIDAVIT OF PRIME RESPONDENT

STATE OF Florida)

COUNTY OF Seminole)

Stefan Beaulieu, being duly sworn, deposes and says that:

(1) He/she is Vice Presidency of Natures Care
Title Firm/Company

the respondent that has submitted the attached response.

- (2) He/she is fully informed respecting the preparation and contents of the attached solicitation and of all pertinent circumstances respecting such solicitation.
- (3) Such solicitation is genuine and is not a collusive or sham solicitation.
- (4) Neither the said respondent nor any of its officers, partners, owners, agent representatives, employees or parties in interest including this affiant, has in any way, colluded, conspired, or agreed, directly or indirectly, with any other respondent, firm or person, to submit a collusive or sham response in connection with the Agreement for which the attached response has been submitted or to refrain from proposing in connection with such Agreement, or has in any manner, directly or indirectly, sought by Agreement or collusion or communication or conference with any other responder, firm or person to fix the price or prices in the attached solicitation or of any other respondent, or to fix any overhead, profit or cost element of the proposed price or the proposed price of any other responder, or to secure through any collusion, conspiracy, connivance or unlawful Agreement any advantage against the City of Winter Springs, Florida, or any person interested in the proposed Agreement.
- (5) The price or prices quoted in the attached response are fair and proper and are not tainted by any collusion, conspiracy, or unlawful Agreement on the part of the proposer or any of its agents, representatives, owners, employees, or parties of interest, including affiant.

[Signature]
(Signed)

Vice President
(Title)

STATE OF FLORIDA

COUNTY OF SEMINOLE

The foregoing instrument was acknowledged before me this 10/23/19 by Stefan Beaulieu who is personally known to me or who has produced FL ID as identification and who did (did not) take an oath.

[Signature] (Signature of Notary Public)

Walbert Soto (Name of Notary Typed, Printed or Stamped)

Notary Public GG 42956 (Commission Number)

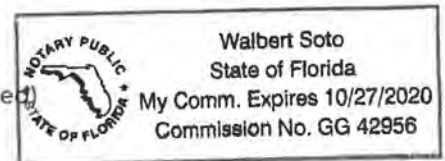

****THIS FORM MUST BE COMPLETED AND RETURNED WITH YOUR SUBMITTAL**

SECTION 00900 – INSURANCE REQUIREMENTS FORM

Insurance Type	Required Limits
----------------	-----------------

- ✓

<p>Worker's Compensation</p>	<p>Statutory Limits of Florida Statutes, Chapter 440 and all Federal Government Statutory Limits</p>
<p>Employer's Liability</p>	<p>\$1,000,000 each accident, single limit per occurrence</p>
<p>Commercial General Liability (Occurrence Form) patterned after the current ISO form</p>	<p>\$1,000,000 single limit per occurrence \$3,000,000 aggregate for Bodily Injury Liability & Property Damage Liability. This shall include Premises and Operations; Independent Contractors; Products & Completed Operations & Contractual Liability.</p>
<p>Indemnification</p>	<p>To the maximum extent permitted by Florida law, the Contractor/Vendor/Consultant shall indemnify and hold harmless City of Winter Springs, its officers and employees from any and all liabilities, damages, losses and costs, including, but not limited to, reasonable attorneys' fees and paralegals' fees, to the extent caused by the negligence, recklessness, or intentional wrongful conduct of the Contractor/Vendor/Consultant or anyone employed or utilized by the Contractor/Vendor/Consultant in the performance of the Agreement. This indemnification obligation shall not be construed to negate, abridge or reduce any other rights or remedies which otherwise may be available to an indemnified party or person described in this paragraph. This section does not pertain to any incident arising from the sole negligence of the City of Winter Springs.</p>
<p>Automobile Liability</p>	<p>\$1,000,000 each person; Bodily Injury & Property Damage, Owned/Non-owned/Hired; Automobile Included.</p>
<p><input type="checkbox"/> Other</p>	

Vendor shall ensure that all subcontractors comply with the same insurance requirements that he/she is required to meet. The same Vendor shall provide the City with certificates of insurance meeting the required insurance provisions.

The City of Winter Springs must be named as "**ADDITIONAL INSURED**" on the Insurance Certificate for Commercial General Liability where required.

The Certificate Holder shall be named as City of Winter Springs.

Thirty (30) days cancellation notice required.

The undersigned firm agrees to obtain, prior to award, if selected, insurance as stated above.

Stefan Beaulieu / Natures Care Orlando

PROPOSER/BIDDER

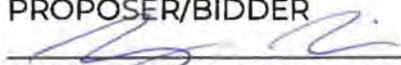

AUTHORIZED SIGNATURE
Vice President

OFFICER TITLE
October 23, 2019

DATE

****THIS FORM MUST BE COMPLETED AND RETURNED WITH YOUR SUBMITTAL.**

Proposal Form



PACKAGE # 4

Respondent Name (Company): Natures Care Orlando

Name and Title of Person Completing Form: Stefan Beaulieu, Vice President

PROPOSED COST

Base Maintenance	\$ 5,247.00 / 62,964.00
Palm Trimming Greater than 13' OA (per tree)	\$ 38.00
Crepe Trimming Greater than 13' OA (per tree)	\$ 18.00
Irrigation Inspections	\$ 241.00 / 2,892.00
Mulch- Supplied and Installed (per cubic yard)	\$ 39.50
Fertilizer (per application)	\$ --
Integrated Pest Management (per application)	\$ --
PROPOSAL TOTAL	\$ 5,583.50 / 65,951.50

PLANT, TREE, AND GROUND COVER INSTALLATION

Not to be included as part of proposal review criteria. Price to include all components of installation including staking, watering in, and one-year warranty.

Annuals (Cost plus %)	\$1.85 per flower installed	%
Ground cover (Cost plus %)	\$5.00 average cost installed	%
Shrubs (Cost plus %)	\$14.50 average cost installed	%
Palms (Cost plus %)	depending on size and species	%
Canopy trees (Cost plus %)	depending on size and species	%
Understory trees (Cost plus %)	depending on size and species	%
Sod (Cost plus %)	33	%

Proposal Form continued on next page.

Proposal Form (Continued)



PACKAGE # 4

TREE REMOVAL AND STUMP GRINDING

Not to be included as part of the proposal review criteria. Price to include back fill/sod if needed.

Tree removal 6"	\$ 300
Tree removal 12"	\$ 750
Tree removal 18"	\$ 1,400
Tree removal 24"	\$ 2,150
Tree removal 36"	\$ 3,100

IRRIGATION REPAIR

Not to be included as part of proposal review criteria unless otherwise noted.

Wholesale price of materials plus proposed percentage	40 %
Irrigation Technician Hourly Rate	\$ 55

Signature of person completing form:

SECTION 00700 – DRUG FREE WORKPLACE FORM

The undersigned proposer, in accordance with Florida Statute 287.087 hereby certifies that Natures Care Orlando does:

(Name of Business)

1. Publish a statement notifying employees that the unlawful manufacture, distribution, dispensing, possession or use of a controlled substance is prohibited in the workplace and specifying the actions that will be taken against employees for violations of such prohibition.
2. Inform employees about the dangers of drug abuse in the workplace, the business's policy of maintaining a drug-free workplace, any available drug counseling, rehabilitation, and employee assistance programs, and the penalties that may be imposed upon employees for drug abuse violations.
3. Give each employee engaged in providing the commodities or contractual services that are under contract a copy of the Drug-Free statement.
4. Notify the employees that as a condition of working on the commodities or contractual services that are under contract, employee will abide by the terms of the statement and will notify the employer of any conviction of, or plea of guilty or nolo contendere to, any violation of Chapter 893 or of any controlled substance law of the United States or any state, for a violation occurring in the workplace no later than five (5) days after such conviction.
5. Impose a sanction on, or require the satisfactory participation in a drug abuse assistance or rehabilitation program if such is available in the employee's community, by any employee who is so convicted.
6. Make a good faith effort to continue to maintain a drug-free workplace through implementation of this section.

As the person authorized to sign the statement, I certify that this business complies fully with the above requirements.



(Authorized signature)

October 23, 2019

(Date)

Stefan Beaulieu

(Print/type name as signed above)

****THIS FORM MUST BE COMPLETED AND RETURNED WITH YOUR SUBMITTAL.**

NON-COLLUSION AFFIDAVIT OF PRIME RESPONDENT

STATE OF Florida)

COUNTY OF Seminole)

Stefan Beaulieu, being duly sworn, deposes and says that:

(1) He/she is Vice President of Natures Care
Title Firm/Company

the respondent that has submitted the attached response.

- (2) He/she is fully informed respecting the preparation and contents of the attached solicitation and of all pertinent circumstances respecting such solicitation.
- (3) Such solicitation is genuine and is not a collusive or sham solicitation.
- (4) Neither the said respondent nor any of its officers, partners, owners, agent representatives, employees or parties in interest including this affiant, has in any way, colluded, conspired, or agreed, directly or indirectly, with any other respondent, firm or person, to submit a collusive or sham response in connection with the Agreement for which the attached response has been submitted or to refrain from proposing in connection with such Agreement, or has in any manner, directly or indirectly, sought by Agreement or collusion or communication or conference with any other responder, firm or person to fix the price or prices in the attached solicitation or of any other respondent, or to fix any overhead, profit or cost element of the proposed price or the proposed price of any other responder, or to secure through any collusion, conspiracy, connivance or unlawful Agreement any advantage against the City of Winter Springs, Florida, or any person interested in the proposed Agreement.
- (5) The price or prices quoted in the attached response are fair and proper and are not tainted by any collusion, conspiracy, or unlawful Agreement on the part of the proposer or any of its agents, representatives, owners, employees, or parties of interest, including affiant.

[Signature]
(Signed)

Vice President
(Title)

STATE OF FLORIDA

COUNTY OF SEMINOLE

The foregoing instrument was acknowledged before me this 10/23/19 by Stefan Beaulieu who is personally known to me or who has produced FL ID as identification and who did (did not) take an oath.

[Signature] (Signature of Notary Public)

Walbert Soto (Name of Notary Typed, Printed or Stamped)

Notary Public GG 42956 (Commission Number)

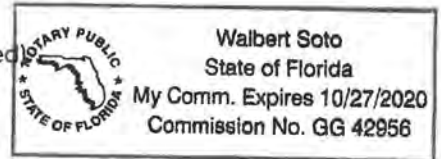

****THIS FORM MUST BE COMPLETED AND RETURNED WITH YOUR SUBMITTAL.**

SECTION 00900 – INSURANCE REQUIREMENTS FORM

Insurance Type	Required Limits
----------------	-----------------

- ✓

Worker's Compensation	Statutory Limits of Florida Statutes, Chapter 440 and all Federal Government Statutory Limits
✓	Employer's Liability
✓	Commercial General Liability (Occurrence Form) patterned after the current ISO form
✓	Indemnification
✓	Automobile Liability
<input type="checkbox"/>	Other

Statutory Limits of Florida Statutes, Chapter 440 and all Federal Government Statutory Limits

\$1,000,000 each accident, single limit per occurrence

\$1,000,000 single limit per occurrence

\$3,000,000 aggregate for Bodily Injury Liability & Property Damage Liability. This shall include Premises and Operations; Independent Contractors; Products & Completed Operations & Contractual Liability.

To the maximum extent permitted by Florida law, the Contractor/Vendor/Consultant shall indemnify and hold harmless City of Winter Springs, its officers and employees from any and all liabilities, damages, losses and costs, including, but not limited to, reasonable attorneys' fees and paralegals' fees, to the extent caused by the negligence, recklessness, or intentional wrongful conduct of the Contractor/Vendor/Consultant or anyone employed or utilized by the Contractor/Vendor/Consultant in the performance of the Agreement. This indemnification obligation shall not be construed to negate, abridge or reduce any other rights or remedies which otherwise may be available to an indemnified party or person described in this paragraph. This section does not pertain to any incident arising from the sole negligence of the City of Winter Springs.

\$1,000,000 each person; Bodily Injury & Property Damage, Owned/Non-owned/Hired; Automobile Included.

Vendor shall ensure that all subcontractors comply with the same insurance requirements that he/she is required to meet. The same Vendor shall provide the City with certificates of insurance meeting the required insurance provisions.

The City of Winter Springs must be named as "**ADDITIONAL INSURED**" on the Insurance Certificate for Commercial General Liability where required.

The Certificate Holder shall be named as City of Winter Springs.



CERTIFICATE OF LIABILITY INSURANCE

DATE (MM/DD/YYYY)
11/26/2018

THIS CERTIFICATE IS ISSUED AS A MATTER OF INFORMATION ONLY AND CONFERS NO RIGHTS UPON THE CERTIFICATE HOLDER. THIS CERTIFICATE DOES NOT AFFIRMATIVELY OR NEGATIVELY AMEND, EXTEND OR ALTER THE COVERAGE AFFORDED BY THE POLICIES BELOW. THIS CERTIFICATE OF INSURANCE DOES NOT CONSTITUTE A CONTRACT BETWEEN THE ISSUING INSURER(S), AUTHORIZED REPRESENTATIVE OR PRODUCER, AND THE CERTIFICATE HOLDER.

IMPORTANT: If the certificate holder is an ADDITIONAL INSURED, the policy(ies) must be endorsed. If SUBROGATION IS WAIVED, subject to the terms and conditions of the policy, certain policies may require an endorsement. A statement on this certificate does not confer rights to the certificate holder in lieu of such endorsement(s).

PRODUCER Closson Insurance Agency, LLC 1201 S. Orlando Avenue Suite 200 Winter Park FL 32789		CONTACT NAME: Lisa Albright PHONE (A/C, No, Ext): (407) 898-2211 FAX (A/C, No): (407) 898-1850 E-MAIL ADDRESS: lalbright@clossoninsurance.com															
INSURED Nature's Care Orlando LLC 747 Commerce Circle Suite D Longwood FL 32750		<table border="1"> <thead> <tr> <th>INSURER(S) AFFORDING COVERAGE</th> <th>NAIC #</th> </tr> </thead> <tbody> <tr> <td>INSURER A: Southern-Owners Insurance Co</td> <td>10190</td> </tr> <tr> <td>INSURER B: Owners Insurance Company</td> <td>32700</td> </tr> <tr> <td>INSURER C: Associated Industries Ins Co.</td> <td>23140</td> </tr> <tr> <td>INSURER D:</td> <td></td> </tr> <tr> <td>INSURER E:</td> <td></td> </tr> <tr> <td>INSURER F:</td> <td></td> </tr> </tbody> </table>		INSURER(S) AFFORDING COVERAGE	NAIC #	INSURER A: Southern-Owners Insurance Co	10190	INSURER B: Owners Insurance Company	32700	INSURER C: Associated Industries Ins Co.	23140	INSURER D:		INSURER E:		INSURER F:	
INSURER(S) AFFORDING COVERAGE	NAIC #																
INSURER A: Southern-Owners Insurance Co	10190																
INSURER B: Owners Insurance Company	32700																
INSURER C: Associated Industries Ins Co.	23140																
INSURER D:																	
INSURER E:																	
INSURER F:																	

COVERAGES	CERTIFICATE NUMBER: 11.26.18	REVISION NUMBER:
------------------	-------------------------------------	-------------------------

THIS IS TO CERTIFY THAT THE POLICIES OF INSURANCE LISTED BELOW HAVE BEEN ISSUED TO THE INSURED NAMED ABOVE FOR THE POLICY PERIOD INDICATED. NOTWITHSTANDING ANY REQUIREMENT, TERM OR CONDITION OF ANY CONTRACT OR OTHER DOCUMENT WITH RESPECT TO WHICH THIS CERTIFICATE MAY BE ISSUED OR MAY PERTAIN, THE INSURANCE AFFORDED BY THE POLICIES DESCRIBED HEREIN IS SUBJECT TO ALL THE TERMS, EXCLUSIONS AND CONDITIONS OF SUCH POLICIES. LIMITS SHOWN MAY HAVE BEEN REDUCED BY PAID CLAIMS.

INSR LTR	TYPE OF INSURANCE	ADDL SUBR INSR WVD	POLICY NUMBER	POLICY EFF (MM/DD/YYYY)	POLICY EXP (MM/DD/YYYY)	LIMITS
A	<input checked="" type="checkbox"/> COMMERCIAL GENERAL LIABILITY <input type="checkbox"/> CLAIMS-MADE <input checked="" type="checkbox"/> OCCUR GEN'L AGGREGATE LIMIT APPLIES PER: <input type="checkbox"/> POLICY <input checked="" type="checkbox"/> PROJECT <input type="checkbox"/> LOC <input type="checkbox"/> OTHER		72020693	10/14/2018	10/14/2019	EACH OCCURRENCE \$ 1,000,000 DAMAGE TO RENTED PREMISES (Ea occurrence) \$ 300,000 MED EXP (Any one person) \$ 10,000 PERSONAL & ADV INJURY \$ 1,000,000 GENERAL AGGREGATE \$ 2,000,000 PRODUCTS - COMP/OP AGG \$ 2,000,000
B	<input checked="" type="checkbox"/> AUTOMOBILE LIABILITY <input type="checkbox"/> ANY AUTO <input type="checkbox"/> ALL OWNED AUTOS <input type="checkbox"/> HIRED AUTOS <input type="checkbox"/> SCHEDULED AUTOS <input type="checkbox"/> NON-OWNED AUTOS		4966660600	10/14/2018	10/14/2019	COMBINED SINGLE LIMIT (Ea accident) \$ 1,000,000 BODILY INJURY (Per person) \$ BODILY INJURY (Per accident) \$ PROPERTY DAMAGE (Per accident) \$ PIP-Basic \$ 10,000
A	<input checked="" type="checkbox"/> UMBRELLA LIAB <input checked="" type="checkbox"/> OCCUR <input type="checkbox"/> EXCESS LIAB <input type="checkbox"/> CLAIMS-MADE DED <input checked="" type="checkbox"/> RETENTION \$ 0		5002069300	10/14/2018	10/14/2019	EACH OCCURRENCE \$ 1,000,000 AGGREGATE \$ 1,000,000
C	WORKERS COMPENSATION AND EMPLOYERS' LIABILITY ANY PROPRIETOR/PARTNER/EXECUTIVE OFFICER/MEMBER EXCLUDED? (Mandatory in NH) If yes, describe under DESCRIPTION OF OPERATIONS below	Y/N <input type="checkbox"/> N/A	AWC1118829	12/3/2018	12/3/2019	<input checked="" type="checkbox"/> PER STATUTE <input type="checkbox"/> OTH-ER E.L. EACH ACCIDENT \$ 1,000,000 E.L. DISEASE - EA EMPLOYEE \$ 1,000,000 E.L. DISEASE - POLICY LIMIT \$ 1,000,000

DESCRIPTION OF OPERATIONS / LOCATIONS / VEHICLES (ACORD 101, Additional Remarks Schedule, may be attached if more space is required)
 ** FOR INFORMATIONAL PURPOSES ONLY **

CERTIFICATE HOLDER**CANCELLATION**

** FOR INFORMATIONAL PURPOSES ONLY **	SHOULD ANY OF THE ABOVE DESCRIBED POLICIES BE CANCELLED BEFORE THE EXPIRATION DATE THEREOF, NOTICE WILL BE DELIVERED IN ACCORDANCE WITH THE POLICY PROVISIONS. AUTHORIZED REPRESENTATIVE Team Weis 3, Inc./LMA
---------------------------------------	--

© 1988-2014 ACORD CORPORATION. All rights reserved.

Thirty (30) days cancellation notice required.

The undersigned firm agrees to obtain, prior to award, if selected, insurance as stated above.

Stefan Beaulieu / Natures Care Orlando

PROPOSER/BIDDER

AUTHORIZED SIGNATURE
Vice President

OFFICER TITLE
October 23, 2019

DATE

****THIS FORM MUST BE COMPLETED AND RETURNED WITH YOUR SUBMITTAL.**

Proposal Form



PACKAGE # 5

Respondent Name (Company): Natures Care Orlando

Name and Title of Person Completing Form: Stefan Beaulieu, Vice President

PROPOSED COST

Base Maintenance	\$ 17,222.00 / 206,664.00
Palm Trimming Greater than 13' OA (per tree)	\$ 38.00
Crepe Trimming Greater than 13' OA (per tree)	\$ 18.00
Irrigation Inspections	\$ 3,656.00 / 43,872.00
Mulch- Supplied and Installed (per cubic yard)	\$ 39.50
Fertilizer (per application)	\$ 1,746.00 / 20,952.00
Integrated Pest Management (per application)	\$ 1,743.00 / 20,916.00
PROPOSAL TOTAL	\$ 24,462.50 / 292,499.50

PLANT, TREE, AND GROUND COVER INSTALLATION

Not to be included as part of proposal review criteria. Price to include all components of installation including staking, watering in, and one-year warranty.

Annuals (Cost plus %)	\$1.85 per flower installed	%
Ground cover (Cost plus %)	\$5.00 average cost installed	%
Shrubs (Cost plus %)	\$14.50 average cost installed	%
Palms (Cost plus %)	depending on size and species	%
Canopy trees (Cost plus %)	depending on size and species	%
Understory trees (Cost plus %)	depending on size and species	%
Sod (Cost plus %)	33	%

Proposal Form continued on next page.

Proposal Form (Continued)



PACKAGE # 5

TREE REMOVAL AND STUMP GRINDING

Not to be included as part of the proposal review criteria. Price to include back fill/sod if needed.

Tree removal 6"	\$ 300
Tree removal 12"	\$ 750
Tree removal 18"	\$ 1,400
Tree removal 24"	\$ 2,150
Tree removal 36"	\$ 3,100

IRRIGATION REPAIR

Not to be included as part of proposal review criteria unless otherwise noted.

Wholesale price of materials plus proposed percentage	40 %
Irrigation Technician Hourly Rate	\$ 55

Signature of person completing form:

SECTION 00700 – DRUG FREE WORKPLACE FORM

The undersigned proposer, in accordance with Florida Statute 287.087 hereby certifies that Natures Care Orlando does:

(Name of Business)

1. Publish a statement notifying employees that the unlawful manufacture, distribution, dispensing, possession or use of a controlled substance is prohibited in the workplace and specifying the actions that will be taken against employees for violations of such prohibition.
2. Inform employees about the dangers of drug abuse in the workplace, the business's policy of maintaining a drug-free workplace, any available drug counseling, rehabilitation, and employee assistance programs, and the penalties that may be imposed upon employees for drug abuse violations.
3. Give each employee engaged in providing the commodities or contractual services that are under contract a copy of the Drug-Free statement.
4. Notify the employees that as a condition of working on the commodities or contractual services that are under contract, employee will abide by the terms of the statement and will notify the employer of any conviction of, or plea of guilty or nolo contendere to, any violation of Chapter 893 or of any controlled substance law of the United States or any state, for a violation occurring in the workplace no later than five (5) days after such conviction.
5. Impose a sanction on, or require the satisfactory participation in a drug abuse assistance or rehabilitation program if such is available in the employee's community, by any employee who is so convicted.
6. Make a good faith effort to continue to maintain a drug-free workplace through implementation of this section.

As the person authorized to sign the statement, I certify that this business complies fully with the above requirements.



(Authorized signature)

October 23, 2019

(Date)

Stefan Beaulieu

(Print/type name as signed above)

****THIS FORM MUST BE COMPLETED AND RETURNED WITH YOUR SUBMITTAL.**

NON-COLLUSION AFFIDAVIT OF PRIME RESPONDENT

STATE OF Florida)

COUNTY OF Seminole)

Stefan Beaulieu, being duly sworn, deposes and says that:

(1) He/she is Vice President of Natures Care,
Title Firm/Company

the respondent that has submitted the attached response.

(2) He/she is fully informed respecting the preparation and contents of the attached solicitation and of all pertinent circumstances respecting such solicitation.

(3) Such solicitation is genuine and is not a collusive or sham solicitation.

(4) Neither the said respondent nor any of its officers, partners, owners, agent representatives, employees or parties in interest including this affiant, has in any way, colluded, conspired, or agreed, directly or indirectly, with any other respondent, firm or person, to submit a collusive or sham response in connection with the Agreement for which the attached response has been submitted or to refrain from proposing in connection with such Agreement, or has in any manner, directly or indirectly, sought by Agreement or collusion or communication or conference with any other responder, firm or person to fix the price or prices in the attached solicitation or of any other respondent, or to fix any overhead, profit or cost element of the proposed price or the proposed price of any other responder, or to secure through any collusion, conspiracy, connivance or unlawful Agreement any advantage against the City of Winter Springs, Florida, or any person interested in the proposed Agreement.

(5) The price or prices quoted in the attached response are fair and proper and are not tainted by any collusion, conspiracy, or unlawful Agreement on the part of the proposer or any of its agents, representatives, owners, employees, or parties of interest, including affiant.

[Signature]

(Signed)
Vice President

(Title)

STATE OF FLORIDA

COUNTY OF SEMINOLE

The foregoing instrument was acknowledged before me this 10/23/19 by Stefan Beaulieu,
who is personally known to me or who has produced FL/DL as identification and who
did (did not) take an oath.

[Signature]
Walbert Soto

(Signature of Notary Public)
(Name of Notary Typed, Printed or Stamped)

Notary Public GG 42956 (Commission Number)

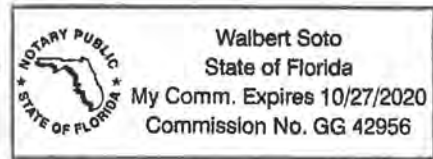

****THIS FORM MUST BE COMPLETED AND RETURNED WITH YOUR SUBMITTAL.**

SECTION 00900 – INSURANCE REQUIREMENTS FORM

Insurance Type	Required Limits
----------------	-----------------

- | | |
|---|---|
| <input checked="" type="checkbox"/> Worker's Compensation | Statutory Limits of Florida Statutes, Chapter 440 and all Federal Government Statutory Limits |
| <input checked="" type="checkbox"/> Employer's Liability | \$1,000,000 each accident, single limit per occurrence |
| <input checked="" type="checkbox"/> Commercial General Liability (Occurrence Form) patterned after the current ISO form | \$1,000,000 single limit per occurrence
\$3,000,000 aggregate for Bodily Injury Liability & Property Damage Liability. This shall include Premises and Operations; Independent Contractors; Products & Completed Operations & Contractual Liability. |
| <input checked="" type="checkbox"/> Indemnification | To the maximum extent permitted by Florida law, the Contractor/Vendor/Consultant shall indemnify and hold harmless City of Winter Springs, its officers and employees from any and all liabilities, damages, losses and costs, including, but not limited to, reasonable attorneys' fees and paralegals' fees, to the extent caused by the negligence, recklessness, or intentional wrongful conduct of the Contractor/Vendor/Consultant or anyone employed or utilized by the Contractor/Vendor/Consultant in the performance of the Agreement. This indemnification obligation shall not be construed to negate, abridge or reduce any other rights or remedies which otherwise may be available to an indemnified party or person described in this paragraph. This section does not pertain to any incident arising from the sole negligence of the City of Winter Springs. |
| <input checked="" type="checkbox"/> Automobile Liability | \$1,000,000 each person; Bodily Injury & Property Damage, Owned/Non-owned/Hired; Automobile Included. |
| <input type="checkbox"/> Other | |

Vendor shall ensure that all subcontractors comply with the same insurance requirements that he/she is required to meet. The same Vendor shall provide the City with certificates of insurance meeting the required insurance provisions.

The City of Winter Springs must be named as "**ADDITIONAL INSURED**" on the Insurance Certificate for Commercial General Liability where required.

The Certificate Holder shall be named as City of Winter Springs.

Thirty (30) days cancellation notice required.

The undersigned firm agrees to obtain, prior to award, if selected, insurance as stated above.

Stefan Beaulieu / Natures Care Orlando

PROPOSER/BIDDER



AUTHORIZED SIGNATURE

Vice President

OFFICER TITLE

October 23, 2019

DATE

****THIS FORM MUST BE COMPLETED AND RETURNED WITH YOUR SUBMITTAL.**

Proposal Form



PACKAGE # 6

Respondent Name (Company): Natures Care Orlando

Name and Title of Person Completing Form: Stefan Beaulieu, Vice President

PROPOSED COST

Base Maintenance	\$ 5,754.00 / 69,048.00
Palm Trimming Greater than 13' OA (per tree)	\$ 38.00
Crepe Trimming Greater than 13' OA (per tree)	\$ 18.00
Irrigation Inspections	\$ --
Mulch- Supplied and Installed (per cubic yard)	\$ 39.50
Fertilizer (per application)	\$ --
Integrated Pest Management (per application)	\$ --
PROPOSAL TOTAL	\$ 5,849.50 / 69,143.50

PLANT, TREE, AND GROUND COVER INSTALLATION

Not to be included as part of proposal review criteria. Price to include all components of installation including staking, watering in, and one-year warranty.

Annuals (Cost plus %)	\$1.85 per flower installed	%
Ground cover (Cost plus %)	\$5.00 average cost installed	%
Shrubs (Cost plus %)	\$14.50 average cost installed	%
Palms (Cost plus %)	depending on size and species	%
Canopy trees (Cost plus %)	depending on size and species	%
Understory trees (Cost plus %)	depending on size and species	%
Sod (Cost plus %)	33	%

Proposal Form continued on next page.

Proposal Form (Continued)



PACKAGE # 6

TREE REMOVAL AND STUMP GRINDING

Not to be included as part of the proposal review criteria. Price to include back fill/sod if needed.

Tree removal 6"	\$ 300
Tree removal 12"	\$ 750
Tree removal 18"	\$ 1,400
Tree removal 24"	\$ 2,150
Tree removal 36"	\$ 3,100

IRRIGATION REPAIR

Not to be included as part of proposal review criteria unless otherwise noted.

Wholesale price of materials plus proposed percentage	40	%
Irrigation Technician Hourly Rate	\$ 55	

Signature of person completing form: _____

SECTION 00700 – DRUG FREE WORKPLACE FORM

The undersigned proposer, in accordance with Florida Statute 287.087 hereby certifies that
Natures Care Orlando does:

(Name of Business)

1. Publish a statement notifying employees that the unlawful manufacture, distribution, dispensing, possession or use of a controlled substance is prohibited in the workplace and specifying the actions that will be taken against employees for violations of such prohibition.
2. Inform employees about the dangers of drug abuse in the workplace, the business's policy of maintaining a drug-free workplace, any available drug counseling, rehabilitation, and employee assistance programs, and the penalties that may be imposed upon employees for drug abuse violations.
3. Give each employee engaged in providing the commodities or contractual services that are under contract a copy of the Drug-Free statement.
4. Notify the employees that as a condition of working on the commodities or contractual services that are under contract, employee will abide by the terms of the statement and will notify the employer of any conviction of, or plea of guilty or nolo contendere to, any violation of Chapter 893 or of any controlled substance law of the United States or any state, for a violation occurring in the workplace no later than five (5) days after such conviction.
5. Impose a sanction on, or require the satisfactory participation in a drug abuse assistance or rehabilitation program if such is available in the employee's community, by any employee who is so convicted.
6. Make a good faith effort to continue to maintain a drug-free workplace through implementation of this section.

As the person authorized to sign the statement, I certify that this business complies fully with the above requirements.



(Authorized signature)

October 23, 2019

(Date)

Stefan Beaulieu

(Print/type name as signed above)

****THIS FORM MUST BE COMPLETED AND RETURNED WITH YOUR SUBMITTAL.**

NON-COLLUSION AFFIDAVIT OF PRIME RESPONDENT

STATE OF Florida)

COUNTY OF Seminole)

Stefan Beaulieu, being duly sworn, deposes and says that:

(1) He/she is Vice President of Natures Care
Title Firm/Company

the respondent that has submitted the attached response.

(2) He/she is fully informed respecting the preparation and contents of the attached solicitation and of all pertinent circumstances respecting such solicitation.

(3) Such solicitation is genuine and is not a collusive or sham solicitation.

(4) Neither the said respondent nor any of its officers, partners, owners, agent representatives, employees or parties in interest including this affiant, has in any way, colluded, conspired, or agreed, directly or indirectly, with any other respondent, firm or person, to submit a collusive or sham response in connection with the Agreement for which the attached response has been submitted or to refrain from proposing in connection with such Agreement, or has in any manner, directly or indirectly, sought by Agreement or collusion or communication or conference with any other responder, firm or person to fix the price or prices in the attached solicitation or of any other respondent, or to fix any overhead, profit or cost element of the proposed price or the proposed price of any other responder, or to secure through any collusion, conspiracy, connivance or unlawful Agreement any advantage against the City of Winter Springs, Florida, or any person interested in the proposed Agreement.

(5) The price or prices quoted in the attached response are fair and proper and are not tainted by any collusion, conspiracy, or unlawful Agreement on the part of the proposer or any of its agents, representatives, owners, employees, or parties of interest, including affiant.

[Signature]

(Signed)
Vice President

STATE OF FLORIDA (Title)

COUNTY OF SEMINOLE

The foregoing instrument was acknowledged before me this 10/23/19 by Stefan Beaulieu who is personally known to me or who has produced FCIDC as identification and who did (did not) take an oath.

[Signature] (Signature of Notary Public)

Walbert Soto (Name of Notary Typed, Printed or Stamped)

Notary Public GG 42956 (Commission Number)

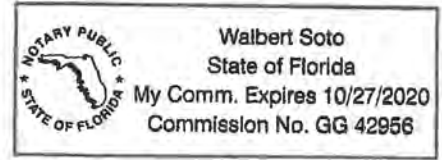

****THIS FORM MUST BE COMPLETED AND RETURNED WITH YOUR SUBMITTAL.**

SECTION 00900 – INSURANCE REQUIREMENTS FORM

Insurance Type	Required Limits
----------------	-----------------

- | | |
|---|---|
| <input checked="" type="checkbox"/> Worker's Compensation | Statutory Limits of Florida Statutes, Chapter 440 and all Federal Government Statutory Limits |
| <input checked="" type="checkbox"/> Employer's Liability | \$1,000,000 each accident, single limit per occurrence |
| <input checked="" type="checkbox"/> Commercial General Liability (Occurrence Form) patterned after the current ISO form | \$1,000,000 single limit per occurrence

\$3,000,000 aggregate for Bodily Injury Liability & Property Damage Liability. This shall include Premises and Operations; Independent Contractors; Products & Completed Operations & Contractual Liability. |
| <input checked="" type="checkbox"/> Indemnification | To the maximum extent permitted by Florida law, the Contractor/Vendor/Consultant shall indemnify and hold harmless City of Winter Springs, its officers and employees from any and all liabilities, damages, losses and costs, including, but not limited to, reasonable attorneys' fees and paralegals' fees, to the extent caused by the negligence, recklessness, or intentional wrongful conduct of the Contractor/Vendor/Consultant or anyone employed or utilized by the Contractor/Vendor/Consultant in the performance of the Agreement. This indemnification obligation shall not be construed to negate, abridge or reduce any other rights or remedies which otherwise may be available to an indemnified party or person described in this paragraph. This section does not pertain to any incident arising from the sole negligence of the City of Winter Springs. |
| <input checked="" type="checkbox"/> Automobile Liability | \$1,000,000 each person; Bodily Injury & Property Damage, Owned/Non-owned/Hired; Automobile Included. |
| <input type="checkbox"/> Other | |

Vendor shall ensure that all subcontractors comply with the same insurance requirements that he/she is required to meet. The same Vendor shall provide the City with certificates of insurance meeting the required insurance provisions.

The City of Winter Springs must be named as "**ADDITIONAL INSURED**" on the Insurance Certificate for Commercial General Liability where required.

The Certificate Holder shall be named as City of Winter Springs.



CERTIFICATE OF LIABILITY INSURANCE

DATE (MM/DD/YYYY)
11/26/2018

THIS CERTIFICATE IS ISSUED AS A MATTER OF INFORMATION ONLY AND CONFERS NO RIGHTS UPON THE CERTIFICATE HOLDER. THIS CERTIFICATE DOES NOT AFFIRMATIVELY OR NEGATIVELY AMEND, EXTEND OR ALTER THE COVERAGE AFFORDED BY THE POLICIES BELOW. THIS CERTIFICATE OF INSURANCE DOES NOT CONSTITUTE A CONTRACT BETWEEN THE ISSUING INSURER(S), AUTHORIZED REPRESENTATIVE OR PRODUCER, AND THE CERTIFICATE HOLDER.

IMPORTANT: If the certificate holder is an ADDITIONAL INSURED, the policy(ies) must be endorsed. If SUBROGATION IS WAIVED, subject to the terms and conditions of the policy, certain policies may require an endorsement. A statement on this certificate does not confer rights to the certificate holder in lieu of such endorsement(s).

PRODUCER Closson Insurance Agency, LLC 1201 S. Orlando Avenue Suite 200 Winter Park FL 32789	CONTACT NAME: Lisa Albright PHONE (A/C, No, Ext): (407) 898-2211 E-MAIL ADDRESS: lalbright@clossoninsurance.com	FAX (A/C, No): (407) 898-1850													
	<table border="1"> <thead> <tr> <th>INSURER(S) AFFORDING COVERAGE</th> <th>NAIC #</th> </tr> </thead> <tbody> <tr> <td>INSURER A: Southern-Owners Insurance Co</td> <td>10190</td> </tr> <tr> <td>INSURER B: Owners Insurance Company</td> <td>32700</td> </tr> <tr> <td>INSURER C: Associated Industries Ins Co.</td> <td>23140</td> </tr> <tr> <td>INSURER D:</td> <td></td> </tr> <tr> <td>INSURER E:</td> <td></td> </tr> <tr> <td>INSURER F:</td> <td></td> </tr> </tbody> </table>		INSURER(S) AFFORDING COVERAGE	NAIC #	INSURER A: Southern-Owners Insurance Co	10190	INSURER B: Owners Insurance Company	32700	INSURER C: Associated Industries Ins Co.	23140	INSURER D:		INSURER E:		INSURER F:
INSURER(S) AFFORDING COVERAGE	NAIC #														
INSURER A: Southern-Owners Insurance Co	10190														
INSURER B: Owners Insurance Company	32700														
INSURER C: Associated Industries Ins Co.	23140														
INSURER D:															
INSURER E:															
INSURER F:															

COVERAGES **CERTIFICATE NUMBER:** 11.26.18 **REVISION NUMBER:**

THIS IS TO CERTIFY THAT THE POLICIES OF INSURANCE LISTED BELOW HAVE BEEN ISSUED TO THE INSURED NAMED ABOVE FOR THE POLICY PERIOD INDICATED. NOTWITHSTANDING ANY REQUIREMENT, TERM OR CONDITION OF ANY CONTRACT OR OTHER DOCUMENT WITH RESPECT TO WHICH THIS CERTIFICATE MAY BE ISSUED OR MAY PERTAIN, THE INSURANCE AFFORDED BY THE POLICIES DESCRIBED HEREIN IS SUBJECT TO ALL THE TERMS, EXCLUSIONS AND CONDITIONS OF SUCH POLICIES. LIMITS SHOWN MAY HAVE BEEN REDUCED BY PAID CLAIMS.

INSR LTR	TYPE OF INSURANCE	ADDL SUBR INSD WVD	POLICY NUMBER	POLICY EFF (MM/DD/YYYY)	POLICY EXP (MM/DD/YYYY)	LIMITS
A	<input checked="" type="checkbox"/> COMMERCIAL GENERAL LIABILITY CLAIMS-MADE <input checked="" type="checkbox"/> OCCUR GEN'L AGGREGATE LIMIT APPLIES PER: <input type="checkbox"/> POLICY <input checked="" type="checkbox"/> PROJECT <input type="checkbox"/> LOC OTHER:		72020693	10/14/2018	10/14/2019	EACH OCCURRENCE \$ 1,000,000 DAMAGE TO RENTED PREMISES (Ea occurrence) \$ 300,000 MED EXP (Any one person) \$ 10,000 PERSONAL & ADV INJURY \$ 1,000,000 GENERAL AGGREGATE \$ 2,000,000 PRODUCTS - COMP/OP AGG \$ 2,000,000
B	<input checked="" type="checkbox"/> AUTOMOBILE LIABILITY <input checked="" type="checkbox"/> ANY AUTO <input type="checkbox"/> ALL OWNED AUTOS <input type="checkbox"/> SCHEDULED AUTOS <input type="checkbox"/> HIRED AUTOS <input type="checkbox"/> NON-OWNED AUTOS		4966660600	10/14/2018	10/14/2019	COMBINED SINGLE LIMIT (Ea accident) \$ 1,000,000 BODILY INJURY (Per person) \$ BODILY INJURY (Per accident) \$ PROPERTY DAMAGE (Per accident) \$ PIP-Basic \$ 10,000
A	<input checked="" type="checkbox"/> UMBRELLA LIAB <input checked="" type="checkbox"/> OCCUR <input checked="" type="checkbox"/> EXCESS LIAB <input type="checkbox"/> CLAIMS-MADE DED <input checked="" type="checkbox"/> RETENTION \$ 0		5002069300	10/14/2018	10/14/2019	EACH OCCURRENCE \$ 1,000,000 AGGREGATE \$ 1,000,000
C	WORKERS COMPENSATION AND EMPLOYERS' LIABILITY ANY PROPRIETOR/PARTNER/EXECUTIVE OFFICER/MEMBER EXCLUDED? (Mandatory in NH) If yes, describe under DESCRIPTION OF OPERATIONS below	Y/N <input type="checkbox"/> N/A	AWC1118829	12/3/2018	12/3/2019	<input checked="" type="checkbox"/> PER STATUTE <input type="checkbox"/> OTHER E.L. EACH ACCIDENT \$ 1,000,000 E.L. DISEASE - EA EMPLOYEE \$ 1,000,000 E.L. DISEASE - POLICY LIMIT \$ 1,000,000

DESCRIPTION OF OPERATIONS / LOCATIONS / VEHICLES (ACORD 101, Additional Remarks Schedule, may be attached if more space is required)
** FOR INFORMATIONAL PURPOSES ONLY **

CERTIFICATE HOLDER

CANCELLATION

** FOR INFORMATIONAL PURPOSES ONLY **	SHOULD ANY OF THE ABOVE DESCRIBED POLICIES BE CANCELLED BEFORE THE EXPIRATION DATE THEREOF, NOTICE WILL BE DELIVERED IN ACCORDANCE WITH THE POLICY PROVISIONS. AUTHORIZED REPRESENTATIVE Team Weis 3, Inc./LMA
--	--

© 1988-2014 ACORD CORPORATION. All rights reserved.

Thirty (30) days cancellation notice required.

The undersigned firm agrees to obtain, prior to award, if selected, insurance as stated above.

Stefan Beaulieu / Natures Care Orlando

PROPOSER/BIDDER

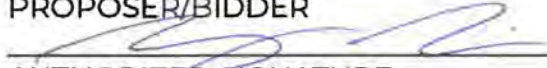

AUTHORIZED SIGNATURE

Vice President

OFFICER TITLE

October 23, 2019

DATE

****THIS FORM MUST BE COMPLETED AND RETURNED WITH YOUR SUBMITTAL.**

Proposal Form



PACKAGE # 7

Respondent Name (Company): Natures Care Orlando

Name and Title of Person Completing Form: Stefan Beaulieu, Vice President

PROPOSED COST

Base Maintenance	\$ 26,727.00 / 320,844.00
Palm Trimming Greater than 13' OA (per tree)	\$ 38.00
Crepe Trimming Greater than 13' OA (per tree)	\$ 18.00
Irrigation Inspections	\$ --
Mulch- Supplied and Installed (per cubic yard)	\$ 39.50
Fertilizer (per application)	\$ --
Integrated Pest Management (per application)	\$ --
PROPOSAL TOTAL	\$ 26,822.50 / 320,939.50

PLANT, TREE, AND GROUND COVER INSTALLATION

Not to be included as part of proposal review criteria. Price to include all components of installation including staking, watering in, and one-year warranty.

Annuals (Cost plus %)	\$1.85 per flower installed	%
Ground cover (Cost plus %)	\$5.00 average cost installed	%
Shrubs (Cost plus %)	\$14.50 average cost installed	%
Palms (Cost plus %)	depending on size and species	%
Canopy trees (Cost plus %)	depending on size and species	%
Understory trees (Cost plus %)	depending on size and species	%
Sod (Cost plus %)	33	%

/

Proposal Form continued on next page.

Proposal Form (Continued)



PACKAGE # 7

TREE REMOVAL AND STUMP GRINDING

Not to be included as part of the proposal review criteria. Price to include back fill/sod if needed.

Tree removal 6"	\$ 300
Tree removal 12"	\$ 750
Tree removal 18"	\$ 1,400
Tree removal 24"	\$ 2,150
Tree removal 36"	\$ 3,100

IRRIGATION REPAIR

Not to be included as part of proposal review criteria unless otherwise noted.

Wholesale price of materials plus proposed percentage	40	%
Irrigation Technician Hourly Rate	\$ 55	

Signature of person completing form: _____

SECTION 00700 – DRUG FREE WORKPLACE FORM

The undersigned proposer, in accordance with Florida Statute 287.087 hereby certifies that Natures Care Orlando does:

(Name of Business)

1. Publish a statement notifying employees that the unlawful manufacture, distribution, dispensing, possession or use of a controlled substance is prohibited in the workplace and specifying the actions that will be taken against employees for violations of such prohibition.
2. Inform employees about the dangers of drug abuse in the workplace, the business's policy of maintaining a drug-free workplace, any available drug counseling, rehabilitation, and employee assistance programs, and the penalties that may be imposed upon employees for drug abuse violations.
3. Give each employee engaged in providing the commodities or contractual services that are under contract a copy of the Drug-Free statement.
4. Notify the employees that as a condition of working on the commodities or contractual services that are under contract, employee will abide by the terms of the statement and will notify the employer of any conviction of, or plea of guilty or nolo contendere to, any violation of Chapter 893 or of any controlled substance law of the United States or any state, for a violation occurring in the workplace no later than five (5) days after such conviction.
5. Impose a sanction on, or require the satisfactory participation in a drug abuse assistance or rehabilitation program if such is available in the employee's community, by any employee who is so convicted.
6. Make a good faith effort to continue to maintain a drug-free workplace through implementation of this section.

As the person authorized to sign the statement, I certify that this business complies fully with the above requirements.



(Authorized signature)

October 23, 2019

(Date)

Stefan Beaulieu

(Print/type name as signed above)

****THIS FORM MUST BE COMPLETED AND RETURNED WITH YOUR SUBMITTAL.**

NON-COLLUSION AFFIDAVIT OF PRIME RESPONDENT

STATE OF Florida)

COUNTY OF Seminole)

Stefan Beaukieu, being duly sworn, deposes and says that:

(1) He/she is Vice President of Natures Care
Title Firm/Company

the respondent that has submitted the attached response.

- (2) He/she is fully informed respecting the preparation and contents of the attached solicitation and of all pertinent circumstances respecting such solicitation.
- (3) Such solicitation is genuine and is not a collusive or sham solicitation.
- (4) Neither the said respondent nor any of its officers, partners, owners, agent representatives, employees or parties in interest including this affiant, has in any way, colluded, conspired, or agreed, directly or indirectly, with any other respondent, firm or person, to submit a collusive or sham response in connection with the Agreement for which the attached response has been submitted or to refrain from proposing in connection with such Agreement, or has in any manner, directly or indirectly, sought by Agreement or collusion or communication or conference with any other responder, firm or person to fix the price or prices in the attached solicitation or of any other respondent, or to fix any overhead, profit or cost element of the proposed price or the proposed price of any other responder, or to secure through any collusion, conspiracy, connivance or unlawful Agreement any advantage against the City of Winter Springs, Florida, or any person interested in the proposed Agreement.
- (5) The price or prices quoted in the attached response are fair and proper and are not tainted by any collusion, conspiracy, or unlawful Agreement on the part of the proposer or any of its agents, representatives, owners, employees, or parties of interest, including affiant.

[Signature]

(Signed)
Vice President

(Title)

STATE OF FLORIDA

COUNTY OF SEMINOLE

The foregoing instrument was acknowledged before me this 10/23/19 by Stefan Beaukieu who is personally known to me or who has produced FLIPC as identification and who did (did not) take an oath.

[Signature] (Signature of Notary Public)

Walbert Soto (Name of Notary Typed, Printed or Stamped)

Notary Public 4242956 (Commission Number)

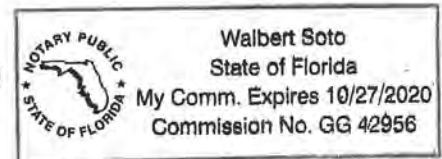

****THIS FORM MUST BE COMPLETED AND RETURNED WITH YOUR SUBMITTAL.**

SECTION 00900 – INSURANCE REQUIREMENTS FORM

Insurance Type	Required Limits
✓ Worker's Compensation	Statutory Limits of Florida Statutes, Chapter 440 and all Federal Government Statutory Limits
✓ Employer's Liability	\$1,000,000 each accident, single limit per occurrence
✓ Commercial General Liability (Occurrence Form) patterned after the current ISO form	\$1,000,000 single limit per occurrence \$3,000,000 aggregate for Bodily Injury Liability & Property Damage Liability. This shall include Premises and Operations; Independent Contractors; Products & Completed Operations & Contractual Liability.
✓ Indemnification	To the maximum extent permitted by Florida law, the Contractor/Vendor/Consultant shall indemnify and hold harmless City of Winter Springs, its officers and employees from any and all liabilities, damages, losses and costs, including, but not limited to, reasonable attorneys' fees and paralegals' fees, to the extent caused by the negligence, recklessness, or intentional wrongful conduct of the Contractor/Vendor/Consultant or anyone employed or utilized by the Contractor/Vendor/Consultant in the performance of the Agreement. This indemnification obligation shall not be construed to negate, abridge or reduce any other rights or remedies which otherwise may be available to an indemnified party or person described in this paragraph. This section does not pertain to any incident arising from the sole negligence of the City of Winter Springs.
✓ Automobile Liability	\$1,000,000 each person; Bodily Injury & Property Damage, Owned/Non-owned/Hired; Automobile Included.
<input type="checkbox"/> Other	

Vendor shall ensure that all subcontractors comply with the same insurance requirements that he/she is required to meet. The same Vendor shall provide the City with certificates of insurance meeting the required insurance provisions.

The City of Winter Springs must be named as "**ADDITIONAL INSURED**" on the Insurance Certificate for Commercial General Liability where required.

The Certificate Holder shall be named as City of Winter Springs.

Thirty (30) days cancellation notice required.

The undersigned firm agrees to obtain, prior to award, if selected, insurance as stated above.

Stefan Beaulieu / Natures Care Orlando

PROPOSER/BIDDER



AUTHORIZED SIGNATURE
Vice President

OFFICER TITLE
October 23, 2019

DATE

****THIS FORM MUST BE COMPLETED AND RETURNED WITH YOUR SUBMITTAL.**

Caligreen Landscaping

Aaron Spencer

BID PROPOSAL PACKAGE 1- City of Winter Springs Municipal

Facilities:

1. Vacant Public Works Admin Building- 110 N. Flamingo Ave
2. City Hall- 1126 E. SR 434
3. Police Department- 300 N. Moss Road
4. Public Works Compound- 150 N. Hartman Lane
5. Old Water Treatment Plant #1- 1 First Ct.
6. Water Treatment Plant #2- 700 Sheoah Blvd.
7. Water Treatment Plant #3- 110 W. Bahama Rd
8. East Water Treatment Plant- 851 Northern Way
9. West Water Treatment Plant- 1000 W. State Road 434
10. East Wastewater Plant- 1560 Winter Springs Blvd.
11. West Wastewater Plant- 1000 W. State Road 434
12. Oak Forest Wastewater Plant- 1001 Papaya Ln.
13. Lake Jessup Water Augmentation Plant 1000 Central Winds Park

Weekly Landscaping Services: (3/15 – 10/15), Bi-Weekly Landscaping Services: (10/16 – 3/14)

Services to be performed include: mowing, blowing, trimming hedges, weed-eating, edging, pruning trees, removing spanish moss, trash removal, fertilization (as directed), annual flower rotation (as requested), insect and disease control (as required), irrigation inspection and repair (monthly/as required) and other additional services, as requested.

Grass cutting height may be adjusted to maintain a turf height of between 2-½ to 3 inches for Bahia, 4 to 5 inches for St. Augustine. Grass clippings shall be removed from the turf to avoid thatch build-up.

* Edging will be performed on all walkways, curbs, and edging of pavements. This will be performed every time we come out to complete services.

* Weed-eating will be performed on all the beds and sidewalks (pavement areas).

* All trash will be picked up before the service is started.

* Blowing debris off walkways, parking lots, etc., will be performed upon completion of services.

Caligreen Landscaping

Aaron Spencer- Owner

Been in business of 10 years

I started for working in the landscaping field in 2001 when I started working for Commercial maintenance of central Florida. I worked for that company for 10 years as a foreman. I then went to work for Lawn team for the summer when they let me go when the winter time started. That is when I decided I wanted to start my own landscaping company. I started very small pushing my push mower around the neighborhood due to not having a truck, and started getting customers. Then little by little I bought more and more equipment till I got a truck, trailer, and all the landscaping tools that I needed to expand and go further than my neighborhood. That is when my wife started to come out with me and we did the properties together. Fast-forward to this past summer to when I got the best opportunity to work for the City of Winter Springs and maintain the municipal facilities. I have started there about June till present. I have experience in sod placement, planting, mulching, trimming, clean-ups, ex. Landscaping is something that I have a lot of passion in and love doing. As of now it is myself (Aaron Spencer-owner) I have one employee Chris as of now we do all the work as we are able to complete the amount of work we currently have with the two of us. I am willing and trying to find more employees as needed.

References:

Rosemary Mora

904-330-5752

Sammy Shehatas

321-282-8627

Jerry Irrigation

407-913-5528

Proposal Form



PACKAGE # 1

Respondent Name (Company): Caligreen Landscaping

Name and Title of Person Completing Form:

Aaron Spencer - Owner

	<u>PROPOSED</u> <u>COST</u>
Base Maintenance	\$ 4,260
Palm Trimming Greater than 13' OA (per tree)	\$ 75
Crepe Trimming Greater than 13' OA (per tree)	\$ 30
Irrigation Inspections	\$ 75
Mulch- Supplied and Installed (per cubic yard)	\$ 110
Fertilizer (per application)	\$ 110
Integrated Pest Management (per application)	\$ 40
PROPOSAL TOTAL	\$ 4,700

PLANT, TREE, AND GROUND COVER INSTALLATION

Not to be included as part of proposal review criteria. Price to include all components of installation including staking, watering in, and one-year warranty.

Annuals (Cost plus %)	65	%
Ground cover (Cost plus %)	50	%
Shrubs (Cost plus %)	75	%
Palms (Cost plus %)	70	%
Canopy trees (Cost plus %)	85	%
Understory trees (Cost plus %)	80	%
Sod (Cost plus %)	90	%

Proposal Form (Continued)



PACKAGE #

1

TREE REMOVAL AND STUMP GRINDING

Not to be included as part of the proposal review criteria. Price to include back fill/sod if needed.

Tree removal 6"	\$	225
Tree removal 12"	\$	500
Tree removal 18"	\$	620
Tree removal 24"	\$	720
Tree removal 36"	\$	1000

IRRIGATION REPAIR

Not to be included as part of proposal review criteria unless otherwise noted.

Wholesale price of materials plus proposed percentage		50	%
Irrigation Technician Hourly Rate	\$	17	

Signature of person completing form:

Aaron Spencer

SECTION 00700 - DRUG FREE WORKPLACE FORM

The undersigned proposer, in accordance with Florida Statute 287.087 hereby certifies that

Caligreen Landscaping does:
(Name of Business)

1. Publish a statement notifying employees that the unlawful manufacture, distribution, dispensing, possession or use of a controlled substance is prohibited in the workplace and specifying the actions that will be taken against employees for violations of such prohibition.
2. Inform employees about the dangers of drug abuse in the workplace, the business's policy of maintaining a drug-free workplace, any available drug counseling, rehabilitation, and employee assistance programs, and the penalties that may be imposed upon employees for drug abuse violations.
3. Give each employee engaged in providing the commodities or contractual services that are under contract a copy of the Drug-Free statement.
4. Notify the employees that as a condition of working on the commodities or contractual services that are under contract, employee will abide by the terms of the statement and will notify the employer of any conviction of, or plea of guilty or nolo contendere to, any violation of Chapter 893 or of any controlled substance law of the United States or any state, for a violation occurring in the workplace no later than five (5) days after such conviction.
5. Impose a sanction on, or require the satisfactory participation in a drug abuse assistance or rehabilitation program if such is available in the employee's community, by any employee who is so convicted.
6. Make a good faith effort to continue to maintain a drug-free workplace through implementation of this section.

As the person authorized to sign the statement, I certify that this business complies fully with the above requirements.

Aaron Spencer

(Authorized signature)

10/20/19

(Date)

Aaron Spencer

(Print/type name as signed above)

****THIS FORM MUST BE COMPLETED AND RETURNED WITH YOUR SUBMITTAL.**

SECTION 00900 - INSURANCE REQUIREMENTS FORM

Insurance Type	Required Limits
✓ Worker's Compensation	Statutory Limits of Florida Statutes, Chapter 440 and all Federal Government Statutory Limits
✓ Employer's Liability	\$1,000,000 each accident, single limit per occurrence
✓ Commercial General Liability (Occurrence Form) patterned after the current ISO form	\$1,000,000 single limit per occurrence \$3,000,000 aggregate for Bodily Injury Liability & Property Damage Liability. This shall include Premises and Operations; Independent Contractors; Products & Completed Operations & Contractual Liability.
✓ Indemnification	To the maximum extent permitted by Florida law, the Contractor/Vendor/Consultant shall indemnify and hold harmless City of Winter Springs, its officers and employees from any and all liabilities, damages, losses and costs, including, but not limited to, reasonable attorneys' fees and paralegals' fees, to the extent caused by the negligence, recklessness, or intentional wrongful conduct of the Contractor/Vendor/Consultant or anyone employed or utilized by the Contractor/Vendor/Consultant in the performance of the Agreement. This indemnification obligation shall not be construed to negate, abridge or reduce any other rights or remedies which otherwise may be available to an indemnified party or person described in this paragraph. This section does not pertain to any incident arising from the sole negligence of the City of Winter Springs.
✓ Automobile Liability	\$1,000,000 each person; Bodily Injury & Property Damage, Owned/Non-owned/Hired; Automobile Included.
<input type="checkbox"/> Other	

Vendor shall ensure that all subcontractors comply with the same insurance requirements that he/she is required to meet. The same Vendor shall provide the City with certificates of insurance meeting the required insurance provisions.

The City of Winter Springs must be named as **"ADDITIONAL INSURED"** on the

Insurance Certificate for Commercial General Liability where required.
The Certificate Holder shall be named as City of Winter Springs.



CERTIFICATE OF LIABILITY INSURANCE

DATE (MM/DD/YYYY)

10/22/2019

THIS CERTIFICATE IS ISSUED AS A MATTER OF INFORMATION ONLY AND CONFERS NO RIGHTS UPON THE CERTIFICATE HOLDER. THIS CERTIFICATE DOES NOT AFFIRMATIVELY OR NEGATIVELY AMEND, EXTEND OR ALTER THE COVERAGE AFFORDED BY THE POLICIES BELOW. THIS CERTIFICATE OF INSURANCE DOES NOT CONSTITUTE A CONTRACT BETWEEN THE ISSUING INSURER(S), AUTHORIZED REPRESENTATIVE OR PRODUCER, AND THE CERTIFICATE HOLDER.

IMPORTANT: If the certificate holder is an ADDITIONAL INSURED, the policy(ies) must have ADDITIONAL INSURED provisions or be endorsed. If SUBROGATION IS WAIVED, subject to the terms and conditions of the policy, certain policies may require an endorsement. A statement on this certificate does not confer rights to the certificate holder in lieu of such endorsement(s).

PRODUCER Hiscox Inc. 520 Madison Avenue 32nd Floor New York, NY 10022	CONTACT NAME: PHONE (A/C, No, Ext): (888) 202-3007		FAX (A/C, No):	
	E-MAIL ADDRESS: contact@hiscox.com			
INSURED CALIGREENLANDSCPING 1094 North Ronald Reagan Boulevard Longwood, FL 32750	INSURER(S) AFFORDING COVERAGE		NAIC #	
	INSURER A: Hiscox Insurance Company Inc		10200	
	INSURER B:			
	INSURER C:			
	INSURER D:			
	INSURER E:			
INSURER F:				

COVERAGES **CERTIFICATE NUMBER:** **REVISION NUMBER:**

THIS IS TO CERTIFY THAT THE POLICIES OF INSURANCE LISTED BELOW HAVE BEEN ISSUED TO THE INSURED NAMED ABOVE FOR THE POLICY PERIOD INDICATED. NOTWITHSTANDING ANY REQUIREMENT, TERM OR CONDITION OF ANY CONTRACT OR OTHER DOCUMENT WITH RESPECT TO WHICH THIS CERTIFICATE MAY BE ISSUED OR MAY PERTAIN, THE INSURANCE AFFORDED BY THE POLICIES DESCRIBED HEREIN IS SUBJECT TO ALL THE TERMS, EXCLUSIONS AND CONDITIONS OF SUCH POLICIES. LIMITS SHOWN MAY HAVE BEEN REDUCED BY PAID CLAIMS.

INSR LTR	TYPE OF INSURANCE	ADDL SUBR INSD WVD	POLICY NUMBER	POLICY EFF (MM/DD/YYYY)	POLICY EXP (MM/DD/YYYY)	LIMITS
A	<input checked="" type="checkbox"/> COMMERCIAL GENERAL LIABILITY <input type="checkbox"/> CLAIMS-MADE <input checked="" type="checkbox"/> OCCUR	Y	UDC-2412182-CGL-19	11/13/2019	11/13/2020	EACH OCCURRENCE \$ 1,000,000
	<input type="checkbox"/> GEN'L AGGREGATE LIMIT APPLIES PER: <input checked="" type="checkbox"/> POLICY <input type="checkbox"/> PRO-JECT <input type="checkbox"/> LOG OTHER:					DAMAGE TO RENTED PREMISES (Ea occurrence) \$ 100,000
						MED EXP (Any one person) \$ 5,000
						PERSONAL & ADV INJURY \$ 1,000,000
						GENERAL AGGREGATE \$ 2,000,000
						PRODUCTS - COM/OP AGG \$ S/T Gen. Agg
						\$
	AUTOMOBILE LIABILITY <input type="checkbox"/> ANY AUTO <input type="checkbox"/> OWNED AUTOS ONLY <input type="checkbox"/> SCHEDULED AUTOS <input type="checkbox"/> HIRED AUTOS ONLY <input type="checkbox"/> NON-OWNED AUTOS ONLY					COMBINED SINGLE LIMIT (Ea accident) \$
						BODILY INJURY (Per person) \$
						BODILY INJURY (Per accident) \$
						PROPERTY DAMAGE (Per accident) \$
						\$
	<input type="checkbox"/> UMBRELLA LIAB <input type="checkbox"/> OCCUR <input type="checkbox"/> EXCESS LIAB <input type="checkbox"/> CLAIMS-MADE <input type="checkbox"/> DED <input type="checkbox"/> RETENTION \$					EACH OCCURRENCE \$
						AGGREGATE \$
						\$
	WORKERS COMPENSATION AND EMPLOYERS' LIABILITY ANY PROPRIETOR/PARTNER/EXECUTIVE OFFICER/MEMBER EXCLUDED? (Mandatory In NH) If yes, describe under DESCRIPTION OF OPERATIONS below	Y/N	N/A			PER STATUTE
						OTHER
						E.L. EACH ACCIDENT \$
						E.L. DISEASE - EA EMPLOYEE \$
						E.L. DISEASE - POLICY LIMIT \$

DESCRIPTION OF OPERATIONS / LOCATIONS / VEHICLES (ACORD 101, Additional Remarks Schedule, may be attached if more space is required)

CERTIFICATE HOLDER

City of Winter Springs
 1126 East S.R. 434
 Winter Springs FL 32708

CANCELLATION

SHOULD ANY OF THE ABOVE DESCRIBED POLICIES BE CANCELLED BEFORE THE EXPIRATION DATE THEREOF, NOTICE WILL BE DELIVERED IN ACCORDANCE WITH THE POLICY PROVISIONS.

AUTHORIZED REPRESENTATIVE

© 1988-2015 ACORD CORPORATION. All rights reserved.



CERTIFICATE OF LIABILITY INSURANCE

DATE (MM/DD/YYYY)

08/05/2019

THIS CERTIFICATE IS ISSUED AS A MATTER OF INFORMATION ONLY AND CONFERS NO RIGHTS UPON THE CERTIFICATE HOLDER. THIS CERTIFICATE DOES NOT AFFIRMATIVELY OR NEGATIVELY AMEND, EXTEND OR ALTER THE COVERAGE AFFORDED BY THE POLICIES BELOW. THIS CERTIFICATE OF INSURANCE DOES NOT CONSTITUTE A CONTRACT BETWEEN THE ISSUING INSURER(S), AUTHORIZED REPRESENTATIVE OR PRODUCER, AND THE CERTIFICATE HOLDER.

IMPORTANT: If the certificate holder is an ADDITIONAL INSURED, the policy(ies) must be endorsed. If SUBROGATION IS WAIVED, subject to the terms and conditions of the policy, certain policies may require an endorsement. A statement on this certificate does not confer rights to the certificate holder in lieu of such endorsement(s).

PRODUCER Hiscox Inc. 520 Madison Avenue 32nd Floor New York, NY 10022		CONTACT NAME: PHONE (A/C, No, Ext): (888) 202-3007 E-MAIL ADDRESS: contact@hiscox.com FAX (A/C, No):															
INSURED CALIGREENLANDSCPING 1094 North Ronald Reagan Boulevard Longwood FL 32750		<table border="1"> <thead> <tr> <th>INSURER(S) AFFORDING COVERAGE</th> <th>NAIC #</th> </tr> </thead> <tbody> <tr> <td>INSURER A : Hiscox Insurance Company Inc</td> <td>10200</td> </tr> <tr> <td>INSURER B :</td> <td></td> </tr> <tr> <td>INSURER C :</td> <td></td> </tr> <tr> <td>INSURER D :</td> <td></td> </tr> <tr> <td>INSURER E :</td> <td></td> </tr> <tr> <td>INSURER F :</td> <td></td> </tr> </tbody> </table>		INSURER(S) AFFORDING COVERAGE	NAIC #	INSURER A : Hiscox Insurance Company Inc	10200	INSURER B :		INSURER C :		INSURER D :		INSURER E :		INSURER F :	
INSURER(S) AFFORDING COVERAGE	NAIC #																
INSURER A : Hiscox Insurance Company Inc	10200																
INSURER B :																	
INSURER C :																	
INSURER D :																	
INSURER E :																	
INSURER F :																	

COVERAGES**CERTIFICATE NUMBER:****REVISION NUMBER:**

THIS IS TO CERTIFY THAT THE POLICIES OF INSURANCE LISTED BELOW HAVE BEEN ISSUED TO THE INSURED NAMED ABOVE FOR THE POLICY PERIOD INDICATED. NOTWITHSTANDING ANY REQUIREMENT, TERM OR CONDITION OF ANY CONTRACT OR OTHER DOCUMENT WITH RESPECT TO WHICH THIS CERTIFICATE MAY BE ISSUED OR MAY PERTAIN, THE INSURANCE AFFORDED BY THE POLICIES DESCRIBED HEREIN IS SUBJECT TO ALL THE TERMS, EXCLUSIONS AND CONDITIONS OF SUCH POLICIES. LIMITS SHOWN MAY HAVE BEEN REDUCED BY PAID CLAIMS.

INSR LTR	TYPE OF INSURANCE	ADDL SUBR (INSR, WVO)	POLICY NUMBER	POLICY EFF (MM/DD/YYYY)	POLICY EXP (MM/DD/YYYY)	LIMITS
A	<input checked="" type="checkbox"/> COMMERCIAL GENERAL LIABILITY <input type="checkbox"/> CLAIMS-MADE <input checked="" type="checkbox"/> OCCUR GEN'L AGGREGATE LIMIT APPLIES PER: <input checked="" type="checkbox"/> POLICY <input type="checkbox"/> PRO-JECT <input type="checkbox"/> LOC OTHER:		UDC-2412182-CGL-18	11/13/2018	11/13/2019	EACH OCCURRENCE \$ 1,000,000 DAMAGE TO RENTED PREMISES (Ea occurrence) \$ 100,000 MED EXP (Any one person) \$ 5,000 PERSONAL & ADV INJURY \$ 1,000,000 GENERAL AGGREGATE \$ 2,000,000 PRODUCTS - COMP/OP AGG \$ S/T Gen. Agg. \$
	AUTOMOBILE LIABILITY <input type="checkbox"/> ANY AUTO <input type="checkbox"/> ALL OWNED AUTOS <input type="checkbox"/> HIRED AUTOS <input type="checkbox"/> SCHEDULED AUTOS <input type="checkbox"/> NON-OWNED AUTOS					COMBINED SINGLE LIMIT (Ea accident) \$ BODILY INJURY (Per person) \$ BODILY INJURY (Per accident) \$ PROPERTY DAMAGE (Per accident) \$ \$
	<input type="checkbox"/> UMBRELLA LIAB <input type="checkbox"/> EXCESS LIAB <input type="checkbox"/> OCCUR <input type="checkbox"/> CLAIMS-MADE <input type="checkbox"/> DED <input type="checkbox"/> RETENTION \$					EACH OCCURRENCE \$ AGGREGATE \$ \$
	WORKERS COMPENSATION AND EMPLOYERS' LIABILITY <input type="checkbox"/> ANY PROPRIETOR/PARTNER/EXECUTIVE OFFICER/MEMBER EXCLUDED? (Mandatory in NH) If yes, describe under DESCRIPTION OF OPERATIONS below	Y/N	N/A			PER STATUTE OTH-ER E.L. EACH ACCIDENT \$ E.L. DISEASE - EA EMPLOYEE \$ E.L. DISEASE - POLICY LIMIT \$

DESCRIPTION OF OPERATIONS / LOCATIONS / VEHICLES (ACORD 101, Additional Remarks Schedule, may be attached if more space is required)

CERTIFICATE HOLDER**CANCELLATION**

SHOULD ANY OF THE ABOVE DESCRIBED POLICIES BE CANCELLED BEFORE THE EXPIRATION DATE THEREOF, NOTICE WILL BE DELIVERED IN ACCORDANCE WITH THE POLICY PROVISIONS.

AUTHORIZED REPRESENTATIVE

© 1988-2014 ACORD CORPORATION. All rights reserved.

Tax Collector Scott Randolph

Local Business Tax Receipt

Orange County, Florida

3125 LAWN CARE 2018 \$30.00

EXPIRES 9/30/2019
1 EMPLOYEE

3125-1081409

TOTAL TAX \$30.00
PENALTIES \$7.50
PREVIOUSLY PAID \$37.50
TOTAL DUE \$0.00

SPENCER AARON A

CALIGREENLANDSCAPING
SPENCER AARON A
1094 RONALD REAGAN BLVD
LONGWOOD FL 32750

10406 OLGOT ST (MOBILE)
U - ORLANDO, 32817

PAID: \$37.50 0098-00877861 4/23/2019

Tax Collector Scott Randolph

Local Business Tax Receipt

Orange County, Florida

This local Business Tax Receipt is in addition to and not in lieu of any other tax required by law or municipal ordinance. Businesses are subject to regulation of zoning, health and lawful authorities. This receipt is valid from October 1 through September 30 of receipt year. Delinquent penalty is added October 1.

3125 LAWN CARE 2018 \$30.00

EXPIRES 9/30/2019
1 EMPLOYEE

3125-1081409

TOTAL TAX \$30.00
PENALTIES \$7.50
PREVIOUSLY PAID \$37.50
TOTAL DUE \$0.00



SPENCER AARON A

CALIGREENLANDSCAPING
SPENCER AARON A
1094 RONALD REAGAN BLVD
LONGWOOD FL 32750

10406 OLCOT ST (MOBILE)
U - ORLANDO, 32817

PAID: \$37.50 0098-00877861 4/23/2019

This receipt is official when validated by the Tax Collector.

Orange County Code requires this local Business Tax Receipt to be displayed conspicuously at the place of business in public view. It is subject to inspection by all duly authorized officers of the County.

**IMPORTANT
NOTICE:**

Do you have a REAL ID driver's license? You'll need one to fly, starting 10/1/20. Check your license for a star in the top right corner. If it's there, you're set. If not, you need to update your license by scheduling an appointment. Click here to learn What To Bring (<https://www.octaxcol.com/whattobring/>).



**Orange County Tax Collector
Scott Randolph**

Independently elected to serve you.

(<https://www.octaxcol.com>)



[About Scott Randolph](#) [Locations](#) [Driver's License](#) [Tag & Title](#) [SmartPass](#) [Taxes](#)

[Careers \(https://atk.octaxcol.com/atk1/\)](https://atk.octaxcol.com/atk1/) [Resources](#) [Contact Us \(https://www.octaxcol.com/contact/\)](https://www.octaxcol.com/contact/)

Business Tax Search and Payment

You are here: [Home \(https://www.octaxcol.com\)](https://www.octaxcol.com) > [Business Tax Search and Payment](#)

[Search Again \(Search.aspx\)](#)

Business Tax Receipt ID: 1081409

Location Address: 10406 OLCOT ST Mailing Address: CALIGREENLANDSCAPING

Business: OLCOT SPENCER AARON A

New Business Date: 06/21/2010 1094 RONALD REAGAN BLVD

Application Date: 06/21/2010 LONGWOOD, FL 32750

Out of Business Date:

2019 Account Number: 3125-1081409

Category Type	Display Name	Units	Tax	Exempt	Total Fees	Total Paid	Total Amt Due
3125	LAWN CARE	1	\$30.00	\$0.00	\$3.00	\$33.00	\$0.00
Total For 2019:			\$30.00	\$0.00	\$0.00	\$33.00	\$0.00

This Business Tax Receipt ID has been paid in full

Caligreen Landscaping

Aaron Spencer

BID PROPOSAL PACKAGE 3- City parks

1. Central Winds Park- 1000 Central Winds Park Dr
2. Bear Creek Nature Trail- 1555 Winter Springs Blvd
3. Winter Springs Dog Park- 900 Hicks Ave
4. Fruitwood Park- 601 Fruitwood Ave
5. Moss Park- 314 Moss Rd
6. Oak Hollow Park- 1237 Winding Chase Blvd
7. Ranchlands Park- 191 E. Tradewinds Rd
8. Sam Smith Memorial Park- 1562 Winter Springs Blvd
9. Sunshine Park- 400 N. Edgemon Ave
10. Torcaso Park- 104 N. Moss Rd
11. Trotwood Park- 1224 Trotwood Blvd
12. Winding Hollow Park- 305 Winding Hollow Blvd

Weekly Landscaping Services: (3/15 – 10/15), Bi-Weekly Landscaping Services: (10/16 – 3/14)

Services to be performed include: mowing, blowing, trimming hedges, weed-eating, edging, pruning trees, removing spanish moss, trash removal, fertilization (as directed), annual flower rotation (as requested), insect and disease control (as required), irrigation inspection and repair (monthly/as required) and other additional services, as requested.

Grass cutting height may be adjusted to maintain a turf height of between 2-½ to 3 inches for Bahia, 4 to 5 inches for St. Augustine. Grass clippings shall be removed from the turf to avoid thatch build-up.

* Edging will be performed on all walkways, curbs, and edging of pavements. This will be performed every time we come out to complete services.

* Weed-eating will be performed on all the beds and sidewalks (pavement areas).

* All trash will be picked up before the service is started.

* Blowing debris off walkways, parking lots, etc., will be performed upon completion of services.

* Trimming of hedges shall be performed, as needed, to assure a well-tailored appearance.

Caligreen Landscaping

Aaron Spencer- Owner

Been in business of 10 years

I started for working in the landscaping field in 2001 when I started working for Commercial maintenance of central Florida. I worked for that company for 10 years as a foreman. I then went to work for Lawn team for the summer when they let me go when the winter time started. That is when I decided I wanted to start my own landscaping company. I started very small pushing my push mower around the neighborhood due to not having a truck, and started getting customers. Then little by little I bought more and more equipment till I got a truck, trailer, and all the landscaping tools that I needed to expand and go further than my neighborhood. That is when my wife started to come out with me and we did the properties together. Fast-forward to this past summer to when I got the best opportunity to work for the City of Winter Springs and maintain the municipal facilities. I have started there about June till present. I have experience in sod placement, planting, mulching, trimming, clean-ups, ex. Landscaping is something that I have a lot of passion in and love doing. As of now it is myself (Aaron Spencer-owner) I have one employee Chris as of now we do all the work as we are able to complete the amount of work we currently have with the two of us. I am willing and trying to find more employees as needed.

References:

Rosemary Mora

904-330-5752

Sammy Shehata

321-282-8627

Jerry Irrigation

407-913-5528

Proposal Form



PACKAGE # 3

Respondent Name (Company): Calgreen Landscaping

Name and Title of Person Completing Form:
Aaron Spencer - Owner

	<u>PROPOSED</u> <u>COST</u>
Base Maintenance	\$ 4,060
Palm Trimming Greater than 13' OA (per tree)	\$ 75
Crepe Trimming Greater than 13' OA (per tree)	\$ 30
Irrigation Inspections	\$ 75
Mulch- Supplied and Installed (per cubic yard)	\$ 110
Fertilizer (per application)	\$ 110
Integrated Pest Management (per application)	\$ 40
PROPOSAL TOTAL	\$ 4,500

PLANT, TREE, AND GROUND COVER INSTALLATION

Not to be included as part of proposal review criteria. Price to include all components of installation including staking, watering in, and one-year warranty.

Annuals (Cost plus %)	65	%
Ground cover (Cost plus %)	50	%
Shrubs (Cost plus %)	75	%
Palms (Cost plus %)	70	%
Canopy trees (Cost plus %)	85	%
Understory trees (Cost plus %)	80	%
Sod (Cost plus %)	90	%

Proposal Form (Continued)



PACKAGE # 3

TREE REMOVAL AND STUMP GRINDING

Not to be included as part of the proposal review criteria. Price to include back fill/sod if needed.

Tree removal 6"	\$	225
Tree removal 12"	\$	500
Tree removal 18"	\$	620
Tree removal 24"	\$	720
Tree removal 36"	\$	1000

IRRIGATION REPAIR

Not to be included as part of proposal review criteria unless otherwise noted.

Wholesale price of materials plus proposed percentage		50	%
Irrigation Technician Hourly Rate	\$	17	

Signature of person completing form:

Aaron Spencer

SECTION 00700 - DRUG FREE WORKPLACE FORM

The undersigned proposer, in accordance with Florida Statute 287.087 hereby certifies that

Caligreen Landscaping does:
(Name of Business)

1. Publish a statement notifying employees that the unlawful manufacture, distribution, dispensing, possession or use of a controlled substance is prohibited in the workplace and specifying the actions that will be taken against employees for violations of such prohibition.
2. Inform employees about the dangers of drug abuse in the workplace, the business's policy of maintaining a drug-free workplace, any available drug counseling, rehabilitation, and employee assistance programs, and the penalties that may be imposed upon employees for drug abuse violations.
3. Give each employee engaged in providing the commodities or contractual services that are under contract a copy of the Drug-Free statement.
4. Notify the employees that as a condition of working on the commodities or contractual services that are under contract, employee will abide by the terms of the statement and will notify the employer of any conviction of, or plea of guilty or nolo contendere to, any violation of Chapter 893 or of any controlled substance law of the United States or any state, for a violation occurring in the workplace no later than five (5) days after such conviction.
5. Impose a sanction on, or require the satisfactory participation in a drug abuse assistance or rehabilitation program if such is available in the employee's community, by any employee who is so convicted.
6. Make a good faith effort to continue to maintain a drug-free workplace through implementation of this section.

As the person authorized to sign the statement, I certify that this business complies fully with the above requirements.

Arnon Spencer
(Authorized signature)

10/22/19
(Date)

Arnon Spencer
(Print/type name as signed above)

****THIS FORM MUST BE COMPLETED AND RETURNED WITH YOUR SUBMITTAL**

NON-COLLUSION AFFIDAVIT OF PRIME RESPONDENT

STATE OF Florida)

COUNTY OF Seminole)

Arnon Spencer, being duly sworn, deposes and says that:

(1) He/she is owner of Caligreen Landscaping,
Title Firm/Company

the respondent that has submitted the attached response.

- (2) He/she is fully informed respecting the preparation and contents of the attached solicitation and of all pertinent circumstances respecting such solicitation.
- (3) Such solicitation is genuine and is not a collusive or sham solicitation.
- (4) Neither the said respondent nor any of its officers, partners, owners, agent representatives, employees or parties in interest including this affiant, has in any way, colluded, conspired, or agreed, directly or indirectly, with any other respondent, firm or person, to submit a collusive or sham response in connection with the Agreement for which the attached response has been submitted or to refrain from proposing in connection with such Agreement, or has in any manner, directly or indirectly, sought by Agreement or collusion or communication or conference with any other responder, firm or person to fix the price or prices in the attached solicitation or of any other respondent, or to fix any overhead, profit or cost element of the proposed price or the proposed price of any other responder, or to secure through any collusion, conspiracy, connivance or unlawful Agreement any advantage against the City of Winter Springs, Florida, or any person interested in the proposed Agreement.
- (5) The price or prices quoted in the attached response are fair and proper and are not tainted by any collusion, conspiracy, or unlawful Agreement on the part of the proposer or any of its agents, representatives, owners, employees, or parties of interest, including affiant.

Arnon Spencer
(Signed)

Owner
(Title)

STATE OF FLORIDA
COUNTY OF SEMINOLE

The foregoing instrument was acknowledged before me this 10-22-2019 by Arnon A. Spencer, who is personally known to me or who has produced FL/DL 5152-001-82-028-0 as identification and who did (did not) take an oath.

[Signature] (Signature of Notary Public)

Juanita Tonia (Name of Notary Typed, Printed or Stamped)

Notar  **NOTARY PUBLIC**
STATE OF FLORIDA
Comm# GG028285 (Commission Number)

****THIS FORM MUST BE COMPLETED AND RETURNED WITH YOUR SUBMITTAL.**

Insurance Certificate for Commercial General Liability where required.
The Certificate Holder shall be named as City of Winter Springs.



CERTIFICATE OF LIABILITY INSURANCE

DATE (MM/DD/YYYY)
10/22/2019

THIS CERTIFICATE IS ISSUED AS A MATTER OF INFORMATION ONLY AND CONFERS NO RIGHTS UPON THE CERTIFICATE HOLDER. THIS CERTIFICATE DOES NOT AFFIRMATIVELY OR NEGATIVELY AMEND, EXTEND OR ALTER THE COVERAGE AFFORDED BY THE POLICIES BELOW. THIS CERTIFICATE OF INSURANCE DOES NOT CONSTITUTE A CONTRACT BETWEEN THE ISSUING INSURER(S), AUTHORIZED REPRESENTATIVE OR PRODUCER, AND THE CERTIFICATE HOLDER.

IMPORTANT: If the certificate holder is an ADDITIONAL INSURED, the policy(ies) must have ADDITIONAL INSURED provisions or be endorsed. If SUBROGATION IS WAIVED, subject to the terms and conditions of the policy, certain policies may require an endorsement. A statement on this certificate does not confer rights to the certificate holder in lieu of such endorsement(s).

PRODUCER Hiscox Inc. 520 Madison Avenue 32nd Floor New York, NY 10022	CONTACT NAME: PHONE (A/C, No., Ext): (888) 202-3007 FAX (A/C, No):	
	E-MAIL ADDRESS: contact@hiscox.com	
INSURED CALIGREENLANDSCPING 1094 North Ronald Reagan Boulevard Longwood, FL 32750	INSURER(S) AFFORDING COVERAGE	
	INSURER A: Hiscox Insurance Company Inc	NAIC # 10200
	INSURER B:	
	INSURER C:	
	INSURER D:	
	INSURER E:	

COVERAGES CERTIFICATE NUMBER: REVISION NUMBER:

THIS IS TO CERTIFY THAT THE POLICIES OF INSURANCE LISTED BELOW HAVE BEEN ISSUED TO THE INSURED NAMED ABOVE FOR THE POLICY PERIOD INDICATED. NOTWITHSTANDING ANY REQUIREMENT, TERM OR CONDITION OF ANY CONTRACT OR OTHER DOCUMENT WITH RESPECT TO WHICH THIS CERTIFICATE MAY BE ISSUED OR MAY PERTAIN, THE INSURANCE AFFORDED BY THE POLICIES DESCRIBED HEREIN IS SUBJECT TO ALL THE TERMS, EXCLUSIONS AND CONDITIONS OF SUCH POLICIES. LIMITS SHOWN MAY HAVE BEEN REDUCED BY PAID CLAIMS.

INSR LTR	TYPE OF INSURANCE	ADDL SUBR INSD WVD	POLICY NUMBER	POLICY EFF (MM/DD/YYYY)	POLICY EXP (MM/DD/YYYY)	LIMITS
A	<input checked="" type="checkbox"/> COMMERCIAL GENERAL LIABILITY <input type="checkbox"/> CLAIMS-MADE <input checked="" type="checkbox"/> OCCUR GEN'L AGGREGATE LIMIT APPLIES PER: <input checked="" type="checkbox"/> POLICY <input type="checkbox"/> PRO-JECT <input type="checkbox"/> LOC OTHER:	Y	UDC-2412182-CGL-19	11/13/2019	11/13/2020	EACH OCCURRENCE \$ 1,000,000
	DAMAGE TO RENTED PREMISES (Ea occurrence) \$ 100,000 MED EXP (Any one person) \$ 5,000 PERSONAL & ADV INJURY \$ 1,000,000 GENERAL AGGREGATE \$ 2,000,000 PRODUCTS - COM/OP AGG \$ S/T Gen. Agg					
	AUTOMOBILE LIABILITY <input type="checkbox"/> ANY AUTO <input type="checkbox"/> OWNED AUTOS ONLY <input type="checkbox"/> SCHEDULED AUTOS <input type="checkbox"/> HIRED AUTOS ONLY <input type="checkbox"/> NON-OWNED AUTOS ONLY					COMBINED SINGLE LIMIT (Ea accident) \$ BODILY INJURY (Per person) \$ BODILY INJURY (Per accident) \$ PROPERTY DAMAGE (Per accident) \$
	UMBRELLA LIAB <input type="checkbox"/> OCCUR EXCESS LIAB <input type="checkbox"/> CLAIMS-MADE DED RETENTION \$					EACH OCCURRENCE \$ AGGREGATE \$
	WORKERS COMPENSATION AND EMPLOYERS' LIABILITY ANY PROPRIETOR/PARTNER/EXECUTIVE OFFICER/MEMBER EXCLUDED? (Mandatory in NH) If yes, describe under DESCRIPTION OF OPERATIONS below	Y/N	N/A			PER STATUTE OTH-ER E.L. EACH ACCIDENT \$ E.L. DISEASE - EA EMPLOYEE \$ E.L. DISEASE - POLICY LIMIT \$

DESCRIPTION OF OPERATIONS / LOCATIONS / VEHICLES (ACORD 101, Additional Remarks Schedule, may be attached if more space is required)

CERTIFICATE HOLDER

City of Winter Springs
 1126 East S.R. 434
 Winter Springs FL 32708

CANCELLATION

SHOULD ANY OF THE ABOVE DESCRIBED POLICIES BE CANCELLED BEFORE THE EXPIRATION DATE THEREOF, NOTICE WILL BE DELIVERED IN ACCORDANCE WITH THE POLICY PROVISIONS.

AUTHORIZED REPRESENTATIVE

© 1988-2015 ACORD CORPORATION. All rights reserved.



CERTIFICATE OF LIABILITY INSURANCE

DATE (MM/DD/YYYY)

08/05/2019

THIS CERTIFICATE IS ISSUED AS A MATTER OF INFORMATION ONLY AND CONFERS NO RIGHTS UPON THE CERTIFICATE HOLDER. THIS CERTIFICATE DOES NOT AFFIRMATIVELY OR NEGATIVELY AMEND, EXTEND OR ALTER THE COVERAGE AFFORDED BY THE POLICIES BELOW. THIS CERTIFICATE OF INSURANCE DOES NOT CONSTITUTE A CONTRACT BETWEEN THE ISSUING INSURER(S), AUTHORIZED REPRESENTATIVE OR PRODUCER, AND THE CERTIFICATE HOLDER.

IMPORTANT: If the certificate holder is an ADDITIONAL INSURED, the policy(ies) must be endorsed. If SUBROGATION IS WAIVED, subject to the terms and conditions of the policy, certain policies may require an endorsement. A statement on this certificate does not confer rights to the certificate holder in lieu of such endorsement(s).

PRODUCER Hiscox Inc. 520 Madison Avenue 32nd Floor New York, NY 10022	CONTACT NAME: PHONE (A/C No. Ext): (888) 202-3007 E-MAIL ADDRESS: contact@hiscox.com	FAX (A/C No.):
	INSURER(S) AFFORDING COVERAGE	
INSURED CALIGREENLANDSCPING 1094 North Ronald Reagan Boulevard Longwood FL 32750	INSURER A: Hiscox Insurance Company Inc	NAIC # 10200
	INSURER B:	
	INSURER C:	
	INSURER D:	
	INSURER E:	

COVERAGES **CERTIFICATE NUMBER:** **REVISION NUMBER:**

THIS IS TO CERTIFY THAT THE POLICIES OF INSURANCE LISTED BELOW HAVE BEEN ISSUED TO THE INSURED NAMED ABOVE FOR THE POLICY PERIOD INDICATED. NOTWITHSTANDING ANY REQUIREMENT, TERM OR CONDITION OF ANY CONTRACT OR OTHER DOCUMENT WITH RESPECT TO WHICH THIS CERTIFICATE MAY BE ISSUED OR MAY PERTAIN, THE INSURANCE AFFORDED BY THE POLICIES DESCRIBED HEREIN IS SUBJECT TO ALL THE TERMS, EXCLUSIONS AND CONDITIONS OF SUCH POLICIES. LIMITS SHOWN MAY HAVE BEEN REDUCED BY PAID CLAIMS.

INSR LTR	TYPE OF INSURANCE	ADDL SUBR INSD WVR	POLICY NUMBER	POLICY EFF (MM/DD/YYYY)	POLICY EXP (MM/DD/YYYY)	LIMITS
A	<input checked="" type="checkbox"/> COMMERCIAL GENERAL LIABILITY <input type="checkbox"/> CLAIMS-MADE <input checked="" type="checkbox"/> OCCUR		UDC-2412182-CGL-18	11/13/2018	11/13/2019	EACH OCCURRENCE \$ 1,000,000
	GEN'L AGGREGATE LIMIT APPLIES PER: <input checked="" type="checkbox"/> POLICY <input type="checkbox"/> PRO-JECT <input type="checkbox"/> LOC OTHER:					DAMAGE TO RENTED PREMISES (Ea occurrence) \$ 100,000 MED EXP (Any one person) \$ 5,000 PERSONAL & ADV INJURY \$ 1,000,000 GENERAL AGGREGATE \$ 2,000,000 PRODUCTS - COMP/OP AGG \$ S/T Gen. Agg. \$
	AUTOMOBILE LIABILITY <input type="checkbox"/> ANY AUTO ALL OWNED AUTOS <input type="checkbox"/> HIRED AUTOS <input type="checkbox"/> SCHEDULED AUTOS NON-OWNED AUTOS					COMBINED SINGLE LIMIT (Ea accident) \$ BODILY INJURY (Per person) \$ BODILY INJURY (Per accident) \$ PROPERTY DAMAGE (Per accident) \$ \$
	<input type="checkbox"/> UMBRELLA LIAB <input type="checkbox"/> OCCUR <input type="checkbox"/> EXCESS LIAB <input type="checkbox"/> CLAIMS-MADE DED RETENTION \$					EACH OCCURRENCE \$ AGGREGATE \$ \$
	WORKERS COMPENSATION AND EMPLOYERS' LIABILITY ANY PROPRIETOR/PARTNER/EXECUTIVE OFFICER/MEMBER EXCLUDED? (Mandatory in NH) If yes, describe under DESCRIPTION OF OPERATIONS below	Y/N <input type="checkbox"/> N/A				PER STATUTE OTH-ER E.L. EACH ACCIDENT \$ E.L. DISEASE - EA EMPLOYEE \$ E.L. DISEASE - POLICY LIMIT \$

DESCRIPTION OF OPERATIONS / LOCATIONS / VEHICLES (ACORD 101, Additional Remarks Schedule, may be attached if more space is required)

CERTIFICATE HOLDER **CANCELLATION**

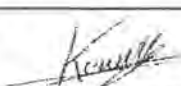
CERTIFICATE HOLDER	SHOULD ANY OF THE ABOVE DESCRIBED POLICIES BE CANCELLED BEFORE THE EXPIRATION DATE THEREOF, NOTICE WILL BE DELIVERED IN ACCORDANCE WITH THE POLICY PROVISIONS.
	AUTHORIZED REPRESENTATIVE 

© 1988-2014 ACORD CORPORATION. All rights reserved.

Tax Collector Scott Randolph

Local Business Tax Receipt

Orange County, Florida

3125 LAWN CARE 2018 \$30.00 1 EMPLOYEE EXPIRES 9/30/2019 3125-1081409

TOTAL TAX \$30.00
PENALTIES \$7.50
PREVIOUSLY PAID \$37.50
TOTAL DUE \$0.00

SPENCER AARON A

CALIGREENLANDSCAPING
SPENCER AARON A
1094 RONALD REAGAN BLVD
LONGWOOD FL 32750

10406 OLCOT ST (MOBILE)
U - ORLANDO, 32817

PAID: 537.50 0098-00877861 4/23/2019

Tax Collector Scott Randolph

Local Business Tax Receipt

Orange County, Florida

This local Business Tax Receipt is in addition to and not in lieu of any other tax required by law or municipal ordinance. Businesses are subject to regulation of zoning, health and other lawful authorities. This receipt is valid from October 1 through September 30 of receipt year. Delinquent penalty is added October 1.

3125 LAWN CARE 2018 \$30.00 1 EMPLOYEE EXPIRES 9/30/2019 3125-1081409

TOTAL TAX \$30.00
PENALTIES \$7.50
PREVIOUSLY PAID \$37.50
TOTAL DUE \$0.00



SPENCER AARON A

CALIGREENLANDSCAPING
SPENCER AARON A
1094 RONALD REAGAN BLVD
LONGWOOD FL 32750

10406 OLCOT ST (MOBILE)
U - ORLANDO, 32817

PAID: 537.50 0098-00877861 4/23/2019

This receipt is official when validated by the Tax Collector

Orange County Code requires this local Business Tax Receipt to be displayed conspicuously at the place of business in public view. It is subject to inspection by all duly authorized officers of the County

**IMPORTANT
NOTICE:**

Do you have a REAL ID driver's license? You'll need one to fly, starting 10/1/20. Check your license for a star in the top right corner. If it's there, you're set. If not, you need to update your license by scheduling an appointment. Click here to learn What To Bring (<https://www.octaxcol.com/whattobring/>).



**Orange County Tax Collector
Scott Randolph**

Independently elected to serve you.

(<https://www.octaxcol.com>)

I want to...

 (https://web.facebook.com/octaxcol_rdr)
 (https://twitter.com/octaxcol_rdr)

[About Scott Randolph](#) [Locations](#) [Driver's License](#) [Tag & Title](#) [SmartPass](#) [Taxes](#)

[Careers \(https://atk.octaxcol.com/atk1/\)](https://atk.octaxcol.com/atk1/) [Resources](#) [Contact Us \(https://www.octaxcol.com/contact/\)](https://www.octaxcol.com/contact/)

Business Tax Search and Payment

You are here: [Home \(https://www.octaxcol.com\)](https://www.octaxcol.com) > [Business Tax Search and Payment](#)

[Search Again \(Search.aspx\)](#)

Business Tax Receipt ID: 1081409

Location Address: 10406 OLCOT ST Mailing Address: CALIGREENLANDSCAPING
Business: OLCOT SPENCER AARON A
New Business Date: 06/21/2010 1094 RONALD REAGAN BLVD
Application Date: 06/21/2010 LONGWOOD, FL 32750
Out of Business Date:

2019 Account Number: 3125-1081409

Category Type	Display Name	Units	Tax	Exempt	Total Fees	Total Paid	Total Amt Due
3125	LAWN CARE	1	\$30.00	\$0.00	\$3.00	\$33.00	\$0.00
Total For 2019:			\$30.00	\$0.00	\$0.00	\$33.00	\$0.00

This Business Tax Receipt ID has been paid in full

Proposal Form



PACKAGE # #2 SR 434, MEDIANS, PONDS AND ROW'S

Respondent Name (Company): Sawnee Corp.

Name and Title of Person Completing Form: Sawnee Ferguson
President

	PROPOSED COST
Base Maintenance	\$ 154,560.00
Palm Trimming Greater than 13' OA (per tree)	\$45.00 SABAL
Crepe Trimming Greater than 13' OA (per tree)	\$ 110.00 SYLVESTER/DATE
Irrigation Inspections	\$ 110.00 EA.
Mulch- Supplied and Installed (per cubic yard)	\$ 45.00 PER HOUR
Fertilizer (per application)	\$ 60.00
Integrated Pest Management (per application)	\$14.00 per 1000 sq ft SHRUBS/TREES 6.00 " 1000 sq ft TURF
PROPOSAL TOTAL	\$ 6.00 per 1000 sq ft. \$ 154,560.00

PLANT, TREE, AND GROUND COVER INSTALLATION

Not to be included as part of proposal review criteria. Price to include all components of installation including staking, watering in, and one-year warranty.

Annuals (Cost plus %)	100 %
Ground cover (Cost plus %)	100 %
Shrubs (Cost plus %)	100 %
Palms (Cost plus %)	100 %
Canopy trees (Cost plus %)	125 %
Understory trees (Cost plus %)	125 %
Sod (Cost plus %)	125 %

Proposal Form (Continued)



PACKAGE # 2 SR484

TREE REMOVAL AND STUMP GRINDING

Not to be included as part of the proposal review criteria. Price to include back fill/sod if needed.

Tree removal 6"	\$ 102.50
Tree removal 12"	\$ 424.75
Tree removal 18"	\$ 665.25
Tree removal 24"	\$ 1464.25
Tree removal 36"	\$ 2050.00

IRRIGATION REPAIR

Not to be included as part of proposal review criteria unless otherwise noted.

Wholesale price of materials plus proposed percentage	20 %
Irrigation Technician Hourly Rate	\$ 65.00

Signature of person completing form: *Sawna Ferguson*

DAWNALEE CORPORATION

October 21, 2019

OVERVIEW

Dawnalee Corporation was formed some thirty years ago, with the sole purpose of providing personalized service and performing top quality landscape maintenance for homebuilders and homeowner associations. As our company has grown, we have diversified and are servicing many areas of maintenance clients. Dawnalee Corporation is a Winter Springs based landscape maintenance business. We are proud to have been providing the City of Winter Springs with landscape maintenance service for over 15 years. We have always made certain that our clients had easy and immediate access to our top management and that the doors of communication are always open.

It is important to recognize the Dawnalee Corporation has never invested in any type of advertising. Our entire success has been a result of referrals from our satisfied customers.

Dawnalee currently have fifteen employees with over 175 years combined experience. Dawnalee would be proud for you to contact any of our existing clients. If you have any further questions please feel free to contact either Dawna Ferguson or Robert Rushing.

Dawna Ferguson
Dawnalee Corporation
President

Dawnalee Corporation

Current or previous project experience:

City of Winter Springs
1126 East S. R. 434
Winter Springs, Florida 32708
407 327-1800 XTN 315
Previous: Grounds Maintenance of City Rights of Ways & Ponds

City of Winter Springs
1126 East S. R. 434
Winter Springs, Florida 32708
407 327-1800 XTN 315
Previous: Blumberg Boulevard Medians

City of Winter Springs
1126 East S. R. 434
Winter Springs, Florida 32708
407 327-1800 XTN 315
Current: Grounds Maintenance of SR 434

City of Oviedo
400 Alexandria Blvd.
Oviedo, Florida 32765
407 977-6069
Mr. Chris Wenner
Previous: Grounds Maintenance of , Medians
Water Treatment Facilities and Well Fields

MI Homes, Inc
300 Colonial Center Pkwy
Suite 200
Lake Mary, Florida 32746
407 531-5100
Mr. David Sellars
Purchasing
Currently: All Model & Inventory Homes Maintenance
In Central Florida

DAWNALEE CORPORATION

DAWNALEE Corporation General Information

DAWNALEE Corporation
216 Stoner Road
Winter Springs, Florida 32708
Office: (407) 696-7343
EMAIL: dawna@dawnalee.com

DAWNALEE TAX ID #59-2935428

STATE UCC REGISTRATION NO# 2038732

OCCUPATIONAL LICENSE NO# 0303339

WORKMEN'S COMPENSATION - FUBA INSURANCE CO NO# 10168

GENERAL LIABILITY INSURANCE - AUTO OWNERS INSURANCE CO. NO# 924682

AUTOMOBILE INSURANCE - STATE FARM INSURANCE CO. VARIOUS AUTO

CONTACTS:

Dawna Ferguson President
407 696-7343

Robert Rushing
407 341-8412

SECTION 00700 – DRUG FREE WORKPLACE FORM

The undersigned proposer, in accordance with Florida Statute 287.087 hereby certifies that

Southern Corporation does:

(Name of Business)

1. Publish a statement notifying employees that the unlawful manufacture, distribution, dispensing, possession or use of a controlled substance is prohibited in the workplace and specifying the actions that will be taken against employees for violations of such prohibition.
2. Inform employees about the dangers of drug abuse in the workplace, the business's policy of maintaining a drug-free workplace, any available drug counseling, rehabilitation, and employee assistance programs, and the penalties that may be imposed upon employees for drug abuse violations.
3. Give each employee engaged in providing the commodities or contractual services that are under contract a copy of the Drug-Free statement.
4. Notify the employees that as a condition of working on the commodities or contractual services that are under contract, employee will abide by the terms of the statement and will notify the employer of any conviction of, or plea of guilty or nolo contendere to, any violation of Chapter 893 or of any controlled substance law of the United States or any state, for a violation occurring in the workplace no later than five (5) days after such conviction.
5. Impose a sanction on, or require the satisfactory participation in a drug abuse assistance or rehabilitation program if such is available in the employee's community, by any employee who is so convicted.
6. Make a good faith effort to continue to maintain a drug-free workplace through implementation of this section.

As the person authorized to sign the statement, I certify that this business complies fully with the above requirements.

Dawna Ferguson

(Authorized signature)

10/21/19

(Date)

DAWNA FERGUSON

(Print/type name as signed above)

****THIS FORM MUST BE COMPLETED AND RETURNED WITH YOUR SUBMITTAL.**

NON-COLLUSION AFFIDAVIT OF PRIME RESPONDENT

STATE OF Florida)

COUNTY OF Seminole)

Dawna Ferguson, being duly sworn, deposes and says that:

(1) He/she is President of Naumalee Corporation
Title Firm/Company

the respondent that has submitted the attached response.

(2) He/she is fully informed respecting the preparation and contents of the attached solicitation and of all pertinent circumstances respecting such solicitation.

(3) Such solicitation is genuine and is not a collusive or sham solicitation.

(4) Neither the said respondent nor any of its officers, partners, owners, agent representatives, employees or parties in interest including this affiant, has in any way, colluded, conspired, or agreed, directly or indirectly, with any other respondent, firm or person, to submit a collusive or sham response in connection with the Agreement for which the attached response has been submitted or to refrain from proposing in connection with such Agreement, or has in any manner, directly or indirectly, sought by Agreement or collusion or communication or conference with any other responder, firm or person to fix the price or prices in the attached solicitation or of any other respondent, or to fix any overhead, profit or cost element of the proposed price or the proposed price of any other responder, or to secure through any collusion, conspiracy, connivance or unlawful Agreement any advantage against the City of Winter Springs, Florida, or any person interested in the proposed Agreement.

(5) The price or prices quoted in the attached response are fair and proper and are not tainted by any collusion, conspiracy, or unlawful Agreement on the part of the proposer or any of its agents, representatives, owners, employees, or parties of interest, including affiant

Dawna Ferguson

(Signed) President

(Title)

STATE OF FLORIDA

COUNTY OF SEMINOLE

The foregoing instrument was acknowledged before me this 10/21/19 by DAWNA FERGUSON who is personally known to me or who has produced FL DC as identification and who did (did not) take an oath.

[Signature] (Signature of Notary Public)

EDWIN ADAMES (Name of Notary Typed, Printed or Stamped)

Notary Public 33 4856 (Commission Number)

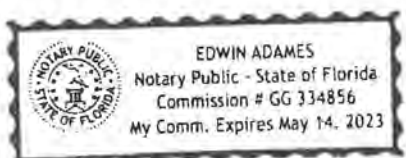

****THIS FORM MUST BE COMPLETED AND RETURNED WITH YOUR SUBMITTAL.**

6037V - CERTIFICATE OF AUTOMOBILE LIABILITY INSURANCE

36064-2-F - 2 F
Agent 2026
AFO AE9

This certificate is issued for informational purposes only. It does not change the provisions of the policy shown below.
State Farm Mutual Automobile Insurance Company, of Bloomington, Illinois certifies that liability coverage is in effect for the Named Insured and vehicle(s) as shown below:

Name and Address of Insured:

DAWNALEE CORP
216 STONER RD
WINTER SPGS FL 32708-3122

Policy Number: P24 8567-A22-59M

Effective Date of Policy: JUL 16 2019

Vehicle(s) Insured:

2014 CHEVROLET 3GCPCPEC5EG470996

LIABILITY COVERAGE

Bodily Injury and Property Damage \$1000000 Each Accident (Single Limit)

Name and Address of Certificate Holder

CITY OF WINTER SPRINGS
1126 EAST SR 434
WINTER SPGS FL 32708-2799

Name and Address of Agent

FRED FRANZ
PO BOX 621046
OVIEDO, FL 32762-1046

CANCELLATION - If the policy shown above is cancelled or otherwise terminated, State Farm Mutual Automobile Insurance Company will endeavor to mail or deliver 10 days prior written notice to the Certificate Holder. State Farm Mutual Automobile Insurance Company, its agents and representatives shall not be liable for any failure to mail or deliver such notice.

6037V

157-6037V Rev. 08-16-2006 (01a0973b)

Effective: 10/1/2019

Expiration: 9/30/2020

**CITY OF WINTER SPRINGS
BUSINESS TAX RECEIPT**

Business ID: 10233
HOME BASED NON-REGULATED

DAWNALEE CORPORATION
216 STONER RD

DESCRIPTION OF BUSINESS ACTIVITIES

LAWN MAINTENANCE

Incorporated
1959

1126 East State Road 434 • Winter Springs, FL 32708 • (407) 327-1800
www.winterspringsfl.org

BUSINESS TAX RECEIPT INCLUDES WINTER SPRINGS & SEMINOLE COUNTY TAX

PLEASE CUT ALONG THE DOTTED LINE TO DISPLAY RECEIPT IN BUSINESS

Post the above Receipt in a Conspicuous Location within your Place of Business

Total Amount Paid: \$55.00

Note: Total Amount Paid includes the \$25 Seminole County Business Tax



City Manager

DAWNALEE CORPORATION
216 STONER RD
WINTER SPRINGS, FL 32708



1126 East State Road 434
Winter Springs, FL 32708
Phone: (407) 327-1800

DAWNALEE CORPORATION

DAWNALEE Corporation Reference List

City of Winter Springs
1126 East S. R. 434
Winter Springs, Florida 32708
407 327-1800 XTN 315
Mr. Kevin Maddox

City of Oviedo
400 Alexandria Blvd.
Oviedo, Florida 32765
407 977-6069
Mr. Chris Wenner

MI Homes, Inc.
300 Colonial Center Pkwy
Suite 200
Lake Mary, Florida 32746
407 531-5100
Mr. David Sellars
Purchasing

Central Florida Communities, Inc
1890 State Road 436
Suite 300
Winter Park, Florida 32792
(407) 645-3211
Randy Stowell
Howell Branch Court Facility

CITY OF WINTER SPRINGS REQUEST FOR PROPOSAL LANDSCAPE
MAINTENANCE SERVICES

RFP 07-19

COMPLETED CHECK LIST OF REQUIRED DOCUMENTS

- X COMPANY INFORMATION
- X COMPLETED PROPOSAL FORMS FOR EACH PACKAGE
- X DRUG FREE WORKPLACE FORM
- X NON COLLUSION AFFIDAVIT
- X CERTIFICATE OF INSURANCE
- HOLD HARMLESS AGREEMENT
- X REFERENCES - At least three professional references
- X COMPLETED CHECK LIST OF REQUIRED DOCUMENTS



RFP 07-19 KM
Addendum I

Clarification of Basis of Award

The City anticipates award to the Respondent who submits the Proposals judged by the City to be the most advantageous. The City anticipates awarding Agreements to the highest ranked Respondent, but reserves the right to award more or fewer Agreements if it is in the best interest of the City. The City reserves the right to assign work or task orders to various Respondents based on pricing submitted. The City reserves the right to pick and choose Respondent based on ranking. The City reserves the right to enter into the Agreements negotiations with the highest ranked Respondent(s). If the City and any of these Respondent(s) cannot negotiate a successful Agreement, the City may terminate such negotiation(s) and begin negotiation(s) with the next highest ranked Respondent(s). No Respondent shall have any rights against the City arising from such negotiations.

Clarification for Package #5 Tuskawilla Rd, Tuskawilla Lighting and Beautification District, and the Oak Forest Assessment District

1. Location iii Tuscawilla Lighting and Beautification District. Maintenance of this location includes Winter Springs Blvd, east of Tuskawilla Rd, and the North and South fountain entrances into Tuscawilla (at the intersection on Winter Springs Blvd. and Tuskawilla Rd). Disregard subsection (a).

Clarification for Package #6 N. Tuskawilla Rd, Blumberg Blvd, and Market Square

1. Location i Blumberg Blvd. Maintenance of this location is for the Center Median Gardens and Monuments on Blumberg Blvd. Disregard subsection (a).
2. Location ii N. Tuskawilla Rd . Maintenance of this location is for N. Tuskawilla Rd from SR 434 to 100' North of Blumberg Blvd. Disregard subsection (a).

Update to Calendar of Events

The calendar of events has been updated to reflect the cancellation of the October 28, 2019 Commission Meeting. Please see below.

Request for Proposals Advertised	October 4, 2019
Technical Questions Due to the City (written)	October 13, 2019 @ 11:59 PM
Responses to Questions Due from the City	October 14, 2019
Proposals Due to the City	October 23, 2019 @ 10:00 AM
Commission Approval of Qualified Vendor	November 18, 2019
Contract Negotiations	November 19- November 27
Effective Date of Landscaping Services	The week of December 1, 2019

Proposal Form



PACKAGE # 3 CITY PARKS

Respondent Name (Company): Savonice Corp.

Name and Title of Person Completing Form: Savonice Furquison
President

PROPOSED COST

Base Maintenance	\$ 128,264.00
Palm Trimming Greater than 13' OA (per tree)	\$45.00 SABAL \$110.00 SYLVESTR/DATE
Crepe Trimming Greater than 13' OA (per tree)	\$ 110.00 EA.
Irrigation Inspections	\$ 45.00 PER HOUR
Mulch- Supplied and Installed (per cubic yard)	\$ 60.00
Fertilizer (per application)	\$14.00 per 1000sq ft TREE / SHRUB 6.00 per 1000sq ft TURF
Integrated Pest Management (per application)	\$ 6.00 per 1000sq ft.
PROPOSAL TOTAL	\$ 128,264.00

PLANT, TREE, AND GROUND COVER INSTALLATION

Not to be included as part of proposal review criteria. Price to include all components of installation including staking, watering in, and one-year warranty.

Annuals (Cost plus %)	100 %
Ground cover (Cost plus %)	100 %
Shrubs (Cost plus %)	100 %
Palms (Cost plus %)	125 %
Canopy trees (Cost plus %)	125 %
Understory trees (Cost plus %)	125 %
Sod (Cost plus %)	125 %

Proposal Form (Continued)



PACKAGE # 3 CITY PARKS

TREE REMOVAL AND STUMP GRINDING

Not to be included as part of the proposal review criteria. Price to include back fill/sod if needed.

Tree removal 6"	\$ 102.50
Tree removal 12"	\$ 424.75
Tree removal 18"	\$ 665.25
Tree removal 24"	\$ 1464.25
Tree removal 36"	\$ 2050.00

IRRIGATION REPAIR

Not to be included as part of proposal review criteria unless otherwise noted.

Wholesale price of materials plus proposed percentage	20 %
Irrigation Technician Hourly Rate	\$65.00

Signature of person completing form: *Naomi Ferguson*

DAWNALEE CORPORATION

October 21, 2019

OVERVIEW

Dawnalee Corporation was formed some thirty years ago, with the sole purpose of providing personalized service and performing top quality landscape maintenance for homebuilders and homeowner associations. As our company has grown, we have diversified and are servicing many areas of maintenance clients. Dawnalee Corporation is a Winter Springs based landscape maintenance business. We are proud to have been providing the City of Winter Springs with landscape maintenance service for over 15 years. We have always made certain that our clients had easy and immediate access to our top management and that the doors of communication are always open.

It is important to recognize the Dawnalee Corporation has never invested in any type of advertising. Our entire success has been a result of referrals from our satisfied customers.

Dawnalee currently have fifteen employees with over 175 years combined experience. Dawnalee would be proud for you to contact any of our existing clients. If you have any further questions please feel free to contact either Dawna Ferguson or Robert Rushing.

Dawna Ferguson
Dawnalee Corporation
President

Dawnalee Corporation

Current or previous project experience:

City of Winter Springs
1126 East S. R. 434
Winter Springs, Florida 32708
407 327-1800 XTN 315

Previous: Grounds Maintenance of City Rights of Ways & Ponds

City of Winter Springs
1126 East S. R. 434
Winter Springs, Florida 32708
407 327-1800 XTN 315

Previous: Blumberg Boulevard Medians

City of Winter Springs
1126 East S. R. 434
Winter Springs, Florida 32708
407 327-1800 XTN 315

Current: Grounds Maintenance of SR 434

City of Oviedo
400 Alexandria Blvd.
Oviedo, Florida 32765
407 977-6069

Mr. Chris Wenner

Previous: Grounds Maintenance of , Medians
Water Treatment Facilities and Well Fields

MI Homes, Inc
300 Colonial Center Pkwy
Suite 200
Lake Mary, Florida 32746
407 531-5100

Mr. David Sellars

Purchasing

Currently: All Model & Inventory Homes Maintenance
In Central Florida

DAWNALEE CORPORATION

DAWNALEE Corporation General Information

DAWNALEE Corporation
216 Stoner Road
Winter Springs, Florida 32708
Office: (407) 696-7343
EMAIL: dawna@dawnalee.com

DAWNALEE TAX ID #59-2935428

STATE UCC REGISTRATION NO# 2038732

OCCUPATIONAL LICENSE NO# 0303339

WORKMEN'S COMPENSATION - FUBA INSURANCE CO NO# 10168

GENERAL LIABILITY INSURANCE - AUTO OWNERS INSURANCE CO. NO# 924682

AUTOMOBILE INSURANCE - STATE FARM INSURANCE CO. VARIOUS AUTO

CONTACTS:

Dawna Ferguson President
407 696-7343

Robert Rushing
407 341-8412

SECTION 00700 – DRUG FREE WORKPLACE FORM

The undersigned proposer, in accordance with Florida Statute 287.087 hereby certifies that

Sawnee Corporation does:

(Name of Business)

1. Publish a statement notifying employees that the unlawful manufacture, distribution, dispensing, possession or use of a controlled substance is prohibited in the workplace and specifying the actions that will be taken against employees for violations of such prohibition.
2. Inform employees about the dangers of drug abuse in the workplace, the business's policy of maintaining a drug-free workplace, any available drug counseling, rehabilitation, and employee assistance programs, and the penalties that may be imposed upon employees for drug abuse violations.
3. Give each employee engaged in providing the commodities or contractual services that are under contract a copy of the Drug-Free statement.
4. Notify the employees that as a condition of working on the commodities or contractual services that are under contract, employee will abide by the terms of the statement and will notify the employer of any conviction of, or plea of guilty or nolo contendere to, any violation of Chapter 893 or of any controlled substance law of the United States or any state, for a violation occurring in the workplace no later than five (5) days after such conviction.
5. Impose a sanction on, or require the satisfactory participation in a drug abuse assistance or rehabilitation program if such is available in the employee's community, by any employee who is so convicted.
6. Make a good faith effort to continue to maintain a drug-free workplace through implementation of this section.

As the person authorized to sign the statement, I certify that this business complies fully with the above requirements.

Sawna Ferguson

(Authorized signature)

10/21/19

(Date)

SAWNA FERGUSON

(Print/type name as signed above)

****THIS FORM MUST BE COMPLETED AND RETURNED WITH YOUR SUBMITTAL.**

NON-COLLUSION AFFIDAVIT OF PRIME RESPONDENT

STATE OF Florida)

COUNTY OF Seminole)

Dawna Ferguson being duly sworn, deposes and says that:

(1) He/she is President of Lawrence Corporation
Title Firm/Company

the respondent that has submitted the attached response.

- (2) He/she is fully informed respecting the preparation and contents of the attached solicitation and of all pertinent circumstances respecting such solicitation.
- (3) Such solicitation is genuine and is not a collusive or sham solicitation.
- (4) Neither the said respondent nor any of its officers, partners, owners, agent representatives, employees or parties in interest including this affiant, has in any way, colluded, conspired, or agreed, directly or indirectly, with any other respondent, firm or person, to submit a collusive or sham response in connection with the Agreement for which the attached response has been submitted or to refrain from proposing in connection with such Agreement, or has in any manner, directly or indirectly, sought by Agreement or collusion or communication or conference with any other responder, firm or person to fix the price or prices in the attached solicitation or of any other respondent, or to fix any overhead, profit or cost element of the proposed price or the proposed price of any other responder, or to secure through any collusion, conspiracy, connivance or unlawful Agreement any advantage against the City of Winter Springs, Florida, or any person interested in the proposed Agreement.
- (5) The price or prices quoted in the attached response are fair and proper and are not tainted by any collusion, conspiracy, or unlawful Agreement on the part of the proposer or any of its agents, representatives, owners, employees, or parties of interest, including affiant.

Dawna Ferguson

(Signed)
President

(Title)

STATE OF FLORIDA

COUNTY OF SEMINOLE

The foregoing instrument was acknowledged before me this 10/21/19 by DAWNA FERGUSON who is personally known to me or who has produced FL DL as identification and who did (did not) take an oath.

[Signature] (Signature of Notary Public)

EDWIN ADAMES (Name of Notary Typed, Printed or Stamped)

Notary Public
GG 33 4856 (Commission Number)

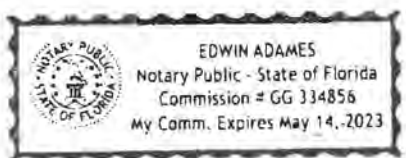

****THIS FORM MUST BE COMPLETED AND RETURNED WITH YOUR SUBMITTAL.**

Client#: 10598

DAWNALEE

ACORD™

CERTIFICATE OF LIABILITY INSURANCE

DATE (MM/DD/YYYY) 1/03/2019

THIS CERTIFICATE IS ISSUED AS A MATTER OF INFORMATION ONLY AND CONFERS NO RIGHTS UPON THE CERTIFICATE HOLDER. THIS CERTIFICATE DOES NOT AFFIRMATIVELY OR NEGATIVELY AMEND, EXTEND OR ALTER THE COVERAGE AFFORDED BY THE POLICIES BELOW. THIS CERTIFICATE OF INSURANCE DOES NOT CONSTITUTE A CONTRACT BETWEEN THE ISSUING INSURER(S), AUTHORIZED REPRESENTATIVE OR PRODUCER, AND THE CERTIFICATE HOLDER.

IMPORTANT: If the certificate holder is an ADDITIONAL INSURED, the policy(ies) must have ADDITIONAL INSURED provisions or be endorsed. If SUBROGATION IS WAIVED, subject to the terms and conditions of the policy, certain policies may require an endorsement. A statement on this certificate does not confer any rights to the certificate holder in lieu of such endorsement(s).

PRODUCER: Bouchard Insurance (KIS), 222 Church Street, Kissimmee, FL 34741, 407 847-2841. CONTACT NAME: [blank], PHONE (A/C, No, Ext): 407 847-2841, FAX (A/C, No): 407 846-2841, E-MAIL ADDRESS: clcert@bouchardinsurance.com. INSURER(S) AFFORDING COVERAGE: INSURER A: Southern Owners Insurance Co (NAIC # 10190), INSURER B: Lancer Indemnity Co, INSURER C: [blank], INSURER D: [blank], INSURER E: [blank], INSURER F: [blank].

COVERAGES CERTIFICATE NUMBER: REVISION NUMBER:

THIS IS TO CERTIFY THAT THE POLICIES OF INSURANCE LISTED BELOW HAVE BEEN ISSUED TO THE INSURED NAMED ABOVE FOR THE POLICY PERIOD INDICATED. NOTWITHSTANDING ANY REQUIREMENT, TERM OR CONDITION OF ANY CONTRACT OR OTHER DOCUMENT WITH RESPECT TO WHICH THIS CERTIFICATE MAY BE ISSUED OR MAY PERTAIN, THE INSURANCE AFFORDED BY THE POLICIES DESCRIBED HEREIN IS SUBJECT TO ALL THE TERMS, EXCLUSIONS AND CONDITIONS OF SUCH POLICIES. LIMITS SHOWN MAY HAVE BEEN REDUCED BY PAID CLAIMS.

Table with columns: INSR LTR, TYPE OF INSURANCE, ADDL SUBR INSR WVD, POLICY NUMBER, POLICY EFF (MM/DD/YYYY), POLICY EXP (MM/DD/YYYY), LIMITS. Includes rows for Commercial General Liability (Policy # 72075286) and Workers Compensation and Employers' Liability (Policy # 10168).

DESCRIPTION OF OPERATIONS / LOCATIONS / VEHICLES (ACORD 101, Additional Remarks Schedule, may be attached if more space is required) Waiver of subrogation applies in favor of certificate holder as respects Workers Comp only if required by written contract, and subject to the terms, conditions and exclusions as specified in the policy.

CERTIFICATE HOLDER: City of Winter Springs, 1126 SR 434, Winter Springs, FL 32708. CANCELLATION: SHOULD ANY OF THE ABOVE DESCRIBED POLICIES BE CANCELLED BEFORE THE EXPIRATION DATE THEREOF, NOTICE WILL BE DELIVERED IN ACCORDANCE WITH THE POLICY PROVISIONS. AUTHORIZED REPRESENTATIVE: [Signature]

© 1988-2015 ACORD CORPORATION. All rights reserved.

6037V - CERTIFICATE OF AUTOMOBILE LIABILITY INSURANCE

36064-2-F - 2 F
Agent 2026
AFO AE9

This certificate is issued for informational purposes only. It does not change the provisions of the policy shown below.
State Farm Mutual Automobile Insurance Company, of Bloomington, Illinois certifies that liability coverage is in effect for the Named Insured and vehicle(s) as shown below:

Name and Address of Insured:

DAWNALEE CORP
216 STONER RD
WINTER SPGS FL 32708-3122

Policy Number: P24 8567-A22-59M

Effective Date of Policy: JUL 16 2019

Vehicle(s) Insured:

2014 CHEVROLET 3GCPCEC5EG470996

LIABILITY COVERAGE

Bodily Injury and Property Damage \$1000000 Each Accident (Single Limit)

Name and Address of Certificate Holder

CITY OF WINTER SPRINGS
1126 EAST SR 434
WINTER SPGS FL 32708-2799

Name and Address of Agent

FRED FRANZ
PO BOX 621046
OVIEDO, FL 32762-1046

CANCELLATION - If the policy shown above is cancelled or otherwise terminated, State Farm Mutual Automobile Insurance Company will endeavor to mail or deliver 10 days prior written notice to the Certificate Holder. State Farm Mutual Automobile Insurance Company, its agents and representatives shall not be liable for any failure to mail or deliver such notice.

6037V

157 6037V Rev. 08-16-2006 (01a0573b)

Thirty (30) days cancellation notice required.

The undersigned firm agrees to obtain, prior to award, if selected, insurance as stated above.

Sawna Corp.

PROPOSER/BIDDER

Sawna Ferguson

AUTHORIZED SIGNATURE

President

OFFICER TITLE

10/21/2019

DATE

****THIS FORM MUST BE COMPLETED AND RETURNED WITH YOUR SUBMITTAL.**

Effective: 10/1/2019

Expiration: 9/30/2020

**CITY OF WINTER SPRINGS
BUSINESS TAX RECEIPT**

Business ID: 10233
HOME BASED NON-REGULATED

DAWNALEE CORPORATION
216 STONER RD

DESCRIPTION OF BUSINESS ACTIVITIES
LAWN MAINTENANCE

Incorporated
1959

1126 East State Road 434 • Winter Springs, FL 32708 • (407) 327-1800
www.winterspringsfl.org

BUSINESS TAX RECEIPT INCLUDES WINTER SPRINGS & SEMINOLE COUNTY TAX

PLEASE CUT ALONG THE DOTTED LINE TO DISPLAY RECEIPT IN BUSINESS

Post the above Receipt in a Conspicuous Location within your Place of Business

Total Amount Paid: \$55.00

Note: Total Amount Paid includes the \$25 Seminole County Business Tax



City Manager

DAWNALEE CORPORATION
216 STONER RD
WINTER SPRINGS, FL 32708



1126 East State Road 434
Winter Springs, FL 32708
Phone: (407) 327-1800

DAWNALEE CORPORATION

DAWNALEE Corporation Reference List

City of Winter Springs
1126 East S. R. 434
Winter Springs, Florida 32708
407 327-1800 XTN 315
Mr. Kevin Maddox

City of Oviedo
400 Alexandria Blvd.
Oviedo, Florida 32765
407 977-6069
Mr. Chris Wenner

MI Homes, Inc.
300 Colonial Center Pkwy
Suite 200
Lake Mary, Florida 32746
407 531-5100
Mr. David Sellars
Purchasing

Central Florida Communities, Inc
1890 State Road 436
Suite 300
Winter Park, Florida 32792
(407) 645-3211
Randy Stowell
Howell Branch Court Facility

CITY OF WINTER SPRINGS REQUEST FOR PROPOSAL LANDSCAPE
MAINTENANCE SERVICES

RFP 07-19

COMPLETED CHECK LIST OF REQUIRED DOCUMENTS

- X COMPANY INFORMATION
- X COMPLETED PROPOSAL FORMS FOR EACH PACKAGE
- X DRUG FREE WORKPLACE FORM
- X NON COLLUSION AFFIDAVIT
- X CERTIFICATE OF INSURANCE
- HOLD HARMLESS AGREEMENT
- X REFERENCES - At least three professional references
- X COMPLETED CHECK LIST OF REQUIRED DOCUMENTS



RFP 07-19 KM
Addendum 2 (9 pages)

Maps for Central Winds Park

Please see the below map for Central Winds Park. Please notice that only the common areas are to be included in this proposal; the athletic fields are not part of this contract.



- | | | |
|-----------------|-------------------------------------|--|
| 1. Dog Park | 4. Amphitheater | 7. Central Winds Parkway & Orange Avenue |
| 2. Lower Fields | 5. Baseball and Soccer Parking Lots | 8. Upper Fields |
| 3. Passive Area | 6. Front Entrance | |

Contract Length

The length of the contract will be two-years *with the possibility* of three (3) one-year extensions.

Site Visits

Site visits for the packages are not planned. To view the areas and provide more information for proposal formulation, use of Google Earth or other satellite imaging software is suggested.

Turf Species Frequencies

Mowing should be 40-42x per year for all species of turf.

Minor Irrigation Repairs

Minor irrigation repairs are not included and all repairs over \$50 need to be ~~proposed~~ preapproved prior to repair.

Spanish Moss Removal

Spanish moss will be removed by the request of the City.

Fig Vines- Oak Forest Wall

The fig vines will be trimmed twice per month during the growing season and once per month during the dormant season.

Location elaboration

The senior center should be included in the Sunshine Park proposal.

The road coming off of SR 434 to the West Wastewater Treatment Facility is not included in the proposal. Below is the property area for this location.





RFP 07-19 KM
Addendum 1

Clarification of Basis of Award

The City anticipates award to the Respondent who submits the Proposals judged by the City to be the most advantageous. The City anticipates awarding Agreements to the highest ranked Respondent, but reserves the right to award more or fewer Agreements if it is in the best interest of the City. The City reserves the right to assign work or task orders to various Respondents based on pricing submitted. The City reserves the right to pick and choose Respondent based on ranking. The City reserves the right to enter into the Agreements negotiations with the highest ranked Respondent(s). If the City and any of these Respondent(s) cannot negotiate a successful Agreement, the City may terminate such negotiation(s) and begin negotiation(s) with the next highest ranked Respondent(s). No Respondent shall have any rights against the City arising from such negotiations.

Clarification for Package #5 Tuskawilla Rd, Tuskawilla Lighting and Beautification District, and the Oak Forest Assessment District

1. Location iii Tuskawilla Lighting and Beautification District. Maintenance of this location includes Winter Springs Blvd, east of Tuskawilla Rd, and the North and South fountain entrances into Tuskawilla (at the intersection on Winter Springs Blvd. and Tuskawilla Rd). Disregard subsection (a).

Clarification for Package #6 N. Tuskawilla Rd, Blumberg Blvd, and Market Square

1. Location i Blumberg Blvd. Maintenance of this location is for the Center Median Gardens and Monuments on Blumberg Blvd. Disregard subsection (a).
2. Location ii N. Tuskawilla Rd . Maintenance of this location is for N. Tuskawilla Rd from SR 434 to 100' North of Blumberg Blvd. Disregard subsection (a).

Update to Calendar of Events

The calendar of events has been updated to reflect the cancellation of the October 28, 2019 Commission Meeting. Please see below.

Request for Proposals Advertised	October 4, 2019
Technical Questions Due to the City (written)	October 13, 2019 @ 11:59 PM
Responses to Questions Due from the City	October 14, 2019
Proposals Due to the City	October 23, 2019 @ 10:00 AM
Commission Approval of Qualified Vendor	November 18, 2019
Contract Negotiations	November 19- November 27
Effective Date of Landscaping Services	The week of December 1, 2019

Proposal Form



PACKAGE # #11 CROSS SEMINOLE TRAIL

Respondent Name (Company): Lawnlee Corporation

Name and Title of Person Completing Form: Dawn Ferguson
President

PROPOSED COST

Base Maintenance	\$ 43,140.00
Palm Trimming Greater than 13' OA (per tree)	\$ 45.00 SABAL 1500 SYLVESTER / DATE
Crepe Trimming Greater than 13' OA (per tree)	\$ 110.00 EA.
Irrigation Inspections	\$ 45.00 PER HOUR
Mulch- Supplied and Installed (per cubic yard)	\$ 60.00
Fertilizer (per application)	\$ 14.00 per 1000 sq ft trees 600 per 1000 " " TURF
Integrated Pest Management (per application)	\$ 6.00 per 1000 sq ft
PROPOSAL TOTAL	\$ 43,140.00

SHRUBS

PLANT, TREE, AND GROUND COVER INSTALLATION

Not to be included as part of proposal review criteria. Price to include all components of installation including staking, watering in, and one-year warranty.

Annuals (Cost plus %)	100	%
Ground cover (Cost plus %)	100	%
Shrubs (Cost plus %)	100	%
Palms (Cost plus %)	125	%
Canopy trees (Cost plus %)	125	%
Understory trees (Cost plus %)	125	%
Sod (Cost plus %)	125	%

Proposal Form (Continued)



PACKAGE # #4 CROSS SEMINOLE TRAIL

TREE REMOVAL AND STUMP GRINDING

Not to be included as part of the proposal review criteria. Price to include back fill/sod if needed.

Tree removal 6"	\$ 102.50
Tree removal 12"	\$ 424.75
Tree removal 18"	\$ 665.25
Tree removal 24"	\$ 1464.25
Tree removal 36"	\$ 2050.00

IRRIGATION REPAIR

Not to be included as part of proposal review criteria unless otherwise noted.

Wholesale price of materials plus proposed percentage	20 %
Irrigation Technician Hourly Rate	\$ 65.00

Signature of person completing form: *Savona Ferguson*

DAWNALEE CORPORATION

October 21, 2019

OVERVIEW

Dawnalee Corporation was formed some thirty years ago , with the sole purpose of providing personalized service and performing top quality landscape maintenance for homebuilders and homeowner associations. As our company has grown, we have diversified and are servicing many areas of maintenance clients. Dawnalee Corporation is a Winter Springs based landscape maintenance business. We are proud to have been providing the City of Winter Springs with landscape maintenance service for over 15 years. We have always made certain that our clients had easy and immediate access to our top management and that the doors of communication are always open.

It is important to recognize the Dawnalee Corporation has never invested in any type of advertising. Our entire success has been a result of referrals from our satisfied customers.

Dawnalee currently have fifteen employees with over 175 years combined experience. Dawnalee would be proud for you to contact any of our existing clients. If you have any further questions please feel free to contact either Dawna Ferguson or Robert Rushing.

Dawna Ferguson
Dawnalee Corporation
President

DAWNALEE CORPORATION

DAWNALEE Corporation General Information

DAWNALEE Corporation
216 Stoner Road
Winter Springs, Florida 32708
Office: (407) 696-7343
EMAIL: dawna@dawnalee.com

DAWNALEE TAX ID #59-2935428

STATE UCC REGISTRATION NO# 2038732

OCCUPATIONAL LICENSE NO# 0303339

WORKMEN'S COMPENSATION - FUBA INSURANCE CO NO# 10168

GENERAL LIABILITY INSURANCE - AUTO OWNERS INSURANCE CO. NO# 924682

AUTOMOBILE INSURANCE - STATE FARM INSURANCE CO. VARIOUS AUTO

CONTACTS:

Dawna Ferguson President
407 696-7343

Robert Rushing
407 341-8412

SECTION 00700 – DRUG FREE WORKPLACE FORM

The undersigned proposer, in accordance with Florida Statute 287.087 hereby certifies that

Dawnalee Corporation does:

(Name of Business)

1. Publish a statement notifying employees that the unlawful manufacture, distribution, dispensing, possession or use of a controlled substance is prohibited in the workplace and specifying the actions that will be taken against employees for violations of such prohibition.
2. Inform employees about the dangers of drug abuse in the workplace, the business's policy of maintaining a drug-free workplace, any available drug counseling, rehabilitation, and employee assistance programs, and the penalties that may be imposed upon employees for drug abuse violations.
3. Give each employee engaged in providing the commodities or contractual services that are under contract a copy of the Drug-Free statement.
4. Notify the employees that as a condition of working on the commodities or contractual services that are under contract, employee will abide by the terms of the statement and will notify the employer of any conviction of, or plea of guilty or nolo contendere to, any violation of Chapter 893 or of any controlled substance law of the United States or any state, for a violation occurring in the workplace no later than five (5) days after such conviction.
5. Impose a sanction on, or require the satisfactory participation in a drug abuse assistance or rehabilitation program if such is available in the employee's community, by any employee who is so convicted.
6. Make a good faith effort to continue to maintain a drug-free workplace through implementation of this section.

As the person authorized to sign the statement, I certify that this business complies fully with the above requirements.

Dawna Ferguson

(Authorized signature)

10/21/19

(Date)

DAWNA FERGUSON

(Print/type name as signed above)

****THIS FORM MUST BE COMPLETED AND RETURNED WITH YOUR SUBMITTAL.**

NON-COLLUSION AFFIDAVIT OF PRIME RESPONDENT

STATE OF Florida

COUNTY OF Seminole

Dawna Ferguson, being duly sworn, deposes and says that:

(1) He/she is President of Sawnall Corporation
Title Firm/Company

the respondent that has submitted the attached response.

(2) He/she is fully informed respecting the preparation and contents of the attached solicitation and of all pertinent circumstances respecting such solicitation.

(3) Such solicitation is genuine and is not a collusive or sham solicitation.

(4) Neither the said respondent nor any of its officers, partners, owners, agent representatives, employees or parties in interest including this affiant, has in any way, colluded, conspired, or agreed, directly or indirectly, with any other respondent, firm or person, to submit a collusive or sham response in connection with the Agreement for which the attached response has been submitted or to refrain from proposing in connection with such Agreement, or has in any manner, directly or indirectly, sought by Agreement or collusion or communication or conference with any other responder, firm or person to fix the price or prices in the attached solicitation or of any other respondent, or to fix any overhead, profit or cost element of the proposed price or the proposed price of any other responder, or to secure through any collusion, conspiracy, connivance or unlawful Agreement any advantage against the City of Winter Springs, Florida, or any person interested in the proposed Agreement.

(5) The price or prices quoted in the attached response are fair and proper and are not tainted by any collusion, conspiracy, or unlawful Agreement on the part of the proposer or any of its agents, representatives, owners, employees, or parties of interest including affiant.

Dawna Ferguson

(Signed)

President

(Title)

STATE OF FLORIDA

COUNTY OF SEMINOLE

The foregoing instrument was acknowledged before me this 10/21/19 by DAWNA FERGUSON who is personally known to me or who has produced FL ID as identification and who did (did not) take an oath.

[Signature] (Signature of Notary Public)

EDWIN ADAMES (Name of Notary Typed, Printed or Stamped)

Notary Public GG 334856 (Commission Number)

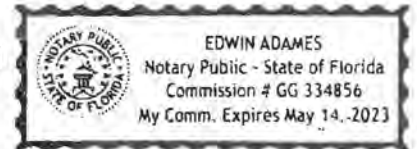

****THIS FORM MUST BE COMPLETED AND RETURNED WITH YOUR SUBMITTAL.**

Client#: 10598

DAWNALEE

ACORD™

CERTIFICATE OF LIABILITY INSURANCE

DATE (MM/DD/YYYY)

1/03/2019

THIS CERTIFICATE IS ISSUED AS A MATTER OF INFORMATION ONLY AND CONFERS NO RIGHTS UPON THE CERTIFICATE HOLDER. THIS CERTIFICATE DOES NOT AFFIRMATIVELY OR NEGATIVELY AMEND, EXTEND OR ALTER THE COVERAGE AFFORDED BY THE POLICIES BELOW. THIS CERTIFICATE OF INSURANCE DOES NOT CONSTITUTE A CONTRACT BETWEEN THE ISSUING INSURER(S), AUTHORIZED REPRESENTATIVE OR PRODUCER, AND THE CERTIFICATE HOLDER.

IMPORTANT: If the certificate holder is an ADDITIONAL INSURED, the policy(ies) must have ADDITIONAL INSURED provisions or be endorsed. If SUBROGATION IS WAIVED, subject to the terms and conditions of the policy, certain policies may require an endorsement. A statement on this certificate does not confer any rights to the certificate holder in lieu of such endorsement(s).

PRODUCER Bouchard Insurance (KIS) 222 Church Street Kissimmee, FL 34741 407 847-2841	CONTACT NAME:			
	PHONE (A/C, No, Ext):	407 847-2841	FAX (A/C, No): 407 846-2841	
	E-MAIL ADDRESS:	clcert@bouchardinsurance.com		
INSURED Dawnalee Corporation 216 Stoner Rd Winter Springs, FL 32708	INSURER(S) AFFORDING COVERAGE		NAIC #	
	INSURER A : Southern Owners Insurance Co		10190	
	INSURER B : Lancer Indemnity Co			
	INSURER C :			
	INSURER D :			
	INSURER E :			
INSURER F :				

COVERAGES CERTIFICATE NUMBER: REVISION NUMBER:

THIS IS TO CERTIFY THAT THE POLICIES OF INSURANCE LISTED BELOW HAVE BEEN ISSUED TO THE INSURED NAMED ABOVE FOR THE POLICY PERIOD INDICATED. NOTWITHSTANDING ANY REQUIREMENT, TERM OR CONDITION OF ANY CONTRACT OR OTHER DOCUMENT WITH RESPECT TO WHICH THIS CERTIFICATE MAY BE ISSUED OR MAY PERTAIN, THE INSURANCE AFFORDED BY THE POLICIES DESCRIBED HEREIN IS SUBJECT TO ALL THE TERMS, EXCLUSIONS AND CONDITIONS OF SUCH POLICIES. LIMITS SHOWN MAY HAVE BEEN REDUCED BY PAID CLAIMS.

INSR LTR	TYPE OF INSURANCE	ADDL INSR	SUBR WVD	POLICY NUMBER	POLICY EFF (MM/DD/YYYY)	POLICY EXP (MM/DD/YYYY)	LIMITS
A	<input checked="" type="checkbox"/> COMMERCIAL GENERAL LIABILITY <input type="checkbox"/> CLAIMS-MADE <input checked="" type="checkbox"/> OCCUR		<input checked="" type="checkbox"/>	72075286	01/01/2019	01/01/2020	EACH OCCURRENCE \$1,000,000 DAMAGE TO RENTED PREMISES (Ea occurrence) \$300,000 MED EXP (Any one person) \$10,000 PERSONAL & ADV INJURY \$1,000,000 GENERAL AGGREGATE \$1,000,000 PRODUCTS - COMP/OP AGG \$1,000,000 \$
	GENL AGGREGATE LIMIT APPLIES PER: <input type="checkbox"/> POLICY <input type="checkbox"/> PRO-JECT <input type="checkbox"/> LOC OTHER:						
	AUTOMOBILE LIABILITY <input type="checkbox"/> ANY AUTO OWNED AUTOS ONLY <input type="checkbox"/> HIRED AUTOS ONLY <input type="checkbox"/> SCHEDULED AUTOS NON-OWNED AUTOS ONLY						COMBINED SINGLE LIMIT (Ea accident) \$ BODILY INJURY (Per person) \$ BODILY INJURY (Per accident) \$ PROPERTY DAMAGE (Per accident) \$ \$
	UMBRELLA LIAB EXCESS LIAB DED RETENTION \$						EACH OCCURRENCE \$ AGGREGATE \$ \$
B	WORKERS COMPENSATION AND EMPLOYERS' LIABILITY ANY PROPRIETOR/PARTNER/EXECUTIVE OFFICER/MEMBER EXCLUDED? (Mandatory in NH) If yes, describe under DESCRIPTION OF OPERATIONS below		<input checked="" type="checkbox"/>	10168	01/01/2019	01/01/2020	<input checked="" type="checkbox"/> PER STATUTE <input type="checkbox"/> OTH-ER E.L. EACH ACCIDENT \$500,000 E.L. DISEASE - EA EMPLOYEE \$500,000 E.L. DISEASE - POLICY LIMIT \$500,000

DESCRIPTION OF OPERATIONS / LOCATIONS / VEHICLES (ACORD 101, Additional Remarks Schedule, may be attached if more space is required)

Waiver of subrogation applies in favor of certificate holder as respects Workers Comp only if required by written contract, and subject to the terms, conditions and exclusions as specified in the policy.

CERTIFICATE HOLDER

CANCELLATION

City of Winter Springs 1126 SR 434 Winter Springs, FL 32708	SHOULD ANY OF THE ABOVE DESCRIBED POLICIES BE CANCELLED BEFORE THE EXPIRATION DATE THEREOF, NOTICE WILL BE DELIVERED IN ACCORDANCE WITH THE POLICY PROVISIONS.
	AUTHORIZED REPRESENTATIVE 

© 1988-2015 ACORD CORPORATION. All rights reserved.

6037V - CERTIFICATE OF AUTOMOBILE LIABILITY INSURANCE

36064-2-F - 2 F
Agent 2026
AFO AE9

This certificate is issued for informational purposes only. It does not change the provisions of the policy shown below.
State Farm Mutual Automobile Insurance Company, of Bloomington, Illinois
certifies that liability coverage is in effect for the Named Insured and vehicle(s) as shown below:

Name and Address of Insured:

DAWNALEE CORP
216 STONER RD
WINTER SPGS FL 32708-3122

Policy Number: P24 8567-A22-59M

Effective Date of Policy: JUL 16 2019

Vehicle(s) Insured:

2014 CHEVROLET 3G0PCPEC5EG470996

LIABILITY COVERAGE

Bodily Injury and Property Damage \$1000000 Each Accident (Single Limit)

Name and Address of Certificate Holder

CITY OF WINTER SPRINGS
1126 EAST SR 434
WINTER SPGS FL 32708-2799

Name and Address of Agent

FRED FRANZ
PO BOX 621046
OVIEDO, FL 32762-1046

CANCELLATION - If the policy shown above is cancelled or otherwise terminated, State Farm Mutual Automobile Insurance Company will endeavor to mail or deliver 10 days prior written notice to the Certificate Holder. State Farm Mutual Automobile Insurance Company, its agents and representatives shall not be liable for any failure to mail or deliver such notice.

6037V

Thirty (30) days cancellation notice required.

The undersigned firm agrees to obtain, prior to award, if selected, insurance as stated above.

Sawna Corporation
PROPOSER/BIDDER

Sawna Ferguson
AUTHORIZED SIGNATURE

President
OFFICER TITLE

10/31/2019
DATE

****THIS FORM MUST BE COMPLETED AND RETURNED WITH YOUR SUBMITTAL.**

Effective: 10/1/2019

Expiration: 9/30/2020

**CITY OF WINTER SPRINGS
BUSINESS TAX RECEIPT**

Business ID: 10233
HOME BASED NON-REGULATED

DAWNALEE CORPORATION
216 STONER RD

DESCRIPTION OF BUSINESS ACTIVITIES

LAWN MAINTENANCE

Incorporated
1959

1126 East State Road 434 • Winter Springs, FL 32708 • (407) 327-1800
www.winterspringsfl.org

BUSINESS TAX RECEIPT INCLUDES WINTER SPRINGS & SEMINOLE COUNTY TAX

PLEASE CUT ALONG THE DOTTED LINE TO DISPLAY RECEIPT IN BUSINESS

Post the above Receipt in a Conspicuous Location within your Place of Business

Total Amount Paid: \$55.00

Note: Total Amount Paid includes the \$25 Seminole County Business Tax



City Manager

DAWNALEE CORPORATION
216 STONER RD
WINTER SPRINGS, FL 32708



1126 East State Road 434
Winter Springs, FL 32708
Phone: (407) 327-1800

DAWNALEE CORPORATION

DAWNALEE Corporation Reference List

City of Winter Springs
1126 East S. R. 434
Winter Springs, Florida 32708
407 327-1800 XTN 315
Mr. Kevin Maddox

City of Oviedo
400 Alexandria Blvd.
Oviedo, Florida 32765
407 977-6069
Mr. Chris Wenner

MI Homes, Inc.
300 Colonial Center Pkwy
Suite 200
Lake Mary, Florida 32746
407 531-5100
Mr. David Sellars
Purchasing

Central Florida Communities, Inc
1890 State Road 436
Suite 300
Winter Park, Florida 32792
(407) 645-3211
Randy Stowell
Howell Branch Court Facility

CITY OF WINTER SPRINGS REQUEST FOR PROPOSAL LANDSCAPE
MAINTENANCE SERVICES

RFP 07-19

COMPLETED CHECK LIST OF REQUIRED DOCUMENTS

- X COMPANY INFORMATION
- X COMPLETED PROPOSAL FORMS FOR EACH PACKAGE
- X DRUG FREE WORKPLACE FORM
- X NON COLLUSION AFFIDAVIT
- X CERTIFICATE OF INSURANCE
- X HOLD HARMLESS AGREEMENT
- X REFERENCES - At least three professional references
- X COMPLETED CHECK LIST OF REQUIRED DOCUMENTS



RFP 07-19 KM
Addendum 1

Clarification of Basis of Award

The City anticipates award to the Respondent who submits the Proposals judged by the City to be the most advantageous. The City anticipates awarding Agreements to the highest ranked Respondent, but reserves the right to award more or fewer Agreements if it is in the best interest of the City. The City reserves the right to assign work or task orders to various Respondents based on pricing submitted. The City reserves the right to pick and choose Respondent based on ranking. The City reserves the right to enter into the Agreements negotiations with the highest ranked Respondent(s). If the City and any of these Respondent(s) cannot negotiate a successful Agreement, the City may terminate such negotiation(s) and begin negotiation(s) with the next highest ranked Respondent(s). No Respondent shall have any rights against the City arising from such negotiations.

Clarification for Package #5 Tuskawilla Rd, Tuskawilla Lighting and Beautification District, and the Oak Forest Assessment District

1. Location iii Tuskawilla Lighting and Beautification District. Maintenance of this location includes Winter Springs Blvd, east of Tuskawilla Rd, and the North and South fountain entrances into Tuskawilla (at the intersection on Winter Springs Blvd. and Tuskawilla Rd). Disregard subsection (a).

Clarification for Package #6 N. Tuskawilla Rd, Blumberg Blvd, and Market Square

1. Location i Blumberg Blvd. Maintenance of this location is for the Center Median Gardens and Monuments on Blumberg Blvd. Disregard subsection (a).
2. Location ii N. Tuskawilla Rd . Maintenance of this location is for N. Tuskawilla Rd from SR 434 to 100' North of Blumberg Blvd. Disregard subsection (a).

Update to Calendar of Events

The calendar of events has been updated to reflect the cancellation of the October 28, 2019 Commission Meeting. Please see below.

Request for Proposals Advertised	October 4, 2019
Technical Questions Due to the City (written)	October 13, 2019 @ 11:59 PM
Responses to Questions Due from the City	October 14, 2019
Proposals Due to the City	October 23, 2019 @ 10:00 AM
Commission Approval of Qualified Vendor	November 18, 2019
Contract Negotiations	November 19- November 27
Effective Date of Landscaping Services	The week of December 1, 2019

Proposal Form



PACKAGE # #6 BLUMBERG BLVD

Respondent Name (Company): Lawnalce Corp.

Name and Title of Person Completing Form: Laura Ferguson
President

PROPOSED COST

Base Maintenance	\$ 52,350.00
Palm Trimming Greater than 13' OA (per tree)	\$ 45.00 SABAL \$110.00 SYLWESTER/DATE
Crepe Trimming Greater than 13' OA (per tree)	\$ 110.00 EA.
Irrigation Inspections	\$ 45.00 PER HOUR
Mulch- Supplied and Installed (per cubic yard)	\$ 60.00
Fertilizer (per application)	\$14.00 per 1000 sq ft TREES & SHRUBS \$ 6.00 " " " " TURF
Integrated Pest Management (per application)	\$6.00 per 1000 sq ft.
PROPOSAL TOTAL	\$ 52,350.00

PLANT, TREE, AND GROUND COVER INSTALLATION

Not to be included as part of proposal review criteria. Price to include all components of installation including staking, watering in, and one-year warranty.

Annuals (Cost plus %)	100 %
Ground cover (Cost plus %)	100 %
Shrubs (Cost plus %)	100 %
Palms (Cost plus %)	125 %
Canopy trees (Cost plus %)	125 %
Understory trees (Cost plus %)	125 %
Sod (Cost plus %)	125 %

Proposal Form (Continued)



PACKAGE # #6 BLUMBERG BLVD

TREE REMOVAL AND STUMP GRINDING

Not to be included as part of the proposal review criteria. Price to include back fill/sod if needed.

Tree removal 6"	\$ 102.50
Tree removal 12"	\$ 424.75
Tree removal 18"	\$ 665.25
Tree removal 24"	\$ 1464.25
Tree removal 36"	\$ 2050.00

IRRIGATION REPAIR

Not to be included as part of proposal review criteria unless otherwise noted.

Wholesale price of materials plus proposed percentage	20%
Irrigation Technician Hourly Rate	\$ 65.00

Signature of person completing form: *Sawna Ferguson*

DAWNALEE CORPORATION

October 21, 2019

OVERVIEW

Dawnalee Corporation was formed some thirty years ago, with the sole purpose of providing personalized service and performing top quality landscape maintenance for homebuilders and homeowner associations. As our company has grown, we have diversified and are servicing many areas of maintenance clients. Dawnalee Corporation is a Winter Springs based landscape maintenance business. We are proud to have been providing the City of Winter Springs with landscape maintenance service for over 15 years. We have always made certain that our clients had easy and immediate access to our top management and that the doors of communication are always open.

It is important to recognize the Dawnalee Corporation has never invested in any type of advertising. Our entire success has been a result of referrals from our satisfied customers.

Dawnalee currently have fifteen employees with over 175 years combined experience. Dawnalee would be proud for you to contact any of our existing clients. If you have any further questions please feel free to contact either Dawna Ferguson or Robert Rushing.

Dawna Ferguson
Dawnalee Corporation
President

Dawnalee Corporation

Current or previous project experience:

City of Winter Springs
1126 East S. R. 434
Winter Springs, Florida 32708
407 327-1800 XTN 315
Previous: Grounds Maintenance of City Rights of Ways & Ponds

City of Winter Springs
1126 East S. R. 434
Winter Springs, Florida 32708
407 327-1800 XTN 315
Previous: Blumberg Boulevard Medians

City of Winter Springs
1126 East S. R. 434
Winter Springs, Florida 32708
407 327-1800 XTN 315
Current: Grounds Maintenance of SR 434

City of Oviedo
400 Alexandria Blvd.
Oviedo, Florida 32765
407 977-6069
Mr. Chris Wenner
Previous: Grounds Maintenance of , Medians
Water Treatment Facilities and Well Fields

MI Homes, Inc
300 Colonial Center Pkwy
Suite 200
Lake Mary, Florida 32746
407 531-5100
Mr. David Sellars
Purchasing
Currently: All Model & Inventory Homes Maintenance
In Central Florida

DAWNALEE CORPORATION

DAWNALEE Corporation General Information

DAWNALEE Corporation
216 Stoner Road
Winter Springs, Florida 32708
Office: (407) 696-7343
EMAIL: dawna@dawnalee.com

DAWNALEE TAX ID #59-2935428

STATE UCC REGISTRATION NO# 2038732

OCCUPATIONAL LICENSE NO# 0303339

WORKMEN'S COMPENSATION - FUBA INSURANCE CO NO# 10168

GENERAL LIABILITY INSURANCE - AUTO OWNERS INSURANCE CO. NO# 924682

AUTOMOBILE INSURANCE - STATE FARM INSURANCE CO. VARIOUS AUTO

CONTACTS:

Dawna Ferguson President
407 696-7343

Robert Rushing
407 341-8412

SECTION 00700 – DRUG FREE WORKPLACE FORM

The undersigned proposer, in accordance with Florida Statute 287.087 hereby certifies that

Sawanna Corporation does:

(Name of Business)

1. Publish a statement notifying employees that the unlawful manufacture, distribution, dispensing, possession or use of a controlled substance is prohibited in the workplace and specifying the actions that will be taken against employees for violations of such prohibition.
2. Inform employees about the dangers of drug abuse in the workplace, the business's policy of maintaining a drug-free workplace, any available drug counseling, rehabilitation, and employee assistance programs, and the penalties that may be imposed upon employees for drug abuse violations.
3. Give each employee engaged in providing the commodities or contractual services that are under contract a copy of the Drug-Free statement.
4. Notify the employees that as a condition of working on the commodities or contractual services that are under contract, employee will abide by the terms of the statement and will notify the employer of any conviction of, or plea of guilty or nolo contendere to, any violation of Chapter 893 or of any controlled substance law of the United States or any state, for a violation occurring in the workplace no later than five (5) days after such conviction.
5. Impose a sanction on, or require the satisfactory participation in a drug abuse assistance or rehabilitation program if such is available in the employee's community, by any employee who is so convicted.
6. Make a good faith effort to continue to maintain a drug-free workplace through implementation of this section.

As the person authorized to sign the statement, I certify that this business complies fully with the above requirements.

Dawna Ferguson

(Authorized signature)

10/21/19

(Date)

DAWNA FERGUSON

(Print/type name as signed above)

****THIS FORM MUST BE COMPLETED AND RETURNED WITH YOUR SUBMITTAL.**

NON-COLLUSION AFFIDAVIT OF PRIME RESPONDENT

STATE OF Florida)

COUNTY OF Seminole)

Dawna Ferguson being duly sworn, deposes and says that:

(1) He/she is President of Sawmali Corporation
Title Firm/Company

the respondent that has submitted the attached response.

(2) He/she is fully informed respecting the preparation and contents of the attached solicitation and of all pertinent circumstances respecting such solicitation.

(3) Such solicitation is genuine and is not a collusive or sham solicitation.

(4) Neither the said respondent nor any of its officers, partners, owners, agent representatives, employees or parties in interest including this affiant, has in any way, colluded, conspired, or agreed, directly or indirectly, with any other respondent, firm or person, to submit a collusive or sham response in connection with the Agreement for which the attached response has been submitted or to refrain from proposing in connection with such Agreement, or has in any manner, directly or indirectly, sought by Agreement or collusion or communication or conference with any other responder, firm or person to fix the price or prices in the attached solicitation or of any other respondent, or to fix any overhead, profit or cost element of the proposed price or the proposed price of any other responder, or to secure through any collusion, conspiracy, connivance or unlawful Agreement any advantage against the City of Winter Springs, Florida, or any person interested in the proposed Agreement.

(5) The price or prices quoted in the attached response are fair and proper and are not tainted by any collusion, conspiracy, or unlawful Agreement on the part of the proposer or any of its agents, representatives, owners, employees, or parties of interest, including affiant.

Dawna Ferguson

(Signed)

President

(Title)

STATE OF FLORIDA

COUNTY OF SEMINOLE

The foregoing instrument was acknowledged before me this 10/21/19 by DAWNA FERGUSON who is personally known to me or who has produced FIELD as identification and who did (did not) take an oath.

[Signature] (Signature of Notary Public)

EDWIN ADAMES (Name of Notary Typed, Printed or Stamped)

Notary Public 06334856 (Commission Number)

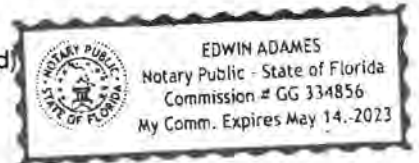

****THIS FORM MUST BE COMPLETED AND RETURNED WITH YOUR SUBMITTAL.**

Client#: 10598

DAWNALEE

ACORD™

CERTIFICATE OF LIABILITY INSURANCE

DATE (MM/DD/YYYY)

1/03/2019

THIS CERTIFICATE IS ISSUED AS A MATTER OF INFORMATION ONLY AND CONFERS NO RIGHTS UPON THE CERTIFICATE HOLDER. THIS CERTIFICATE DOES NOT AFFIRMATIVELY OR NEGATIVELY AMEND, EXTEND OR ALTER THE COVERAGE AFFORDED BY THE POLICIES BELOW. THIS CERTIFICATE OF INSURANCE DOES NOT CONSTITUTE A CONTRACT BETWEEN THE ISSUING INSURER(S), AUTHORIZED REPRESENTATIVE OR PRODUCER, AND THE CERTIFICATE HOLDER.

IMPORTANT: If the certificate holder is an ADDITIONAL INSURED, the policy(ies) must have ADDITIONAL INSURED provisions or be endorsed. If SUBROGATION IS WAIVED, subject to the terms and conditions of the policy, certain policies may require an endorsement. A statement on this certificate does not confer any rights to the certificate holder in lieu of such endorsement(s).

PRODUCER Bouchard Insurance (KIS) 222 Church Street Kissimmee, FL 34741 407 847-2841	CONTACT NAME:		
	PHONE (A/C, No, Ext): 407 847-2841	FAX (A/C, No): 407 846-2841	
	E-MAIL ADDRESS: clcert@bouchardinsurance.com		
INSURED Dawnalee Corporation 216 Stoner Rd Winter Springs, FL 32708	INSURER(S) AFFORDING COVERAGE		NAIC #
	INSURER A : Southern Owners Insurance Co		10190
	INSURER B : Lancer Indemnity Co		
	INSURER C :		
	INSURER D :		
	INSURER E :		
INSURER F :			

COVERAGES

CERTIFICATE NUMBER:

REVISION NUMBER:

THIS IS TO CERTIFY THAT THE POLICIES OF INSURANCE LISTED BELOW HAVE BEEN ISSUED TO THE INSURED NAMED ABOVE FOR THE POLICY PERIOD INDICATED. NOTWITHSTANDING ANY REQUIREMENT, TERM OR CONDITION OF ANY CONTRACT OR OTHER DOCUMENT WITH RESPECT TO WHICH THIS CERTIFICATE MAY BE ISSUED OR MAY PERTAIN, THE INSURANCE AFFORDED BY THE POLICIES DESCRIBED HEREIN IS SUBJECT TO ALL THE TERMS, EXCLUSIONS AND CONDITIONS OF SUCH POLICIES. LIMITS SHOWN MAY HAVE BEEN REDUCED BY PAID CLAIMS.

INSR LTR	TYPE OF INSURANCE	ADDL SUBR INSR WVD	POLICY NUMBER	POLICY EFF (MM/DD/YYYY)	POLICY EXP (MM/DD/YYYY)	LIMITS
A	<input checked="" type="checkbox"/> COMMERCIAL GENERAL LIABILITY <input type="checkbox"/> CLAIMS-MADE <input checked="" type="checkbox"/> OCCUR GEN'L AGGREGATE LIMIT APPLIES PER: <input type="checkbox"/> POLICY <input type="checkbox"/> PRO-JECT <input type="checkbox"/> LOC OTHER:	X	72075286	01/01/2019	01/01/2020	EACH OCCURRENCE \$1,000,000 DAMAGE TO RENTED PREMISES (Ea occurrence) \$300,000 MED EXP (Any one person) \$10,000 PERSONAL & ADV INJURY \$1,000,000 GENERAL AGGREGATE \$1,000,000 PRODUCTS - COMP/OP AGG \$1,000,000 \$ COMBINED SINGLE LIMIT (Ea accident) \$ BODILY INJURY (Per person) \$ BODILY INJURY (Per accident) \$ PROPERTY DAMAGE (Per accident) \$ \$
	AUTOMOBILE LIABILITY <input type="checkbox"/> ANY AUTO OWNED AUTOS ONLY <input type="checkbox"/> HIRED AUTOS ONLY <input type="checkbox"/> SCHEDULED AUTOS NON-OWNED AUTOS ONLY					\$ \$ \$ \$
	UMBRELLA LIAB <input type="checkbox"/> OCCUR EXCESS LIAB <input type="checkbox"/> CLAIMS-MADE DED <input type="checkbox"/> RETENTION \$					EACH OCCURRENCE \$ AGGREGATE \$ \$
B	WORKERS COMPENSATION AND EMPLOYERS' LIABILITY ANY PROPRIETOR/PARTNER/EXECUTIVE OFFICER/MEMBER EXCLUDED? (Mandatory in NH) If yes, describe under DESCRIPTION OF OPERATIONS below	Y/N Y N/A	X 10168	01/01/2019	01/01/2020	<input checked="" type="checkbox"/> PER STATUTE <input type="checkbox"/> OTH-ER E.L. EACH ACCIDENT \$500,000 E.L. DISEASE - EA EMPLOYEE \$500,000 E.L. DISEASE - POLICY LIMIT \$500,000

DESCRIPTION OF OPERATIONS / LOCATIONS / VEHICLES (ACORD 101, Additional Remarks Schedule, may be attached if more space is required)

Waiver of subrogation applies in favor of certificate holder as respects Workers Comp only if required by written contract, and subject to the terms, conditions and exclusions as specified in the policy.

CERTIFICATE HOLDER

CANCELLATION

City of Winter Springs 1126 SR 434 Winter Springs, FL 32708	SHOULD ANY OF THE ABOVE DESCRIBED POLICIES BE CANCELLED BEFORE THE EXPIRATION DATE THEREOF, NOTICE WILL BE DELIVERED IN ACCORDANCE WITH THE POLICY PROVISIONS. AUTHORIZED REPRESENTATIVE 
---	--

© 1988-2015 ACORD CORPORATION. All rights reserved.

6037V - CERTIFICATE OF AUTOMOBILE LIABILITY INSURANCE

36064-2-F - 2 F
Agent 2026
AFO AE9

This certificate is issued for informational purposes only. It does not change the provisions of the policy shown below.
State Farm Mutual Automobile Insurance Company, of Bloomington, Illinois certifies that liability coverage is in effect for the Named Insured and vehicle(s) as shown below:

Name and Address of Insured:

DAWNALEE CORP
216 STONER RD
WINTER SPGS FL 32708-3122

Policy Number: P24 8567-A22-59M

Effective Date of Policy: JUL 16 2019

Vehicle(s) Insured:

2014 CHEVROLET 3GCPCEC5EG470996

LIABILITY COVERAGE

Bodily Injury and Property Damage \$1000000 Each Accident (Single Limit)

Name and Address of Certificate Holder

CITY OF WINTER SPRINGS
1126 EAST SR 434
WINTER SPGS FL 32708-2799

Name and Address of Agent

FRED FRANZ
PO BOX 621046
OVIEDO, FL 32762-1046

CANCELLATION - If the policy shown above is cancelled or otherwise terminated, State Farm Mutual Automobile Insurance Company will endeavor to mail or deliver 10 days prior written notice to the Certificate Holder. State Farm Mutual Automobile Insurance Company, its agents and representatives shall not be liable for any failure to mail or deliver such notice.

6037V

Thirty (30) days cancellation notice required.

The undersigned firm agrees to obtain, prior to award, if selected, insurance as stated above.

Dawnlee Corporation
PROPOSER/BIDDER
Dawn Ferguson
AUTHORIZED SIGNATURE
President
OFFICER TITLE
10/21/2019
DATE

****THIS FORM MUST BE COMPLETED AND RETURNED WITH YOUR SUBMITTAL.**

Effective: 10/1/2019

Expiration: 9/30/2020

**CITY OF WINTER SPRINGS
BUSINESS TAX RECEIPT**

Business ID: 10233
HOME BASED NON-REGULATED

DAWNALEE CORPORATION
216 STONER RD

DESCRIPTION OF BUSINESS ACTIVITIES

LAWN MAINTENANCE

Incorporated
1959

1126 East State Road 434 • Winter Springs, FL 32708 • (407) 327-1800
www.winterspringsfl.org

BUSINESS TAX RECEIPT INCLUDES WINTER SPRINGS & SEMINOLE COUNTY TAX

PLEASE CUT ALONG THE DOTTED LINE TO DISPLAY RECEIPT IN BUSINESS

Post the above Receipt in a Conspicuous Location within your Place of Business

Total Amount Paid: \$55.00

Note: Total Amount Paid includes the \$25 Seminole County Business Tax



City Manager

DAWNALEE CORPORATION
216 STONER RD
WINTER SPRINGS, FL 32708



1126 East State Road 434
Winter Springs, FL 32708
Phone: (407) 327-1800

DAWNALEE CORPORATION

DAWNALEE Corporation Reference List

City of Winter Springs
1126 East S. R. 434
Winter Springs, Florida 32708
407 327-1800 XTN 315
Mr. Kevin Maddox

City of Oviedo
400 Alexandria Blvd.
Oviedo, Florida 32765
407 977-6069
Mr. Chris Wenner

MI Homes, Inc.
300 Colonial Center Pkwy
Suite 200
Lake Mary, Florida 32746
407 531-5100
Mr. David Sellars
Purchasing

Central Florida Communities, Inc
1890 State Road 436
Suite 300
Winter Park, Florida 32792
(407) 645-3211
Randy Stowell
Howell Branch Court Facility

CITY OF WINTER SPRINGS REQUEST FOR PROPOSAL LANDSCAPE
MAINTENANCE SERVICES

RFP 07-19

COMPLETED CHECK LIST OF REQUIRED DOCUMENTS

- X COMPANY INFORMATION
- X COMPLETED PROPOSAL FORMS FOR EACH PACKAGE
- X DRUG FREE WORKPLACE FORM
- X NON COLLUSION AFFIDAVIT
- X CERTIFICATE OF INSURANCE
- HOLD HARMLESS AGREEMENT
- X REFERENCES - At least three professional references
- X COMPLETED CHECK LIST OF REQUIRED DOCUMENTS



RFP 07-19 KM
Addendum 1

Clarification of Basis of Award

The City anticipates award to the Respondent who submits the Proposals judged by the City to be the most advantageous. The City anticipates awarding Agreements to the highest ranked Respondent, but reserves the right to award more or fewer Agreements if it is in the best interest of the City. The City reserves the right to assign work or task orders to various Respondents based on pricing submitted. The City reserves the right to pick and choose Respondent based on ranking. The City reserves the right to enter into the Agreements negotiations with the highest ranked Respondent(s). If the City and any of these Respondent(s) cannot negotiate a successful Agreement, the City may terminate such negotiation(s) and begin negotiation(s) with the next highest ranked Respondent(s). No Respondent shall have any rights against the City arising from such negotiations.

Clarification for Package #5 Tuskawilla Rd, Tuskawilla Lighting and Beautification District, and the Oak Forest Assessment District

1. Location iii Tuscawilla Lighting and Beautification District. Maintenance of this location includes Winter Springs Blvd, east of Tuskawilla Rd, and the North and South fountain entrances into Tuscawilla (at the intersection on Winter Springs Blvd. and Tuskawilla Rd). Disregard subsection (a).

Clarification for Package #6 N. Tuskawilla Rd, Blumberg Blvd, and Market Square

1. Location i Blumberg Blvd. Maintenance of this location is for the Center Median Gardens and Monuments on Blumberg Blvd. Disregard subsection (a).
2. Location ii N. Tuskawilla Rd . Maintenance of this location is for N. Tuskawilla Rd from SR 434 to 100' North of Blumberg Blvd. Disregard subsection (a).

Update to Calendar of Events

The calendar of events has been updated to reflect the cancellation of the October 28, 2019 Commission Meeting. Please see below.

Request for Proposals Advertised	October 4, 2019
Technical Questions Due to the City (written)	October 13, 2019 @ 11:59 PM
Responses to Questions Due from the City	October 14, 2019
Proposals Due to the City	October 23, 2019 @ 10:00 AM
Commission Approval of Qualified Vendor	November 18, 2019
Contract Negotiations	November 19- November 27
Effective Date of Landscaping Services	The week of December 1, 2019



RFP 07-19 KM
Addendum 1

Clarification of Basis of Award

The City anticipates award to the Respondent who submits the Proposals judged by the City to be the most advantageous. The City anticipates awarding Agreements to the highest ranked Respondent, but reserves the right to award more or fewer Agreements if it is in the best interest of the City. The City reserves the right to assign work or task orders to various Respondents based on pricing submitted. The City reserves the right to pick and choose Respondent based on ranking. The City reserves the right to enter into the Agreements negotiations with the highest ranked Respondent(s). If the City and any of these Respondent(s) cannot negotiate a successful Agreement, the City may terminate such negotiation(s) and begin negotiation(s) with the next highest ranked Respondent(s). No Respondent shall have any rights against the City arising from such negotiations.

Clarification for Package #5 Tuskawilla Rd, Tuskawilla Lighting and Beautification District, and the Oak Forest Assessment District

1. Location iii Tuskawilla Lighting and Beautification District. Maintenance of this location includes Winter Springs Blvd, east of Tuskawilla Rd, and the North and South fountain entrances into Tuskawilla (at the intersection on Winter Springs Blvd. and Tuskawilla Rd). Disregard subsection (a).

Clarification for Package #6 N. Tuskawilla Rd, Blumberg Blvd, and Market Square

1. Location i Blumberg Blvd. Maintenance of this location is for the Center Median Gardens and Monuments on Blumberg Blvd. Disregard subsection (a).
2. Location ii N. Tuskawilla Rd . Maintenance of this location is for N. Tuskawilla Rd from SR 434 to 100' North of Blumberg Blvd. Disregard subsection (a).

Update to Calendar of Events

The calendar of events has been updated to reflect the cancellation of the October 28, 2019 Commission Meeting. Please see below.

Request for Proposals Advertised	October 4, 2019
Technical Questions Due to the City (written)	October 13, 2019 @ 11:59 PM
Responses to Questions Due from the City	October 14, 2019
Proposals Due to the City	October 23, 2019 @ 10:00 AM
Commission Approval of Qualified Vendor	November 18, 2019
Contract Negotiations	November 19- November 27
Effective Date of Landscaping Services	The week of December 1, 2019

Proposal Form



PACKAGE # 7 ADDITIONAL ROW AND PONDS

Respondent Name (Company): Lawrence Corp.

Name and Title of Person Completing Form: Naoma Ferguson
President

PROPOSED COST

Base Maintenance	\$ 178,600.00
Palm Trimming Greater than 13' OA (per tree)	\$ 45.00 SABAL \$ 115.00 SYLVESTER / DATE
Crepe Trimming Greater than 13' OA (per tree)	\$ 40.00 EA.
Irrigation Inspections	\$ 45.00 PER HOUR
Mulch- Supplied and Installed (per cubic yard)	\$ 60.00
Fertilizer (per application)	\$ 14.00 per 1000 sq ft SHRUBS \$ 6.00 " " " " TURF
Integrated Pest Management (per application)	\$ 6.00 per 1000 sq ft
PROPOSAL TOTAL	\$ 178,600.00

*

TREES

PLANT, TREE, AND GROUND COVER INSTALLATION

Not to be included as part of proposal review criteria. Price to include all components of installation including staking, watering in, and one-year warranty.

Annuals (Cost plus %)	100	%
Ground cover (Cost plus %)	100	%
Shrubs (Cost plus %)	100	%
Palms (Cost plus %)	125	%
Canopy trees (Cost plus %)	125	%
Understory trees (Cost plus %)	125	%
Sod (Cost plus %)	125	%

Proposal Form (Continued)



PACKAGE # 7 *ADDITIONAL PDW AND PONDS*

TREE REMOVAL AND STUMP GRINDING

Not to be included as part of the proposal review criteria. Price to include back fill/sod if needed.

Tree removal 6"	\$ 102.50
Tree removal 12"	\$ 424.75
Tree removal 18"	\$ 665.25
Tree removal 24"	\$ 1464.25
Tree removal 36"	\$ 2050.00

IRRIGATION REPAIR

Not to be included as part of proposal review criteria unless otherwise noted.

Wholesale price of materials plus proposed percentage	20 %
Irrigation Technician Hourly Rate	\$ 65.00

Signature of person completing form: *Savona Ferguson*

DAWNALEE CORPORATION

DAWNALEE Corporation General Information

DAWNALEE Corporation
216 Stoner Road
Winter Springs, Florida 32708
Office: (407) 696-7343
EMAIL: dawna@dawnalee.com

DAWNALEE TAX ID #59-2935428

STATE UCC REGISTRATION NO# 2038732

OCCUPATIONAL LICENSE NO# 0303339

WORKMEN'S COMPENSATION - FUBA INSURANCE CO NO# 10168

GENERAL LIABILITY INSURANCE - AUTO OWNERS INSURANCE CO. NO# 924682

AUTOMOBILE INSURANCE - STATE FARM INSURANCE CO, VARIOUS AUTO

CONTACTS:

Dawna Ferguson President
407 696-7343

Robert Rushing
407 341-8412

DAWNALEE CORPORATION

October 21, 2019

OVERVIEW

Dawnalee Corporation was formed some thirty years ago, with the sole purpose of providing personalized service and performing top quality landscape maintenance for homebuilders and homeowner associations. As our company has grown, we have diversified and are servicing many areas of maintenance clients. Dawnalee Corporation is a Winter Springs based landscape maintenance business. We are proud to have been providing the City of Winter Springs with landscape maintenance service for over 15 years. We have always made certain that our clients had easy and immediate access to our top management and that the doors of communication are always open.

It is important to recognize the Dawnalee Corporation has never invested in any type of advertising. Our entire success has been a result of referrals from our satisfied customers.

Dawnalee currently have fifteen employees with over 175 years combined experience. Dawnalee would be proud for you to contact any of our existing clients. If you have any further questions please feel free to contact either Dawna Ferguson or Robert Rushing.

Dawna Ferguson
Dawnalee Corporation
President

Dawnalee Corporation

Current or previous project experience:

City of Winter Springs

1126 East S. R. 434

Winter Springs, Florida 32708

407 327-1800 XTN 315

Previous: Grounds Maintenance of City Rights of Ways & Ponds

City of Winter Springs

1126 East S. R. 434

Winter Springs, Florida 32708

407 327-1800 XTN 315

Previous: Blumberg Boulevard Medians

City of Winter Springs

1126 East S. R. 434

Winter Springs, Florida 32708

407 327-1800 XTN 315

Current: Grounds Maintenance of SR 434

City of Oviedo

400 Alexandria Blvd.

Oviedo, Florida 32765

407 977-6069

Mr. Chris Wenner

Previous: Grounds Maintenance of , Medians
Water Treatment Facilities and Well Fields

MI Homes, Inc

300 Colonial Center Pkwy

Suite 200

Lake Mary, Florida 32746

407 531-5100

Mr. David Sellars

Purchasing

Currently: All Model & Inventory Homes Maintenance
In Central Florida

SECTION 00700 – DRUG FREE WORKPLACE FORM

The undersigned proposer, in accordance with Florida Statute 287.087 hereby certifies that

Savnacc Corporation does:

(Name of Business)

1. Publish a statement notifying employees that the unlawful manufacture, distribution, dispensing, possession or use of a controlled substance is prohibited in the workplace and specifying the actions that will be taken against employees for violations of such prohibition.
2. Inform employees about the dangers of drug abuse in the workplace, the business's policy of maintaining a drug-free workplace, any available drug counseling, rehabilitation, and employee assistance programs, and the penalties that may be imposed upon employees for drug abuse violations.
3. Give each employee engaged in providing the commodities or contractual services that are under contract a copy of the Drug-Free statement.
4. Notify the employees that as a condition of working on the commodities or contractual services that are under contract, employee will abide by the terms of the statement and will notify the employer of any conviction of, or plea of guilty or nolo contendere to, any violation of Chapter 893 or of any controlled substance law of the United States or any state, for a violation occurring in the workplace no later than five (5) days after such conviction.
5. Impose a sanction on, or require the satisfactory participation in a drug abuse assistance or rehabilitation program if such is available in the employee's community, by any employee who is so convicted.
6. Make a good faith effort to continue to maintain a drug-free workplace through implementation of this section.

As the person authorized to sign the statement, I certify that this business complies fully with the above requirements.

Dawna Ferguson

(Authorized signature)

10/21/19

(Date)

DAWNA FERGUSON

(Print/type name as signed above)

****THIS FORM MUST BE COMPLETED AND RETURNED WITH YOUR SUBMITTAL.**

NON-COLLUSION AFFIDAVIT OF PRIME RESPONDENT

STATE OF Florida

COUNTY OF Seminole

Dawna Ferguson, being duly sworn, deposes and says that:

(1) He/she is President of Dawna Ferguson Corporation
Title Firm/Company

the respondent that has submitted the attached response.

(2) He/she is fully informed respecting the preparation and contents of the attached solicitation and of all pertinent circumstances respecting such solicitation.

(3) Such solicitation is genuine and is not a collusive or sham solicitation.

(4) Neither the said respondent nor any of its officers, partners, owners, agent representatives, employees or parties in interest including this affiant, has in any way, colluded, conspired, or agreed, directly or indirectly, with any other respondent, firm or person, to submit a collusive or sham response in connection with the Agreement for which the attached response has been submitted or to refrain from proposing in connection with such Agreement, or has in any manner, directly or indirectly, sought by Agreement or collusion or communication or conference with any other responder, firm or person to fix the price or prices in the attached solicitation or of any other respondent, or to fix any overhead, profit or cost element of the proposed price or the proposed price of any other responder, or to secure through any collusion, conspiracy, connivance or unlawful Agreement any advantage against the City of Winter Springs, Florida, or any person interested in the proposed Agreement.

(5) The price or prices quoted in the attached response are fair and proper and are not tainted by any collusion, conspiracy, or unlawful Agreement on the part of the proposer or any of its agents, representatives, owners, employees, or parties of interest, including affiant.

Dawna Ferguson

(Signed) President

(Title)

STATE OF FLORIDA

COUNTY OF SEMINOLE

The foregoing instrument was acknowledged before me this 10/21/19 by DAWNA FERGUSON who is personally known to me or who has produced FL DL as identification and who did (did not) take an oath.

[Signature] (Signature of Notary Public)

EDWIN ADAMES (Name of Notary Typed, Printed or Stamped)

Notary Public 06334056 (Commission Number)

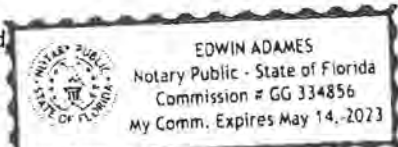

****THIS FORM MUST BE COMPLETED AND RETURNED WITH YOUR SUBMITTAL.**

Client#: 10598

DAWNALEE

ACORD™

CERTIFICATE OF LIABILITY INSURANCE

DATE (MM/DD/YYYY)

1/03/2019

THIS CERTIFICATE IS ISSUED AS A MATTER OF INFORMATION ONLY AND CONFERS NO RIGHTS UPON THE CERTIFICATE HOLDER. THIS CERTIFICATE DOES NOT AFFIRMATIVELY OR NEGATIVELY AMEND, EXTEND OR ALTER THE COVERAGE AFFORDED BY THE POLICIES BELOW. THIS CERTIFICATE OF INSURANCE DOES NOT CONSTITUTE A CONTRACT BETWEEN THE ISSUING INSURER(S), AUTHORIZED REPRESENTATIVE OR PRODUCER, AND THE CERTIFICATE HOLDER.

IMPORTANT: If the certificate holder is an ADDITIONAL INSURED, the policy(ies) must have ADDITIONAL INSURED provisions or be endorsed. If SUBROGATION IS WAIVED, subject to the terms and conditions of the policy, certain policies may require an endorsement. A statement on this certificate does not confer any rights to the certificate holder in lieu of such endorsement(s).

PRODUCER Bouchard Insurance (KIS) 222 Church Street Kissimmee, FL 34741 407 847-2841	CONTACT NAME:		
	PHONE (A/C, No, Ext):	407 847-2841	FAX (A/C, No): 407 846-2841
	E-MAIL ADDRESS:	clcert@bouchardinsurance.com	
INSURED Dawnalee Corporation 216 Stoner Rd Winter Springs, FL 32708	INSURER(S) AFFORDING COVERAGE		NAIC #
	INSURER A : Southern Owners Insurance Co		10190
	INSURER B : Lancer Indemnity Co		
	INSURER C :		
	INSURER D :		
	INSURER E :		
INSURER F :			

COVERAGES CERTIFICATE NUMBER: REVISION NUMBER:

THIS IS TO CERTIFY THAT THE POLICIES OF INSURANCE LISTED BELOW HAVE BEEN ISSUED TO THE INSURED NAMED ABOVE FOR THE POLICY PERIOD INDICATED. NOTWITHSTANDING ANY REQUIREMENT, TERM OR CONDITION OF ANY CONTRACT OR OTHER DOCUMENT WITH RESPECT TO WHICH THIS CERTIFICATE MAY BE ISSUED OR MAY PERTAIN, THE INSURANCE AFFORDED BY THE POLICIES DESCRIBED HEREIN IS SUBJECT TO ALL THE TERMS, EXCLUSIONS AND CONDITIONS OF SUCH POLICIES. LIMITS SHOWN MAY HAVE BEEN REDUCED BY PAID CLAIMS.

INSR LTR	TYPE OF INSURANCE	ADDL SUBR INSR WVD	POLICY NUMBER	POLICY EFF (MM/DD/YYYY)	POLICY EXP (MM/DD/YYYY)	LIMITS
A	<input checked="" type="checkbox"/> COMMERCIAL GENERAL LIABILITY <input type="checkbox"/> CLAIMS-MADE <input checked="" type="checkbox"/> OCCUR GEN'L AGGREGATE LIMIT APPLIES PER: <input type="checkbox"/> POLICY <input type="checkbox"/> PRO-JECT <input type="checkbox"/> LOC OTHER:	X	72075286	01/01/2019	01/01/2020	EACH OCCURRENCE \$1,000,000 DAMAGE TO RENTED PREMISES (Ea occurrence) \$300,000 MED EXP (Any one person) \$10,000 PERSONAL & ADV INJURY \$1,000,000 GENERAL AGGREGATE \$1,000,000 PRODUCTS - COM/OP AGG \$1,000,000 \$ COMBINED SINGLE LIMIT (Ea accident) \$ BODILY INJURY (Per person) \$ BODILY INJURY (Per accident) \$ PROPERTY DAMAGE (Per accident) \$ \$
	AUTOMOBILE LIABILITY <input type="checkbox"/> ANY AUTO OWNED AUTOS ONLY <input type="checkbox"/> HIRED AUTOS ONLY <input type="checkbox"/> SCHEDULED AUTOS <input type="checkbox"/> NON-OWNED AUTOS ONLY					EACH OCCURRENCE \$ AGGREGATE \$ \$
	UMBRELLA LIAB <input type="checkbox"/> OCCUR EXCESS LIAB <input type="checkbox"/> CLAIMS-MADE DED RETENTION \$					EACH OCCURRENCE \$ AGGREGATE \$ \$
B	WORKERS COMPENSATION AND EMPLOYERS' LIABILITY ANY PROPRIETOR/PARTNER/EXECUTIVE OFFICER/MEMBER EXCLUDED? <input checked="" type="checkbox"/> Y/N (Mandatory in NH) If yes, describe under DESCRIPTION OF OPERATIONS below	X	10168	01/01/2019	01/01/2020	<input checked="" type="checkbox"/> PER STATUTE <input type="checkbox"/> OTH-ER E.L. EACH ACCIDENT \$500,000 E.L. DISEASE - EA EMPLOYEE \$500,000 E.L. DISEASE - POLICY LIMIT \$500,000

DESCRIPTION OF OPERATIONS / LOCATIONS / VEHICLES (ACORD 101, Additional Remarks Schedule, may be attached if more space is required)

Waiver of subrogation applies in favor of certificate holder as respects Workers Comp only if required by written contract, and subject to the terms, conditions and exclusions as specified in the policy.

CERTIFICATE HOLDER City of Winter Springs 1126 SR 434 Winter Springs, FL 32708	CANCELLATION SHOULD ANY OF THE ABOVE DESCRIBED POLICIES BE CANCELLED BEFORE THE EXPIRATION DATE THEREOF, NOTICE WILL BE DELIVERED IN ACCORDANCE WITH THE POLICY PROVISIONS.
	AUTHORIZED REPRESENTATIVE 

© 1988-2015 ACORD CORPORATION. All rights reserved.

6037V - CERTIFICATE OF AUTOMOBILE LIABILITY INSURANCE

36064-2-F - 2 F
Agent 2026
AFO AE9

This certificate is issued for informational purposes only. It does not change the provisions of the policy shown below.
State Farm Mutual Automobile Insurance Company _____, of Bloomington, Illinois
certifies that liability coverage is in effect for the Named Insured and vehicle(s) as shown below:

Name and Address of Insured:

DAWNALEE CORP
216 STONER RD
WINTER SPGS FL 32708-3122

Policy Number: P24 8567-A22-59M

Effective Date of Policy: JUL 16 2019

Vehicle(s) Insured:

2014 CHEVROLET 3GCPCEC5EG470996

LIABILITY COVERAGE

Bodily Injury and Property Damage \$1000000 Each Accident (Single Limit)

Name and Address of Certificate Holder

CITY OF WINTER SPRINGS
1126 EAST SR 434
WINTER SPGS FL 32708-2799

Name and Address of Agent

FRED FRANZ
PO BOX 621046
OVIEDO, FL 32762-1046

CANCELLATION - If the policy shown above is cancelled or otherwise terminated, State Farm Mutual Automobile Insurance Company will endeavor to mail or deliver 10 days prior written notice to the Certificate Holder. State Farm Mutual Automobile Insurance Company, its agents and representatives shall not be liable for any failure to mail or deliver such notice.

6037V

157-6037V Rev. 08-16-2006 (01a0/073b)

Thirty (30) days cancellation notice required.

The undersigned firm agrees to obtain, prior to award, if selected, insurance as stated above.

PROPOSER/BIDDER Sturman Corp.
AUTHORIZED SIGNATURE Laura Ferguson
OFFICER TITLE President
DATE 10/21/2019

****THIS FORM MUST BE COMPLETED AND RETURNED WITH YOUR SUBMITTAL.**

Effective: 10/1/2019

Expiration: 9/30/2020

**CITY OF WINTER SPRINGS
BUSINESS TAX RECEIPT**

Business ID: 10233
HOME BASED NON-REGULATED

DAWNALEE CORPORATION
216 STONER RD

DESCRIPTION OF BUSINESS ACTIVITIES

LAWN MAINTENANCE

Incorporated
1959

1126 East State Road 434 • Winter Springs, FL 32708 • (407) 327-1800
www.winterspringsfl.org

BUSINESS TAX RECEIPT INCLUDES WINTER SPRINGS & SEMINOLE COUNTY TAX

PLEASE CUT ALONG THE DOTTED LINE TO DISPLAY RECEIPT IN BUSINESS

Post the above Receipt in a Conspicuous Location within your Place of Business

Total Amount Paid: \$55.00

Note: Total Amount Paid includes the \$25 Seminole County Business Tax

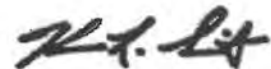

City Manager

DAWNALEE CORPORATION
216 STONER RD
WINTER SPRINGS, FL 32708



1126 East State Road 434
Winter Springs, FL 32708
Phone: (407) 327-1800

DAWNALEE CORPORATION

DAWNALEE Corporation Reference List

City of Winter Springs
1126 East S. R. 434
Winter Springs, Florida 32708
407 327-1800 XTN 315
Mr. Kevin Maddox

City of Oviedo
400 Alexandria Blvd.
Oviedo, Florida 32765
407 977-6069
Mr. Chris Wenner

MI Homes, Inc.
300 Colonial Center Pkwy
Suite 200
Lake Mary, Florida 32746
407 531-5100
Mr. David Sellars
Purchasing

Central Florida Communities, Inc
1890 State Road 436
Suite 300
Winter Park, Florida 32792
(407) 645-3211
Randy Stowell
Howell Branch Court Facility

CITY OF WINTER SPRINGS REQUEST FOR PROPOSAL LANDSCAPE
MAINTENANCE SERVICES

RFP 07-19

COMPLETED CHECK LIST OF REQUIRED DOCUMENTS

- X COMPANY INFORMATION
- X COMPLETED PROPOSAL FORMS FOR EACH PACKAGE
- X DRUG FREE WORKPLACE FORM
- X NON COLLUSION AFFIDAVIT
- X CERTIFICATE OF INSURANCE
- X HOLD HARMLESS AGREEMENT
- X REFERENCES - At least three professional references
- X COMPLETED CHECK LIST OF REQUIRED DOCUMENTS



RFP 07-19 KM
Addendum 2 (9 pages)

Maps for Central Winds Park
Please see the below map for Central Winds Park. Please notice that only the common areas are to be included in this proposal; the athletic fields are not part of this contract.



- | | | |
|-----------------|-------------------------------------|--|
| 1. Dog Park | 4. Amphitheater | 7. Central Winds Parkway & Orange Avenue |
| 2. Lower Fields | 5. Baseball and Soccer Parking Lots | |
| 3. Passive Area | 6. Front Entrance | 8. Upper Fields |

Contract Length

The length of the contract will be two-years *with the possibility* of three (3) one-year extensions.

Site Visits

Site visits for the packages are not planned. To view the areas and provide more information for proposal formulation, use of Google Earth or other satellite imaging software is suggested.

Turf Species Frequencies

Mowing should be 40-42x per year for all species of turf.

Minor irrigation repairs

Minor irrigation repairs are not included and all repairs over \$50 need to be ~~proposed~~ preapproved prior to repair.

Spanish Moss Removal

Spanish moss will be removed by the request of the City.

Fig Vines- Oak Forest Wall

The fig vines will be trimmed twice per month during the growing season and once per month during the dormant season.

Location elaboration

The senior center should be included in the Sunshine Park proposal.

The road coming off of SR 434 to the West Wastewater Treatment Facility is not included in the proposal. Below is the property area for this location.



Current Landscaping Contracts

We have forwarded your request for current landscaping contracts to our City Clerk as a public records request.

Additional Proposal Package

Package #7- Additional ROW and Ponds

A. Locations and Property Description

- i. N. Edgemon R.O.W.**
 - a. Eastside – 3rd St to Canal
 - b. Westside – Senior Center to VFW Driveway
 - c. Westside – From Shepard Rd. to S.R. 419

- ii. N. Edgemon Traffic Medians**
 - a. From SR434 to Shepard Road
- iii. Bombay R.O.W.**
 - a. Westside – From 1st St. lot south to chain link fence including open area next to fence
- iv. S. Edgemon R.O.W. at Duke Energy Easement**
 - a. R.O.W. both sides and around bollards
- v. S. Moss Road Islands**
- vi. Murphy Road Island**
- vii. S. Edgemon Island**
- viii. Lombardy Canal**
 - a. Both sides
- ix. S. Flamingo Canal**
 - a. Both sides – from S. Moss to S. Edgemon Ave.
- x. Burgos Easement**
 - a. Between 113 and 115 Burgos Rd. south to S. Flamingo canal
- xi. Burgos/Edgemon R.O.W.**
 - a. From canal north to side lot at 111 S. Edgemon Ave.
- xii. S. Moss R.O.W.**
 - a. East side from canal north to Hacienda Village entrance
 - b. East side from S. Mosswood Circle to Dolphin Road
 - c. West Side from 434 to Church property line
- xiii. Bayberry Ct. Island**
- xiv. Dogwood Ct. Island**
- xv. Lombardy/Burgos R.O.W.**
 - a. Area between 120 and 110 Lombardy Road south to Burgos Road
- xvi. Cedarwood Ct. Island**
- xvii. Cypress Ct. Island**
- xviii. S. Moss Bridge R.O.W.**
 - a. Four corners of bridge and west side R.O.W. from bridge to fence at back of Elderwood Street
- xix. Murphy Road R.O.W. at Duke Energy Easement**

- a. R.O.W. both sides and around bollards
- xx. S. Edgemon Bridge/ R.O.W.**
 - a. Four corners at bridge area and ROW on eastside of S. Edgemon from Panama Road north to lot line @ 727 S. Edgemon
- xxi. Murphy Road Bridge R.O.W.**
 - a. Four corners of bridge area
- xxii. Charles St. Island**
- xxiii. Sherry Ave R.O.W.**
 - a. Westside ROW from SR419 to San Rafael Street
- xxiv. Sherry Ave. Medians**
 - a. Traffic calming medians from SR434 to SR419
 - b. ROW from San Gabriel N to SR419
- xxv. Wade St. Medians**
 - a. Traffic calming medians from SR434 to SR419
- xxvi. Hayes Road R.O.W.**
 - a. Westside from SR434 to Ranchlands sign just S. of Sailfish
 - b. Eastside from corner of SR434 to property line at Pearl Road
- xxvii. Pearl Road Islands**
- xxviii. Hayes Road Bridge/R.O.W.**
 - a. Four corners of bridge area including field on southeast corner of Alton Road and Hayes Road
- xxix. S. Moss Road R.O.W. Swales**
 - a. Both sides of ROW one mower width behind trail
- xxx. Panama Road R.O.W. Swales**
 - a. Both sides of ROW one mower width behind trail
- xxxi. Hayes Road R.O.W. Swales**
 - a. Both sides of ROW one mower width behind trail
- xxxii. Fisher Road R.O.W. and Field**
 - a. Westside from Morton Lane south to phone box including drainage field
- xxxiii. Alton Road Bridge/R.O.W.**
 - a. Four corners of bridge area and ROW
- xxxiv. Shore Road Bridge/R.O.W.**
 - a. Eastside corners and ROW
- xxxv. Mockingbird Easement/R.O.W.**
 - a. Both sides property line to tree line
- xxxvi. Oak Island Road**
- xxxvii. Shore Road Culvert**
 - a. Four corners of culvert
- xxxviii. George Street R.O.W.**
 - a. Area south of ditch from Sherry Street to Wade Street including ditch inlets
- xxxix. N. Moss Road R.O.W.**
 - a. Eastside from SR434 to SR419

- b. Westside from SR434 to SR419
- xli. Highlands R.O.W.'s**
 - a. Sheoah Blvd. – (both sides 18' from edge of pavement) with continuous edging at pavement.
 - b. Shepard Road – (south ROW) beginning at end of Wildwood Subdivision wall and to N. Edgemon Ave and (north ROW) from 1006 (Dittmer) to N. Edgemon Ave. (both sides including field behind sidewalk at effluent disposal ponds)
 - c. Sheoah Circle – (both sides 11' from edge of pavement)
 - d. Third Street – (both sides from Sheoah Blvd. to house lots 13' from edge of pavement)
 - e. MacGregor Road – including Highland Village Ct. island
 - f. Miami Drive Islands (2)
 - g. Jeffrey Ct. island
 - h. Shepard Ct. island
 - i. Sheoah Circle Island
 - j. Kilt Ct.
 - k. Ryan Ct.
- xlii. Dyson Bridge**
 - a. Four corners of bridge area
- xliii. Seneca Blvd. R.O.W.**
 - a. Eastside – from Winter Springs Blvd to house side lot/ both sides of sidewalk
 - b. Westside – from Winter Springs Blvd to Chelsea Woods entrance sign/ both sides of sidewalk
- xliiii. Gary Hillary Drive R.O.W.**
- xliv. Winter Springs Blvd. R.O.W. (Limits of R.O.W. are from edge of to walls or fences)**
 - a. Northside – from Gary Hillary to wall for Tusca Oaks
 - b. Northside – from Northern Way to end of brick wall at 1630 Winter Springs Blvd
 - c. Northside – from Davenport Glen brick wall to property line 1553 Winter Springs Blvd
 - d. Southside – from Fox Glen entrance to Sam Smith Park driveway including perimeter of pond
 - e. Southside – from bridge to Greenbriar Lane
- xlv. Northern Way R.O.W.**
 - a. Westside – Winter Springs Blvd to Cheetah Trail then from water plant to well #4
 - b. Northside – drainage ROW near Tuscora Drive – from property line to property line
 - c. Eastside – near Woodchuck Ct – from Duke Energy easement to Winter Springs Blvd
- xlvi. Northern Way Bridges (3)**

- a. Four corners including ROW
- xlvi. Greenbriar Lane R.O.W.**
 - a. Westside – near Creekside Circle from chain link fence to brick wall
 - b. Westside – from brick wall at Bentley Green to brick wall at Greenbriar Subdivision including Field and pond
 - c. Eastside – near Braewick Street from power transformer to brick wall at Chestnut Ridge including retention swale
- xlvi. Winter Springs Blvd. Bridges (2)**
 - a. Bear Creek – Four corners including pond on northeast side and ROW to brick wall
 - b. Howell Creek – Four Corners including pond on southeast and ROW southwest to Country Club property.
- xlv. N. Tuskawilla R.O.W.**
 - a. Westside – from SR434 to wall at Tuskawilla Trace Subdivision
 - b. Eastside – from McDonald's property line to St Johns Landing subdivision
- i. Sequoia Court Islands**
- ii. Trotwood Blvd. R.O.W. Field**
 - a. ROW field next to property at 1165 Trotwood to 1143 Trotwood (west side)
 - b. Across street – along fence (eastside) and lift station 10E near field
- iii. Wagner's Curve**
 - a. ROW and swale in front of Central Winds Park entrance at telephone house
- iiii. Gary Hillary Dry Pond**
 - a. Dry pond South of the 7-11
- liv. Donut Lake/S. Edgemon Ave.**
 - a. Both sides S Edgemon ROW between houses to edge of lake
- lv. Donut Lake/Murphy Road**
 - a. Area between 627 Murphy Road and rear lot of 217 Cottonwood to edge of Lake
- lvi. Mt. Laurel Pond**
 - a. Perimeter of pond
- lvii. Freedom Lane Pond**
 - a. Berm sides and top and pond bottom when dry.
- lviii. Baltic Lane Pond**
 - a. Berm sides and top and pond bottom when dry.
- lix. Brooks Ct. Pond**
 - a. Berm sides and top and pond bottom when dry.
- lx. Venture Ct. Pond**
 - a. Berm sides and top and pond bottom when dry.
- lxi. Seneca Blvd. Pond**
 - a. Perimeter of pond including ROW
- lxii. Bear Springs Road**

- a. Between Publix and The Rize Apartments ROW from Blumberg north to high school
- b. East Side from Blumberg north to high school
- lxiii. First Street R.O.W.**
 - a. Area across from fire station #26 south side from Moss Road to north Flamingo Ave.
- lxiv. Panama Road R.O.W.**
 - a. Both sides from S. Moss Road to Edgemon Ave.
- lxv. Sam Smith Park R.O.W.**
 - a. ROW directly in front of park.
- lxvi. Papaya Power Easements**
 - a. Power Easements (front areas) on Papaya, one is near Night Owl and the other is near Turkey Hollow.
- lxvii. Winter Springs – Oak Forest R.O.W.**
 - a. Near 1030 Winter Springs Blvd. at chain link fences (both sides of roads). Also on the east side, 1030 to Chokecherry.
- lxviii. Benchwood R.O.W.**
 - a. Chain-link fence areas on Benchwood (both sides) near Winter Springs Blvd.
- lxix. Chokecherry (A) R.O.W.**
 - a. Chain-link fence areas (both sides) near 1085 Chokecherry.
- lxx. Sequoia R.O.W.**
 - a. Chain-link fence areas (both areas) near 983 Sequoia.
- lxxi. Chokecherry (B) R.O.W.**
 - a. Chain-link fence areas (both sides) near Sapling.
- lxxii. Shetland R.O.W.**
 - a. Northern Way (west side) to property line before first driveway near Dyson and Shetland.
- lxxiii. Northern Way R.O.W./Tuscora**
 - a. ROW from property line at Tuscan Place to Tuscora on Northern Way (north side). Service area is from curb line to fence.
- lxxiv. Cross Seminole Trail – Vistawilla**
 - a. Vistawilla and Cross Seminole Trail. Service area is the four corners of the trail excluding the island.
- lxxv. Cross Seminole Trail – Tuscora**
 - a. Tuscora and Cross Seminole Trail. Service area is the four corners of the trail excluding the island.
- lxxvi. Northern Way – Southern Loop R.O.W.**
 - a. ROW along golf course between 1220 and 1218 Northern Way. Service area is from curb to tree line next to fairway.
- lxxvii. Greenbriar and Northern Way Easement**
 - a. Field at Northern Way and Greenbriar. Power line easement south of where Greenbriar ends at Northern Way.
- lxxviii. Fisher Road Medians and R.O.W.**

- a. Medians and ROW the length of Fisher Road from Panama to just past Morton Lane near the entrance to Seville Chase. Area extends from property line to property line on both sides of the road in ROW.
- lxxxix. Cheoy Lee Circle R.O.W.**
 - a. ROW along Cheoy Lee Circle between 662 and 652 from curb line to 5' behind sidewalk.
- lxxx. Northern Way R.O.W. – Southern Bell R.O.W.**
 - a. Empty lot next to fire station. Curb line in approx. 25' and the length of the property along Northern Way.
- lxxxii. Highlands Pond**
 - a. Behind Highlands clubhouse at Shepard Road. Pond and drainage easement and immediate surrounding area to water's edge.
- lxxxiii. Sheoah Circle Easement**
 - a. Across from 898 Stirling Drive. Easement from road into woods to water's edge.
- lxxxiii. Shepard Road Easement**
 - a. East of 3350 SR419, adjacent to pond/fence from Shepard Road to SR419.
- lxxxiv. Bahama Berm**
 - a. Behind homes 709-727 Edgemon Ave., Enter Access gate off of Bahama Road
- lxxxv. Gator Pond**
 - a. Behind Homes 424-430 Hawthorn Circle, access through power easement off of Murphy Road
- lxxxvi. Murphy Pond**
 - a. Behind 608 Murphy Road, enter next to 608 Murphy Road Maintain around pond to water's edge
- lxxxvii. Murphy Lake**
 - a. Enter access path to Murphy lake directly across from Elderwood Street, maintain around most of lake to woods/property lines to water's edge, service area ends behind 301 Panama Circle.
- lxxxviii. Edgemon/Murphy ROW**
 - a. Intersection of Murphy Road and S. Edgemon Ave, maintain ROW easement along S. Edgemon and on Murphy Road.
- lxxxix. Oviedo Line at Winter Springs Blvd**
 - a. South side of Winter Springs Blvd at Seneca, small triangular field.
- xc. Boat Pond**
 - a. Behind homes 1784-1786 Seneca Blvd, maintain around two ponds to water's edge.
- xc. Lamoka Easement**
 - a. Behind homes 1760-1774 Seneca Blvd., access at 1760 Seneca Blvd.
- xcii. Donnas Pond**
 - a. Behind homes 1722-1732 Seneca Blvd., maintain drainage easement.

B. Required Services

- i. All locations in this package
 - a. The below services are required weekly through the growing season (3/15-10/15) and bi-weekly through the dormant season (10/16-3/14)
 - i. Mow, Blow, Trim Hedges, String Trim, Edge, Prune Trees, Remove Spanish Moss, Trash Removal, and other miscellaneous services as requested.



RFP 07-19 KM
Addendum 1

Clarification of Basis of Award

The City anticipates award to the Respondent who submits the Proposals judged by the City to be the most advantageous. The City anticipates awarding Agreements to the highest ranked Respondent, but reserves the right to award more or fewer Agreements if it is in the best interest of the City. The City reserves the right to assign work or task orders to various Respondents based on pricing submitted. The City reserves the right to pick and choose Respondent based on ranking. The City reserves the right to enter into the Agreements negotiations with the highest ranked Respondent(s). If the City and any of these Respondent(s) cannot negotiate a successful Agreement, the City may terminate such negotiation(s) and begin negotiation(s) with the next highest ranked Respondent(s). No Respondent shall have any rights against the City arising from such negotiations.

Clarification for Package #5 Tuskawilla Rd, Tuskawilla Lighting and Beautification District, and the Oak Forest Assessment District

1. Location iii Tuskawilla Lighting and Beautification District. Maintenance of this location includes Winter Springs Blvd, east of Tuskawilla Rd, and the North and South fountain entrances into Tuskawilla (at the intersection on Winter Springs Blvd. and Tuskawilla Rd). Disregard subsection (a).

Clarification for Package #6 N. Tuskawilla Rd, Blumberg Blvd, and Market Square

1. Location i Blumberg Blvd. Maintenance of this location is for the Center Median Gardens and Monuments on Blumberg Blvd. Disregard subsection (a).
2. Location ii N. Tuskawilla Rd . Maintenance of this location is for N. Tuskawilla Rd from SR 434 to 100' North of Blumberg Blvd. Disregard subsection (a).

Update to Calendar of Events

The calendar of events has been updated to reflect the cancellation of the October 28, 2019 Commission Meeting. Please see below.

Request for Proposals Advertised	October 4, 2019
Technical Questions Due to the City (written)	October 13, 2019 @ 11:59 PM
Responses to Questions Due from the City	October 14, 2019
Proposals Due to the City	October 23, 2019 @ 10:00 AM
Commission Approval of Qualified Vendor	November 18, 2019
Contract Negotiations	November 19- November 27
Effective Date of Landscaping Services	The week of December 1, 2019



BrightView 

City of Winter Springs



BrightView Landscape Services, Inc.
1174 Central Florida Parkway
Longwood, FL 32750

October 20, 2019

City of Winter Springs
City Hall
1126 East S.R. 434
Winter Springs, FL 32708
Attention: Kevin Maddox

RE: Landscape Maintenance Services
RFP 07-19 KM
October 2019

Dear Kevin Maddox,

BrightView Landscape Services is pleased to submit our landscape proposal numbers for The City of Winter Springs. BrightView appreciates the partnership we have had over the years and will continue to be committed to keeping your landscape a focal point for the City of Winter Springs. In addition, we look forward to the opportunity to share with you how we can help you achieve an even more beautiful landscape year-round by fulfilling your landscape goals in a sustainable manner over time.

Benefits of a BrightView partnership:

Our Service is not just about delivering a product. It is about creating environments and engaging our partners to assist them in not only meeting their goals today but more importantly exceeding the goals of tomorrow. That requires a partner with the ability to develop a customized service model for the clients we serve and BrightView is that partner. Serving the needs of today's premier properties and communities is of the utmost importance to our entire organization.

BrightView will bring you innovative solutions. Our goal is to continue to partner with you all to create those solutions that ensure the best possible outcomes for the City of Winter Springs, residents and guests you proudly serve each and every day. Our solutions have been successfully implemented at dozens of premier locations and we will customize our solution for your unique situation. We understand that any solution must be provided with the highest level of customer service.



Proactive Communication: We believe it is our job to anticipate the needs of our customers and to ensure that we communicate with them on a regular and frequent basis, so that issues are addressed long before they can become problems. Through our quarterly site evaluation processes, site supervisors and branch manager will review the entire site to identify any areas of concern, and to evaluate the overall appearance of the sites. We also encourage scheduled site walk-through meetings with our local management to discuss the long-term vision for the City of Winter Springs and to ensure we are operating in integrity with the overall goals of the city and its management.

Thank you for the opportunity to continue our partner with you the City of Winter Springs. Should you have any immediate questions please reach out to me at 321-388-3915 or email at Charlie.brough@brightview.com

Sincerely,

Charley Brough

Branch Manager

Your Full Service Landscape Expert

BrightView takes pride in providing the highest-quality landscape with a worry-free, dependable service commitment. As the nation's leading landscape Services Company, we consistently bring excellent landscapes to life at thousands of clients' properties, fostering collaborative relationships to drive clients' success.

A full service landscape company, BrightView can mobilize quickly to respond to special requests that may fall outside of the scope of landscape maintenance. In addition to landscape maintenance, our expertise extends to:

At every stage of your facilities lifecycle, BrightView is here to take care of your landscape.



Design	Develop	Maintain	Enhance
<ul style="list-style-type: none"> • Landscape Architecture & Planning • Design Build • Program Management 	<ul style="list-style-type: none"> • Planting • Hardscaped • Pools & Water Features • Compliance • Tree Growing & Moving 	<ul style="list-style-type: none"> • Landscape • Tree Care • Snow & Ice • Specialty Turf • Exterior Maintenance 	<ul style="list-style-type: none"> • Enhancements • Sustainability • Water Management

Professional Resource

BrightView has the professional resources, local expertise, and a long history of creating beautiful landscapes across the United States which makes us a great partner. BrightView fully understands your expectations for first-class service and will deliver the level of performance you demand.

Our partnership will guarantee the stability of your maintenance operations as well as offer innovative recommendations for landscape improvements.

Our competitive advantages include:

- Deep experience in road way maintenance and facilities maintenance throughout the Central Florida area.
- Over 75 years in business
- 110 employees in the Longwood branch
- Proven success in seamlessly transitioning complex properties



- A comprehensive customer satisfaction program where your feedback is collected via a third-party company
- Proprietary systems and processes designed to maximize performance and communication
- A collaborative relationship with the City of Winter Springs so we are closely partnering and developing long-term, cost-effective strategies
- Unmatched sustainability expertise and environmentally-friendly horticultural best practices that support Florida initiatives

Our Transition Plan and Dedicated Team

BrightView's transition process is a documented action plan that involves both senior and site management by the client and BrightView. This process starts out with the overall vision and goals of the City Of Winter Springs. Implementation plans with specific details and schedules are discussed. Timely meetings to review progress are scheduled for the site and overall teams to ensure success.

Our job start-up process kicks off the transition plan. This initial site meeting and walk-through is done prior to starting the contract to introduce the operations team, determine specific site-related needs of the customer and site specific issues. A site walk-through/tour is done during this time asking more site-specific questions, which clarify the customer needs and specific goals set for upcoming year.



Goals of Initial Site Meeting:

- Establish a weekly communication process (meetings, reports, etc.)
- Present and discuss schedule of operations
- Identify ALL special situations, issues, areas & processes
- Clearly establish a base safety process and site specific processes
- Document a process for out of scope work (P.O., sign-off, billing)
- Share emergency call process
- Set short-term improvement goals
- Benchmark existing site status, conditions and opportunities for improvements

Dedicated Account Manager, for the City of Winter Springs you'll have a main point of contact for all your property needs. The Account Manager's primary focus is providing proactive, outstanding communication and customer service to the property manager and board. They will direct, schedule and oversee all operations that occur on your property including routine maintenance, irrigation, agronomics and specialty services such as tree trimming, mulch and seasonal annuals. They will also partner with you to discuss site improvements and lead monthly meetings and walks to provide property inspections and reporting.

Your Dedicated BrightView Crew, will always be in full uniform – company shirt, pants, belt, hat and work boots. This not only presents a professional look to our team, it also brings positive comments from onsite security and employees who can instantly recognize our team members.



Charley Brough Branch Manager



Charley Brough supervises landscape maintenance and enhancement activities in Longwood. His 25 year experience in the green and landscaping industry has made Charley a key member of the BrightView Team since 1998

EDUCATION

United States Marine Corp | 1994-1998

DUTIES

- Work closely with the account managers to review progress and efficiency of the properties under their supervision
- Optimize monthly budgets to be allocated in the different branch divisions and support services
- Develop weekly schedules for the maintenance teams and all support services
- Schedule weekly meetings to keep up to date with all branch activity
- Assure customer satisfaction by producing and sustaining an attractive landscape

CERTIFICATION AND TRAINING

- Best Management Practices | University of Florida
- MOT Certificate
- Florida Pest Limited Applicator License
- Account Manager Training Program
- BrightView Production Systems



1174 Central Florida
Parkway, Longwood FL
32750



(321) 388-3915



Charley.brough@brightview.com



<https://www.brightview.com/>

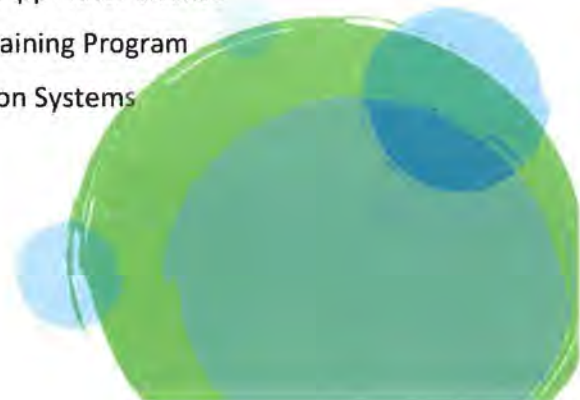



Jorge Ochoa

Account Manager

Jorge currently supervises landscape maintenance activities throughout your area. He has been in the landscape industry for 18 years and has been involved in project management, process improvement, maintenance, renovation, landscape design, installation, and tree care on all of his properties

EDUCATION

University of Maryland University College | Lake Arbor, Maryland | 2012

Bachelor Degree in Business

Montgomery College | Rockville, Maryland | 2012

Associate Degree in Landscaping Technology

DUTIES

- Work closely with production managers to review progress and work efficiency of the properties under their supervision
- Attend weekly meetings organized by branch manager to report progress and planning schedule
- Develop weekly schedules for production managers and crew leaders under their supervision
- Schedule site walks in order to assure customer satisfaction by producing and sustaining an attractive landscape
- Maximize beauty and quality in landscaping

CERTIFICATION AND TRAINING

- Lean Six Sigma Green Belt Certification
- MOT certificate
- Account Manager Training Program

 4777 Old Winter Garden Rd, Orlando, FL 32811

 (407) 257-1847

 jorge.ochoa@brightview.com

 <https://www.brightview.com/>



Our Key Service Plan Differences:

Innovative staffing - We all know that you get the best work more consistently and efficiently when a property trained team is doing it. Through our training and scheduling it allows us to ensure details are never missed, quality is consistently delivered and work can be scheduled around site conflicts or events.

An organized start to every day - We have a routine for starting the day to eliminate wasted time — so crews don't lose precious minutes or hours going to get fuel, an injury, a missing tool, or to fix broken equipment. Every day, before they leave the yard, your crews start with morning stretches, daily assignments, loading, inspections and equipment checks. These simple steps save time by eliminating unnecessary errands.

Reduced time and contract management – With our extensive design, development, installation and maintenance capabilities, you get a team that can deliver landscape solutions across the lifecycle of your property, minimizing time spent searching for, contracting and managing multiple, possibly untested providers.

Schedule Transparency – Keeping you well informed by providing detailed scheduling and updating you on any changes is part of our routine communication. You'll know when turf applications will be performed, irrigation inspections or repairs will be done and anything in between. Prior to the contract beginning during our initial job start up this detailed schedule will be provided.

Proactive Communication and Reporting

At BrightView we believe that ensuring open communication is our responsibility and we take a very conscious approach to making sure it happens at all times and all levels with your team. The Account Manager and your dedicated crew is empowered to be in charge, and ready to make things happen quickly. Our Branch Manager will also interact with you regularly to ensure that schedules are well coordinated and that your needs are being met.

You and the communities will receive quality site assessments (QSA's) on a routine basis. These inspections review turf quality, seasonal flowers, tree & shrub care, site quality and irrigation management. The assessments provide recommendations for property enhancements, note any maintenance items that need addressed and allow for additional reporting on property areas that may be outside of our scope work.



Our BrightView service plan is based on the desire to focus relentlessly on continuous improvement to ensure safety, quality and efficiency are always the result of the work we perform. Our model functions top down and bottom up allowing our leaders and crew members to create efficiency without cutting corners.

Quality Site Assessment

Property Name: Four Seasons at Historic Virginia
Date: Tuesday, September 24, 2019
Next Inspection Date:
Client Address:
BrightView Account #: 10761110

Community Common Area: entrance

Observations:

- 1) Suggested to remove the 2" x 2" x 1" of turf in the entrance area.
- 2) Suggested to evaluate and treat the trees in the courtyard area with a liquid or the entrance area. The trees need to be treated for gloomy cone.
- 3) Suggested to remove the turfs that have rotted. They are too dark and are having a lot of soil loss. We'll need to re-lay turfs in the courtyard area.
- 4) The special slope should be removed and replaced with a plant that won't erode on the turf. **Carex** line should spread into the turf if needed. Consider using a plant that won't erode on the turf of the ground cover.
- 5) Large beds need to be laid. Should need structural material to increase the appearance.

Work to be completed by:

- 1) Turf to be removed and re-laying to be completed in September.
- 2) Tree to be treated in month of October.
- 3) Plant material to be removed and replaced with new plants in early November.

Quality Site Assessment

Observation 1: Remove the turf areas in the courtyard area and re-lay.

Observation 2: Evaluate and treat the trees in the courtyard area with a liquid or the entrance area. The trees need to be treated for gloomy cone.

Observation 3: Remove the turfs that have rotted. They are too dark and are having a lot of soil loss. We'll need to re-lay turfs in the courtyard area.

Observation 4: The special slope should be removed and replaced with a plant that won't erode on the turf. **Carex** line should spread into the turf if needed. Consider using a plant that won't erode on the turf of the ground cover.

A Custom Color Program for Your Brand and Budget

On a per-square-foot basis, color plantings are usually the most intensively managed element of a landscape. There are ways, however, to develop an outstanding color program that makes a strong return on the investment. Color themes may be used to complement buildings, company colors or the appropriate season of the year. The number of potentially successful color schemes are many, but we'll put together a proposal based on your input— and deliver a customized, cost-effective plan that's uniquely yours.

With careful planning, we can offer Central Park a well-designed and maintained seasonal color display that:

- Creates aesthetic excitement
- Provides an individual identity to the property
- Attracts the attention of tenants, residents, employees, guests and the general public
- Complements a well-maintained landscape
- Creates a pleasing atmosphere
- Makes an eye-catching statement
- Adds value to the property



Protecting Your Trees One of Your Most Important Investments

You can count on us to preserve your trees, enhance their appearance, increase their production, improve safety and reduce liability – all to protect one of your most important investments in the City. Our ISA Certified Arborist offer a comprehensive set of services and will be available to you for everything you may need to keep your trees healthy and beautiful. Tree Care services include:

- Tree pruning
- Soil and tissue analysis
- Annual and 3-5-year budget planning
- Cabling and bracing
- Emergency storm clearance
- Tree removal and stump grinding
- Inventory and management plans
- Insect and disease control
- Nutrient management
- Fertilization
- Transplant and relocation
- Nuisance fruit production control
- Hazard evaluation and management



BrightView Your E-Verified Employer

- Ensure 100% compliance with all labor and immigration laws we are enrolled in E-Verify in all states in which we operate.
- The organization's participation in E-Verify improves our ability to ensure the individuals we hire and are working on our client's sites are authorized to work in the United States.
- Additionally, E-Verify is only part of our robust employment verification program. The program includes a consistent policy and process enterprise-wide, as well as regular training of our staff and semi-annual auditing to maintain compliance with labor and immigration regulations.



E-Verify



U.S. Citizenship
and Immigration
Services

Human Resources, Benefits and Recruitment

HUMAN RESOURCE POLICIES

As one of the nation's largest landscape management firms, BrightView complies with all State & Federal Regulations. Our corporate Human Resources Department is responsible for supporting all of our branches with all compliance requirements. Included in these responsibilities is the enforcement of Equal Employment Opportunity, Sexual Harassment, and Alcohol & Drug policies. Our "800" Employee Hotline is administered by Human Resources as well.

EQUAL EMPLOYMENT OPPORTUNITY POLICY

It is the policy of the Company to select, develop, and promote employees based on individual ability and job performance. It has been, and shall continue to be, the policy of this Company to provide equal employment to all people regardless of race, color, religion, sex, sexual orientation, national origin, ancestry, pregnancy, marital status, age, and disability. This policy affects decisions including, but not limited to, an employee's compensation, benefits, terms and conditions of employment, opportunities for promotion, training and development, transfer, and other privileges of employment. It has been, and shall continue to be, the Company's policy to maintain a working environment free of sexual harassment and intimidation. Further, it is the policy of the Company to comply with the letter and spirit of applicable local, state and federal statutes concerning equal employment opportunity.

SEXUAL HARASSMENT

It is the Company policy that all employees should be able to enjoy a work atmosphere free of all forms of discrimination, including sexual harassment.

Sexual harassment does not mean occasional compliments of a socially acceptable nature. Sexual harassment refers to conduct which is offensive to the individual, which harms morale, creates a hostile environment, or which interferes with the effectiveness of our business. No employee, male or female, should be subjected to unsolicited and unwelcome sexual overtures, either verbally or physically. This type of conduct is strictly prohibited.

Any employee who feels he or she is a victim of sexual harassment, or has knowledge of that kind of behavior, should report such conduct immediately to their supervisor or Human Resources. During the investigation phase, the complaint will be kept confidential. Following a thorough investigation, the Company will take immediate



disciplinary action against any employee engaging in sexual harassment. Such action may include reprimand, suspension, demotion, or discharge, depending upon the circumstances.

DRUG AND ALCOHOL TESTING PROGRAM

All individuals seeking employment with BrightView Landscape will be drug and alcohol tested as a condition of employment, regardless of the number of hours intended to work or the position held. Drug and alcohol testing is also required when an employee is involved in work-related accidents or injuries. If there is reasonable suspicion of use, employees may be subject to random testing and return to duty with follow up testing at a future date.

EMPLOYEE HOTLINE

If an employee has a question, concern, or problem about pay, working hours, or other personal matters, they may call the Employee Hotline. This tool is available if the employee is not comfortable discussing the matter with their Manager or if the matter has not been resolved to their liking.

Employees may also use the Hotline to report employee theft, drug possession or use, or other acts that detrimentally affect the safe and efficient operation of the Company.

The Hotline offers employees a private direct line to the Human Resources Department and Senior Corporate Management. Employees may call 24 hours a day, 7 days a week anonymously and without penalty.

A Safe Community and Workplace is Our Priority

Safety is our top priority at BrightView and we are committed to keeping our people safe every day across our business. As an organization committed to constant improvement, we actively work to continue developing a best-in-class Safety Management System that results in zero injuries to our team members. We take pride in conducting our business operations in a manner that helps to ensure the safety and well-being of our team members, customers, and the properties in which we operate.

We believe in the following principles:

Safety is our top priority

Appropriate PPE must be worn

Follow-up, report, and learn from incidents

Everyone is responsible for each other

Training is the first step to safe behavior

You are the key to making a difference



BrightView's management is committed to providing a safe work environment and establishing safe work practices for all our employees. We begin all new jobs with a safety inspection. This identifies any job site hazards, roadway hazards and the safest place to operate from onsite. Trucks are always equipped with cones that are placed around the truck and trailer at all times. We also demonstrate this commitment to safety through a continuing program of education and training, accident prevention, reporting, investigation and analysis, and the development of positive attitudes about safety and awareness about safety by all employees.



The following can be provided upon request:

- Safety Manual
- OSHA Compliance Manual
- Right to Know Program
- Safety Rules and Regulations
- HAZCOM Policy
- Safety Compliance Checklists
- Crew Member Equipment Safety Training Program
- Weekly Safety Talks

Emergency Response Team Ready When You Need Us

Every property is different and thus has a unique set of maintenance needs. We have evaluated the facilities and taken into consideration the issues you identified. Creating the maintenance plan below designed to keep your property looking its best year-round.

With hundreds of locations, we can dispatch faster than other landscape service providers in the event of a catastrophic situation, including but not limited to hurricanes, tornadoes / water spouts, and severe weather.

When a catastrophe occurs, your local Branch Manager Charley Brough will personally draw on resources and pull equipment from within the BrightView network to ensure your property is quickly, properly and safely serviced.

Resources from branch offices will be available in the event of an emergency to ensure our customers have access to crews and equipment quickly.



STATE OF FLORIDA
Department of Agriculture and Consumer Services
BUREAU OF LICENSING AND ENFORCEMENT

Date
May 30, 2019

File No.
JF206207

Expires
June 1, 2020

THE CERTIFIED PEST CONTROL OPERATOR NAMED BELOW HAS REGISTERED UNDER THE PROVISIONS OF CHAPTER 482 FOR THE PERIOD EXPIRING: **June 1, 2020**

DUSTIN MAFFIOLI
1064 CHELTANHAM CT
LONGWOOD, FL 32750

Lawn and Ornamental

Nicole Fried

NICOLE "NIKKI" FRIED, COMMISSIONER



This Certifies that
Charley E. Brough Jr.

Has Completed a Florida Department of Transportation Approved
Temporary Traffic Control (TTC) Advanced Course.

Date Expires: 06/08/2022

Certificate # 40912

Instructor: Jack Luckhardt

FDOT Provider # 110

Safety Links
Phone: 800-768-7036
1855 W State Rd 434 Ste. 281
Longwood, FL 32750
www.safetylinks.net
ghansen@safetylinks.net





RICK SCOTT, GOVERNOR

JONATHAN ZACHEM, SECRETARY



**STATE OF FLORIDA
DEPARTMENT OF BUSINESS AND PROFESSIONAL REGULATION**

CONSTRUCTION INDUSTRY LICENSING BOARD

THE PLUMBING CONTRACTOR HEREIN IS CERTIFIED UNDER THE
PROVISIONS OF CHAPTER 489, FLORIDA STATUTES

VICTORIA, CARLOS M

BRIGHTVIEW LANDSCAPE SERVICES, INC.
4155 EAST MOWRY DRIVE
HOMESTEAD FL 33033

LICENSE NUMBER: CFC1429383

EXPIRATION DATE: AUGUST 31, 2020

Always verify licenses online at MyFloridaLicense.com



Do not alter this document in any form.

This is your license. It is unlawful for anyone other than the licensee to use this document.

INTERNATIONAL SOCIETY OF ARBORICULTURE
CERTIFIED ARBORIST™

Jason Mahle

Having successfully completed the requirements set by the
International Society of Arboriculture, the above named
is hereby recognized as an ISA Certified Arborist®



Luana Vargas
Director of Credentialing Services
International Society of Arboriculture

Caitlyn Polifhan
Executive Director
International Society of Arboriculture

FL-9483A
Certification Number

22 Mar 2019
Certified Since

30 Jun 2022
Expiration Date



#0847
ISO/IEC 17024
Personnel Certification Program
ISA Certified Arborist*

BUSINESS TAX RECEIPT

CITY OF LONGWOOD
175 W WARREN AVE
LONGWOOD, FL 32750

2019-2020

Phone: (407)260-3442
<http://www.longwoodfl.org>

Receipt #: 20-00065

Issued Date: 09/13/19

Effective Date: 10/01/19

Expiration Date: 09/30/20

License Type: SUBCONTRACTORS/OVER 30 EMP

Business Name: BRIGHTVIEW LANDSCAPE SERVICES

Business Location: 1174 FLORIDA CENTRAL PKWY

VICKY HARRIS
980 JOLLY RD
STE 300
BLUE BELL, PA 19422





FINANCE DIRECTOR:

RECEIPT MUST BE CONSPICUOUSLY DISPLAYED AT BUSINESS LOCATION.

BRIGHTVIEW LANDSCAPE SERVICES
VICKY HARRIS
980 JOLLY RD
STE 300
BLUE BELL, PA 19422



PRICING

Proposal Form



PACKAGE # 1

Respondent Name (Company): BrightView Landscape Services

Name and Title of Person Completing Form: Charley Brough Associate Branch Manager

PROPOSED COST

Base Maintenance	\$ 5,635.00/month
Palm Trimming Greater than 13' OA (per tree)	\$ 35.00
Crepe Trimming Greater than 13' OA (per tree)	\$ 55.00
Irrigation Inspections	\$ 900.00/month
Mulch- Supplied and Installed (per cubic yard)	\$ 50
Fertilizer (per application)	\$ 1,353.00
Integrated Pest Management (per application)	\$ 2,070.00
PROPOSAL TOTAL	\$ 10,098.00

PLANT, TREE, AND GROUND COVER INSTALLATION

Not to be included as part of proposal review criteria. Price to include all components of installation including staking, watering in, and one-year warranty.

Annuals (Cost plus %)	185	%
Ground cover (Cost plus %)	250	%
Shrubs (Cost plus %)	250	%
Palms (Cost plus %)	250	%
Canopy trees (Cost plus %)	250	%
Understory trees (Cost plus %)	250	%
Sod (Cost plus %)	200	%

Proposal Form (Continued)



PACKAGE # 1

TREE REMOVAL AND STUMP GRINDING

Not to be included as part of the proposal review criteria. Price to include back fill/sod if needed.

Tree removal 6"	\$ 600.00
Tree removal 12"	\$ 1,200.00
Tree removal 18"	\$ 1,800.00
Tree removal 24"	\$ 2,400.00
Tree removal 36"	\$ 3,600.00

IRRIGATION REPAIR

Not to be included as part of proposal review criteria unless otherwise noted.

Wholesale price of materials plus proposed percentage	150	%
Irrigation Technician Hourly Rate	\$ 50.00	

Signature of person completing form: _____

Proposal Form



PACKAGE # 2

Respondent Name (Company): BrightView Landscape Services

Name and Title of Person Completing Form: Charley Brough Associate Branch Manager

PROPOSED COST

Base Maintenance	\$ 17,973.00/month
Palm Trimming Greater than 13' OA (per tree)	\$ 35.00
Crepe Trimming Greater than 13' OA (per tree)	\$ 55.00
Irrigation Inspections	\$ 900.00/month
Mulch- Supplied and Installed (per cubic yard)	\$ 50
Fertilizer (per application)	\$ 4,314.00
Integrated Pest Management (per application)	\$ 6,676.00
PROPOSAL TOTAL	\$ 30,003.00

PLANT, TREE, AND GROUND COVER INSTALLATION

Not to be included as part of proposal review criteria. Price to include all components of installation including staking, watering in, and one-year warranty.

Annuals (Cost plus %)	185	%
Ground cover (Cost plus %)	250	%
Shrubs (Cost plus %)	250	%
Palms (Cost plus %)	250	%
Canopy trees (Cost plus %)	250	%
Understory trees (Cost plus %)	250	%
Sod (Cost plus %)	200	%

Proposal Form (Continued)



PACKAGE # 2

TREE REMOVAL AND STUMP GRINDING

Not to be included as part of the proposal review criteria. Price to include back fill/sod if needed.

Tree removal 6"	\$ 600.00
Tree removal 12"	\$ 1,200.00
Tree removal 18"	\$ 1,800.00
Tree removal 24"	\$ 2,400.00
Tree removal 36"	\$ 3,600.00

IRRIGATION REPAIR

Not to be included as part of proposal review criteria unless otherwise noted.

Wholesale price of materials plus proposed percentage	150	%
Irrigation Technician Hourly Rate	\$ 50.00	

Signature of person completing form: _____

Proposal Form



PACKAGE # 3

Respondent Name (Company): BrightView Landscape Services

Name and Title of Person Completing Form: Charley Brough Associate Branch Manager

PROPOSED COST

Base Maintenance	\$ 26,775.00/month
Palm Trimming Greater than 13' OA (per tree)	\$ 35.00
Crepe Trimming Greater than 13' OA (per tree)	\$ 55.00
Irrigation Inspections	\$ 900.00/month
Mulch- Supplied and Installed (per cubic yard)	\$ 50
Fertilizer (per application)	\$ 6,426.00
Integrated Pest Management (per application)	\$ 1,912.00
PROPOSAL TOTAL	\$ 36,153.00

PLANT, TREE, AND GROUND COVER INSTALLATION

Not to be included as part of proposal review criteria. Price to include all components of installation including staking, watering in, and one-year warranty.

Annuals (Cost plus %)	185	%
Ground cover (Cost plus %)	250	%
Shrubs (Cost plus %)	250	%
Palms (Cost plus %)	250	%
Canopy trees (Cost plus %)	250	%
Understory trees (Cost plus %)	250	%
Sod (Cost plus %)	200	%

Proposal Form (Continued)



PACKAGE # 3

TREE REMOVAL AND STUMP GRINDING

Not to be included as part of the proposal review criteria. Price to include back fill/sod if needed.

Tree removal 6"	\$ 600.00
Tree removal 12"	\$ 1,200.00
Tree removal 18"	\$ 1,800.00
Tree removal 24"	\$ 2,400.00
Tree removal 36"	\$ 3,600.00

IRRIGATION REPAIR

Not to be included as part of proposal review criteria unless otherwise noted.

Wholesale price of materials plus proposed percentage	150	%
Irrigation Technician Hourly Rate	\$ 50.00	

Signature of person completing form: _____

Proposal Form



PACKAGE # 4

Respondent Name (Company): BrightView Landscape Services

Name and Title of Person Completing Form: Charley Brough Associate Branch Manager

PROPOSED COST

Base Maintenance	\$ 4,480.00/month
Palm Trimming Greater than 13' OA (per tree)	\$ 35.00
Crepe Trimming Greater than 13' OA (per tree)	\$ 55.00
Irrigation Inspections	\$ 200.00/month
Mulch- Supplied and Installed (per cubic yard)	\$ 50
Fertilizer (per application)	\$ 1,076.00
Integrated Pest Management (per application)	\$ 1,664.00
PROPOSAL TOTAL	\$ 7,560.00

PLANT, TREE, AND GROUND COVER INSTALLATION

Not to be included as part of proposal review criteria. Price to include all components of installation including staking, watering in, and one-year warranty.

Annuals (Cost plus %)	185	%
Ground cover (Cost plus %)	250	%
Shrubs (Cost plus %)	250	%
Palms (Cost plus %)	250	%
Canopy trees (Cost plus %)	250	%
Understory trees (Cost plus %)	250	%
Sod (Cost plus %)	200	%

Proposal Form (Continued)



PACKAGE # 4

TREE REMOVAL AND STUMP GRINDING

Not to be included as part of the proposal review criteria. Price to include back fill/sod if needed.

Tree removal 6"	\$ 600.00
Tree removal 12"	\$ 1,200.00
Tree removal 18"	\$ 1,800.00
Tree removal 24"	\$ 2,400.00
Tree removal 36"	\$ 3,600.00

IRRIGATION REPAIR

Not to be included as part of proposal review criteria unless otherwise noted.

Wholesale price of materials plus proposed percentage	150	%
Irrigation Technician Hourly Rate	\$ 50.00	

Signature of person completing form: _____

Proposal Form



PACKAGE # 5

Respondent Name (Company): BrightView Landscape Services

Name and Title of Person Completing Form: Charley Brough Associate Branch Manager

PROPOSED COST

Base Maintenance	\$	10,150.00/month
Palm Trimming Greater than 13' OA (per tree)	\$	35.00
Crepe Trimming Greater than 13' OA (per tree)	\$	55.00
Irrigation Inspections	\$	1,121.00/month
Mulch- Supplied and Installed (per cubic yard)	\$	50
Fertilizer (per application)	\$	2,436.00
Integrated Pest Management (per application)	\$	1,011.00
PROPOSAL TOTAL	\$	14,858.00

PLANT, TREE, AND GROUND COVER INSTALLATION

Not to be included as part of proposal review criteria. Price to include all components of installation including staking, watering in, and one-year warranty.

Annuals (Cost plus %)	185	%
Ground cover (Cost plus %)	250	%
Shrubs (Cost plus %)	250	%
Palms (Cost plus %)	250	%
Canopy trees (Cost plus %)	250	%
Understory trees (Cost plus %)	250	%
Sod (Cost plus %)	200	%

Proposal Form (Continued)



PACKAGE # 5

TREE REMOVAL AND STUMP GRINDING

Not to be included as part of the proposal review criteria. Price to include back fill/sod if needed.

Tree removal 6"	\$ 600.00
Tree removal 12"	\$ 1,200.00
Tree removal 18"	\$ 1,800.00
Tree removal 24"	\$ 2,400.00
Tree removal 36"	\$ 3,600.00

IRRIGATION REPAIR

Not to be included as part of proposal review criteria unless otherwise noted.

Wholesale price of materials plus proposed percentage	150	%
Irrigation Technician Hourly Rate	\$ 50.00	

Signature of person completing form: _____

Proposal Form



PACKAGE # 6

Respondent Name (Company): BrightView Landscape Services

Name and Title of Person Completing Form: Charley Brough Associate Branch Manager

PROPOSED COST

Base Maintenance	\$ 7,242.00/month
Palm Trimming Greater than 13' OA (per tree)	\$ 35.00
Crepe Trimming Greater than 13' OA (per tree)	\$ 55.00
Irrigation Inspections	\$ 975.00/month
Mulch- Supplied and Installed (per cubic yard)	\$ 50
Fertilizer (per application)	\$ 1,738.00
Integrated Pest Management (per application)	\$ 1,097.00
PROPOSAL TOTAL	\$ 11,192.00

PLANT, TREE, AND GROUND COVER INSTALLATION

Not to be included as part of proposal review criteria. Price to include all components of installation including staking, watering in, and one-year warranty.

Annuals (Cost plus %)	185	%
Ground cover (Cost plus %)	250	%
Shrubs (Cost plus %)	250	%
Palms (Cost plus %)	250	%
Canopy trees (Cost plus %)	250	%
Understory trees (Cost plus %)	250	%
Sod (Cost plus %)	200	%

Proposal Form (Continued)



PACKAGE # 6

TREE REMOVAL AND STUMP GRINDING

Not to be included as part of the proposal review criteria. Price to include back fill/sod if needed.

Tree removal 6"	\$ 600.00
Tree removal 12"	\$ 1,200.00
Tree removal 18"	\$ 1,800.00
Tree removal 24"	\$ 2,400.00
Tree removal 36"	\$ 3,600.00

IRRIGATION REPAIR

Not to be included as part of proposal review criteria unless otherwise noted.

Wholesale price of materials plus proposed percentage	150	%
Irrigation Technician Hourly Rate	\$ 50.00	

Signature of person completing form: _____

Proposal Form



PACKAGE # 7

Respondent Name (Company): BrightView Landscape Services

Name and Title of Person Completing Form: Charley Brough Associate Branch Manager

PROPOSED COST

Base Maintenance	\$ 33,880.00/month
Palm Trimming Greater than 13' OA (per tree)	\$ 35.00
Crepe Trimming Greater than 13' OA (per tree)	\$ 55.00
Irrigation Inspections	\$ 875.00/month
Mulch- Supplied and Installed (per cubic yard)	\$ 50
Fertilizer (per application)	\$ 8,132.00
Integrated Pest Management (per application)	\$ 1,875.00
PROPOSAL TOTAL	\$ 44,902.00

PLANT, TREE, AND GROUND COVER INSTALLATION

Not to be included as part of proposal review criteria. Price to include all components of installation including staking, watering in, and one-year warranty.

Annuals (Cost plus %)	185	%
Ground cover (Cost plus %)	250	%
Shrubs (Cost plus %)	250	%
Palms (Cost plus %)	250	%
Canopy trees (Cost plus %)	250	%
Understory trees (Cost plus %)	250	%
Sod (Cost plus %)	200	%

Proposal Form (Continued)



PACKAGE # 7

TREE REMOVAL AND STUMP GRINDING

Not to be included as part of the proposal review criteria. Price to include back fill/sod if needed.

Tree removal 6"	\$ 600.00
Tree removal 12"	\$ 1,200.00
Tree removal 18"	\$ 1,800.00
Tree removal 24"	\$ 2,400.00
Tree removal 36"	\$ 3,600.00

IRRIGATION REPAIR

Not to be included as part of proposal review criteria unless otherwise noted.

Wholesale price of materials plus proposed percentage	150	%
Irrigation Technician Hourly Rate	\$ 50.00	

Signature of person completing form: _____

SECTION 00700 – DRUG FREE WORKPLACE FORM

The undersigned proposer, in accordance with Florida Statute 287.087 hereby certifies that BrightView Landscape Services does:

(Name of Business)

1. Publish a statement notifying employees that the unlawful manufacture, distribution, dispensing, possession or use of a controlled substance is prohibited in the workplace and specifying the actions that will be taken against employees for violations of such prohibition.
2. Inform employees about the dangers of drug abuse in the workplace, the business's policy of maintaining a drug-free workplace, any available drug counseling, rehabilitation, and employee assistance programs, and the penalties that may be imposed upon employees for drug abuse violations.
3. Give each employee engaged in providing the commodities or contractual services that are under contract a copy of the Drug-Free statement.
4. Notify the employees that as a condition of working on the commodities or contractual services that are under contract, employee will abide by the terms of the statement and will notify the employer of any conviction of, or plea of guilty or nolo contendere to, any violation of Chapter 893 or of any controlled substance law of the United States or any state, for a violation occurring in the workplace no later than five (5) days after such conviction.
5. Impose a sanction on, or require the satisfactory participation in a drug abuse assistance or rehabilitation program if such is available in the employee's community, by any employee who is so convicted.
6. Make a good faith effort to continue to maintain a drug-free workplace through implementation of this section.

As the person authorized to sign the statement, I certify that this business complies fully with the above requirements.



(Authorized signature)

10/23/19

(Date)

Charley Brough

(Print/type name as signed above)

****THIS FORM MUST BE COMPLETED AND RETURNED WITH YOUR SUBMITTAL.**

NON-COLLUSION AFFIDAVIT OF PRIME RESPONDENT

STATE OF Florida)

COUNTY OF Seminole)

Terry Cordes, being duly sworn, deposes and says that:

(1) He/she is Business Developer of BrightView Landscape Services, LLC
Title Firm/Company

the respondent that has submitted the attached response.

- (2) He/she is fully informed respecting the preparation and contents of the attached solicitation and of all pertinent circumstances respecting such solicitation.
- (3) Such solicitation is genuine and is not a collusive or sham solicitation.
- (4) Neither the said respondent nor any of its officers, partners, owners, agent representatives, employees or parties in interest including this affiant, has in any way, colluded, conspired, or agreed, directly or indirectly, with any other respondent, firm or person, to submit a collusive or sham response in connection with the Agreement for which the attached response has been submitted or to refrain from proposing in connection with such Agreement, or has in any manner, directly or indirectly, sought by Agreement or collusion or communication or conference with any other responder, firm or person to fix the price or prices in the attached solicitation or of any other respondent, or to fix any overhead, profit or cost element of the proposed price or the proposed price of any other responder, or to secure through any collusion, conspiracy, connivance or unlawful Agreement any advantage against the City of Winter Springs, Florida, or any person interested in the proposed Agreement.
- (5) The price or prices quoted in the attached response are fair and proper and are not tainted by any collusion, conspiracy, or unlawful Agreement on the part of the proposer or any of its agents, representatives, owners, employees, or parties of interest, including affiant.

[Signature]
(Signed)
Business Developer
(Title)

STATE OF FLORIDA
COUNTY OF SEMINOLE

The foregoing instrument was acknowledged before me this October 22, 2019 by Terry Cordes who is personally known to me or who has produced FL drivers license as identification and who did (did not) take an oath.

[Signature] (Signature of Notary Public)
Kulsum Lakha (Name of Notary Typed, Printed or Stamped)
Notary Public
6932649 (Commission Number)

Kulsum Lakha
Notary Public
State of Florida
My Commission Expires 9/22/2020
Commission No. GG 32649

****THIS FORM MUST BE COMPLETED AND RETURNED WITH YOUR SUBMITTAL.**

Thirty (30) days cancellation notice required.

The undersigned firm agrees to obtain, prior to award, if selected, insurance as stated above.

BrightView Landscape Services/Charley Brough

PROPOSER/BIDDER

AUTHORIZED SIGNATURE
Associate Branch Manager

OFFICER TITLE
10/23/19

DATE

****THIS FORM MUST BE COMPLETED AND RETURNED WITH YOUR SUBMITTAL.**

Successful BrightView Partnerships

Reference #1

Client Name: Seminole County Roadways Contact Name: Bill Pandal
City State: Sanford, FL Phone# 407-665-2176 Fax# 407-665-2179
Email: BillPandal@seminolecount.fl.gov
Products/Services Provided: mowing, edging, trash removal, shrub trimming, fertilization, irrigation repair & maintenance of Medians & ROW
Date(s) 1/10 2007- Present

Reference #2

Client Name: Baldwin Park Contact Name: Stacey Fryrear
City State: Orlando, FL Phone# 407-740-5838 Fax# 407-740-0712
Email: sfryrear@sentrymgmt.com
Products Services Provided: Full Landscape & Irrigation Services to Residential Owners Assn. & Commercial Assn. / Urban Community Development
Date(s) 7/1 2004 Present

Reference #3

Client Name: City of Ocoee Contact Name: Vito Petrone
City State: Ocoee, FL Phone# 407-470-6471 Fax# 407-905-3194
Email: VitoPetrone@ocoee.org
Products Services Provided: Maintenance of Roadways, Medians, ROW, facilities & misc. sites in the City of Ocoee
Date(s) 10/1 2006- Present

Reference #5

Client Name: Seminole County Lawn Maintenance for Parks and Boat Ramps Contact Name: Bill Pandal
City State: Sanford, FL Phone# 407-665-2176 Fax# 407-665-2179
Email: wpandal@seminolecount.fl.gov
Products Services Provided: Maintenance of Active and Passive parks & Boat Ramps throughout Seminole County
Date(s) 2/22 2012- Present

Reference #6

Client Name: Seminole County Lawn Maintenance for Large Facilities Contact Name: Bill Pandal
City State: Sanford, FL Phone# 407-665-2176 Fax# 407-665-2179
Email: wpandal@seminolecount.fl.gov
Products Services Provided: Maintenance of Large Facilities throughout Seminole County Date(s) 6/1 2019- Present

City of Winter Springs

Landscape Maintenance Proposal

RFP 07-19 KM

Proposal Checklist

A. ✓

B. ✓

C. ✓

D. ✓

E. ✓

F. ✓

G. ✓

H. ✓

Landscape Maintenance Services Proposal

prepared for

October 2019

City of Winter Springs



YELLOWSTONE
LANDSCAPE



407.814.2400 tel
407.396.2023 fax

1930 Silver Star Rd.
Orlando, FL 32804
www.yellowstonelandscape.com

October 23rd, 2019

Kevin Maddox
City of Winter Springs
1126 S.R 434
Winter Springs, FL 32708
407-327-8957

Re: Landscape Maintenance Services Proposal for The City of Winter Springs

Dear Kevin,

Thank you for considering a partnership with Yellowstone Landscape as your landscape maintenance service provider. Our proposal has been created to address the specific needs and expectations you have expressed for **The City of Winter Springs**. We call this your Plan for Success because our integrated service plan has been designed to give you a landscape that you can be proud of.

Your Plan for Success includes the following sections:

- **Summary of Observation & Startup Plan:** Actions we will take in the first 30, 60 and 90 days of service to improve both your specific areas of concern and your landscape's overall appearance.
- **Scope of Services:** Summarizes our proposed scope of services, detailing the best practices we've developed to provide a consistent appearance across your landscape.
- **About Us:** Information about our company's qualifications, capabilities and values. Selected listing of clients who manage properties with landscape needs similar in scope to yours. Please reach out to them with any questions you have about our firm.
- **Licenses and Certifications:** All current licenses and certifications held by our local staff.
- **Your Investment:** Our service agreement and pricing for the services we'll provide to your property. Also includes other required RFP documents and signature page.

If you have any questions after reviewing our proposal, please contact me at any time. I would welcome the opportunity to provide you any further details about our firm's commitment to delivering a landscape that you will be proud of.

Sincerely,

Landon Pyle
Business Development Manager
Lpyle@yellowstonelandscape.com
407.625.7822



407.396.0529 tel
407.396.2023 fax

1930 Silver Star Road
Orlando, FL 32804

www.yellowstonelandscape.com

October 22, 2019

Kevin Maddox
Landscape Manager
City of Winter Springs
1126 East State Rd
Winter Springs, FL 32708
Ph. 407-327-8957
rmaddox@winterspringsfl.org

Re: Approach to Landscape Maintenance Services for City of Winter Springs

Dear Mr. Maddox,

In the following document we will break down our landscape approach to services for City of Winter Springs. We want you to understand how our crews work, who is responsible for what within our company, and how we will service all the sections identified within the RFP. Yellowstone Landscape's extensive experience in production planning allows our teams to develop a program that will ensure that all tasks outlined in the RFP will be performed timely and consistently. All of the tasks and teams will be managed by our account manager who will be your main point of contact within Yellowstone Landscape. This account manager will make sure outstanding quality and customer service are delivered to you and residents utilizing these facilities, parks, and roadways. You will see in our references that we have a lot of experience in maintaining this type of work for several cities and counties throughout Central Florida and we urge you to reach out and speak with the contacts listed. We want you to feel more than confident when making your decision and feel comfortable that you have chosen a company with an incredible track record and one that is more than capable to enhance your beautiful landscape.

1. Project Approach Breakdown

- a. Mow/detail team – Multiple crews that will fluctuate in size from 2-6 people depending on the properties they will be visiting and the time of the year. All properties will be serviced on Monday through Friday between 7:30 am and 5pm. Our teams will plan on tackling public facilities prior to 9am during weekdays especially in immediate areas around buildings. Once facilities are open, we will move our maintenance teams to areas away from buildings so not to disturb visitors or employees. All roadway maintenance areas will be serviced in a way where safety of our employees and residents are of utmost importance. MOT signs will be utilized to let commuters know where our teams are working by breaking roadway areas into smaller sections. We will finish a section of medians and ROWs and then move onto

next section in sequence. A well sequenced plan will ensure our success on these properties.

i. Mowing

1. Edging, mowing, string trimming, and blowing off all turf and hardscape areas
 - a. 52" walk behind mowers and 60" riding mowers will be utilized to perform mowing functions.
 - b. Mechanical edging of all areas where turf meets hardscape will be done weekly during growing season and bi-weekly during slower season.
 - c. All areas requiring string trimming will be done with each mow.
 - d. All areas will be blown off with each mow.
 - e. Litter removal will be done on each visit.

ii. Detail/Pruning/Weed Control

1. Hand-pruning and shearing will be done as to prune all areas monthly. We will break down areas into sections where we prune a section each week with the intention of completing a full rotation 1x per month.
2. Crape Myrtle Pruning when requested.
3. Hand-pulling of weeds.
4. Non-selective weed control with round-up.
 - a. All of our account managers, crew leaders, and crew leads have spray licenses and have gone through training to perform these functions.
5. Pre-emergents will be used in bed areas to help prevent future weed seedlings from germinating.
6. Pruning of palms will be done when requested.
7. Elevation pruning will be performed on all hardwood trees to they don't interfere with pedestrians or vehicles. Up to 13'.
8. Cutbacks of plant material (grasses will be routinely trimmed away from parking spaces, sidewalks, and roadways. Will perform a hard cutback 1x per year.
9. Blowing off property after trimming.
10. Leaf and acorn removal.
11. Litter removal.
12. Mulch to be installed when requested.
13. Annuals to be installed when requested

b. Account manager

- i. Supervising and overseeing all aspects of maintenance by our crew members
- ii. Main point of contact for City of Winter Springs to communicate with
- iii. Will communicate any issues with the property and any scheduling conflicts.
 1. We are utilizing a tool called Site Audit which we can take pictures, make notes, and assign tasks to specific people within our company. It has been a highly effective tool and our customers are raving how much this improves communication and takes a pro-active approach.
 2. Account managers meet weekly with our branch manager to go over scheduling and adjustments that may be needed. We work together as a

- team to make sure our customers receive the best service and our crews stay on task.
3. Will make recommendations for fertilization and pest control treatments pro-actively and will also communicate when any pest issues arise that need addressed immediately
- iv. Will provide weekly checklist of maintenance activities completed.
 - v. Will communicate any irrigation issues witnessed out in the field back to City Manager.
- c. Fert/Disease/Pest Control
- i. Our approach to pest and disease control will be proactive and preventative. We will apply pre-emergents for known pests, such as funguses, to ensure the landscape is healthy and we are not reacting to known diseases. We will do inspections on all plant material and look for any signs of insects or fungus and treat for any problems we find to ensure the landscapes are kept in a pristine condition. Pest Managers will also be responsible for walking the site and making notes on any items to address and doing reports for the City on any chemical or fertilizer treatments. These treatments are not included in our base maintenance, but we will certainly communicate any issues we see throughout the year and make recommendations.
- d. Irrigation Management
- i. Irrigation inspections will be performed when requested by the City, but our account manager and team members will always be on the look out for hot spots/dry areas, irrigation breaks, and any other issues present so we can communicate them back to the City.
 - ii. It will be important to do a full audit of irrigation systems where present to determine deficiencies and opportunities to provide better coverage to landscape. We are always looking for ways to improve systems and reduce water usage.

Please let us know if you have any questions about our scope of services or landscape approach. We are very excited about the potential opportunity to beautify your properties!

Sincerely,

Josh Cochran
Branch Manager
jcochran@yellowstonelandscape.com
407-396-0529

Sec. 10-137. - At-home sales.



- (a) Sales on residential property of new or used goods, wares, or merchandise, generally outdoors, and known variously as carport, garage, yard, sidewalk, attic, basement, rummage, tent, estate sales, or any similar sales, shall be held only after a permit for such sale is obtained from the city building department. Such sales on residential property shall be held only by the resident(s) of the property and shall be of no longer duration than six (6) days total for each sale. No more than two (2) such sales shall be held during any twelve-month period by any person or organization. No retail or wholesale merchant shall hold any such sale on residential property.
- (b) A fee established by resolution of the city shall be charged for the permit required to hold the sale and to post signs advertising the sale on the property on which the sale is held. A portion of the fee may be refunded if all signs noticing the sale are removed from the site of the sale within five (5) days after the sale.

(Code 1974, § 8-2)



YELLOWSTONE
LANDSCAPE

Start-up Plan

Startup Plan



This checklist is provided as an outline of the initial tasks that our Landscape Maintenance teams will perform as we begin serving. We've divided the tasks over the first 30, 60, and 90 days of service in order to provide you with a tool to monitor and measure our team's performance as we begin our partnership as your landscape maintenance service partner.

First 30 Days

- Meet with Property Manager to review 30 – 60 – 90 Day Plan
- Discuss with management our "Approach to Services" and "Service Map"
- Complete an irrigation audit of the entire system
- Present irrigation deficiencies with plan for corrections
- Begin maintenance – mowing, blowing and edging
- Spend significant amount of time cleaning up the areas that have been neglected (trimming of hedges, weed control, edging of beds, remove dead plant material, and clean up focal areas)
- Spot treat weeds in turf areas to be reclaimed
- Selective weed control to treat torpedo grass and other weeds within plant material
- Begin bed separation trimming in all planting beds
- Apply fertilizer to struggling shrubs on the property
- Begin insect and disease program on all plant material
- Discuss removing severely declining plant material
- Perform first turf fertilizer application
- Walk Property with Property Manager to identify other areas of concern
- Identify areas for improvement with Landscape Design Department.

Startup Plan



Days 31-60

- Walk property with Property Manager to evaluate improvements
- Evaluate our "Approach to Services" and make any necessary adjustments
- Continue irrigation maintenance and inspections
- Continue routine maintenance – mowing, blowing and edging
- Continue bed separation in all planting beds
- Retreat turf weeds
- Continue RoundUp applications throughout property
- Monitor and treat insect and disease problems in plant material throughout property
- Discuss options to improve "curb appeal" in high profile areas

Days 61-90

- Walk property with Property Manager to evaluate improvements
- Assess results from actions taken in 30 day and 60 day plans.
- Continue irrigation maintenance/inspections
- Continue turf weed applications as needed
- Continue RoundUp applications throughout property
- Monitor and treat insect and disease problems in plant material throughout property
- Continue routine maintenance – mowing, blowing and edging



City Of Winter Springs Site Audit

A handwritten signature in black ink that reads 'Landon Pyle'.

Landon Pyle

Yellowstone Landscape

Thursday, October 17, 2019

Prepared For City Of Winter Springs

24 Issues Identified



Issue

Ligustrum trees need tip Pruned
in center median

Assigned To

Comments



Issue

Replace damaged Schillings In
center median At Tuscora

Assigned To

Comments



Issue

Treat boxwoods and schillings

Insects/disease

Assigned To

Comments



Issue

Remove clippings after pruning
schillings

Assigned To

Comments



Issue

Remove Clippings

Assigned To

Comments



Issue

Remove Dead Boxwoods. Check For Improper Irrigation Coverage.

Assigned To

Comments



Issue

Remove Mulch From Base Of
Crepe Myrtles

Assigned To

Comments



Issue

Replace empty bed space with
new plant material

Assigned To

Comments



Issue

Recommend installing new plant material in center median on Moss Road

Assigned To

Comments



Issue

Remove fallen debris and treat weeds in center median on Moss Road

Assigned To

Comments

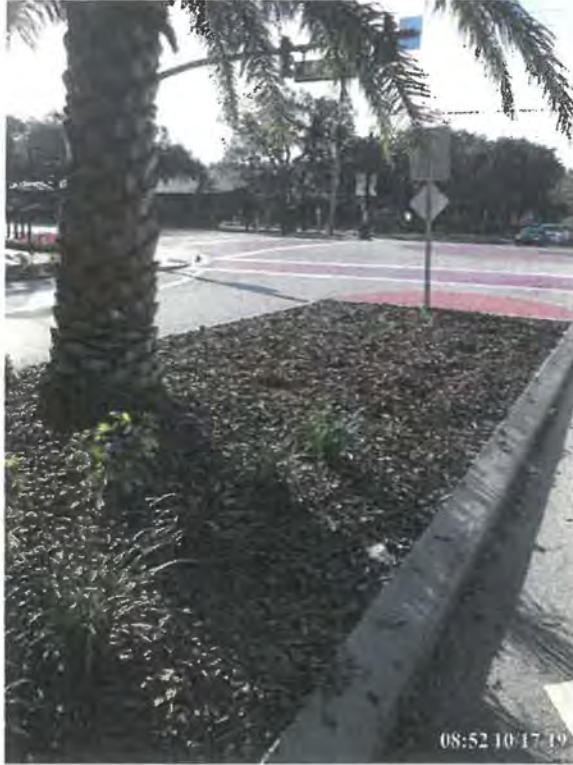

Issue

Recommend installing plant material in empty bed space at 434 and Moss Road

Assigned To

Comments



Issue

Recommend Removing Indian Hawthorne's At 434 And S. Devon Ave

Assigned To

Comments



Issue

Remove Dead Schillings On 434
R.O.W And S. Devon Ave

Assigned To

Comments



Issue

Remove Stump At 434 And S.
Devon Ave

Assigned To

Comments



Issue

Trash and litter needs to be cleaned up along 434 right away

Assigned To

Comments



Issue

Remove Dead Limbs From R.O.W On 434

Assigned To

Comments



Issue

Remove dead schillings At 434
& Edgemon Ave

Assigned To

Comments



Issue

Recommend adding plant
material and center median at
Tuscawilla Rd & 434

Assigned To

Comments



Issue

Remove sand build up at center median and install new plant material

Assigned To

Comments

Tuskawilla Rd & Forest Creek Dr



Issue

Spot Treat Weeds In Center Median At Tuskawilla Rd & Winter Springs Blvd

Assigned To

Comments



Issue

Add plant material in empty bed space At Tuskawilla Rd. & Winter Springs Blvd

Assigned To

Comments



Issue

Inspect Irrigation In Center Median On Winter Springs Blvd

Assigned To

Comments

Across from 7-Eleven



Issue

Inspect Irrigation In Center
Median At Winter Springs Blvd
& Arrowhead Ct

Assigned To

Comments



Issue

Remove Dead Palm In Center
Median On Winter Springs Blvd

Assigned To

Comments



YELLOWSTONE
LANDSCAPE

Scope of Work

V. **Definitions and Expectations for Maintenance Contract**

1) The definitions below describe the City's expectation for maintenance. These definitions are applicable to all packages; unless the package description states otherwise. Unless otherwise noted; costs for all services listed shall be considered part of the monthly maintenance and shall be included in the cost for monthly maintenance at each site.

A. Mowing/Turf Care

- i. Mowing of all grassed areas shall be no less than once every seven (7) days in the heavy growing season and shall be no less than bi-weekly, or as instructed by the City's Representative during the dormant growing season. Growing seasons are dictated by the weather and therefore may change per the City's Representative, but otherwise shall be:
 - a. Heavy Growing Season - March 15 through October 15
 - b. Dormant Growing Season - October 16 through March 14
- ii. Prior to mowing and trimming any turf and bed areas; paper bottles, cans and all other debris (as well as misplaced dirt or sand) must be removed from areas immediately bordering site (ex: sidewalks and curb lines) and actual site locations. Areas are to look clean and neat and free of debris at all times.
- iii. At no time shall more than one-third (1/3) of the leaf surface be removed in one mowing in any turf area unless specifically authorized in writing by the City of Winter Springs.
- iv. Turf care activities shall be scheduled during the normal work week (M-F 7:30am to Dusk unless directed otherwise) as a general rule and to allow for access to water plant facilities. Should field conditions occur that require a modification to the normal service schedule, Contractor must give the City 24 hours' notice and receive approval prior to a service schedule modification.
- v. Specific Turf Care
 - a. St. Augustine
 - i. Shall be in accordance with the University of Florida Cooperative Extension Services Calendar for St. Augustine sod care, culture, and good horticultural practice as shown in Publication ENH 5. St. Augustine grassed areas will be mowed to a height of 4.5" inches on average, depending upon established grass needs, by finish mower or a groom mower.
 - b. Bahia Grass
 - i. Shall be in accordance with the University of Florida Cooperative Extension Services Calendar for Bahia Grass sod care, culture, and good

horticultural practice as shown in Publication ENH 6. Bahia grassed areas will be mowed to a height of 3" inches on average, depending upon established grass needs, by finish mower or a groom mower.

c. Cutting of Native Grasses

- i. Contractor is to cut Native Grasses to no more than 50% of their length.
- ii. Contractor is to cut native grasses in late winter to early spring; just prior to new shoot growth.

B. Remove Grass Clippings and debris

- i. All debris (grass clippings) created by the mowing process is to be removed by mechanical means from all adjacent and contiguous surfaces following all landscaping activities.
- ii. Any clipping, trimming debris will be removed from site as work is completed, or at the end of each day that work is performed. Lawn clippings may be left on the turf areas so long as no readily visible clumps remain on the grass surface after mowing. Otherwise large clumps of clippings will be collected and disposed of by Contractor. In case of fungal disease outbreaks, all clipping will be collected and properly disposed of until disease is undetectable. No debris bags shall be left on site more than 6 hours.

C. Pruning/Trimming Shrubs, hedges, and ornamentals

- i. Pruning of plants shall be performed as directed to remove dead wood harboring insects and disease and to promote maximum health and growth. The finding of insects or disease shall be reported immediately to the City so as to limit losses. Aesthetic pruning shall consist of removal of dead or broken branches. Pruning shall be performed to balance infiltration light to enhance new growth.
- ii. Selective pruning shall be performed as directed to remove dead wood or moss. Trees shall be trimmed to maintain the required Department of Transportation clearance of 14' over the roadway. Suckers at the base of trees and branches hanging low into the median so as to impede a lawn mower shall be removed as regular maintenance; buck horning is not permitted unless requested by the City.
- iii. Ligustrums and shrubbery shall not accumulate more than 2" of growth before being trimmed.
- iv. All plants shall be maintained to a well-shaped appearance according to each species' natural growth habit unless requested otherwise by the owner's representative. Flowering shrubs shall be pruned in the proper season to allow full flowering potential for the following flower season. Grouped

plantings shall be allowed to form masses appropriate to the species.

- v. Small leafed shrubs, such as Pittosporum, Azaleas and India hawthorn, etc., are to be kept trimmed in a tight, neat appearance, with removal of partial new growth after no more than four inches of new growth appears.
- vi. Larger leafed shrubs, such as viburnum, may attain new growth reaching from 2" to 4" before removal. At no times are shrubs to display a disorderly appearance.
 - a. Ornamentals, such as crinum lilies, are to be trimmed aggressively during the rainy season to be kept neat and fungus free. This may be as frequent as every other week.
 - b. Sago palms are to be trimmed a minimum of three times a year, or more often, as directed, depending on growth and health. Azaleas are to be trimmed at regular intervals as described above with the exception of the months of October thru March when no trimming should be done to achieve maximum flowering.
 - c. Wax myrtles are to be trimmed aggressively in order to maintain a neat, compact habitat.
 - d. At no time is an herbicide to be used to rid plants of sucker growth. Instead, hand pulling or aggressive trimming routine is to be established.
 - e. All ornamentals that produce any dead fronds (i.e. coontie, sage, aztec grass, holly fern, etc.) are to be systematically checked and cleaned with special attention to early spring cleanup.
- vii. Dead plant material shall be removed by the Contractor immediately during the normal service visit and a report filed with the City detailing the location of removal and species removed.

D. Weedeater Trimming

- i. Areas inaccessible to mowing equipment shall be kept neat and trimmed as directed. Trimming of grass and weed around any fixed objects (walls, light posts, light fixtures, equipment boxes, pond structures, sign posts and trees) will be done through chemical control within a limit of six inches (6") maximum or trimmer so as not to inflict damage of any kind to structure, equipment or tree.

E. **Mulching- This should not be included in base maintenance price costs for these services are established on the proposal form for each package.**

- i. Mulching is to be performed between November 1 and December 25 each year to keep planted areas neat and fresh!

maintained. Mulch depth to be a minimum total depth of three (3) inches and placed, not dumped, as well as kept from around the immediate base of shrubs. Mulch type to be chosen by the City.

- ii. Beds should be cleared of leaves and other debris prior to adding new mulch. The intent of doing this will be to prevent unnecessary height growth of the beds.

F. Edging

- i. Edging of all walks, curbs, edging of pavements, and grass invasion shall be done weekly during the heavy growing season and bi-weekly for the remainder of the year.
- ii. All grass and dirt to be blown off onto grass areas only. No debris shall be blown onto hard surfaces or into shrub or flower beds.
- iii. Schedule for edging of soft surfaces such as turf, bed borders, and ground cover shall be performed bi-weekly or more as directed.

G. Weeding

- i. Weeding of all plant bed areas is to be as often as necessary to conform to the shrub trimming schedule, to control weed population and maintain healthy plants.
- ii. Remove weeds, vines and "voluntary" seedlings from planting beds. Weed control in landscaped areas will be accomplished by hand weeding and/or application of round-up and a pre-emergent herbicide if needed.
- iii. All weeds in sidewalks or pavement areas (including curbing) shall be chemically controlled or removed by hand.
- iv. The sod-free rings around trees are to be kept in weed-free condition, and shall be maintained at a diameter determined by the City.
- v. All mulch areas or plant beds shall be continuously maintained free of weeds or grasses.
- vi. All turf areas shall be maintained in a weed free condition. Any area that becomes infested with weeds or other undesirable grasses must be treated and or replaced at the cost of the Contractor.

H. Pruning/Tree Trimming (less than 13')

- i. All trees are to be trimmed as often as necessary to meet public safety requirements and comply with ISA and ANSI Industry Standards for tree care. Trimming of established trees shall be to a minimum of eight (8) foot and a maximum of thirteen (13) foot under canopy and pruned just outside the branch collar by the Service Provider.

- ii. Any trees greater than 13' should not be included in base maintenance price; costs for these services are established on the proposal form for each package.
 - iii. New or young trees are to be pruned with an ideal under canopy of six (6) feet or to a suitable and healthy height for each tree.
 - iv. Approved traffic (M.U.T.C.D.) warning devices shall be used when necessary to provide safety to persons and vehicular traffic within any areas undergoing pruning. Work will be scheduled after consulting with the City.
 - v. Dead palm fronds shall be removed as they occur from all palms. Seeds pods shall be removed on an as directed basis from all palms. Trimming of palm fronds shall be conducted with a hand saw. Only dead fronds shall be removed. Palms shall not be trimmed above 9 o'clock and 3 o'clock.
- I. Remove Spanish Moss
- i. Remove all low hanging Spanish Moss in ornamental trees and shrubs.
 - ii. Spanish Moss that is 8' or lower on any tree or ornamental shall be removed when other scheduled tasks are completed at the same frequency.
- J. **Annuals and/or Plant Replacements- This should not be included in base maintenance price; costs for these services are established on the proposal form for each package.**
- i. The Contractor shall be responsible for replacing any plant materials that die or become damaged to the point that the plant grade is less than Florida Number 1 as a result of neglect or damage caused by the maintenance operation.
 - ii. Replacement material shall be identical to plant species, quality and specifications of the materials at the time the loss occurs.
- K. **Insect and Disease Control This should not be included in base maintenance price; costs for these services are established on the proposal form for each package.**
- i. The Contractor shall establish, in conjunction with the City, a preventive program to insure proper care of turf and ornamentals.
 - ii. The Contractor warrants turf against infestation and disease and will replace same if deemed to be below accepted industry standards (IFAS) by the City.
 - iii. Application times for herbicide and pesticide applications shall be completed by licensed, trained individuals.
 - iv. Plants will be treated chemically as required to effectively control insect infestation and disease as environmental, horticultural and weather conditions permit. The Contractor is

responsible for any damaged areas due to disease or insect infestation.

L. Chemical Maintenance- Fertilizer and Herbicide This should not be included in base maintenance price; costs for these services are established on the proposal form for each package.

- i. Fertilization and insecticide treatments shall be provided as directed to maintain the health and appearance of all turf and plant material.
- ii. Soil amendments, fertilizer, nutrients, pesticides, fungicides, pre-emergent, post-emergent, and any other chemicals deemed proper, beneficial or required to maintain the turf and plant material by the Contractor shall be included in the chemical program monthly maintenance fee.
- iii. Monthly reports may be requested by the City. The reports should outline all treatment provided for the month and any deficits observed.
- iv. Timely and prompt treatment is to be performed on all areas detected with problems and areas at risk. A 7-10-day follow-up appointment is to be set with the City to ensure eradication of disease or pest problems. Subsequent visits, if necessary, are to be scheduled until the problems no longer exist.

M. Irrigation Inspection and Repair- This should not be included in base maintenance price; costs for these services are established on the proposal form for each package.

- i. Complete irrigation inspections shall be performed one (1) time per month at minimum.
- ii. Details of the inspection shall be recorded on a log sheet (to be submitted with the monthly billing) and consist of the following:
 - a. Turning on each zone and inspecting each head for the proper coverage, including straightening, adjusting the output of water, adjusting spray pattern and unclogging any heads.
 - b. Repairing broken heads and lateral lines, as necessary.
 - c. Checking the irrigation controller(s) for proper operation and programming. If there are battery controllers on the site, check each for battery life and replace at 75% depletion.
 - d. Checking all zone valves for proper open and closure, making sure to inspect for leaking from the mainline.
 - e. Checking water source for leaking and visual inspection of backflow device, if present.
 - f. Visually inspect turf, planters and trees in irrigated areas for signs of drought stress and effect adjustments and/or repairs to remedy the issue.

- iii. The Contractor shall submit a detailed report, at the time of billing of each monthly service, consisting of the clock and location, each zone by number, and any repairs or work performed during that service. All parts used will be itemized on the bill with a maximum of \$ 50.00 billed for repairs without VERBAL approval during the regular monthly scheduled maintenance visit.
 - a. If there is an additional cost for repairs beyond the maximum of \$50.00, the City must be given a verbal report of the repair and costs involved before the work is to be performed. No payment will be made for heads or parts damaged by the Contractor.
- iv. Contractor is to immediately prepare an estimate to repair or replace damaged parts on the property within the areas specified in this agreement to meet original specifications with commercial quality irrigation parts. All work performed by Contractor to meet industry standards. All damaged irrigation heads shall be turned in each month along with the monthly billing in order to qualify for payment.
- v. Labor cost for these services is established on the proposal form for each project. Material costs shall be paid on the basis of approved wholesale documented cost plus 15% for overhead and profit.
- vi. Contractor is to immediately notify the City if a mainline leak is noticed. Should the Contractor need to shut down the mainline for any reason, the City must be contacted at: (407) 327-5962.

N. Other Scope as specifically directed by City- This should not be included in base maintenance price; costs for these services are established on the proposal form for each package.

- i. Service Provider is to prepare proposal for additional work as it is requested by the City prior to commencing with additional work. Prior written approval is required for all additional scope not listed on this document.

2) Contractual Information

- A. The work to be performed under this Contract consists of landscape maintenance services for the City of Winter Springs Municipal Facilities. Perform all work in accordance with the Contract Documents. Furnish all materials, equipment, tools, and labor which are reasonably and properly inferable and necessary for the proper completion of the work, whether specifically indicated in the Contract Documents or not. Cost for all services listed shall be considered part of the monthly maintenance and shall be included in the cost for monthly maintenance at each site.

SECTION 00700 – DRUG FREE WORKPLACE FORM

The undersigned proposer, in accordance with Florida Statute 287.087 hereby certifies that Yellowstone Landscape does:

(Name of Business)

1. Publish a statement notifying employees that the unlawful manufacture, distribution, dispensing, possession or use of a controlled substance is prohibited in the workplace and specifying the actions that will be taken against employees for violations of such prohibition.
2. Inform employees about the dangers of drug abuse in the workplace, the business's policy of maintaining a drug-free workplace, any available drug counseling, rehabilitation, and employee assistance programs, and the penalties that may be imposed upon employees for drug abuse violations.
3. Give each employee engaged in providing the commodities or contractual services that are under contract a copy of the Drug-Free statement.
4. Notify the employees that as a condition of working on the commodities or contractual services that are under contract, employee will abide by the terms of the statement and will notify the employer of any conviction of, or plea of guilty or nolo contendere to, any violation of Chapter 893 or of any controlled substance law of the United States or any state, for a violation occurring in the workplace no later than five (5) days after such conviction.
5. Impose a sanction on, or require the satisfactory participation in a drug abuse assistance or rehabilitation program if such is available in the employee's community, by any employee who is so convicted.
6. Make a good faith effort to continue to maintain a drug-free workplace through implementation of this section.

As the person authorized to sign the statement, I certify that this business complies fully with the above requirements.



(Authorized signature)

10/21/19

(Date)

Landon Pyle

(Print/type name as signed above)

****THIS FORM MUST BE COMPLETED AND RETURNED WITH YOUR SUBMITTAL.**

NON-COLLUSION AFFIDAVIT OF PRIME RESPONDENT

STATE OF _____)

COUNTY OF _____)

_____, being duly sworn, deposes and says that:

(1) He/she is _____ of _____,
Title Firm/Company

the respondent that has submitted the attached response.

(2) He/she is fully informed respecting the preparation and contents of the attached solicitation and of all pertinent circumstances respecting such solicitation.

(3) Such solicitation is genuine and is not a collusive or sham solicitation.

(4) Neither the said respondent nor any of its officers, partners, owners, agent representatives, employees or parties in interest including this affiant, has in any way, colluded, conspired, or agreed, directly or indirectly, with any other respondent, firm or person, to submit a collusive or sham response in connection with the Agreement for which the attached response has been submitted or to refrain from proposing in connection with such Agreement, or has in any manner, directly or indirectly, sought by Agreement or collusion or communication or conference with any other responder, firm or person to fix the price or prices in the attached solicitation or of any other respondent, or to fix any overhead, profit or cost element of the proposed price or the proposed price of any other responder, or to secure through any collusion, conspiracy, connivance or unlawful Agreement any advantage against the City of Winter Springs, Florida, or any person interested in the proposed Agreement.

(5) The price or prices quoted in the attached response are fair and proper and are not tainted by any collusion, conspiracy, or unlawful Agreement on the part of the proposer or any of its agents, representatives, owners, employees, or parties of interest, including affiant.

(Signed)

(Title)

STATE OF FLORIDA

COUNTY OF SEMINOLE

The foregoing instrument was acknowledged before me this _____ by _____, who is personally known to me or who has produced _____ as identification and who did (did not) take an oath.

(Signature of Notary Public)

(Name of Notary Typed, Printed or Stamped)

Notary Public

(Commission Number)

****THIS FORM MUST BE COMPLETED AND RETURNED WITH YOUR SUBMITTAL.**

SECTION 00900 – INSURANCE REQUIREMENTS FORM

Insurance Type	Required Limits
<input checked="" type="checkbox"/> Worker's Compensation	Statutory Limits of Florida Statutes, Chapter 440 and all Federal Government Statutory Limits
<input checked="" type="checkbox"/> Employer's Liability	\$1,000,000 each accident, single limit per occurrence
<input checked="" type="checkbox"/> Commercial General Liability (Occurrence Form) patterned after the current ISO form	\$1,000,000 single limit per occurrence \$3,000,000 aggregate for Bodily Injury Liability & Property Damage Liability. This shall include Premises and Operations; Independent Contractors; Products & Completed Operations & Contractual Liability.
<input checked="" type="checkbox"/> Indemnification	To the maximum extent permitted by Florida law, the Contractor/Vendor/Consultant shall indemnify and hold harmless City of Winter Springs, its officers and employees from any and all liabilities, damages, losses and costs, including, but not limited to, reasonable attorneys' fees and paralegals' fees, to the extent caused by the negligence, recklessness, or intentional wrongful conduct of the Contractor/Vendor/Consultant or anyone employed or utilized by the Contractor/Vendor/Consultant in the performance of the Agreement. This indemnification obligation shall not be construed to negate, abridge or reduce any other rights or remedies which otherwise may be available to an indemnified party or person described in this paragraph. This section does not pertain to any incident arising from the sole negligence of the City of Winter Springs.
<input checked="" type="checkbox"/> Automobile Liability	\$1,000,000 each person; Bodily Injury & Property Damage, Owned/Non-owned/Hired; Automobile Included.
<input type="checkbox"/> Other	

Vendor shall ensure that all subcontractors comply with the same insurance requirements that he/she is required to meet. The same Vendor shall provide the City with certificates of insurance meeting the required insurance provisions.

The City of Winter Springs must be named as **"ADDITIONAL INSURED"** on the Insurance Certificate for Commercial General Liability where required.

The Certificate Holder shall be named as City of Winter Springs.

Thirty (30) days cancellation notice required.

The undersigned firm agrees to obtain, prior to award, if selected, insurance as stated above.

Yellowstone Landscape, Landon Pyle

PROPOSER/BIDDER

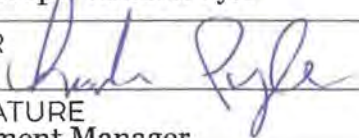

AUTHORIZED SIGNATURE

Business Development Manager

OFFICER TITLE

10/22/19

DATE

****THIS FORM MUST BE COMPLETED AND RETURNED WITH YOUR SUBMITTAL.**



YELLOWSTONE
LANDSCAPES

About Us

ABOUT US



YELLOWSTONE
LANDSCAPE



Yellowstone Landscape began in 2008 with the unification of established, independently successful regional landscape companies. For more than a decade since, we've been linked by a common goal to better serve our clients, sharing our experience in landscape maintenance, landscape installation, landscape enhancement, and tree care services.

Yellowstone Landscape has become one of the industry's fastest growing and most trusted commercial landscaping companies, proudly serving more than 3000 clients from local operating facilities across the South and Southwest.

Yellowstone Landscape is dedicated to creating and maintaining green spaces that enhance the quality of life where you live, work, and play. We provide professional landscaping services to some of the most outstanding homeowner associations, local governments, master planned developments, resorts, corporate campuses, commercial office parks, schools, hospitals, apartment communities and retail centers in the South and Southwest United States.

Quick Facts About Yellowstone Landscape:

- More than 30 Local Operating Branches Across the South and Southwestern United States
- Over 2500 Full-Time Employees & 800 Seasonal and Part-Time Associates
- More than 1000 Vehicles in Our Service Fleet
- Established Executive Leadership and Local Operations Management Teams
- Safety Program Recognized as Among the Most Proactive in the Landscape Industry
- 93% Client Satisfaction Rating in our most recent annual client survey
- 29 National Landscape Awards of Excellence received since 2008
- Ranked #5 in the 2019 Top 100 Largest Lawn & Landscape Companies in North America
- More than 1,000,000 trees planted along public roadways in the last decade



Statement of Corporate Stability

Yellowstone Landscape understands your need to ensure that any potential landscape partner operates in a manner that supports long-term stability, and to verify our ability to provide services to your property in the future.

Our firm was established nearly a decade ago, by combining already successful, regional landscape companies that had existed for more than twenty years, before they joined together to form Yellowstone Landscape. Since 2008, we've been linked by a common goal to better serve our clients, sharing decades of experience in landscape design and installation, tree care services and landscape maintenance. As one of the landscape industry's fastest growing and most respected commercial landscaping companies, we proudly serve more than 3000 clients from 30 local branch operations facilities across 8 states in the South and Southwest. This makes us one of the largest commercial landscaping companies in the United States.

We are incorporated in the state of Delaware, chartered in January of 2008. As a privately held company, it is not our practice to disclose financial statements, however, we can confirm that our firm's annual revenue exceeded \$230,000,000 in 2018. We also attest that we operate our company in accordance with all generally accepted best accounting practices, as have been confirmed by independently conducted audits each year since our founding. As a part of the investment portfolio of CIVC Partners, a private equity firm based in Chicago, Illinois, Yellowstone is fully prepared to fund any capital expenses necessary to ensure our ability to perform services at full capacity in advance of the stated contract start date, should we be selected as your landscape contractor.

Landscape Maintenance



YELLOWSTONE
LANDSCAPE



Landscape Maintenance is all about the details. We're committed to getting the details right, so you can enjoy your landscape and take pride in its appearance.

From week to week, month to month, and year to year, there are hundreds of details that need to be coordinated for your landscape to look its best. Assuring that none of those details are overlooked requires a professionally administered, integrated Landscape Maintenance program.

Synchronizing routine maintenance activities like mowing, edging, weeding, trimming and clean-up, with fertilization and pest management applications, and your irrigation system's schedule and maintenance is no easy task.

That's why we incorporate all the details of our landscape services into your Plan for Success™.

Our Landscape Maintenance teams are trained in our industry's Best Practices. They behave as if they were a part of your staff and work hard to solve problems while they're still called **opportunities**. If the unexpected happens, our teams respond to correct the problem, quickly and professionally.

Your dedicated Account Manager will provide regular updates about what we're doing to maintain your landscape. Our goal is to provide you with **all the information** you need about your landscape, when you need it.

Irrigation Installation & Management



There is nothing more essential to the success of your landscape than regular access to the right amount of water.

Commercial irrigation systems are sophisticated technology that require special certification to install and operate.

Our Irrigation Installation and Management Professionals are experts in all major commercial irrigation systems. From older systems in need of frequent repairs and updates, to the most modern and innovative water-wise systems available, our Irrigation Teams are dedicated to protecting your valuable water resources. Once installed, we always adhere

to local ordinances governing water use and have implemented the principles of the leading industry groups. These guidelines govern how we design, install, and maintain your irrigation system.

Professional irrigation management is an essential service to eliminate waste in your water consumption and reduce your water usage.

Yellowstone Landscape provides you with the most experienced team of Irrigation Professionals in the industry.

Tree Care Services



YELLOWSTONE
LANDSCAPE



Your trees add beauty and value to your property. In the case of mature trees, they are an absolutely irreplaceable asset. Keep them healthy and protect your property with regular evaluations and treatments.

Yellowstone Landscape is a full service tree care company, specializing in Plant Health Care and Pruning in accordance with the highest industry standards. Our Tree Care teams are led by certified Arborists, educated and trained in all aspects of Arboriculture. We're dedicated to

improving and protecting your trees and shrubs, utilizing the latest innovations in tree care science.

Our Tree Care services include:

- Pruning
- Cabling & Bracing
- Lightning Protection
- Fertilization
- Disease & Pest Management
- Tree Removal
- Tree Planting
- Stump Grinding
- Root Management

Landscape Design

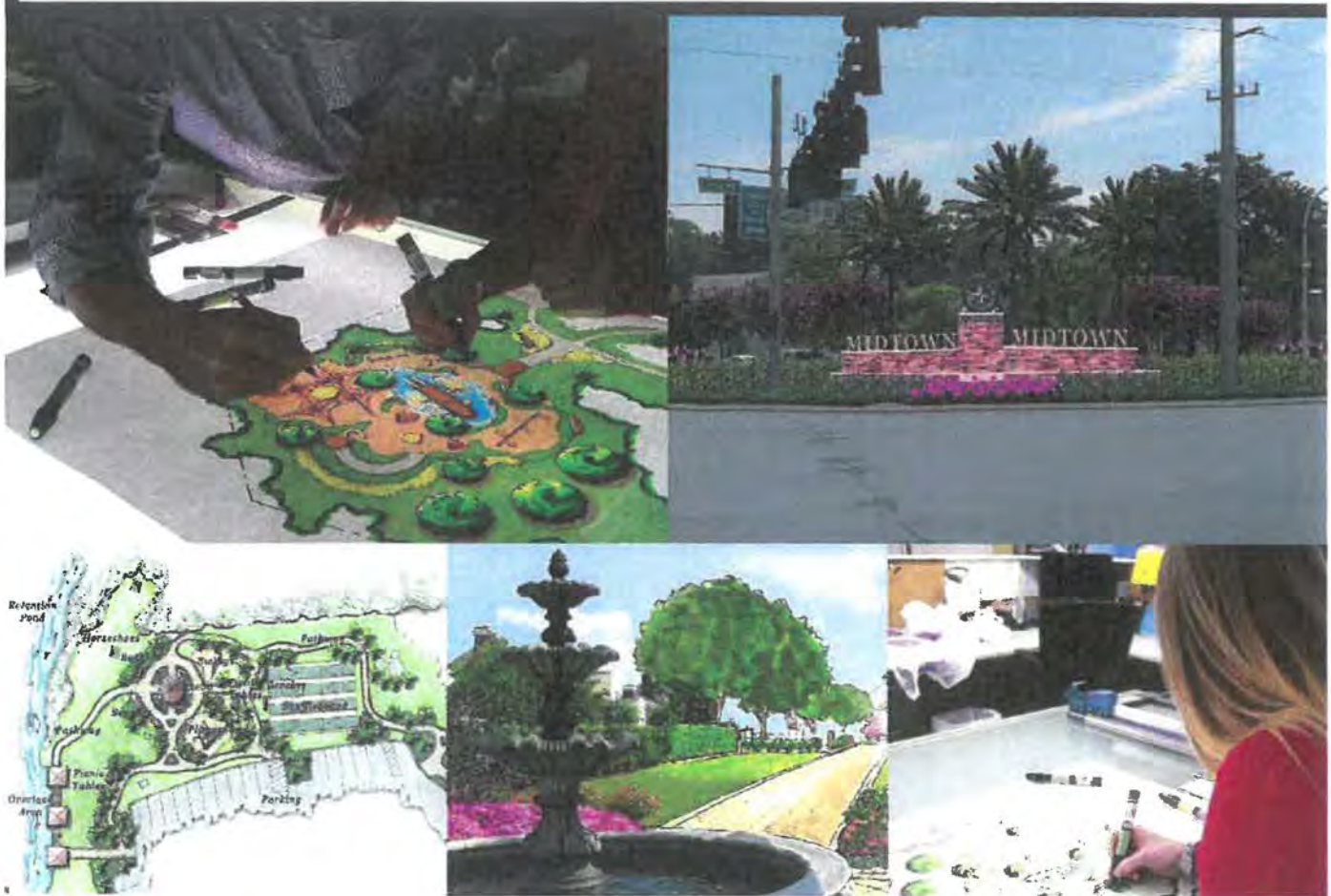

You need your landscape to look its best, but you're not quite sure where to get started.

Whether you need a landscape design plan for a new development or just want to enhance a few feature areas in your existing landscape, our Landscape Designers are ready to help you see your landscape's full potential.

Our Designers are specially trained, creative professionals. They're knowledgeable about all the latest concepts in landscape design and they're also familiar with your area's local plant materials. This ensures that what they select to plant will thrive once it's in the ground. The

last thing you want is to invest in a landscape installation project, only to see the plants fail within the first year.

Working with a Landscape Designer starts with a meeting to find out what your goals are for your project. They'll create photo renderings so you can actually see what your new landscape will look like, before it's planted. You'll be a part of the process from beginning to end.

And best of all, we offer Landscape Design as a complimentary service to current Landscape Maintenance clients when we install your landscape enhancement.

Landscape Installation



YELLOWSTONE
LANDSCAPE



You need your landscape installation project completed safely, on time and on budget.

Our Landscape Installation Teams will do everything we can to make sure your project stays on schedule (or gets back on schedule), with experience and capabilities scalable to handle any project and any timeline.

All Landscape Installation projects start with a meeting to thoroughly review your site and your design plans, verifying that the plant material selected is suitable for your project's environment. With experts on staff in Landscape Design and Landscape Maintenance, we'll offer recommendations to preserve the

long term health and appearance of the project after installation. We can also suggest alternate, native plant materials and trees to help conserve water usage, while preserving the project's intended visual appeal.

We offer extended warranties on all plant materials that we install, when you allow us to provide ongoing landscape maintenance services. We offer this to our clients because we install every landscape with the goal to become your lifetime landscape service partner, growing with you as your landscape matures.

Client Surveys



Each year our clients are asked to complete a brief on line survey to tell us how we are performing in our mission to create premier properties and build lasting relationships.

The survey asks that each client rank us in the following categories:

- Quality of Work
- Ability to Meet Expectations
- Responsiveness to Individual Needs
- Clarity of Information
- Level of Respect for You
- Overall Satisfaction

It concludes with the simple question, "Would you recommend Yellowstone Landscape?"

Results from our most recent client survey:

Category	Positive Responses
Quality of Work	95%
Ability to Meet Expectations	93%
Responsiveness to Individual Needs	95%
Clarity of Information	95%
Level of Respect for You	100%
Overall Satisfaction	94%
Would Recommend Yellowstone Landscape	94%

Committed to Safety



YELLOWSTONE
LANDSCAPE



Yellowstone Landscape has made safety our number one priority. We know that we are equally responsible for the safety of our employees, and our clients' residents, employees, guests and their property.

Our commitment to safety includes providing a safe, healthy work environment, kept free from hazards. Whether starting or ending the day at one of our branch locations, traveling over the area's roadways, or at a client's work site, all Yellowstone Landscape employees are trained to behave professionally and remain alert to all potential safety hazards they may encounter.

Our Commitment to Safety includes:

- New Employee Training on Safe Operating Procedures
- Strict Compliance to All OSHA Regulations
- Weekly Tailgate Talks Conducted with All Field Service Teams
- Annual Safety Rodeos with Industry Safety Experts
- Dedicated Safety Officers in Each Branch Location
- Mandatory Use of Appropriate Personal Protective Equipment (PPE) at All Times

Environmental Stewardship



As a leader in the landscaping industry we have an added responsibility to be good stewards of our natural resources. We also understand that many clients have become keenly aware of the need to reduce their environmental impact.

Our initiatives toward responsible environmental stewardship include:

Integrated Pest Management: IPM Programs use a combination management tools to create an environment where it is less likely that the pest will return.

Innovation Irrigation: This includes smart controllers, rain sensors, micro irrigation

and drip irrigation to eliminate water waste, integrating recycled water intakes where natural sources are available.

Reducing Carbon Emissions: EFI equipment used by our service personnel reduces our fuel consumption by 25% compared with traditional outdoor power equipment.

Organic Options: We offer organic alternatives to all traditional management solutions.

Drought-Tolerant Plants & Trees: Installing the right plant material for your property's environment reduces the water consumption necessary for your plants and trees to thrive.

Services for Public Sector Clients



We are proud to serve Public Sector clients across the South, and to be a part of some tremendously successful projects beautifying our local communities. **We understand the challenges that local governments and agencies face in managing their public green spaces.**

Public parks, trails, and streetscapes create unique opportunities to enrich the lives of your community's residents. Investing in professional landscape services delivers a consistently high-quality appearance, and does so at a lower cost than in-house grounds maintenance services.

Our professional landscaping services offered to Public Sector clients include award-winning

Landscape Design and Installation teams, ready to deliver beautiful landscape enhancements and installations. When we continue to maintain the project for you, we can even extend our normal warranty on installed plant materials.

We'll also work with you to identify any possible liabilities or hazards in your community's public spaces. With services like raising tree canopies and making sure drains are kept clear of debris, our Landscape Professionals partner with you to keep your residents safe from hazards. And, in case of a natural disaster or extreme weather event, our crews will be there to assist with clean up after the storms have passed.

FEATURED PROJECT

The City of Ormond Beach



LOCATION

Ormond Beach, Florida

CLIENT

The City of Ormond Beach

PROPERTY TYPE

Local Government

SERVICES PROVIDED

Landscape Design
Landscape Enhancement
Landscape Maintenance

The City of Ormond Beach, an upscale community located just north of Daytona Beach, Florida, is home to approximately 40,000 residents, nicknamed “The Birthplace of Speed”.

In 2012, multiple landscape service contracts were consolidated into one partner agreement with Yellowstone Landscape, resulting in a more uniform appearance across the city’s facilities, parks, and rights of way. High profile areas, most frequented by the city’s residents, are detailed each week to maintain their desired

appearance during the community’s active events schedule.

The grounds services agreement also includes irrigation system maintenance and repairs, trash and debris removal at parks and city facilities, maintenance of more than 50 manicured medians, and athletic field maintenance of the City’s sports field complexes.

In 2016, The City’s landscape was recognized by FNGLA, Florida’s state landscaping association, with an Award of Excellence.

FEATURED PROJECT

The City of New Smyrna Beach



YELLOWSTONE
LANDSCAPE



LOCATION

New Smyrna Beach, Florida

CLIENT

The City of New Smyrna Beach

PROPERTY TYPE

Local Government

SERVICES PROVIDED

Landscape Maintenance

When *The City of New Smyrna Beach* launched an initiative to promote more tourism to the City, it also requested solicitations from the area's professional landscape firms to improve and maintain the appearance of City rights of way, including major state and county highways.

Yellowstone Landscape was selected to supply these services to the City in 2015 with an initial contract for a 3 year term.

Included in the contract, The City of New Smyrna Beach identified a total of

8 separate areas, including a 2.2 mil paved multi-use trail, and specified unique maintenance standards for each area, placing special emphasis on the City's gateway areas located just off of the I-95 exit ramps and a major intersection leading to the City business district.

Since the initial award, Yellowstone Landscape's quality of work has led the City to award additional areas, including the City's highly visible downtown corridor and retail district.

FEATURED PROJECT

Reunion Resort & Club



LOCATION
Orlando, Florida

CLIENT
Salamander Hotels & Resorts, GMS,
Aegis Community Management

PROPERTY TYPE
Resort Community

SERVICES PROVIDED
Landscape Design
Landscape Installation
Landscape Maintenance

Reunion Resort & Club is a 2,300-acre master-planned resort community located in Orlando, Florida.

Reunion is proud to be the only resort community in the world that offers three signature golf courses, designed by golf legends: Jack Nicklaus, Arnold Palmer and Tom Watson.

Reunion's Linear Park, a popular wedding venue, includes structured planting beds and majestic oaks. The five-acre water park, another popular area of the resort, brims with colorful, tropical plants.

Since design and installation began, Yellowstone Landscape has been Reunion's exclusive landscape service partner.

The resort community's landscape maintenance areas include over 800,000 square feet of ornamental beds in addition to the acres of manicured turf, 3,000 trees and over 500 palms.

The resort's active special event schedule requires constant coordination between service teams and Reunion's property management.

FEATURED PROJECT

Legacy of Leesburg



YELLOWSTONE
LANDSCAPE



LOCATION

Orlando, Florida

CLIENT

Leland Management

PROPERTY TYPE

55+ Community Association

SERVICES PROVIDED

Landscape Design
Landscape Enhancement
Landscape Maintenance

Legacy of Leesburg is an active retirement lifestyle community, located 45 minutes from Orlando. The developer's intent is to provide all the modern amenities active adults expect in a home, placed in a setting that encourages them to explore central Florida's natural beauty.

The result is that nearly all of Legacy's 1000 homes have a view of either a natural conservation area, or one of the nineteen ponds that dot the community's landscape. With over seven miles of maintained walking

paths along thirteen trails, residents are frequently seen strolling in the shade of the hundreds of ancient oaks

Legacy is also home for many types of wildlife. Alligators, bobcats, cranes and other native birds are commonly seen across the community.

The 450 palms are pruned once per year and the annual flower beds, while small in size, do add vibrant pops of color to Legacy's entrances and clubhouse.

FEATURED PROJECT

Walt Disney World Swan & Dolphin Resort



YELLOWSTONE
LANDSCAPE

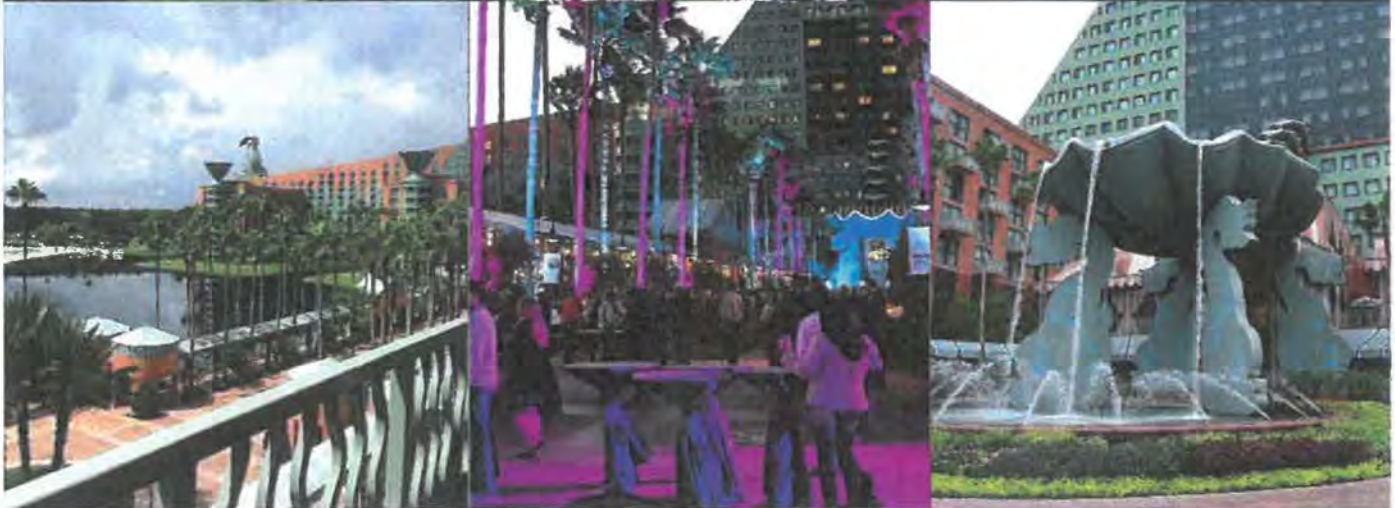

LOCATION
Orlando, Florida

CLIENT
Starwood Hotels and Resorts

PROPERTY TYPE
Resort Community

SERVICES PROVIDED
Landscape Design
Landscape Enhancement
Landscape Maintenance

The Swan and Dolphin Resort is situated on 87 acres of beautiful lakefront property within Orlando's most famous attraction, Walt Disney World. The award winning resort is comprised of two separate hotels, The Swan and The Dolphin, joined by a palm tree-lined bridge between the two hotels.

The massive resort features all the expected Disney amenities, including 5 pools, a white sand beach, restaurants, spas, and conference spaces,

surrounded by immaculately maintained tropical landscaping.

Frequent events like the annual Food and Wine Festival, can make maintenance of the property's grounds a challenge at times.

As a designated Florida Green Lodging Property, the resort mandates the use of integrated pest management practices and that service teams monitor emissions and irrigation usage in order to minimize the environmental impact of our services.

FEATURED PROJECT

Waldorf Astoria Orlando Resort



YELLOWSTONE
LANDSCAPE



LOCATION
Orlando, Florida

CLIENT
Waldorf Astoria

PROPERTY TYPE
Resort

SERVICES PROVIDED
Landscape Design
Landscape Enhancement
Landscape Maintenance

The Waldorf Astoria Orlando Resort features unrivaled luxury accommodations from one of the world's most famous hotel brands.

The client requires meticulous attention to detail and an immaculate appearance in their landscape at all times. Yellowstone Landscape delivers best in class landscape management with attention to detail, pro-active services and sensitivity to the Waldorf guests' experience.

Landscape service crews use electric equipment to reduce noise on the property, and only service the landscape during weekday mornings, completing by 8am to preserve the Waldorf Astoria's focus on their guest's comfort.

The property was awarded a National Landscape Award of Excellence Grand Award in 2012, recognizing it as one of the nation's most outstanding commercial landscape management projects.

FEATURED PROJECT

Embry-Riddle Aeronautical University



LOCATION

Daytona Beach, Florida

CLIENT

Embry-Riddle
Aeronautical University

PROPERTY TYPE

University Campus

SERVICES PROVIDED

Landscape Design
Landscape Installation

Embry-Riddle Aeronautical University is the world's largest, fully accredited university specializing in aviation and aerospace. The university's 185-acre Daytona Beach campus serves more than 5200 students. The expanding university's leadership, focused on creating an exceptional student experience from the curb to the classroom, partnered with Yellowstone Landscape to bring a cohesive and consistent visual appeal to the campus, reflective of the campus' increasingly diverse student population.

With the *Jim W. Henderson Welcome and Administration Center*, Yellowstone design and construction specialists collaborated with the Embry-Riddle team to select and install landscape materials appropriate for the project, including tropical palms, colorful ground coverings and annuals, manicured Zoysia turf, and over 13 tons of polished beach pebbles to complement the building's stunning fountains and aeronautically inspired architecture.

FEATURED PROJECT

Home Depot Store Support Center



YELLOWSTONE
LANDSCAPE



LOCATION
Atlanta, Georgia

CLIENT
Home Depot

PROPERTY TYPE
Corporate Campus

SERVICES PROVIDED
Landscape Design
Landscape Enhancement
Landscape Maintenance

Home Depot's Store Support Center serves as the company's global headquarters - housing corporate IT Support, Human Resources, Marketing, Finance, and the offices of the company's Executives.

The 43-acre campus includes over 1.7 million square feet of office space occupied by 5,000 Home Depot employees each business day.

The campus features a 22 classroom learning and child care center, Little Apron Academy. Yellowstone Landscape completed a renovation

project of the center's artificial turf playgrounds in the spring of 2014, the first of several landscape enhancements performed since Yellowstone was selected as the campus' landscape service provider.

Home Depot has since commissioned an ongoing campus improvement plan. It includes landscape design and installation projects to be completed over the next several years, aimed to provide employees with more amenity and recreation areas.

References



At Yellowstone Landscape, we pride ourselves on building lasting relationships with our clients. These clients have entrusted us as their landscape maintenance partner and would be happy to speak with you about our firm and the services that we provide for them.

Project Name: City of Port Orange (contract over \$500K/year)
Client Since: 2015
Services Provided: Landscape Design & Installation, Landscape Maintenance
Client Contact Information: Branford Adumuah, *Maintenance Operations*
386.506.5575

Project Name: City of New Smyrna Beach (contract over \$450K/year)
Client Since: 2015
Services Provided: Landscape Design & Installation, Landscape Maintenance
Client Contact Information: Faith G. Miller, *Maintenance Operations Director*
386.424.2202

Project Name: The City of Ormond Beach (contract over \$200K/year)
Client Since: 2012
Services Provided: Landscape Design & Maintenance, Landscape Enhancements, and Athletic Field Maintenance of the City's Sports Complexes
Client Contact Information: Mike Demchak, *Contract Manager*
386.676.3286
michael.demchak@ormondbeach.org

Project Name: Reunion Resort and Club (876 homes, resort, and common areas)
Client Since: 2005
Services Provided: Landscape Design & Installation, Landscape Maintenance
Client Contact Information: David Burman, *AMS, PCAM, Founder & President*
Aegis Community Management Solutions
8390 Champions Gate, Florida 33896
863.256.5052
davidb@aegiscms.com

Brian Wester

PROFESSIONAL EXPERIENCE SUMMARY

As the **Regional Vice President** of Yellowstone Landscape, Brian Wester is responsible for overseeing all of the region's daily operations. Having played a key role in establishing the Central Florida district of the company, he previously managed the district from 2004 until 2010, when he assumed his present role leading the Southern region.

EDUCATION

1999 - 2002 **Lake City Community College** **Lake City, FL**
AS, Golf Course Operations

RELEVANT PROFESSIONAL EXPERIENCE

Jan 2011-present **Yellowstone Landscape** **Jacksonville, FL**
Regional Vice President

- Responsible for all landscape operations within the Yellowstone Landscape, Southern region, including Florida, Georgia, and South Carolina.
- Oversees all branch operations and employees.
- Builds operational strategies that improve company-wide quality.
- Manages operations training and leads continuous improvement efforts.

June 2003-Dec 2010 **Austin Outdoor, LLC** **Orlando, FL**
District Manager

- Responsible for landscape construction and maintenance operations.
- Works with all plans, blueprints and specifications for each project.
- Hires and coordinates construction crews.
- Balances the workload and staging materials for each project.
- Maintains up-to-date roster of all personnel and job activities.
- Identifies equipment and resources needed for each project.
- Assures that preventive maintenance is performed on all equipment.
- Conducts regular inspections of in-progress projects.
- Identifies training needed for personnel.

2002 - 2003 **Hammock Dunes Golf Club** **Palm Coast, FL**
Assistant Superintendent

- Managed 16-man crew.
- Communicated and worked with project managers on construction projects.
- Supervised applications of fertilizers and chemicals.
- Set up daily computerized irrigation schedules.

Josh Cochran

PROFESSIONAL EXPERIENCE SUMMARY

As the **Branch Manager** of Yellowstone Landscape, Josh Cochran is responsible for overseeing all of the branch's daily operations along with managing budgets and staffing needs with the help of feedback from the branch's Account Managers as well.

EDUCATION

2004 - 2005 **Seminole State College** **Sanford, FL**
Associate of Science – Drafting and Design – CAD Specialization

RELEVANT PROFESSIONAL EXPERIENCE

Jan 2019-present **Yellowstone Landscape** **Orlando, FL**
Branch Manager

- Oversees all branch operations and staffing.
- Builds operational strategies that improve performance on properties.
- Manages operations team as well as office staff and business development staff.
- Oversees all Safety policies and procedures in the branch.

2017 – 2018 **Yellowstone Landscape** **Orlando, FL**
Operations Manager

- Responsible for landscape maintenance and installation operations.
- In charge of scheduling for all crews for entire branch.
- Interviewed and hired all employees during this time.
- Worked with mechanic to ensure all equipment remained in a serviceable and working manner.
- Identifies training needed for personnel.
- Worked with Safety team to ensure all safety guidelines and standards were being followed.

2015 – 2017 **Yellowstone Landscape** **Orlando, FL**
Sr. Account Manager

- Worked with Account Managers to ensure all crews had what they needed to perform their jobs at the standard that was expected.
- Helped Operations Manager with scheduling for the maintenance crews and also the scheduling of all landscape installs.
- Managed several high end properties that required the highest quality and communications on a daily basis.

Josh Cochran *Page 2*

2009 – 2014

TruGreen

Orlando, FL

Route Manager

- Applied fertilization, herbicide, insecticide, and fungicide on all properties in accordance with the State of Florida Department of Agriculture and Florida Best Management Practices standards.
- Doubled the size of route in one year by producing quality results and being able to sell off of that.
- Gained extensive knowledge of how plants and turf grasses grow and what they need in order to thrive in the Central Florida climate.

2005 – 2009

Kelli Green Landscape

Casselberry, FL

Operations Manager

- Oversaw all payroll and employee issues
- Created routes for multiple landscape maintenance crews that saved the company money by being more efficient
- Worked directly with owner and gained knowledge on company finances and how to better understand how a business is run.

David Boldman

PROFESSIONAL EXPERIENCE SUMMARY

As an **Account Manager** of Yellowstone Landscape, David Boldman is responsible for coordinating, implementing and maintain landscape management and installation projects, communicating to the client to keep them updated on the property and projects.

As the **Fert/Chem Manager** for Yellowstone landscape, David Boldman is responsible for scheduling applications according to the contract's specifications, using the latest technologies and materials to ensure insects, diseases, and the health of the plant or turf material is at its highest quality.

EDUCATION

2001-2004 Valencia community college Orlando FL
General studies

RELEVANT PROFESSIONAL EXPERIENCE

Sept 2015 - present Yellowstone Landscape Orlando, FL
Account manager

- Responsible for running the daily maintenance of each account.
- Establishing a trusting relationship with the client
- Ensure peak performance and delivery of high-quality projects.
- Identifies opportunities to enhance client's property.
- Manages training and leads continuous improvement efforts.

Jan 2011 – Aug 2015 Trugreen chendlawn Orlando, FL
Route Manager

- Responsible for checking and maintaining the plants and turf of Trugreen clients.
- Trained in horticulture and agronomics specifically for commercial properties.
- Gained extensive knowledge of plants and turf grasses grow and what they need in order to thrive in Central Florida.

Aug 2009 – Dec - 2010 B & M landscaping Orlando FL
Manager

- Managed maintenance routes
- Managed demolition and install projects.
- Applied fertilizer and chemical to control the health of properties.

ADDITIONAL QUALIFICATIONS

Certified Pest Control Operator – 4 years

OSHA Level II Hazardous Materials Operations

Jack Simmons

PROFESSIONAL EXPERIENCE SUMMARY

As a **Landscape Designer** at Yellowstone Landscape, Jack Simmons utilizes his skills in landscape design, his advanced rendering skills and breadth of horticultural knowledge. Since joining the team, he has contributed to the firm's ability to produce high-quality designs and presentations.

EDUCATION

2009-2013 **University of Kentucky** **Lexington, KY**
BS, Landscape Architecture

PROFESSIONAL EXPERIENCE

2013–Present **Yellowstone Landscape** **Orlando, FL**
Landscape Designer

- Designs landscape enhancements to increase aesthetic appearance.
- Creates conceptual designs for clients.
- Creates design renderings for new home construction and installations.
- Creates all designs within budgetary guidelines.
- Conducts presentations of the designs.
- Creates site plans and service area maps for client presentations.

2012-2013 **Alltech** **Nicholasville, KY**
Design Team Landscape Architecture Intern

- Develop Planting Plans for California and Florida properties.
- Design Renderings for Residential properties.
- Design Renderings for Golf Courses and Clubhouses.

2012-2013 **John Carloftis Fine Gardens** **Lexington, KY**
Draftsman and Project Board Designer

- Create Plans using Drafting Software (Autocad)
- Present Planting Designs to Clients
- Oversee Planting Installations

RECOGNITIONS

- University of Kentucky Dean's List Student, 2010-2012
- International Dean's List, 2012



YELLOWSTONE
LANDSCAPE

Licenses and Certifications

Request for Taxpayer Identification Number and Certification

Give Form 1
requester. I
send to the

▶ Go to www.irs.gov/FormW9 for instructions and the latest information.

Print or type. See Specific Instructions on page 3.	1 Name (as shown on your income tax return). Name is required on this line; do not leave this line blank. Yellowstone Landscape - Southeast, LLC		
	2 Business name/disregarded entity name, if different from above dba Yellowstone Landscape		
	3 Check appropriate box for federal tax classification of the person whose name is entered on line 1. Check only one of the following seven boxes.		4 Exemptions (codes apply to certain entities, not individual instructions on page 3): Exempt payee code (if any) _____ Exemption from FATCA report code (if any) _____ <small>(Applies to accounts maintained outside the</small>
	<input type="checkbox"/> Individual/sole proprietor or single-member LLC <input type="checkbox"/> C Corporation <input type="checkbox"/> S Corporation <input type="checkbox"/> Partnership <input type="checkbox"/> Trust/estate		
	<input checked="" type="checkbox"/> Limited liability company. Enter the tax classification (C=C corporation, S=S corporation, P=Partnership) ▶ C Note: Check the appropriate box in the line above for the tax classification of the single-member owner. Do not check LLC if the LLC is classified as a single-member LLC that is disregarded from the owner unless the owner of the LLC is another LLC that is not disregarded from the owner for U.S. federal tax purposes. Otherwise, a single-member LLC that is disregarded from the owner should check the appropriate box for the tax classification of its owner.		
	<input type="checkbox"/> Other (see instructions) ▶		
	5 Address (number, street, and apt. or suite no.) See instructions. 3235 N. State Street, PO Box 849		Requester's name and address (optional)
6 City, state, and ZIP code Bunnell, FL 32110			
7 List account number(s) here (optional)			

Part I Taxpayer Identification Number (TIN)

Enter your TIN in the appropriate box. The TIN provided must match the name given on line 1 to avoid backup withholding. For individuals, this is generally your social security number (SSN). However, for a resident alien, sole proprietor, or disregarded entity, see the instructions for Part I, later. For other entities, it is your employer identification number (EIN). If you do not have a number, see *How to get a TIN*, later.

Note: If the account is in more than one name, see the instructions for line 1. Also see *What Name and Number To Give the Requester* for guidelines on whose number to enter.

Social security number	
[] [] [] - [] [] - [] [] []	
or	
Employer identification number	
2 0 - 2 9 9 3 5 0 3	

Part II Certification

Under penalties of perjury, I certify that:

- The number shown on this form is my correct taxpayer identification number (or I am waiting for a number to be issued to me); and
- I am not subject to backup withholding because: (a) I am exempt from backup withholding, or (b) I have not been notified by the Internal Revenue Service (IRS) that I am subject to backup withholding as a result of a failure to report all interest or dividends, or (c) the IRS has notified me that I am no longer subject to backup withholding; and
- I am a U.S. citizen or other U.S. person (defined below); and
- The FATCA code(s) entered on this form (if any) indicating that I am exempt from FATCA reporting is correct.

Certification instructions. You must cross out item 2 above if you have been notified by the IRS that you are currently subject to backup withholding because you have failed to report all interest and dividends on your tax return. For real estate transactions, item 2 does not apply. For mortgage interest paid, acquisition or abandonment of secured property, cancellation of debt, contributions to an individual retirement arrangement (IRA), and generally, payments other than interest and dividends, you are not required to sign the certification, but you must provide your correct TIN. See the instructions for Part II, later.

Sign Here Signature of U.S. person ▶ *Chris Adams* Date ▶ 1/14/19

General Instructions

Section references are to the Internal Revenue Code unless otherwise noted.

Future developments. For the latest information about developments related to Form W-9 and its instructions, such as legislation enacted after they were published, go to www.irs.gov/FormW9.

Purpose of Form

An individual or entity (Form W-9 requester) who is required to file an information return with the IRS must obtain your correct taxpayer identification number (TIN) which may be your social security number (SSN), individual taxpayer identification number (ITIN), adoption taxpayer identification number (ATIN), or employer identification number (EIN), to report on an information return the amount paid to you, or other amount reportable on an information return. Examples of information returns include, but are not limited to, the following.

- Form 1099-INT (Interest earned or paid)

- Form 1099-DIV (dividends, including those from stocks or mutual funds)
- Form 1099-MISC (various types of income, prizes, awards, or gross proceeds)
- Form 1099-B (stock or mutual fund sales and certain other transactions by brokers)
- Form 1099-S (proceeds from real estate transactions)
- Form 1099-K (merchant card and third party network transactions)
- Form 1098 (home mortgage interest), 1098-E (student loan interest), 1098-T (tuition)
- Form 1099-C (canceled debt)
- Form 1099-A (acquisition or abandonment of secured property)

Use Form W-9 only if you are a U.S. person (including a resident alien), to provide your correct TIN.

If you do not return Form W-9 to the requester with a TIN, you might be subject to backup withholding. See *What is backup withholding*, later.

Certified Pest Control Operator



State of



Florida

Department of Agriculture and Consumer Services
Bureau of Licensing and Enforcement

CERTIFIED PEST CONTROL OPERATOR

Number: JF190298

LONDON TYLER PYLE

This is to Certify that the individual named above is a Certified Pest Control Operator and is privileged to practice

General Household Pest and Rodent Control, Lawn and Ornamental

in conformity with an Act of the Legislature of the State of Florida regulating the practice of Pest Control and imposing penalties for violations.



Adam H. Putnam
Commissioner of Agriculture

In Testimony Whereof, Witness this signature at Tallahassee, Florida on October 16, 2018

Chief, Bureau of Licensing and Enforcement



Certified Arborist



INTERNATIONAL SOCIETY OF ARBORICULTURE
CERTIFIED ARBORIST™

James M. Herth

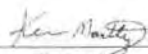
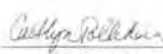
Having successfully completed the requirements set by the
International Society of Arboriculture, the above named
is hereby recognized as an ISA Certified Arborist®

	 Kevin Martlage Director of Credentialing International Society of Arboriculture	 Caitlyn Polihan Executive Director International Society of Arboriculture	 #0847 ISO/IEC 17024 Personnel Certification Program ISA Certified Arborist*
FL-6437A Certification Number	15 Aug 2012 Certified Since	31 Dec 2021 Expiration Date	



YELLOWSTONE
LANDSCAPE

Your Investment

Proposal Form



PACKAGE # 1

Respondent Name (Company): Yellowstone Landscape

Name and Title of Person Completing Form: Landon Pyle, Business Development Manager

PROPOSED COST

Base Maintenance	\$ 89,040.00
Palm Trimming Greater than 13' OA (per tree)	\$ 42.00
Crepe Trimming Greater than 13' OA (per tree)	\$ 205.00
Irrigation Inspections Per Inspection	\$ 385.00
Mulch- Supplied and Installed (per cubic yard)	\$ 45.00
Fertilizer (per application)	\$ 630.00
Integrated Pest Management (per application)	\$ 630.00
PROPOSAL TOTAL	\$ 90,977.00

PLANT, TREE, AND GROUND COVER INSTALLATION

Not to be included as part of proposal review criteria. Price to include all components of installation including staking, watering in, and one-year warranty.

Annuals (Cost plus %)	20 %
Ground cover (Cost plus %)	20 %
Shrubs (Cost plus %)	20 %
Palms (Cost plus %)	27 %
Canopy trees (Cost plus %)	27 %
Understory trees (Cost plus %)	20 %
Sod (Cost plus %)	20 %

Proposal Form



PACKAGE # 2

Respondent Name (Company): Yellowstone Landscape

Name and Title of Person Completing Form: Landon Pyle, Business Development Manager

PROPOSED COST

Base Maintenance	\$ 161,880.00
Palm Trimming Greater than 13' OA (per tree)	\$ 42.00
Crepe Trimming Greater than 13' OA (per tree)	\$ 205.00
Irrigation Inspections Per Inspection	\$ 1,320.00
Mulch- Supplied and Installed (per cubic yard)	\$ 45.00
Fertilizer (per application)	\$ 3,300.00
Integrated Pest Management (per application)	\$ 3,300.00
PROPOSAL TOTAL	\$ 170,092.00

PLANT, TREE, AND GROUND COVER INSTALLATION

Not to be included as part of proposal review criteria. Price to include all components of installation including staking, watering in, and one-year warranty.

Annuals (Cost plus %)	20 %
Ground cover (Cost plus %)	20 %
Shrubs (Cost plus %)	20 %
Palms (Cost plus %)	27 %
Canopy trees (Cost plus %)	27 %
Understory trees (Cost plus %)	20 %
Sod (Cost plus %)	20 %

Proposal Form



PACKAGE # 3

Respondent Name (Company): Yellowstone Landscape

Name and Title of Person Completing Form: Landon Pyle, Business Development Mana

PROPOSED COST

Base Maintenance	\$ 141,960.00
Palm Trimming Greater than 13' OA (per tree)	\$ 42.00
Crepe Trimming Greater than 13' OA (per tree)	\$ 205.00
Irrigation Inspections Per Inspection	\$ 1,128.00
Mulch- Supplied and Installed (per cubic yard)	\$ 45.00
Fertilizer (per application)	\$ 2,858.00
Integrated Pest Management (per application)	\$ 2,858.00
PROPOSAL TOTAL	\$ 149,096.00

PLANT, TREE, AND GROUND COVER INSTALLATION

Not to be included as part of proposal review criteria. Price to include all components of installation including staking, watering in, and one-year warranty.

Annuals (Cost plus %)	20 %
Ground cover (Cost plus %)	20 %
Shrubs (Cost plus %)	20 %
Palms (Cost plus %)	27 %
Canopy trees (Cost plus %)	27 %
Understory trees (Cost plus %)	20 %
Sod (Cost plus %)	20 %

Proposal Form



PACKAGE # 4

Respondent Name (Company): Yellowstone Landscape

Name and Title of Person Completing Form: Landon Pyle, Business Development Manager

PROPOSED COST

Base Maintenance	\$ 36,960.00
Palm Trimming Greater than 13' OA (per tree)	\$ 42.00
Crepe Trimming Greater than 13' OA (per tree)	\$ 205.00
Irrigation Inspections Per Inspection	\$ 330.00
Mulch- Supplied and Installed (per cubic yard)	\$ 45.00
Fertilizer (per application)	\$ 750.00
Integrated Pest Management (per application)	\$ 750.00
PROPOSAL TOTAL	\$ 39,082.00

PLANT, TREE, AND GROUND COVER INSTALLATION

Not to be included as part of proposal review criteria. Price to include all components of installation including staking, watering in, and one-year warranty.

Annuals (Cost plus %)	20 %
Ground cover (Cost plus %)	20 %
Shrubs (Cost plus %)	20 %
Palms (Cost plus %)	27 %
Canopy trees (Cost plus %)	27 %
Understory trees (Cost plus %)	20 %
Sod (Cost plus %)	20 %

Proposal Form



PACKAGE # 5

Respondent Name (Company): Yellowstone Landscape

Name and Title of Person Completing Form: Landon Pyle, Business Development Man

PROPOSED COST

Base Maintenance	\$ 164,880.00
Palm Trimming Greater than 13' OA (per tree)	\$ 42.00
Crepe Trimming Greater than 13' OA (per tree)	\$ 205.00
Irrigation Inspections Per Inspection	\$ 1,430.00
Mulch- Supplied and Installed (per cubic yard)	\$ 45.00
Fertilizer (per application)	\$ 2,860.00
Integrated Pest Management (per application)	\$ 2,860.00
PROPOSAL TOTAL	\$ 172,322.00

PLANT, TREE, AND GROUND COVER INSTALLATION

Not to be included as part of proposal review criteria. Price to include all components of installation including staking, watering in, and one-year warranty.

Annuals (Cost plus %)	20 %
Ground cover (Cost plus %)	20 %
Shrubs (Cost plus %)	20 %
Palms (Cost plus %)	27 %
Canopy trees (Cost plus %)	27 %
Understory trees (Cost plus %)	20 %
Sod (Cost plus %)	20 %

Proposal Form



PACKAGE # 6

Respondent Name (Company): Yellowstone Landscape

Name and Title of Person Completing Form: Landon Pyle, Business Development Manager

PROPOSED COST

Base Maintenance	\$ 41,700.00
Palm Trimming Greater than 13' OA (per tree)	\$ 42.00
Crepe Trimming Greater than 13' OA (per tree)	\$ 205.00
Irrigation Inspections Per Inspection	\$ 330.00
Mulch- Supplied and Installed (per cubic yard)	\$ 45.00
Fertilizer (per application)	\$ 695.00
Integrated Pest Management (per application)	\$ 695.00
PROPOSAL TOTAL	\$ 44,042.00

PLANT, TREE, AND GROUND COVER INSTALLATION

Not to be included as part of proposal review criteria. Price to include all components of installation including staking, watering in, and one-year warranty.

Annuals (Cost plus %)	20 %
Ground cover (Cost plus %)	20 %
Shrubs (Cost plus %)	20 %
Palms (Cost plus %)	27 %
Canopy trees (Cost plus %)	27 %
Understory trees (Cost plus %)	20 %
Sod (Cost plus %)	20 %

Proposal Form (Continued)



PACKAGE # All Packages

TREE REMOVAL AND STUMP GRINDING

Not to be included as part of the proposal review criteria. Price to include back fill/sod if needed.

Tree removal 6"	\$ 600.00
Tree removal 12"	\$ 875.00
Tree removal 18"	\$ 1,045.00
Tree removal 24"	\$ 1,530.00
Tree removal 36"	\$ 1,875.00

IRRIGATION REPAIR

Not to be included as part of proposal review criteria unless otherwise noted.

Wholesale price of materials plus proposed percentage	20 %
Irrigation Technician Hourly Rate	\$ 55.00

Signature of person completing form:



CONSENT AGENDA ITEM 303

CITY COMMISSION AGENDA | NOVEMBER 18, 2019 | REGULAR MEETING

TITLE

Engineering Services for Priority Repairs at City Wastewater Treatment Plants

SUMMARY

The City's two wastewater treatment plants were constructed in the 1970s and 1980s and are reaching their useful service lives. Staff has been evaluating options for major repairs, replacement, or even elimination. It will take several years to complete the design, permitting, secure financing, and then complete the construction of new wastewater treatment plants. Immediate mechanical repairs are needed for the current facilities to operate efficiently and maintain compliance while capital decisions are being made.

As part of the priority repairs at the City's two wastewater treatment plants, engineering services are needed for the installation of fine influent screens, replacement of the aeration system, metal repairs, and replacement of valves. A proposal by CPH, Inc. for this scope of work is included as Attachment 1. The cost for these services is \$96,151.48 and has been appropriated in the FY2020 capital budget in the Utility Enterprise Fund. CPH, Inc. was approved as an Engineering Continuing Services Consultant on December 8, 2014 under Consent 300 in response to RFQ #001/15/BF.

RECOMMENDATION

Staff recommends the City Commission authorize CPH, Inc. to provide Engineering Services for priority repairs at the City's two wastewater treatment plants in the amount of \$96,151.48 from the Utility Enterprise Fund. Additionally, authorization for the City Manager and City Attorney is requested to prepare and execute any and all applicable contract documents consistent with this Agenda item.



November 12, 2019

Ms. Lena Rivera, P.E.
Public Works and Utility Director
City of Winter Springs
1126 East State Road 434
Winter Springs, FL 32708

1117 East Robinson Street
Orlando, Florida 32801
Phone: 407.425.0452
Fax: 407.648.1036
www.cphcorp.com

RE: City of Winter Springs East and West Water Reclamation Facility Rehabilitation Project

Dear Ms. Rivera:

CPH is pleased to submit this proposal for Engineering services associated with the East and West Water Reclamation Facility Rehabilitation Project. CPH received a scope of work and timetable/schedule from Veolia. The engineering services listed in Exhibit A are incorporated herein. These two items are attached as Exhibit A. CPH understands that the City is looking to have this work performed and a plan developed as quickly as possible and we commit to the schedule provided.

SCOPE OF SERVICES

Based on our meeting at City Hall, November 7, 2019, the written scope from Veolia and our field visit to the East Water Reclamation Facility (East WRF) with Veolia officials on November 7, 2019, we have made the following assumptions in our preparation of the fee estimate for this Project:

- 1) Our design effort is based on the equipment described by Veolia. We will not investigate other manufacturers or types of equipment during the design phase.
- 2) We will design an enclosed chute to carry the screenings down to a dumpster. We will address the access issues for dumpster pickup in our design.
- 3) We will address access issues around the screen in accordance with the manufacturers and the operations maintenance personnel requirements in order to perform routine observation and maintenance.
- 4) During the investigation phase, rehabilitation items will be categorized with an emphasis on the "process" and "safety" issues having the highest repair priority.
- 5) Since the systems will be operational during our field investigations, we will not be able to assess conditions below the water level. Repairs will be described in unit pricing terms to allow flexibility in the amount of work that can be performed. A reasonable estimate of quantities will be made based on the visual inspection.
- 6) Existing facility surfaces will not be cleaned or sand blasted and recoated. Cleaning, sand blasting and coating will be performed where repairs are made to the baffle walls, miscellaneous steel and structural steel. New structures and plate steel will be coated as required or recommended by the manufacturer.
- 7) We are not providing a structural analysis of the existing structures. Our structural analysis will be performed only for the support of the new screens and associated piping and chutes.
- 8) We have assumed that the new equipment described does not have any electrical requirements.
- 9) We have assumed, based on the Veolia scope, that there are no electrical items in the rehabilitation. We have not provided for any electrical design services.



SUPPLEMENTARY SERVICES

If authorized in writing by the Owner, and prior to the rendering of such services, the engineer will furnish or obtain under subcontracts, supplementary services of the following types which will be paid for by the Owner:

- Additional services due to significant changes in the scope of the project or its design including, but not limited to, changes in size, complexity, character of construction or due to time delays in initiating or completion of the work as described herein.
- Preparing to serve as an expert witness for the Owner in any protest, litigation, or other proceeding involving the project.
- Additional engineering services required by revisions to regulations (after the date of this contract) as applicable to the Florida Department of Environmental Protection, the St. Johns River Water Management District, or other regulatory agency requirements.
- Provide, through a subconsultant, soils, electrical, or surveying, additional services if required or requested by the Owner.

PAYMENT

Compensation paid Engineer for services described herein and rendered by principals and employees assigned to the project are computed by multiplying Standard Classification Billing Rates for all classifications of employees directly engaged on the project, times the number of hours worked on the project.

The Engineering Hourly Not-To-Exceed fee for the services described herein is estimated to be **\$96,151.48**. The attached Exhibit B provides an estimated man-hour break down and associated cost to perform the services as outlined. The fee includes out-of-pocket expenses and will be specifically identified in periodic invoicing, and include such items as transportation and subsistence of principals and employees when traveling in connection with the project, tolls, telephone calls, photocopies, blueprints and plots, etc. Invoices will be submitted periodically, indicating the hours expended during that billing cycle. Progress invoices will be submitted based on the Engineer's time spent for the billing period. Expenses for items not specifically valued herein are to be reimbursed to the engineer at the actual cost thereof.

Charges for the services rendered by principals and employees as witnesses in any litigation, hearing or proceeding in accordance with this Contract will be computed at a rate of \$1,200 per day or any portion thereof.

If this Contract is terminated during prosecution of the services prior to completion of the services, payments to be made on account of that and all prior work under this Contract shall be due and payable, and shall constitute total payment for services rendered. In addition, upon termination, engineer shall be paid for any Supplementary Services authorized and rendered.



If you are in agreement with the terms and fees proposed, please sign on the space provided below and return one (1) copy to us, or provide us with the purchase order for CPH to begin work on the project.

Sincerely,
CPH ENGINEERS, INC.

A handwritten signature in blue ink, appearing to read "D. Mahler", is written over the company name.

David E. Mahler, P.E.
Sr. Vice President

RE: City of Winter Springs East and West Water Reclamation Facility Rehabilitation Project

City of Winter Springs

Date

J:\Z6582\Proposals\Winter Springs\WRF Rehab 2019-2020\CPH Scope of Work for Rehab.doc

Exhibit A

Description of Project and Consultant Services 11-08-19

1. Project Description

The City of Winter Springs proposes to perform priority repairs to their East and West Water Reclamation Facilities (WRF). It is the intention of the City to effect these repairs as quickly and efficiently as possible while providing the best value for the Citizens. The following represents a brief listing of the known repairs required and is not intended to be complete and comprehensive:

West WRF (both plant 1 and 2)

- Demo screening equipment and replace with Parkson Hycor Hydroscreening equipment. Reuse/replace structural support as needed.
- Repair corroded existing internal baffle systems.
- Rehab RAS airlift piping.
- Install new Sanitaire diffuser equipment.
- Repair/level existing clarifiers.
- Rehab influent feed troughs
- Provide chemical feed to clarifiers for Alum and Polymer
- Provide a solution for the underground air leaks at both plants.

East WRF

Install new Parkson Hycor Hydroscreen adjacent to existing screen/flow splitter on plant #2. Provide new supporting structure adjacent to existing structure. Route influent through new screen and utilize existing splitter box to continue splitting flows between plants 1 and 2 as currently provided.

Scope identical to both Plant #1 and Plant #2.

- Repair corroded existing internal baffle systems.
- Rehab RAS airlift piping.
- Install new Sanitaire diffuser equipment.
- Repair/level existing clarifiers.
- Rehab influent feed troughs
- Provide chemical feed to clarifiers for Alum and Polymer
- Provide a solution for the underground air leaks at both plants.

2. Engineering Design Phase Services

Task 1- Pre-Design

- Attend 1 project kickoff meeting to discuss overall project objectives.
- Provide site boring(s) if deemed necessary regarding new support structures.
- Provide survey services if deemed necessary to support site needs and verify key as-built conditions.

- Attend 1 meeting with the City, FDEP and Veolia to discuss potential permitting requirements.

Task 2- General Field Evaluations

- Provide evaluations of existing plant conditions.
 - Evaluate all tankage baffle systems. Develop unit price repair types.
 - Evaluate influent feed troughs. Develop unit price repair types.
 - Evaluate current clarifier alignment and recommend repairs.
 - Evaluate all diffuser systems including existing blowers and pipe distributions systems. The blowers are not currently listed for replacement.

Task 3- Design Phase-30%

- Develop the design to a 30% level.
 - Provide general hydraulic design review of Parkson Hycor equipment to allow the City to draft preliminary procurement documents. Preliminary sizing of Parkson equipment.
 - Provide general review and conceptual sizing of new diffuser systems to include recommendations of fine bubble diffusion equipment/systems.
 - Provide general equipment layout configuration.
 - Provide preliminary structural development.
 - Provide preliminary clarifier repair plan. Include basic sketches with narratives.
 - Develop unit price repair types for baffles/and influent troughs.
 - Provide preliminary chemical feed tie in and routing details for addition of Alum and Polymer to the clarifiers.
 - Provide preliminary specifications.
 - Provide Engineers Opinion of Probable cost 30%.
 - Submittal of the preliminary package to the City and schedule/attend a review meeting and follow-up with minutes and responses to confirm/address any questions from the City, incorporate any agreed to changes in the design documents.

Task 4- Design Phase-75-90%

- Develop the design to a 75-90% level.
 - Finalize hydraulic review of influent piping configuration changes along with final sizing of screening equipment.
 - Finalize hydraulic/process review of air distribution systems. Provide layout of air diffusion system.
 - Provide supporting calculations/information demonstrating expected oxygen transfer performance, required CFM, and existing CFM capacity.
 - Provide complete process equipment specification with layout details sufficient to perform an advanced procurement of the Parkson Hycor screens (3 ea.).
 - Provide final equipment layout configuration.

- Provide final structural development, drawings.
- Provide final specifications.
- Provide final details showing unit price repair types for baffle walls and influent feed troughs.
- Provide Engineers Opinion of Probable cost 75-90%
- Submittal of the 75-90% package to the City and schedule/attend a review meeting and follow-up with minutes and responses to confirm/address any questions from the City.

Task 5- Design Phase-100% IFC

- Finalize drawings and specifications
 - Incorporate any agreed to changes in the design documents from the 75-90% design review. This issue will be distributed as a 100% Draft. Upon concurrence that all changes have been incorporated, the 100% design drawings and specifications shall be issued as stamped and sealed 100% IFC.
- Prepare applications for and coordinate any required regulatory permits and approvals including City of Winter Springs, and FDEP.

3. Construction Phase Services

Task 1- Submittal reviews

- Provide submittal reviews for:
 - Screening equipment.
 - Diffuser equipment.
 - Structural steel shop drawings.
 - Concrete and reinforcing steel shop drawings.

Task 2- RFI responses

- Provide RFI responses as necessary through the construction period.
 - Assume 20 RFI's.
 - Assume 3 site visits to review complex RFI's.

Task 3- Meetings/ Requested Site Visits

- Attend meetings through the construction period.
 - Assume 6 meetings. (1 meeting every 2 months over a 10 month period)

4. Schedule

A brief summary of the overall priority projects is provided below. It is critical that the Engineer meet all dates.

Winter Springs Contract NTP	October 28, 2019
Engineering Phase	
Review Engineering Scope of Work with Engineer	November 7, 2019
Engineer submits pricing to Winter Springs	November 11, 2019
Negotiate Engineering Proposal	November 12, 2019
Engineering proposal – Final pricing determined	November 13, 2019
Agenda item prepared and submitted	November 13, 2019
Commission meeting – Engineering approval	November 18, 2019
Engineering NTP	November 19, 2019
Kickoff meeting with Engineer	November 20, 2019
30% Design submittal	December 20, 2019
75-90% Design submittal	January 23, 2020
Finalize Equipment (Parkson) PO Package	January 28, 2020
100% Design IFC submittal	February 14, 2020
Construction Phase	
Issue NTP to Construction Contractor	March 16, 2020
West Plant construction Mobilization	April 30, 2020
West Plant construction completion	October 30, 2020
East Plant construction mobilization	May 7, 2020
East Plant construction completion	December 18, 2020
Overall project completion	December 28, 2020

Exhibit B

TABLE 1
SUMMARY OF FEES
WINTER SPRINGS WWTP REPAIRS

Item Description	TOTAL
Task 1 - Pre-Design	\$13,405.00
Task 2 - General Field Evaluations	\$12,141.55
Task 3 - Design Phase - 30%	\$30,378.50
Task 4 - Design Phase - 75-90%	\$12,678.50
Task 5 - Design Phase - 100% IFC	\$8,404.20
Construction Phase Services	\$19,143.73
TOTAL HOURLY NOT-TO-EXCEED FEE FOR ENGINEERING SERVICES	\$96,151.48

Including subconsultants

TABLE 2a
MANHOUR & COST ESTIMATES
Task 1 - Pre-Design
WINTER SPRINGS WWTP REPAIRS

Task Number	Task Description	Sr. Project Manager	Project Engineer	Sr. Design Technician	Administrative	One Man Scanner Crew	GPS (1 man) / Robotics	Senior Survey CADD Tech	TOTALS
1.1	Data Collection								
1.1.a	Attend Kick-off meeting.	3							3
1.1.b	Collect and review available information on the existing structures. Obtain Record drawings of the four (4) wastewater treatment plants.	2	8		1				11
1.1.c	Review previous inspection and condition assessment reports and recommendations								0
1.1.d	Attend meeting with City, FDEP and Veolia to discuss potential permitting requirements.	2							2
1.2	Soil Borings								0
1.2.a	Retain the services of a geotechnical engineer for one boring for the screen at the East WRF and one each for the screens at the West WRF. See subconsultant fee below.	1							1
1.3	Survey								
1.3.a	Perform a laser scan of each WWTP from the top walkway and develop a plan view of each wastewater treatment plant.	1			1	16	8	16	42
1.3.b	Perform a laser scan of the three screen locations. This will serve as a vertical and horizontal verification of the existing piping, catwalks, splitter/diversion boxes, stairways and columns.	Included in the above.							0
Total Manhours - Task 1 - Preliminary Engineering Services		9	8	0	2	16	8	16	59
Billing Rate (\$/hr)		\$180.00	\$120.00	\$105.00	\$75.00	\$265.00	\$145.00	\$110.00	
Total Labor Cost		\$1,620.00	\$960.00	\$0.00	\$150.00	\$4,240.00	\$1,160.00	\$1,760.00	\$9,890.00
Other Direct Cost (See Table 3)									\$15.00
Subconsultant Fees - geotechnical									\$3,500.00
TOTAL COST - TASK 1 - Pre-Design									\$13,405.00

TABLE 2b
MANHOUR & COST ESTIMATES
Task 2 - General Field Evaluations
WINTER SPRINGS WWTP REPAIRS

Task Number	Task Description	Sr. Project Manager	Project Engineer	Sr. Design Technician	Administrative	One Man Scanner Crew	GPS (1 man) / Robotics	Senior Survey CADD Tech	TOTALS
2.1	Provide evaluation of existing WWTP conditions								
2.1.a	Field investigation/visits to East and West WRFs. Documentation of visual items (i.e., no tank draining) with pictures and field notes.	8							8
2.1.b	Identification of each observed anomaly or deficiency. Prepare a written memorandum that includes photos of our observations. The memo shall cover the items listed below.	8	8		2				18
2.1.c	Advise the client of all observed anomalies and assist the OWNER in prioritizing each one.	2							2
2.2	Evaluate each tank baffle systems from the surface, i.e. no tank draining.								0
2.2.a	Based on field observations of the exposed walls and baffles, develop "types" of repairs needed and recommendations. Types will include: 1) Plate/sheet steel replacement; 2) support column repair/replacement; and, 3) cross-member repair/replacement	4	4						8
2.3	Evaluate influent feed troughs								0
2.3.a	Based on field observations of the exposed troughs, develop "types" of repairs needed and recommendations. Determine an estimate on the length of repair. This will be a plate/sheet steel repair/replacement item.	4	4		1				9
2.4	Evaluate current clarifier alignment and recommend repairs. East WRF - WWTP1 only	2							2
2.5	Evaluate all diffuser systems including existing blowers and pipe distribution systems. The blowers are not currently listed for replacement.	6	8		1				15
2.5.a	Based on field observations of the exposed air header and down pipe distribution system, develop "types" of repairs needed and recommendations. This will include repairs to the air header, the individual downcomer isolation valves, the individual downcomer piping and the air header support system.	4	4						8
2.5.b	Obtain blower information from the manufacturer for the existing installed models and determine the operating parameters for the existing blowers.	See 2.5							0
2.5.c	Determine, by physical observation, the condition of the blowers.	2							2
2.5.d	Work with the Sanitaire representatives and determine if the existing blowers are compatible with the "fine" bubble difusers desired. Can the existing blowers provide the required air flow and pressure needed for a new fine bubble system?	4	4						8
Total Manhours - Task 2 -General Field Evaluation		44	32	0	4	0	0	0	80
Billing Rate (\$/hr)		\$180.00	\$120.00	\$105.00	\$75.00	\$265.00	\$145.00	\$110.00	
Total Labor Cost		\$7,920.00	\$3,840.00	\$0.00	\$300.00	\$0.00	\$0.00	\$0.00	\$12,060.00
Other Direct Cost (See Table 3)									\$81.55
Subconsultant Fees (See Table 3)									\$0.00
TOTAL COST - TASK 2 - General Field Evaluations									\$12,141.55

TABLE 2c
MANHOUR & COST ESTIMATES
Task 3 - Design Phase - 30%
WINTER SPRINGS WWTP REPAIRS

Task Number	Task Description	Sr. Project Manager	Project Engineer	Sr. Design Technician	Administrative	One Man Scanner Crew	GPS (1 man) / Robotics	Senior Survey CADD Tech	TOTALS
3.1	Develop the design to a 30% level.								
3.1.a	Obtain, from OWNER, detailed flow information on peak hour flows to each WRF. Work with OWNER to determine the impact of the East WRF flow equalization system on the peak flows. Based on this information, provide general hydraulic design review of Parkson Hycor equipment to allow the City to draft procurement documents.	1	4						5
3.1.b	Provide varification of preliminary sizing of Parkson headworks equipment as selected.	1	2						3
3.1.c	Provide general review and conceptual sizing of the Sanitaire fine bubble diffuser system(s). See also plan sheets below.	See 2.5.d							0
3.1.d	Provide general equipment layout configuration. See plan sheets below.	1	4						5
3.1.e	Provide preliminary structural development of the East WRF Hycor screen foundation and structural support system. See plan sheets below. This is for structural design.	8							8
3.1.f	Preliminary clarifier repair plan for East WRF WWTP 1 information to be identified on plan sheets below.	See 2.4							0
3.1.g	Develop "unit price" repair "types" for baffles and influent troughs.	2	4						6
3.1.h	Provide preliminary chemical feed tie-in and routing details for the addition of alum and polymer to the clarifier influent pipe. See piping sheets below.	1	2						3
3.1.i	Provide preliminary technical specifications.	1	4						5
3.1.j	Provide Engineers Opinion of Probable cost at 30% level.	2	4						6
3.1.k	Prepare and submit preliminary package to the City.	1		2	2				5
3.1.l	Schedule and attend a review meeting and provide minutes and responses to confirm/address any questions from the City. Incorporate any agreed to changes in the design documents.	4			2				6
3.2	Provide 30% Plan sheets								0
3.2.a	Cover Sheet	1	1	2					4
3.2.b	General Notes sheet	1		2					3
3.2.c	East existing site plan sheet		2	4					6
3.2.d	West existing site plan sheet		2	4					6
3.2.e	Hydraulic Profiles for influent configuration (1 sheet). Three profiles	3	4	4					11
3.2.f	East Proposed piping Plan - liquid and air piping	1	4	4					9
3.2.g	West Proposed piping Plan- liquid and air piping	2	6	8					16
3.2.h	Steel and other Repairs sheet using plant layouts and pictures with descriptions of work. (4 plants, 4 sheets)	4	6	16					26
3.2.i	Diffuser layout sheets (4 plants, 4 sheets)	1	2	4					7
3.2.j	East and West screen mechanical design and drop chutes (1 sheet)	4	9	12					25
3.2.k	East Screen Structural plan and details (2 sheets)	12		16					28
3.2.l	West Screen Structural plan and details (2 sheets)	8		12					20
3.2.m	Repair Welding details sheet, procedures and specification notes	8		12					20
Total Manhours - Task 3 - Design Phase - 30%		67	60	102	4	0	0	0	52
Billing Rate (\$/hr)		\$180.00	\$120.00	\$105.00	\$75.00	\$265.00	\$145.00	\$110.00	
Total Labor Cost		\$12,060.00	\$7,200.00	\$10,710.00	\$300.00	\$0.00	\$0.00	\$0.00	\$30,270.00
Other Direct Cost (See Table 3)									\$108.50
Subconsultant Fees (See Table 3)									
TOTAL COST - TASK 3 - Design Phase -30%									\$30,378.50

TABLE 2d
MANHOUR & COST ESTIMATES
Task 4 - Design Phase - 75-90%
WINTER SPRINGS WWTP REPAIRS

Task Number	Task Description	Sr. Project Manager	Project Engineer	Sr. Design Technician	Administrative	One Man Scanner Crew	GPS (1 man) / Robotics	Senior Survey CADD Tech	TOTALS
4.1	Develop the design to a 75-90% level								
4.1.a	Finalize the hydraulics of influent piping configuration and screen along with final sizing of the screening equipment.	1	2						3
4.1.b	Finalize hydraulic/process review of air distribution systems. Provide layout of the diffusers in a plan view of the treatment plant. See plan sheets below.	2							2
4.1.c	Work with Sanitaire to provide supporting calculations/information demonstrating expected oxygen transfer performance, required CFM and existing CFM capacity.	1							1
4.1.d	Provide final process equipment technical specification with layout details sufficient to perform an advanced procurement of the Parkson Hycor screens (three separate units).	2	2						4
4.1.e	Provide final equipment layout configuration. See plan sheets below.								0
4.1.f	Provide final structural development drawings. See plan sheets below.								0
4.1.g	Provide final specifications.	2	4						6
4.1.h	Provide final details showing unit price repair types for baffle walls and influent troughs. See Plan sheets below.								0
4.1.i	Provide Engineers Opinion of Probable cost 75-90%.	2	2						4
4.1.j	Prepare and submit 75-90% package to the City.			1	1				2
4.1.k	Schedule and attend a 75-90% review meeting and provide minutes and responses to confirm/address any questions from the City. Incorporate any agreed to changes in the design documents.	2			1				3
4.2	Provide 75-90% Plan sheets								0
4.2.a	Cover Sheet								0
4.2.b	General Notes sheet		1	1					2
4.2.c	East existing site plan sheet	1		1					2
4.2.d	West existing site plan sheet	1		1					2
4.2.e	Hydraulic Profiles for influent configuration (1 sheet). Three profiles	See 3.2.e							0
4.2.f	East Proposed piping Plan - liquid and air piping	1	2	4					7
4.2.g	West Proposed piping Plan- liquid and air piping	1	4	6					11
4.2.h	Steel and other Repairs sheet using plant layouts and pictures with descriptions of work. (4 plants, 4 sheets)	2	6	12					20
4.2.i	Diffuser layout sheets (4 plants, 4 sheets) Finalize.	1		2					3
4.2.j	East and West screen mechanical design (2 sheets)	1		4					5
4.2.k	East Screen Structural plan and details (2 sheets)	3		4					7
4.2.l	West Screen Structural plan and details (2 sheets)	3		4					7
4.2.m	Welding repair detail sheet, procedures and specification notes	2		4					6
Total Manhours - Task 4 - Design Phase		28	23	44	2	0	0	0	97
Billing Rate (\$/hr)		\$180.00	\$120.00	\$105.00	\$75.00	\$265.00	\$145.00	\$110.00	
Total Labor Cost		\$5,040.00	\$2,760.00	\$4,620.00	\$150.00	\$0.00	\$0.00	\$0.00	\$12,570.00
Other Direct Cost (See Table 3)									\$108.50
Subconsultant Fees (See Table 3)									\$0.00
TOTAL COST - TASK 4 - Design Phase -75-90%									\$12,678.50

TABLE 2e
MANHOURLY & COST ESTIMATES
Task 5 - Design Phase - 100% IFC
WINTER SPRINGS WWTP REPAIRS

Task Number	Task Description	Sr. Project Manager	Project Engineer	Sr. Design Technician	Administrative	One Man Scanner Crew	GPS (1 man) / Robotics	Senior Survey CADD Tech	TOTALS
									0
5.1	Design Phase 100%								0
5.1.a	Finalize drawings and specifications: Incorporate any agreed to changes in the design documents from the 75-90% design review. This issue will be distributed as a 100% Draft. Upon occurrence that all changes have been incorporated, the 100% design drawings and specifications shall be issued as stamped and sealed 100% IFC.	4	4	16					24
5.2	Permitting								
5.2.a	Prepare applications for and coordinate any required regulatory permits and approvals including City of Winter Springs and FDEP. See below.								0
5.2.b	Prepare and submit documents to the City of Winter Springs for a building permit. This is an electronic submittal.	4	4	4					12
5.2.c	Prepare and submit documents to FDEP for two minor modification construction permits (One for each WRF). These are electronic submittals. Submit clearance request and plans following construction.	8	16	4					28
Total Manhours - Task 5 - Preparation of Construction Docs		16	24	24	0	0	0	0	64
Billing Rate (\$/hr)		\$180.00	\$120.00	\$105.00	\$75.00	\$265.00	\$145.00	\$110.00	
Total Labor Cost		\$2,880.00	\$2,880.00	\$2,520.00	\$0.00	\$0.00	\$0.00	\$0.00	\$8,280.00
Other Direct Cost (See Table 3)									\$124.20
Subconsultant Fees (See Table 3)									\$0.00
TOTAL COST - Task 5 - Preparation of Construction Documents									\$8,404.20

Note: 1) FDEP minor modification permit is required for the anticipated work. The \$500 application fee shall be paid by the OWNER.
2) The Winter Springs building permit fee shall be paid by others.

**TABLE 3
MANHOUR & COST ESTIMATES
Construction Phase Services
WINTER SPRINGS WWTP REPAIRS**

Task Number	Task Description	Sr. Project Manager	Project Engineer	Sr. Design Technician	Administrative	One Man Scanner Crew	GPS (1 man) / Robotics	Senior Survey CADD Tech	TOTALS
1	Submittal Reviews								0
1.1	Provide Submittal reviews for : screening equipment; diffuser equipment; structural steel shop drawings; concrete; and, reinforcing steel shop drawings. Estimate four (4) submittals.	4	16		4				24
2	RFI Responses								0
2.1	Provide RFI responses, as necessary, through the construction period for 20 RFI's.	20	40		20				80
2.2	Three (3) site visits to review complex RFI's.	3	12						15
3	Meetings/Requested Site Visits								0
3.2	Attend meetings through the construction period. Six (6) meetings; 1 meeting every two months over a ten (10) month period.	12	12		6				30
Total Manhours - Construction Phase Services		39	80	0	30	0	0	0	149
Billing Rate (\$/hr)		\$180.00	\$120.00	\$105.00	\$75.00	\$265.00	\$145.00	\$110.00	
Total Labor Cost		\$7,020.00	\$9,600.00	\$0.00	\$2,250.00	\$0.00	\$0.00	\$0.00	\$18,870.00
Other Direct Cost (See Table 3)									\$273.73
Subconsultant Fees (See Table 3)									\$0.00
TOTAL COST - CONSTRUCTION ADMINISTRATION SERVICES									\$19,143.73

**TABLE 4
SUMMARY OF OTHER DIRECT COSTS
WINTER SPRINGS WWTP REPAIRS**

Unit Description	Unit Cost	Unit	Task 1		Task 2		Task 3		Task 4		Task 5		Construction	
			Quantity	Cost	Quantity	Cost	Quantity	Cost	Quantity	Cost	Quantity	Cost	Quantity	Cost
Reproduction (in-house)														
B&W Copies (8.5x11)	\$0.05	EA	100	\$5.00	250	\$12.50	250	\$12.50	250	\$12.50	500	\$25.00	100	\$5.00
B&W Copies (11x17)	\$0.20	EA	50	\$10.00		\$0.00		\$0.00		\$0.00	16	\$3.20		\$0.00
Blackline Copy (24x36)	\$0.96	EA		\$0.00		\$0.00	100	\$96.00	100	\$96.00	100	\$96.00	50	\$48.00
Miscellaneous														
Digital Camera	\$10.00	Use		\$0.00	2	\$20.00		\$0.00		\$0.00		\$0.00		\$0.00
mileage	\$0.55	mile		\$0.00	90	\$49.05		\$0.00		\$0.00		\$0.00	405	\$220.73
				\$0.00		\$0.00		\$0.00		\$0.00		\$0.00		\$0.00
				\$0.00		\$0.00		\$0.00		\$0.00		\$0.00		\$0.00
				\$0.00		\$0.00		\$0.00		\$0.00		\$0.00		\$0.00
Subtotal Cost per Phase (in-house Other Direct Costs)				\$15.00		\$81.55		\$108.50		\$108.50		\$124.20		\$273.73
Total Other Direct Costs (rounded to the nearest dollar)													\$711.00	



CITY COMMISSION

REGULAR MEETING MINUTES

MONDAY, OCTOBER 14, 2019 AT 6:30 PM

CITY HALL - COMMISSION CHAMBERS
1126 EAST STATE ROAD 434, WINTER SPRINGS, FLORIDA

CALL TO ORDER

The Regular Meeting of Monday, October 14, 2019 of the City Commission was called to Order by Mayor Charles Lacey at 6:30 p.m. in the Commission Chambers of the Municipal Building (City Hall, 1126 East State Road 434, Winter Springs, Florida 32708).

Roll Call:

Mayor Charles Lacey, present
Deputy Mayor Kevin Cannon, present
Commissioner Jean Hovey, present
Commissioner Ted Johnson, present
Commissioner TiAnna Hale, present
Commissioner Geoff Kendrick, present
City Manager Shawn Boyle, present
City Attorney Anthony A. Garganese, absent
Senior City Attorney Kristin Eick, present
City Clerk Andrea Lorenzo-Luaces, present

A moment of silence was held, followed by the Pledge of Allegiance.

Regarding the Agenda, Mayor Lacey said to the City Commission, "May we adopt the Agenda as presented?" Deputy Mayor Kevin Cannon noted that he wanted to address Informational Agenda Item "201." Commissioner Geoff Kendrick added that he wished to speak on Consent Agenda Item "301" to which Deputy Mayor Cannon said that he also wanted to comment on that Agenda Item.

AWARDS AND PRESENTATIONS

100. Seminole County Property Appraiser David Johnson to provide a Presentation related to current market and trends.

Mr. David Johnson, Seminole County Property Appraiser addressed the Mayor and City Commission on median home prices, exemptions, and pointed out that approximately eighty-six percent (86%) of the City of Winter Springs was considered residential, with the rest being commercial.

Continuing, Mr. Johnson reviewed some of the different levels between commercial and residential in the various cities of Seminole County, and pointed out that there were approximately 1,900 apartments units in Winter Springs in comparison to the total of about 36,000 for all of Seminole County.

Furthermore, Mr. Johnson addressed the remaining developable land in Winter Springs, demands for housing, the quality of life in Winter Springs as well as Seminole County, and home sales.

Mayor Lacey inquired when data would be compiled for 2020 to which Mr. Johnson suggested around March 2020. Next, regarding when a property would be added to tax rolls, Mr. Johnson explained that it was when property was deemed “substantially complete” and usually determined through the inspections process.

Discussion ensued on workforce housing, value ranges, and Mr. Johnson explained that spending no more than thirty percent (30%) of one’s income was considered a gauge related to workforce housing price points.

Further remarks followed on apartments, that very few apartments being built in Seminole County would be considered as workforce housing, new projects planned for Seminole County, multi-family projects, a new hospital facility in Lake Mary, density, the former golf course near the Highlands community, sizes of residences, workforce housing, occupancy levels, investors, and that Mr. Johnson could possibly provide City Staff with data regarding which properties were homesteaded and which were not.

CRA’s (Community Redevelopment Agency) were addressed next and Mr. Johnson suggested that City Staff could get with Seminole County on any possible opportunities and potential partnerships.

101. Presentation of Lifesaving Awards to Officer Kyle Harrop, Officer Jesus Hilerio, Officer Jacob Holcomb, Officer Christopher Roland, and Sergeant Shaun Philbrook.

Chief of Police Chris Deisler spoke of opioid challenges in Seminole County and commended the recent valuable lifesaving efforts by Winter Springs’ Officer Kyle Harrop, Officer Jacob Holcomb, Officer Christopher Roland, Sergeant Shaun Philbrook, and Officer Andrew Jones.

Those present received awards and were personally commended by the Mayor and City Commission.

102. Presentation from the Winter Springs Performing Arts Center

Mr. Michael Radka addressed the Mayor and City Commission on plans for a Winter Springs Performing Arts Center, and an anonymous large donation they received which allowed property to be purchased. Mr. Radka further commented on potential fundraising conversations, the desire to bring value to our community, as well as the importance of listening.

Mayor Lacey mentioned he thought this proposed project was needed to complete the Town Center, and that overall, he felt the City Commission was supportive of such an effort. Deputy Mayor Cannon and Commissioner Kendrick both spoke of their support for such a concept.

Commissioner Ted Johnson complimented Mr. and Mrs. Batchelor for their particular efforts with some special needs children.

INFORMATIONAL AGENDA

200. Current Development Projects Update

There was no discussion on this Agenda Item.

201. Consideration for Merging Bicycle and Pedestrian Advisory Committee With Parks and Recreation Advisory Committee

Deputy Mayor Cannon spoke of many bicycle, pedestrian issues, and said that he was not in favor of merging the two (2) Committees as suggested in the Agenda Item, and commented on some bicycle and pedestrian related matters that he thought should be addressed.

Along these lines, Deputy Mayor Cannon noted some concerns with the area near Barrington Estates, missing sidewalks, an area near Vistawilla Drive and the Cross Seminole Trail, problems he was aware of on Hayes Road, Moss Road, and Edgemon Avenue. Deputy Mayor Cannon then suggested adding button access like there is on Aloma Avenue, recent Appointments, and also mentioned a recent accident that involved a bicycle near the Parkstone community.

Deputy Mayor Cannon thought the Parks and Recreation Advisory Committee had enough to do, and added that bicyclists often don't stop.

Commissioner Kendrick spoke of his previous service on the Parks and Recreation Advisory Committee, said he would like to hear from Staff, and was supportive of what would work best.

Commissioner TiAnna Hale mentioned that she recently attended a Seminole County Initiative called "Best Foot Forward" and noted that it focused on engineering, enforcement, and education; and remarked that we should provide more awareness on crosswalk safety.

Further brief remarks.

Mr. Chris Caldwell, Director, Parks and Recreation Department and Mr. Christopher Schmidt, Director, Community Development Department explained what their plans were.

Deputy Mayor Cannon suggested that he could forward complaints that he had received to the City Manager, and thought the other Commissioners could do the same.

Commissioner Jean Hovey asked that should this happen, would additional Members be added to the Parks and Recreation Advisory Committee or would the Bicycle and Pedestrian Advisory Committee Members be absorbed?

Mr. Caldwell stated, "Absorb and the natural attrition would take place, but we would combine the groups together and the natural attrition is where some folks don't want to get reappointed again - choose not to be reappointed and then it would slowly reduce that number to where it's more of a manageable group. They would be absorbed."

Commissioner Hovey then inquired if Staff had contacted the Chairperson of the Parks and Recreation Advisory Committee, to which Mr. Caldwell said they had not yet, as they wanted to advise the Mayor and City Commission first. Commissioner Hovey suggested that Staff speak with the Chairperson of the Parks and Recreation Advisory Committee and then advise the City Commission.

Next, Commissioner Kendrick referenced the planned upcoming quarterly meetings, agreed with Commissioner Hovey's suggestion that Chairperson Nussbaum be contacted, concurred with Deputy Mayor Cannon that comments from residents be forwarded to Manager Boyle, and thought this could be readdressed further next year.

In other City business, Mayor Lacey referenced the missing link near Layer Elementary School and a planned completion date. In terms of trying to expedite this matter, Deputy Mayor Cannon noted, "If there's anything we can do - if it is the Consensus of the Commission, I would like to ask a letter be sent by our City Manager to the County Manager saying, can we try and move that along faster."

Mayor Lacey inquired, "Is it the Consensus that we ask Shawn (Boyle) to write a letter to Nicole Guillot?" Commissioner Kendrick stated, "Absolutely." Members of the City Commission nodded in agreement. Deputy Mayor Cannon added, "If you could Shawn (Boyle, City Manager)." No objections were voiced.

PUBLIC INPUT

Mayor Lacey opened "Public Input".

Ms. Gina Shafer, Winter Springs Village, Winter Springs, Florida: asked the City Commission to consider changing an Ordinance related to the length of time that vehicles can be parked in the Town Center.

Discussion followed with Chief Deisler on time frames, tags, locations where vehicles can be parked, and right-of-ways.

Manager Boyle said he would get with Ms. Shafer on the matter that she mentioned and would come back with some recommendations.

Deputy Mayor Cannon noted some past on-street parking changes, and that he was interested in looking into situations where cars had not been moved in a long time, as well as parking and right-of-ways.

Continuing, Deputy Mayor Cannon added that he would like such matters looked into including the applicable Ordinance. Deputy Mayor Cannon further added that should other Ordinances need to be reviewed, that the City Commission could help in changing any Ordinances.

Ms. Dolly Ames, 150 3rd Street, Winter Springs, Florida: referenced some information she had provided to the Mayor and City Commission regarding people not walking dogs on leashes and related potential dangers and risks, especially for pets and children.

Commissioner Johnson commented about dog bites, a personal situation, and suggested, "Information needs to go to every citizen in the City and I would encourage anybody in the City who is aware of people who are dog owners that are not being responsible, to call it in right away."

In terms of enforcement, Chief Deisler said that the Police could be called regarding any issues in the City.

Remarks followed on possibly including a flyer in water bills and the associated costs. Manager Boyle asked if the City Commission would consider letting Staff first try an online campaign.

Deputy Mayor Cannon added, "My suggestion is that we do an aggressive public relations social media campaign - and frankly, that we also maybe have Brooke (Procell, Social Media & Marketing Coordinator) come up with a nice little poster and hand them out" Deputy Mayor Cannon thought that Veterinarians in the City could help get this information out, and perhaps we could have some signage near trails and other locations around the City, that dogs must be on leashes.

Mayor Lacey then inquired, "Is there Consensus to take the consolidated ideas from the City Manager and the Deputy Mayor just enunciated? Everyone in agreement with that?" No objections were noted.

Commissioner Hovey added, "We also have a couple of events coming up there that the Police Department and the City can hand out the flyers." Further remarks continued.

Mayor Lacey said to Manager Boyle, "Are you comfortable with the direction you are hearing?" Manager Boyle responded, "I will do it."

Mayor Lacey closed "Public Input".

CONSENT AGENDA

300. Interlocal Agreement Between the Seminole County Sheriff's Office, Seminole County City Municipalities, the Sanford Airport Authority, and Seminole County Public Schools - E911 Protocols.

This Agenda Item was not discussed.

301. Winter Springs Defined Pension Plan Assumed Rate of Return Modification

Commissioner Kendrick complimented Manager Boyle and his Finance team for their great efforts; and then said to Ms. Kelly Balagia, Director, Finance Department, "Thank you so much for everything that you do. The way that you and the Board of Trustees – the way that you handle our Defined Benefit Plan, and our Pension, is the best in the State!"

With further comments, Commissioner Kendrick added, "Job well done and the Board of Trustees are doing an outstanding job under your leadership."

Deputy Mayor Cannon thanked Manager Boyle for his work with the Incremental changes that were being made, and what might be considered going forward.

302. City Manager Contract

This Agenda Item was not discussed.

303. 2019 Chamber ARToberFEST - Festival of the Arts

This Agenda Item was not discussed.

304. Minutes from the Monday, September 23, 2019 City Commission Regular Meeting

This Agenda Item was not discussed.

Regarding the Consent Agenda, Mayor Lacey asked if there was a Motion to Approve.

“MOTION TO APPROVE.” MOTION BY DEPUTY MAYOR CANNON. SECONDED BY COMMISSIONER JOHNSON. DISCUSSION.

VOTE:

**COMMISSIONER HALE: AYE
DEPUTY MAYOR CANNON: AYE
COMMISSIONER JOHNSON: AYE
COMMISSIONER HOVEY: NAY
COMMISSIONER KENDRICK: AYE
MOTION CARRIED.**

PUBLIC HEARINGS AGENDA

400. Not Used

REGULAR AGENDA

500. Utilities Operations, Maintenance, and Management Services Agreement with Veolia Water North America - South, LLC

Ms. Lena Rivera, P.E., D.WRE, Director, Public Works and Utilities Departments introduced this Agenda Item.

Comments followed on the scope of work, the Contract, distribution, related time frames, and TTHMs (Total Trihalomethanes).

Mr. Rob Nicholas, Vice President Development – PPS, Veolia North America, 5071 Endview Pass, Brooksville, Florida: stated, “We talked about – the hydraulic model needs to be updated; it should be focused so that you start where you’re having your most problems. The second thing that we did - I think we’re getting or we have this evening, got the history of complaints, the history of your lab results out in the system, so that those can be put on a map – so, that we know exactly where the problems are occurring in the City. That will then help the Engineers when they run the hydraulic model to look at age of water and what the flow sequencing is.”

Continuing, Mr. Nicholas added, “Part of the transition plan that we’ve worked out together is we’ve already got the water quality expert targeted for a specific date here early in November to come look at the plant.”

Furthermore, Mr. Nicholas said, “It obviously is a problem, and we’re focused on it. We’ve got a plan and we’ve got a schedule.”

Deputy Mayor Cannon thought that the contract should include that Veolia should also staff the Emergency Operations Center (EOC) during storm events to which Mr. Nicholas noted, “I think we changed language to include the EOC (Emergency Operations Center) and we staffed the EOC in the last hurricane event - we’re prepared and ready to do that.”

Manager Boyle said, “I need to amend the Recommendation to include permission by the City Attorney to make some slight modifications to a couple of the paragraphs. It’s all dealing with copyrights of software that he owns. It has nothing to do with the operation of the plant and the data that we own - we didn’t get a chance to make some slight tweaks to it.”

Deputy Mayor Cannon commented that the request was related to intellectual property and stated, "The data that is generated, we will have that data..." Manager Boyle remarked, "...We'll own it..." Deputy Mayor Cannon confirmed, "...We will own it."

"I MAKE THE MOTION MAYOR THAT WE APPROVE THE VEOLIA CONTRACT IN ITEM '500' OF THE AGENDA - WITH LATITUDE TO THE CITY ATTORNEY TO MAKE SLIGHT REVISIONS TO THE LANGUAGE THEREIN WITH RESPECT TO VEOLIA'S INTELLECTUAL PROPERTY." MOTION BY DEPUTY MAYOR CANNON. SECONDED BY COMMISSIONER HALE.

DEPUTY MAYOR CANNON SPOKE OF THE IMPORTANCE OF THIS CONTRACT, REFERENCED PAST WATER ISSUES IN FLINT, MICHIGAN, AND PROVIDED A COPY OF A TASK FORCE REPORT FOR THE RECORD.

MR. NICHOLAS SAID, "IN THE CONTRACT, IT SPECIFIES WHEN YOU ALL VOTED BEFORE, YOU TALKED ABOUT HAVING AN AUDIT, TO GET RECORDS; THAT IS ACTUALLY WORKED INTO THE CONTRACT.

ALL OF US MADE SURE THAT IT WAS INCLUDED IN THERE AND WE'VE SPENT A LOT OF TIME, PARTICULARLY WITH KELLY, ABOUT HOW TO MONITOR US FINANCIALLY, HOW TO LOOK AT THE MAINTENANCE COSTS AND THE MAINTENANCE RECORDS, SO WE'RE VERY COGNIZANT OF THAT AND WE'VE BEEN VERY OPEN WITH LENA (RIVERA) ABOUT HOW WE DO THINGS AND IT'S CERTAINLY IN THE CONTRACT LANGUAGE AS WELL."

DEPUTY MAYOR CANNON POINTED OUT THAT THE DOCUMENT HE WAS PROVIDING FOR THE RECORD WAS THE "MARCH 2016 FLINT WATER ADVISORY TASK FORCE FINAL REPORT."

COMMISSIONER KENDRICK COMMENDED MANAGER BOYLE, AND THEN COMMENTED ON DYNAMICS, THANKED THE VENDOR FOR THEIR PARTNERSHIP, AND SPOKE OF DEPUTY MAYOR CANNON'S RESEARCH."

VOTE:

COMMISSIONER KENDRICK: AYE

COMMISSIONER JOHNSON: AYE

COMMISSIONER HOVEY: AYE

COMMISSIONER HALE: AYE

DEPUTY MAYOR CANNON: AYE

MOTION CARRIED.

Further remarks followed on another community and their water system. Comments continued.

REPORTS

600. City Attorney Anthony A. Garganese, Esquire

Senior City Attorney Eick had no Report.

601. City Manager Shawn Boyle

Manager Boyle recognized Mr. Schmidt on his success with bringing the City's Comprehensive Plan into compliance.

602. City Clerk Andrea Lorenzo-Luaces, MMC

No Report.

603. Seat Two Commissioner/Deputy Mayor Kevin Cannon

Regarding the Comprehensive Plan updates, Mr. Schmidt noted, "Now that the Intergov has been found in compliance, we will continue with the other Elements, but we can start processing Comp[rehensive] Plan Amendments."

Deputy Mayor Cannon commended Mr. Schmidt on being so responsive.

Next, Deputy Mayor Cannon mentioned that he enjoyed planting trees on the Trail and there were more to come.

Concluding his Report, Deputy Mayor Cannon said that he planned to attend a Cybersecurity meeting next week.

604. Seat Three Commissioner Ted Johnson

Commissioner Johnson commended Chief Deisler on his recent Promotions Ceremony and offered his compliments to the honorees. Commissioner Johnson added, "Very well done."

Secondly, Commissioner Johnson mentioned a recent Oviedo-Winter Springs Regional Chamber of Commerce meeting which he thought was very interesting.

Thirdly, Commissioner Johnson spoke of attending a Winter Springs Performing Arts Center occasion, which he enjoyed.

Related to the planting of trees along the Trail, Commissioner Johnson said that he was very pleased to have participated in that initiative.

Next, Commissioner Johnson noted that this Thursday evening at City Hall, a community Workshop for the Gatherings at the Winter Springs Town Center was scheduled.

The Oviedo-Winter Springs Regional Chamber of Commerce's OCTOBERFEST event which would be held this coming weekend was then mentioned, to which Commissioner Johnson said that he was looking forward to attending.

Commissioner Johnson spoke of anticipating going to the Fall Festival hosted by the Oak Forest community, to be held on October the 26th.

Lastly, Commissioner Johnson recognized Ms. Rivera, Mr. Clifton Mullis Public Works Supervisor, Mr. Alberic Jemison (AJ), Stormwater Team Leader, and Mr. Paul Morrison, Utilities Superintendent for their very prompt handling of a resident issue. Commissioner Johnson added, "It is all about service; and your Department is excellent with that and I appreciate it."

605. Seat Four Commissioner TiAnna Hale

Brief comments.

Commissioner Hale also spoke of the Oviedo-Winter Springs Regional Chamber of Commerce's OCTOBERFEST event which would be held this coming weekend.

Next, Commissioner Hale referenced City Government Week and enriching the value of life for our residents.

“I MAKE A MOTION THAT WE EXTEND THE MEETING TO INCLUDE THE REST OF REPORTS AND FOR SECOND PUBLIC INPUT.” MOTION BY DEPUTY MAYOR CANNON. SECONDED BY COMMISSIONER JOHNSON. DISCUSSION.

MOTION CARRIED UNANIMOUSLY.

Continuing with her Report, Commissioner Hale noted that City Government Week begins on October 21st. and added that she would be participating with the Federal Action Strike Team on a trip to Washington D.C. on behalf of the Florida League of Cities, and said that if any residents had any concerns with national issues to contact her.

Next, Commissioner Hale then complimented the Police Department and said to Chief Deisler, “You just have an amazing team, “

Concluding her Report, Commissioner Hale mentioned that an Honor Flight Central Florida trip would be going to Washington D.C. soon, and that an Orientation for the Honor Flight Central Florida organization had been held this past Saturday. Also related to Veterans, Commissioner Hale noted that unfortunately, a couple of WWII Veterans had recently passed away and asked everyone to keep their families in their thoughts.

606. Seat Five Commissioner Geoff Kendrick

Commissioner Kendrick also offered his compliments to Chief Deisler on the recent Promotions Ceremony.

Next, Commissioner Kendrick pointed out that tomorrow was “Coffee with a Cop” day at the Winter Springs’ Starbucks from 9:00 a.m. until 11:00 a.m.

The upcoming Tri-County League of Cities scheduled for October 17th, 2019 was addressed next to which Commissioner Kendrick noted that this event would be held in Oviedo and that local Chamber of Commerce representatives would be speaking to the attendees.

Commissioner Kendrick also referenced the upcoming OCTOBERFEST that was scheduled for the upcoming weekend.

Continuing, Commissioner Kendrick noted that he had been working with Keeth Elementary School to organize a Flag Exchange Ceremony which will be held on the forthcoming Veterans Day, beginning at 8:30 a.m., on the front lawn of their school, and added that everyone was welcome to attend.

Commissioner Kendrick pointed out that Winter Springs High School's Homecoming Parade was scheduled for 6:00 p.m. on Monday, October 28th, 2019 and inquired if the City Commission Regular Meeting for October 28, 2019 could possibly be postponed or changed so that the City Commission as a group could attend and support Winter Springs High School's Homecoming Parade.

Comments ensued that there were no urgent matters that had to be discussed on October 28, 2019, therefore the City Commission could hold off until the next scheduled November 18, 2019 Regular Meeting. Remarks followed with Mr. Caldwell as to whether the City could get a float for the Mayor and City Commission in the Homecoming Parade, albeit at a practical cost.

REGARDING CANCELING THE OCTOBER 28TH, 2019 REGULAR MEETING OF THE CITY COMMISSION, "MOTION TO CANCEL." MOTION BY DEPUTY MAYOR CANNON. SECONDED BY COMMISSIONER HALE. DISCUSSION.

MAYOR LACEY SUMMARIZED, "WE HAVE A MOTION AND A SECOND TO CANCEL THE MEETING ON OCTOBER 28TH."

VOTE:

COMMISSIONER JOHNSON: AYE

COMMISSIONER HOVEY: AYE

COMMISSIONER HALE: AYE

COMMISSIONER KENDRICK: AYE

DEPUTY MAYOR CANNON: AYE

MOTION CARRIED.

Mayor Lacey pointed out that the next Regular Meeting of the City Commission would be held on November 18, 2019.

Commissioner Hovey asked what the City Commission would do if they did not get a float, would they walk in the Parade or something else?

With further comments, Commissioner Kendrick said he would be in touch with the Principal of Winter Springs High School later tonight, and would keep everyone informed.

In terms of whether Staff could get a float within a couple of weeks, Manager Boyle said, "We'll give you an answer by Wednesday."

Regarding the size of a float, remarks followed on how many individuals might be on such a City float, to which Manager Boyle stated, "The probability is greater if it's just the six (6) of you." Commissioner Hovey suggested it should just be for the Elected Officials. Other Commissioners said they liked that suggestion. No objections were voiced.

Next, Commissioner Kendrick said that he had spoken with Florida Representative David Smith who had filed some water related Bills, and Commissioner Kendrick said he planned to do what he could to assist; and also thanked Manager Boyle for his cooperation during this process.

Commissioner Kendrick offered some personal comments, and also complimented Mr. Radka on his work with the Winter Springs Performing Arts Center.

607. Mayor Charles Lacey

No Report.

608. Seat One Commissioner Jean Hovey

Commissioner Hovey noted that on the 26th of October, a Craft Fair would be held at the Winter Springs Senior Center.

Next, Commissioner Hovey spoke to Manager Boyle about the importance of finishing the Cross Seminole Trail project.

In other Reports, Deputy Mayor Cannon referenced the last City Commission Meeting and stated that Seminole County Commissioner Bob Dallari had said they were waiting on a letter from the City to have Seminole County's Engineering and Traffic divisions work with the City; and hoped Manager Boyle could assist with this.

Further remarks.

PUBLIC INPUT

Mayor Lacey opened "Public Input".

Mr. Maurice Kaprow, Post Office Box 195233 Winter Springs, Florida: commended Ms. Rivera on recent repairs her Staff did in the area of Osceola Trail and Howell Creek Drive Road; and mentioned his concern that many bicyclists often do not follow traffic laws, don't stop when they should, and hoped better enforcement could be imposed.

Mrs. Gina Shafer, Winter Springs Village, Winter Springs, Florida: spoke of the speed along State Road 434 being reduced, hoped that the extra greenspace that Dream Finders Homes had offered could be utilized by the City as there was a great need for areas where dogs could be walked, and asked if the City had become a member of an organization which might help with acquiring Grant monies.

Deputy Mayor Cannon thought that going forward, the City needed to make sure we designate specific spaces for walking dogs in future development projects. Mayor Lacey said the City was aware of these issues; Commissioner Kendrick mentioned some planned changes were in the works; and Commissioner Johnson suggested the City could look into some potentially available parcels the City owned which could possibly be cleared out and used for walking dogs.

Mr. James Evans, 217 Almaden Court, Winter Springs, Florida: mentioned there were two (2) Trunk or Treat events, one at Winter Springs High School on October 24th and another at Winter Springs Elementary School on October 25th; and also referenced the upcoming OCTOBERFEST event which he thought was a great occasion.

Mayor Lacey closed "Public Input".

Commissioner Hovey thanked Chief Deisler and his Staff for handling some issues on Cortez related to speeding and illegal parking.

Further comments ensued on upcoming events.

ADJOURNMENT

Mayor Lacey adjourned the Regular Meeting at 8:56 p.m.

RESPECTFULLY SUBMITTED:

ANDREA LORENZO-LUACES, MMC
CITY CLERK

APPROVED:

MAYOR CHARLES LACEY

NOTE: These Minutes were approved at the November 18, 2019 City Commission Regular Meeting.



PUBLIC HEARINGS AGENDA ITEM 400

CITY COMMISSION AGENDA | NOVEMBER 18, 2019 | REGULAR MEETING

TITLE

The Community Development Department requests that the City Commission hold a Public Hearing to consider a Waiver for Northern Oaks, an approved 35-lot single-family residential subdivision.

SUMMARY

Northern Oaks is located just east of the intersection of State Road 434 and State Road 417 (Exhibit 1). On March 13, 2017, Madichristo Land Holdings, LLC came before the Planning and Zoning Board/Local Planning Agency and requested two waivers; 1) Reduce the rear yard setback to 20 ft. in lieu of 25 ft.; and 2) Reduce the side yard setback to 5 ft. in lieu of 6 ft. per Sec. 20-186(2)(3), for the entire subdivision.

The Planning and Zoning Board/Local Planning Agency recommended approval of the waivers on March 1, 2017 and the City Commission approved the waivers on March 13, 2017. The approval of the above waivers allows for additional square footage for the proposed 35 single family lots in Northern Oaks.

As an oversight, the previous applicant, Madichristo Land Holdings, LLC did not request a waiver to increase the lot coverage for the 35 single-family lots, which is necessary as the approved waivers increase the footprint for the proposed 35 single family lots in Northern Oaks. Dream Finders Homes, LLC, the current applicant is requesting a waiver to increase the maximum lot coverage in the R-1 one-family dwelling district to fifty (50) percent in lieu of forty (40) percent per Sec. 20-187 Lot Coverage.

During the initial review by the former City Engineer, the storm water calculations appeared sufficient. However, due to concerns in regards floodplains to the north, the Community Development Department completed a second review with assistance of the new City Engineer CPH Engineers, Inc. (CPH) and completed the review on October 2, 2019. The City Engineer (CPH) reviewed the Final Engineering Plan and storm water calculations retrieved from the St. Johns River Water Management District (SJRWMD) to verify the total impervious area per lot. The City Engineer (CPH) determined that the maximum increase of lot coverage may increase up to fifty (50) percent, not fifty-five (55) percent, per the applicant's original request. The applicant has reduced the request to fifty (50) percent.

The request is in line with emerging development patterns within the City of Winter Springs, for example, in Tuskawilla Crossings the lot coverage within this development varies from forty (40) percent, sixty (60) percent, eighty (80) percent.

General Information:					
Applicant	Dream Finders Homes, LLC (Dream Finders)				
Property Owner(s)	Dream Finders Homes, LLC & HDP Northern Oaks, LLC				
Location	State Road 434 and State Road 417				
Tract Size	35 Single Family Residential Lots on 20.48 Acres				
Parcel ID Numbers	04-21-31-511-0000-0010, 04-21-31-511-0000-0020, 04-21-31-511-0000-0030, 04-21-31-511-0000-0040, 04-21-31-511-0000-0050, 04-21-31-511-0000-0060, 04-21-31-511-0000-0070, 04-21-31-511-0000-0080, 04-21-31-511-0000-0090, 04-21-31-511-0000-0100, 04-21-31-511-0000-0110, 04-21-31-511-0000-0120, 04-21-31-511-0000-0130, 04-21-31-511-0000-0150, 04-21-31-511-0000-0160, 04-21-31-511-0000-0170, 04-21-31-511-0000-0180, 04-21-31-511-0000-0190, 04-21-31-511-0000-0200, 04-21-31-511-0000-0210, 04-21-31-511-0000-0220, 04-21-31-511-0000-0230, 04-21-31-511-0000-0240, 04-21-31-511-0000-0250, 04-21-31-511-0000-0260, 04-21-31-511-0000-0270, 04-21-31-511-0000-0280, 04-21-31-511-0000-0290, 04-21-31-511-0000-0300, 04-21-31-511-0000-0310, 04-21-31-511-0000-0320, 04-21-31-511-0000-0330, 04-21-31-511-0000-0340, 04-21-31-511-0000-0350				
Zoning Designation	R-1 One-Family Dwelling Districts				
FLUM Designation	Low Density Residential				
Adjacent Land Use	<table border="0"> <tr> <td>North: Winter Springs (PUD)</td> <td>South: City of Oviedo</td> </tr> <tr> <td>East: Winter Springs (C-1)</td> <td>West: Seminole County Agriculture (A-1)/ Winter Springs (GID)</td> </tr> </table>	North: Winter Springs (PUD)	South: City of Oviedo	East: Winter Springs (C-1)	West: Seminole County Agriculture (A-1)/ Winter Springs (GID)
North: Winter Springs (PUD)	South: City of Oviedo				
East: Winter Springs (C-1)	West: Seminole County Agriculture (A-1)/ Winter Springs (GID)				
Approved Waivers	<p>1) Reduce the rear yard setback to 20 ft. in lieu of 25 ft.; and</p> <p>2) Reduce the side yard setback to 5 ft. in lieu of 6 ft. per Sec. 20-186(2)(3), for the entire subdivision.</p>				

Development Agreement	Approved
Code Enforcement	Not applicable
City Liens	Not applicable

Waiver Requirement:

Section 20-24. – Waivers.

- (a) Any real property owner may file a waiver application requesting a waiver for their real property from any term and condition of this chapter (except from the list of permitted, conditional and prohibited uses set forth in any zoning district category). If the property owner clearly demonstrates that the applicable term or condition clearly creates an illogical, impossible, impractical, or patently unreasonable result.
- (b) The Planning and Zoning Board shall be required to review all waiver applications and make a written recommendation to the City Commission. Such recommendation shall include the reasons for the Board's recommendation and show the board has considered the applicable waiver criteria set forth in this section.
- (c) Upon receipt of the Planning and Zoning Board's recommendation, the City Commission shall make a final decision on the application. If the City Commission determines that the Planning and Zoning Board has not made a recommendation on an application within a reasonable period of time, the City Commission may, at its discretion, consider an application without the Planning and Zoning Board's recommendation.
- (d) All waiver recommendations and final decisions shall comply with the following criteria:

Waivers Description/Justification (Exhibit 2)

1.	Dream Finders Homes, LLC is requesting a waiver to increase the maximum lot coverage for the R-1 one-family dwelling district up to fifty (50) percent in lieu of forty (40) percent per Sec. 20-187 Lot Coverage. Per Code the maximum lot coverage is 40% and the proposed lot coverage is up to a maximum of 50%. <u>Justification</u> The applicant is seeking relief to accommodate the increased footprint for the previously approved waivers of the proposed 35 single-family lots in Northern Oaks.
----	--

Any real property owner may file a waiver application requesting a waiver for their real property from any term and condition of this chapter (except from the list of permitted, conditional and prohibited uses set forth in any zoning district category) if the property owner clearly demonstrates that the applicable term or condition clearly creates an illogical, impossible, impractical, or patently unreasonable result.

Upon receipt of the Planning and Zoning Board’s recommendation, the City Commission shall make a final decision on the application. If the City Commission determines that the Planning and Zoning Board has not made a recommendation on an application within a reasonable period of time, the City Commission may, at its discretion, consider an application without the Planning and Zoning Board's recommendation.

Waiver criteria set forth in Subsection 20-34(d) are as follows:

1.	The applicant clearly demonstrates that the applicable term or condition clearly creates an illogical, impossible, impractical, or patently unreasonable result related to the proposed property and development.
2.	The proposed development plan is in substantial compliance with this chapter and in compliance with the comprehensive plan.
3.	The proposed development plan will significantly enhance the real property.
4.	The proposed development plan serves the public health, safety, and welfare.
5.	The waiver will not diminish property values in or alter the essential character of the surrounding neighborhood.

6.	The waiver granted is the minimum waiver that will eliminate or reduce the illogical, impossible, impractical, or patently unreasonable result caused by the applicable term or condition under this chapter.
7.	The proposed development plan is compatible and harmonious with the surrounding neighborhood.
8.	Whether the applicant has agreed to execute a binding development agreement required by city to incorporate the terms and conditions of approval deemed necessary by the city commission including, but not limited to, any mitigative techniques and plans required by City Code.

In evaluation of the proposed waiver request, it appears that the request satisfies the eight (8) specific criteria required for Waivers in the City Code of Ordinances.

Applicable Law, Public Policy, and Events:

Home Rule Powers

Winter Springs Code of Ordinances

City of Winter Springs Comprehensive Plan

Procedural History:	
February 22, 2016	City Commission approval of the Northern Oaks Annexation, Large-Scale Future Land Use Amendment, and Rezoning to Low Density Residential and R-1 (One-family dwelling)
January 8, 2018	City Commission (Northern Oaks Preliminary Engineering Plans) Approval
March 1, 2017	Planning & Zoning Board/Local Planning Agency Recommendation (Northern Oaks Final Engineering Plans and Waiver Requests) Approval
March 13, 2017	City Commission (Northern Oaks Final Engineering Plans and Waiver Requests) Approval
November 2017	Site work construction commenced and is currently in progress
April 9, 2018	City Commission Aesthetic Review Plans Approval
July 12, 2019	Administrative Waiver was approved for four lots to increase the lot coverage to from 40% to 44% (Lots 5, 6, 7, and 20)

October 2, 2019	Planning & Zoning Board/Local Planning Agency Recommendation (Northern Oaks Waiver Request) Approval
-----------------	--

Fiscal Impact:

Development of the subject property is anticipated to provide an increase to the City’s taxable value. The potential tax revenue of the proposed project is as follows:

- Fee Simple Single Family Residential Units - 35 units
- Units - 35 assessed at \$200,000 = \$7,000,000 assessed tax value
 - $\$10,800,000/1000 = 7,000$
 - $\$7,000.00 \times (2.4300) = \$17,010$
 - $\$17,010$ (less the 4% statutory discount) = \$16,329.60 tax revenue

Communication Efforts:

The Meeting Agenda and this Agenda Item have been forwarded to the Planning and Zoning Board members and are available on the City’s Website, LaserFiche, and the City’s Server. The Agenda has been forwarded to the Mayor and City Commission; City Manager; and City Attorney/Staff. Additionally, the Meeting Agenda has been sent to media/press representatives, all Homeowner’s Associations on file with the City, all individuals who have requested Agenda information, Department Directors; and also posted outside City Hall; posted inside City Hall with additional copies available for the general public.

RECOMMEDATION

Staff recommends that the City Commission approve the requested Waiver to increase the maximum lot coverage for the R-1 one-family dwelling district up to fifty (50) percent in lieu of forty (40) percent for the Northern Oaks Subdivision.

Attachments:

1. *Exhibit 1 – Vicinity Map*
2. *Exhibit 2 – Waiver Application*
3. *Exhibit 3 – Final Engineering Plan*
4. *Exhibit 4 – Commission Agenda, February 11, 2019*
5. *Exhibit 5 – Letter from City Engineer (CPH), October 2, 2019*

Vicinity Map

Northern Oaks

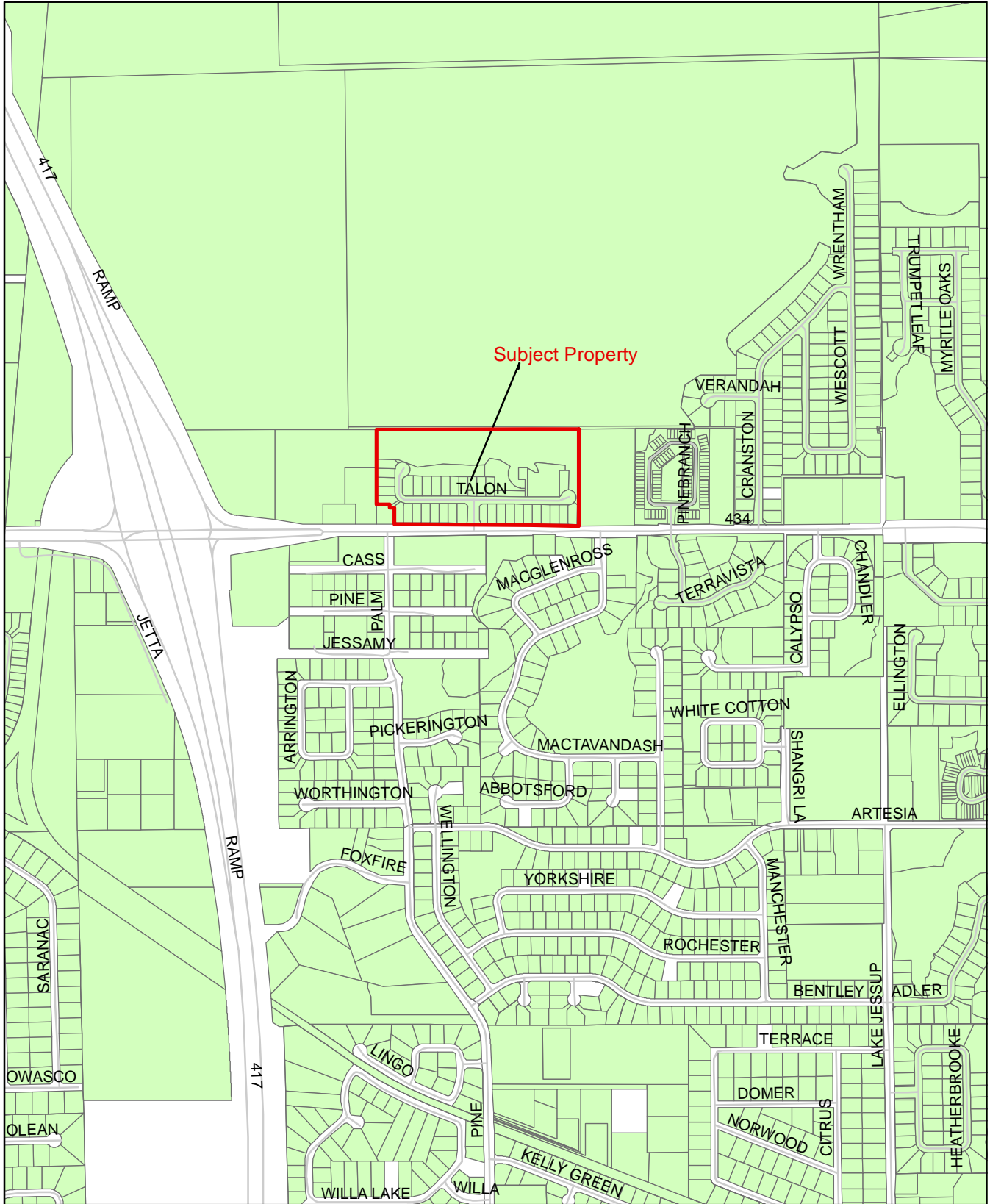

Legend

- Streets
- Parcels

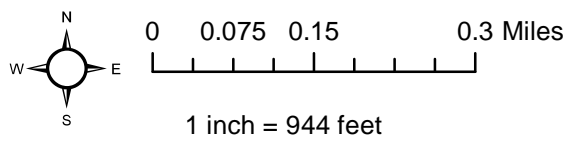



**CITY OF WINTER SPRINGS
COMMUNITY DEVELOPMENT DEPARTMENT**

1126 East State Road 434
Winter Springs, Florida 32708
customerservice@winterspringsfl.org

Application – Waiver

The Community Development Director reserves the right to determine whether this application is complete and accurate. An incomplete application will not be processed and will be returned to the applicant. The application shall be reviewed per [Chapter 20 – Zoning Sec. 20-34](#). The processing time may take up to ten (10) business days.

Applicants are responsible for posting notice (provided by the city) on the site at least seven (7) days prior to the Planning & Zoning Board (PZB) meeting at which the matter will be considered. Said notice shall not be posted within the City right-of-way.

All applicants shall be afforded minimal due process as required by law, including the right to receive notice, be heard, present evidence, cross-examine witnesses, and be represented by a duly authorized representative. Applicants are further advised that a Waiver is quasi-judicial in nature.

Therefore, APPLICANT ACKNOWLEDGES and AGREES, by signing below, that he or she:

- May be sworn-in as a witness in order to provide testimony to the City Commission;
- Shall be subject to cross-examination by party intervenors (if requested); and
- Shall be required to qualify expert witnesses, as appropriate.

Applicants are encouraged to familiarize themselves with [Chapter 2 – Administration Sec. 2-30](#) of the Winter Springs City Code relating to Quasi-Judicial Rules and Procedures of the City Commission. All Waiver recommendations shall be based from the required information/documentation provided, the Winter Springs Code of Ordinances, and the Winter Springs Comprehensive Plan (to the extent applicable).

The City Commission (CC) shall render all final decisions regarding Waivers and may impose reasonable conditions on any approved Waiver to the extent deemed necessary and relevant to ensure compliance with applicable criteria and other applicable provisions of the Winter Springs Code of Ordinances and the Winter Springs Comprehensive Plan. All formal decisions shall be based on competent substantial evidence and the applicable criteria as set forth in Chapter 20, Zoning. Applicants are advised that if, they decide to appeal any decisions made at the meetings or hearings with respect to any matter considered at the meetings or hearings, they will need a record of the proceedings and, for such purposes, they will need to insure that a verbatim record of the proceedings is made, at their cost, which includes the testimony and evidence upon which the appeal is to be based, per [Florida Statute 286.0105](#).

A Waiver which may be granted by the City Commission shall expire two (2) years after the effective date of such approval by the City Commission, unless a building permit based upon and incorporating the Waiver, is issued by the City within said time period. Upon written request of the property owner, the City Commission may extend the expiration date, without public hearing, an additional six (6) months, provided the property owner demonstrates good cause for the extension. In addition, if the aforementioned building permit is timely issued, and the building permit subsequently expires and the subject development project is abandoned or discontinued for a period of six months, the Waiver shall be deemed expired and null and void, per [Chapter 20 – Sec.20-36](#).



**CITY OF WINTER SPRINGS
COMMUNITY DEVELOPMENT DEPARTMENT**

1126 East State Road 434
Winter Springs, Florida 32708

customerservice@winterspringsfl.org

Application – Waiver

2019-0000013

REQUIRED INFORMATION:

Applicant(s): Dream Finders Homes, LLC Date: 8/12/19

Mailing address: 8529 Southpark Circle, Suite 130, Orlando, FL 32819

Email: dan.edwards@dreamfindershomes.com

Phone Number: 813-484-7665

Property Owner(s): Dream Finders Homes, LLC & HDP Northern Oaks, LLC

Mailing Address: 8529 Southpark Circle, Suite 130, Orlando, FL 32819

Email: dan.edwards@dreamfindershomes.com and batey.mcgraw@dreamfindershomes.com

Phone Number: 813-484-7665

Project Name: Northern Oaks

Property Address: See list attached

Parcel ID(s): See list attached

Parcel Size: 7,500 - 7,800 square foot lots

Existing Use: LDR - Low Density Residential

Future Land Use: LDR - Low Density Residential

Zoning District: R-1

Waiver that is being requested? Change allowable lot coverage of primary building to 55%

Demonstrate that the applicable term or condition clearly creates an illogical, impossible, impractical, or patently unreasonable result related to the proposed property and development?

Dream Finders Homes request to amend maximum lot coverage requirements from 40% to 55% for remaining lots in the Northern Oaks Community. During the Preliminary Subdivision Plan and Engineering Plan approval process of this community, two waivers were granted by the City of Commission reducing the underlying side-yard and rear yard setbacks.

The approval of these waivers increased the buildable pad of these lots with the intent of allowing larger home footprints in Northern Oaks. However, an oversight was made by not also requesting a waiver for the Lot Coverage maximum matching the approved buildable pad size with the waivers that were approved as the Lot Coverage Maximum under R-1 is 55%

Demonstrate that the proposed development plan is in substantial compliance with Chapter 20 of the City's Code of Ordinances and in compliance with the Comprehensive Plan?

The project is in compliance with the Northern Oaks plans approved as Item 401 of the March 13, 2017 City Commissioners Meeting (See attached).



**CITY OF WINTER SPRINGS
COMMUNITY DEVELOPMENT DEPARTMENT**

1126 East State Road 434
Winter Springs, Florida 32708
customerservice@winterspringsfl.org

Application – Waiver

Will the proposed development plan significantly enhance the real property?

Yes _____

Will the proposed development plan serve the public health, safety, and welfare of the City of Winter Springs?

Yes _____

Will the waiver diminish property values in or alter the essential character of the surrounding neighborhood?

No _____

Is the waiver request the minimum waiver that will eliminate or reduce the illogical, impossible, impractical, or patently unreasonable result caused by the applicable term or condition under [Chapter 20 – Zoning](#)?

Yes _____

Is the proposed development plan compatible and harmonious with the surrounding neighborhood?

Yes _____

Has the applicant agreed to a binding development agreement required by city to incorporate the terms and conditions of approval deemed necessary by the City Commission including, but not limited to, any mitigative techniques and plans required by city code? Yes _____ No ^x_____

Applicant willing to agree if necessary.



**CITY OF WINTER SPRINGS
COMMUNITY DEVELOPMENT DEPARTMENT**

1126 East State Road 434
Winter Springs, Florida 32708
customerservice@winterspringsfl.org

Application – Waiver

List all witnesses that the applicant intends to present to the City Commission to provide testimony:

Dan Edwards

Describe with specificity any evidence which the applicant intends to present to the City Commission, including oral factual testimony, maps, photographs, records or reports and/or expert testimony:

See attached.

Attach all documentary evidence which the applicant intends to present to the city commission to the back of this application.

The Applicant has a continuing duty to update the list of witnesses, description of evidence, and documentary evidence throughout the application process. Additional witnesses or evidence will not be admitted at the city commission hearing if not submitted at least seven (7) days prior to such hearing.

REQUIRED DOCUMENTATION (PDF):

- X A complete Application and Fee (\$500.00*)
- X A general description of the relief sought under this division
- X A brief explanation, with applicable supporting competent substantial evidence and documents, as to why the application satisfies the relevant criteria set forth in this division
- X A Legal Description accompanied by a certified survey or the portion of the map maintained by the Seminole County Property Appraiser reflecting the boundaries of the subject property (To scale).
- X An Excel mailing list with the names and addresses of each property owner within 500 ft. of each property line, along with the HOA Associations within 1/2 mile of each property line.
- NA For all new commercial development and new residential subdivisions of ten (10) or more lots or existing commercial buildings being altered by 50 percent or greater of the original floor plan or seating capacity and requiring a modified site plan, or development agreements process under section 20-28.1 of the City Code, or as otherwise deemed applicable by the city to relevantly and competently examine an application for compliance with the city code and the affect and impact the proposed use will have on neighborhood and surrounding properties, applicants shall be required to submit with the following additional information referenced in [Chapter 20 – Zoning Sec.20.29 Applications \(7\) – \(11\)](#).

* Fees are as shown above plus actual costs incurred for advertising or notification, and for reimbursement for technical and/or professional services which may be required in connection with the review, inspection or approval of any development (based on accounting submitted by the city’s consultant) , payable prior to approval of the pertinent stage of development.



CITY OF WINTER SPRINGS
COMMUNITY DEVELOPMENT DEPARTMENT

1126 East State Road 434
Winter Springs, Florida 32708
customerservice@winterspringsfl.org

Application – Waiver

CITY LIMITED RIGHT OF ENTRY: By submitting this Application you hereby grant temporary right of entry for City Officials to enter upon the subject property for purposes of evaluating this Application.

APPLICANT'S AUTHORIZATION: I desire to make Application for a Waiver for the aforementioned project and have read and agree to the terms contained herein. In addition, if the Applicant is a corporate entity, the undersigned hereby represents and warrants that he/she is authorized to act on behalf of, and bind, the corporate entity.

Applicant Name (Print): Don Edwards
Applicant Signature: [Signature] Date: 8-12-19
Business Name: Dream Finders Homes, LLC
Address: 8529 Southpark Circle Parcel ID: See attached list
Property Owner's Name (Print): Betsy C. McGraw, Vice President
Property Owner Signature: [Signature] Date 8/12/19
STATE OF Florida COUNTY OF Orange

The foregoing instrument was acknowledged before me this 12th day of August, 2019, by Don Edwards who is personally known to me or who has produced Florida Drivers License as identification and who did/did not take an oath.

Date: August 12th, 2019 (seal):
Notary Public Signature: Jarah H.
My Commission expires: 2/3/2022

Note: The Property Owner shall sign and have their signature notarized below if the Applicant is not the owner of the subject property.

Property Owner's Name (Print): HDP Northwood Oaks, LLC
Property Owner Signature: [Signature] Date 8/12/19
STATE OF Florida COUNTY OF Duval

The foregoing instrument was acknowledged before me this 12th day of August, 2019, by Betsy C. McGraw, VP who is personally known to me or who has produced [Signature] as identification and who did/did not take an oath.

Date: August 12, 2019 (seal):
Notary Public Signature: [Signature]
My Commission expires: June 3, 2021

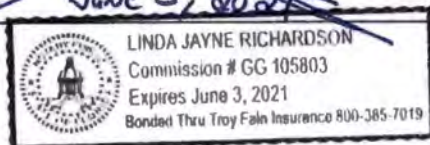

GENERAL NOTES

- UNLESS OTHERWISE SPECIFIED, ALL WORK SHALL BE PERFORMED CONSISTENT WITH THE FOLLOWING SPECIFICATIONS:
 - CITY OF WINTER SPRINGS, FLORIDA
 - ST. JOHNS RIVER WATER MANAGEMENT DISTRICT
 - FLORIDA DEPARTMENT OF ENVIRONMENTAL PROTECTION
 - NATIONAL POLLUTANT DISCHARGE ELIMINATION SYSTEM
- THE GEOTECHNICAL REPORT DONE BY G.E.O. ENGINEERING & SCIENCES, INC., DATED MARCH 24, 2016, SHALL BE REVIEWED BY THE CONTRACTOR, AND THE CONTRACTOR SHALL FAMILIARIZE HIMSELF WITH THE SITE, INCLUDING ALL SURFACE AND SUBSURFACE CONDITIONS, THE WORK REQUIRED, AND ALL OTHER CONDITIONS THAT MAY AFFECT THE SUCCESSFUL COMPLETION OF THE JOB PRIOR TO COMMENCEMENT OF WORK.
- THE CONTRACTOR SHALL GIVE ALL NOTICES AND COMPLY WITH ALL LAWS, ORDINANCES, RULES, REGULATIONS AND PERMIT CONDITIONS BEARING ON THE CONDUCT OF THE WORK, AS DRAWN AND SPECIFIED, IF THE CONTRACTOR OBSERVES THAT THE DRAWINGS AND SPECIFICATIONS ARE AT VARIANCE THEREWITH, HE SHALL PROMPTLY NOTIFY THE ENGINEER, IN WRITING, AND ANY NECESSARY CHANGES SHALL BE ADJUSTED, AS PROVIDED IN THE AGREEMENT FOR CHANGES IN THE WORK.
- THE CONTRACTOR SHALL BE RESPONSIBLE TO THE OWNER AND THE ENGINEER FOR THE ACTS AND OMISSIONS OF CONTRACTOR'S EMPLOYEES AND ALL HIS SUBCONTRACTORS AND THEIR AGENTS AND EMPLOYEES AND OTHER PERSONS PERFORMING ANY OF THE WORK UNDER A CONTRACT WITH THE CONTRACTOR.
- THE CONTRACTOR SHALL BE RESPONSIBLE FOR MAKING ALL NECESSARY ARRANGEMENTS WITH GOVERNMENTAL DEPARTMENTS, PUBLIC UTILITIES, PUBLIC CARRIERS, SERVICE COMPANIES, AND CORPORATIONS OWNING OR CONTROLLING ROADS, RAILWAYS, WATER, SEWER, GAS, ELECTRICAL, TELEPHONE, AND TELEGRAPH FACILITIES SUCH AS PAVEMENTS, TRACKS, PIPING, WIRES, CABLES, CONDUITS, POLES, GUYS, OR OTHER SIMILAR FACILITIES, INCLUDING INCIDENTAL STRUCTURES CONNECTED THEREWITH THAT ARE ENCOUNTERED IN THE WORK IN ORDER THAT SUCH ITEMS MAY BE PROPERLY SUPPORTED, PROTECTED OR LOCATED.
- UNLESS OTHERWISE SPECIFIED IN THE GENERAL CONDITIONS, ALL CONSTRUCTION IS TO BE GOVERNED BY THE PLANS, APPLICABLE PERMITS, AND SPECIFICATIONS HEREIN, AND ALL APPLICABLE FEDERAL, STATE AND LOCAL BUILDING AND SAFETY CODES, LAWS AND ORDINANCES.
- PRIOR TO PERFORMING ANY WORK WITHIN ANY PUBLIC RIGHT-OF-WAY, CONTRACTOR SHALL OBTAIN AUTHORIZATION AND PERMIT FROM JURISDICTION RESPONSIBLE FOR SUCH RIGHT-OF-WAY. IN ADDITION, CONTRACTOR SHALL OBTAIN GAS I.D. NUMBER FROM LOCAL GAS COMPANY AND NOTIFY SUNSHINE STATE ONE-CALL UTILITY NOTIFICATION CENTER AT 1-800-432-4770 AT LEAST 48 HOURS PRIOR TO START OF WORK.
- PRIOR TO PERFORMING ANY WORK WITHIN ANY PUBLIC RIGHT-OF-WAY, CONTRACTOR SHALL DEVELOP AND IMPLEMENT A TRAFFIC CONTROL PLAN CONSISTENT WITH THE "MANUAL ON UNIFORM TRAFFIC CONTROL DEVICES" PUBLISHED BY THE U.S. DEPARTMENT OF TRANSPORTATION, FEDERAL HIGHWAY ADMINISTRATION, AND SUBMIT TO THE CITY ENGINEER FOR APPROVAL.
- IN THE EVENT THE CONTRACTOR DISCOVERS ANY ERRORS OR OMISSIONS IN THE PLANS HE SHALL IMMEDIATELY NOTIFY THE ENGINEER AND/OR OWNER OR OWNER'S AGENT.
- CONTRACTOR SHALL PRESERVE AND PROTECT ALL PERMANENT REFERENCE MONUMENTS, PERMANENT CONTROL POINTS, PERMANENT BENCH MARKS AND PROPERTY CORNERS. IN THE EVENT THE MONUMENTS, POINTS OR MARKERS ARE DISTURBED THE CONTRACTOR SHALL EMPLOY A FLORIDA REGISTERED LAND SURVEYOR TO RESET OR REPLACE THEM.
- THE OWNER, OWNER'S AGENT AND INSPECTORS OF APPLICABLE GOVERNMENT JURISDICTIONS, SHALL AT ALL TIMES HAVE ACCESS TO THE WORK WHEREVER AND WHENEVER IT IS IN PREPARATION OR PROGRESS, AND THE CONTRACTOR SHALL PROVIDE PROPER FACILITIES FOR SUCH ACCESS AND FOR THE INSPECTION.
- IT IS THE CONTRACTOR'S RESPONSIBILITY TO TAKE ALL REASONABLE AND PRUDENT PRECAUTIONS TO INSURE THAT ALL COMPLETED WORK, MATERIALS AND EQUIPMENT STORED ON SITE ARE SAFE AND SECURED FROM UNAUTHORIZED ACCESS, USE, THEFT, OR VANDALISM. SUCH PRECAUTIONS MAY INCLUDE INSTALLATION OF SIGNS, FENCES, OR POSTING OF SECURITY GUARDS.
- CONTRACTOR SHALL, AT ALL TIMES, UTILIZE ALL NORMALLY ACCEPTED AND REASONABLY EXPECTED SAFETY PRACTICES AND COMPLY WITH ALL FEDERAL, STATE AND LOCAL REGULATIONS, ORDINANCES AND GUIDELINES PERTAINING TO SAFE UTILIZATION OF EQUIPMENT OR MATERIALS AS PUBLISHED BY THEIR MANUFACTURERS.
- PRIOR TO INITIATING ANY EXCAVATION (INCLUDING BUT NOT LIMITED TO TUNNELS, DITCHES, STORM WATER PONDS, CANALS, ARTIFICIAL LAKES) CONTRACTOR SHALL INSTALL FENCES AND/OR TAKE ALL OTHER REASONABLE AND PRUDENT STEPS TO INSURE THAT ACCESS TO EXCAVATION BY UNAUTHORIZED PERSONNEL IS PREVENTED.
- CONTRACTOR SHALL COMPLY IN EVERY RESPECT WITH THE PROVISIONS OF THE FLORIDA STATE TRAFFIC SAFETY ACT.
- THE CONTRACTOR SHALL TAKE ALL REASONABLE PRECAUTIONS FOR THE SAFETY OF, AND SHALL PROVIDE ALL REASONABLE PROTECTION TO PREVENT DAMAGE, INJURY OR LOSS TO:
 - ALL EMPLOYEES ON THE WORK AND ALL OTHER PERSONS WHO MAY BE AFFECTED THEREBY;
 - ALL THE WORK AND ALL MATERIALS AND EQUIPMENT TO BE INCORPORATED THEREIN, WHETHER IN STORAGE ON OR OFF THE SITE, UNDER THE CARE, CUSTODY OR CONTROL OF THE CONTRACTOR OR ANY OF ITS SUBCONTRACTORS;
 - OTHER PROPERTY AT THE SITE OR ADJACENT THERETO, INCLUDING TREES, SHRUBS, LAWN, WALKS, PAVEMENTS, ROADWAY, STRUCTURES AND UTILITIES NOT DESIGNATED FOR DEMOLITION IN THE COURSE OF CONSTRUCTION.
- THE CONTRACTOR SHALL COMPLY WITH ALL APPLICABLE SAFETY CODES AND WITH ALL APPLICABLE LAWS, ORDINANCES, RULES, REGULATIONS AND LAWFUL ORDERS OF ANY PUBLIC, QUASI PUBLIC OR OTHER AUTHORITY HAVING JURISDICTION FOR THE SAFETY OF PERSONS OR PROPERTY OR FOR THEIR PROTECTION AGAINST DAMAGE, INJURY OR LOSS, OR DESIGNED TO PROTECT THE ENVIRONMENT. THE CONTRACTOR SHALL ERECT AND MAINTAIN, AS REQUIRED BY EXISTING CONDITIONS AND PROGRESS OF THE WORK, ALL REASONABLE SAFEGUARDS FOR SAFETY AND PROTECTION, INCLUDING POSTING DANGEROUS SIGNS AND OTHER WARNINGS AGAINST HAZARDS, PROMULGATED SAFETY REGULATIONS AND NOTIFYING OWNERS AND USERS OF ADJACENT UTILITIES OF THE EXISTENCE OF HAZARDS AND OF THE SAFETY REGULATIONS.
- ALL DAMAGE OR LOSS TO ANY PROPERTY CAUSED IN WHOLE OR IN PART BY THE CONTRACTOR, A SUBCONTRACTOR, OR BY ANYONE FOR WHOSE ACTS ANY OF THEM MAY BE LIABLE, SHALL BE REMEDIED BY THE CONTRACTOR, EXCEPT DAMAGE OR LOSS PROPERLY ATTRIBUTABLE SOLELY TO THE ACTS OR OMISSIONS OF THE OWNER, OR THE ENGINEER OR ANYONE EMPLOYED BY THEM, OR FOR WHOSE ACTS ANY OF THEM MAY BE LIABLE, AND NOT PROPERLY ATTRIBUTABLE IN WHOLE OR IN PART, TO THE FAULT OR NEGLIGENCE OF THE CONTRACTOR.
- THOSE PARTS OF WORK IN PLACE WHICH ARE SUBJECT TO DAMAGE BECAUSE OF OPERATIONS BEING CARRIED ON ADJACENT THERETO SHALL BE COVERED, BOARDED UP OR SUBSTANTIALLY ENCLOSED WITH ADEQUATE PROTECTION BY THE CONTRACTOR AT CONTRACTOR'S EXPENSE.
- UNTIL FINAL ACCEPTANCE OF THE WORK BY OWNER, THE CONTRACTOR SHALL HAVE THE CHARGE AND CARE OF AND SHALL BEAR THE RISK OF INJURY OR DAMAGE, LOSS OR EXPENSE TO ANY PART THEREOF, OR TO ANY MATERIALS STORED ON SITE, BY THE ACTION OF THE ELEMENTS OR FROM ANY OTHER CAUSE WHETHER ARISING FROM THE EXECUTION OR NON-EXECUTION OF THE WORK, THE CONTRACTOR SHALL REBUILD, REPAIR, RESTORE AND MAKE GOOD ALL INJURIES OR DAMAGE TO ANY PORTION OF THE WORK OCCASIONED BY ANY OF THE ABOVE CAUSES BEFORE FINAL ACCEPTANCE AND SHALL BEAR THE EXPENSE THEREOF.
- ADEQUATE TRAFFIC CONTROL, BARRICADES AND FLAGMAN SERVICES SHALL BE FURNISHED AND MAINTAINED BY THE CONTRACTOR AT ALL POINTS WHERE CONVEYING EQUIPMENT ENGAGED ON THE WORK REGULARLY ENTERS ONTO OR CROSSES TRAFFIC-CARRYING ROADS.
- THE CONTRACTOR SHALL COMPLY IN EVERY RESPECT WITH THE FEDERAL OCCUPATIONAL HEALTH AND SAFETY ACT OF 1970 AND ALL REGULATIONS NOW OR HEREINAFTER IN EFFECT UNDER SAID ACT, AND THE CONTRACTOR FURTHER AGREES TO COMPLY WITH ANY AND ALL APPLICABLE STATE LAWS AND REGULATIONS PERTAINING TO JOB SAFETY AND HEALTH.
- CONTRACTOR AND ITS SUBCONTRACTORS SHALL USE, HANDLE, TRANSPORT, AND DISPOSE OF ALL MATERIALS (HAZARDOUS OR OTHERWISE) IN COMPLIANCE WITH ALL PRESENT FEDERAL, STATE AND LOCAL ENVIRONMENTAL, HEALTH OR SAFETY LAW, INCLUDING, BUT NOT LIMITED TO, ALL SUCH STATUTES, REGULATIONS, RULES, ORDINANCES, CODES, AND RULES OF COMMON LAW.

- CONTRACTOR FURTHER AGREES THAT CONTRACTOR AND ITS SUBCONTRACTORS SHALL NOT CAUSE THE DISCHARGE, RELEASE OR DISPOSAL OF ANY HAZARDOUS MATERIAL CREATED BY ITS WORK ON OR ABOUT THE JOB SITE. IN THE EVENT OF ANY SPILL, LEAK OR ANY OTHER REPORTABLE OCCURRENCE, CONTRACTOR SHALL NOTIFY THE APPROPRIATE GOVERNMENTAL AGENCY AND SHALL TAKE SUCH ACTION AS MAY BE NECESSARY TO MINIMIZE THE DELETERIOUS EFFECT OF SUCH SPILL ON PERSONS OR PROPERTY.
- THE CONTRACTOR SHALL PROTECT AND KEEP OWNER (INCLUDING THEIR AGENTS AND EMPLOYEES) FREE AND HARMLESS FROM ANY AND ALL LIABILITY, PUBLIC OR PRIVATE, PENALTIES, CONTRACTUAL OR OTHERWISE, LOSSES, DAMAGES, COSTS, ATTORNEY'S FEES, EXPENSES, CAUSES OF ACTION, CLAIMS OR JUDGMENTS RESULTING FROM THE FAILURE OF CONTRACTOR, AND THE CONTRACTOR SHALL FAMILIARIZE HIMSELF WITH THE SITE, INCLUDING ALL PROMULGATED THEREUNDER OR OF ANY STATE LAWS OR REGULATIONS PERTAINING TO JOB SAFETY AND HEALTH ARISING OUT OF OR IN ANY WAY CONNECTED WITH THE PERFORMANCE OF WORK OR WORK TO BE PERFORMED UNDER THIS CONTRACT, AND CONTRACTOR SHALL INDEMNIFY OWNER FROM ANY SUCH CLAIMS, PENALTIES, SUITS OR ACTIONS, PUBLIC OR PRIVATE, ADMINISTRATIVE OR JUDICIAL, INCLUDING ATTORNEY'S FEES PAID OR INCURRED BY OR ON BEHALF OF OWNER, JOINTLY OR SEVERALLY, AND/OR THEIR AGENTS AND EMPLOYEES, THE CONTRACTOR TO BE PERFORMED UNDER THIS CONTRACT, OWNER MAY IMMEDIATELY TAKE WHATEVER ACTION IS DEEMED NECESSARY BY OWNER TO REMEDY THE CLAIMED VIOLATION, AND ALL COSTS OR EXPENSES PAID OR INCURRED BY OWNER IN TAKING SUCH ACTION SHALL BE BORNE BY CONTRACTOR, AND CONTRACTOR AGREES TO PROTECT, HOLD HARMLESS AND INDEMNIFY OWNER AGAINST ANY AND ALL SUCH COSTS OR EXPENSES.
- CONTRACTOR AND ITS SUBCONTRACTORS SHALL UPON COMPLETION OF PERFORMANCE OF ALL DUTIES UNDER THIS CONTRACT, REMOVE ALL SUPPLIES, MATERIALS, AND WASTE CONTAINING AND HAZARDOUS MATERIAL FROM THE JOB SITE. CONTRACTOR SHALL BEAR FULL FINANCIAL RESPONSIBILITY, AS BETWEEN THE PARTIES OF THIS CONTRACT, FOR THE COMPLIANCE OF CONTRACTOR AND ITS SUBCONTRACTORS WITH THE PROVISIONS OF THIS CONTRACT.
- CONTRACTOR AGREES TO INDEMNIFY, DEFEND, PROTECT AND HOLD THE OWNER HARMLESS FROM AND AGAINST ANY CLAIMS INCLUDING, WITHOUT LIMITATION, ACTUAL, ATTORNEY'S FEES AND ANY COSTS OF INVESTIGATION, SOILS TESTING, GOVERNMENTAL APPROVALS, REMEDIATION AND CLEANUP ARISING OUT OF OR IN ANY WAY CONNECTED WITH THE FAILURE OF CONTRACTOR OR ITS SUBCONTRACTORS, OR THEIR AGENTS, EMPLOYEES, OFFICERS, OR REPRESENTATIVES, TO COMPLY WITH THE TERMS OF THESE CONSTRUCTION DOCUMENTS.
- SHOULD CONTRACTOR OR ITS SUBCONTRACTORS DISCHARGE, RELEASE OR DISPOSE OF ANY HAZARDOUS MATERIAL ON OR ABOUT THE JOB SITE IN VIOLATION OF THESE CONSTRUCTION DOCUMENTS, CONTRACTOR SHALL IMMEDIATELY SO INFORM OWNER & ENGINEER IN WRITING. IN THE EVENT OF ANY SPILL, RELEASE OR ANY OTHER REPORTABLE OCCURRENCE, CONTRACTOR SHALL NOTIFY THE APPROPRIATE GOVERNMENTAL AGENCY, OWNER & ENGINEER AND SHALL TAKE SUCH ACTION AS MAY BE NECESSARY TO MINIMIZE THE DELETERIOUS EFFECT OF SUCH SPILL ON PERSONS OR PROPERTY.
- IN THE EVENT CONTRACTOR OR ITS SUBCONTRACTORS ENCOUNTER ON THE PREMISES ANY PIPELINE, UNDERGROUND STORAGE TANK OR OTHER CONTAINER, OF ANY KIND, THAT MAY CONTAIN A HAZARDOUS MATERIAL, OR ENCOUNTER MATERIAL REASONABLY BELIEVED TO BE A HAZARDOUS MATERIAL, CONTRACTOR SHALL IMMEDIATELY STOP WORK IN THE AREA AFFECTED AND REPORT THE CONDITION TO OWNER AND/OR ENGINEER IN WRITING.
- "HAZARDOUS MATERIAL" MEANS ANY SUBSTANCE: (A) THE PRESENCE OF WHICH REQUIRES INVESTIGATION OR REMEDIATION UNDER ANY PRESENT FEDERAL, STATE OR LOCAL STATUTE, REGULATION, ORDINANCE, RULE, CODE, ORDER, ACTION, POLICY OR COMMON LAW, OR (B) WHICH IS OR BECOMES DEFINED AS A "HAZARDOUS WASTE," "HAZARDOUS SUBSTANCE," POLLUTANT OR CONTAMINANT UNDER ANY PRESENT FEDERAL, STATE OR LOCAL STATUTE, REGULATION, RULE OR ORDINANCE OR AMENDMENTS THERETO INCLUDING, WITHOUT LIMITATION, THE COMPREHENSIVE ENVIRONMENTAL RESPONSE COMPENSATION AND LIABILITY ACT (42 U.S.C. SECTIONS 9601 ET SEQ.) AND/OR THE RESOURCE CONSERVATION AND RECOVERY ACT (42 U.S.C. SECTIONS 6901 ET SEQ.), OR (C) WHICH IS TOXIC, EXPLOSIVE, CORROSIVE, FLAMMABLE, INFECTIOUS, RADIOACTIVE, CARCINOGENIC, MUTAGENIC, OR OTHERWISE HAZARDOUS AND IS REGULATED BY ANY GOVERNMENTAL AUTHORITY, AGENCY, DEPARTMENT, COMMISSION, BOARD, AGENCY OR INSTRUMENTALITY OF THE UNITED STATES, THE STATE IN WHICH THE PREMISES ARE LOCATED OR ANY POLITICAL SUBDIVISION THEREOF, OR (D) THE PRESENCE OF WHICH ON THE PREMISES CAUSES OR THREATENS TO CAUSE A NUISANCE UPON THE PREMISES OR TO ADJACENT PROPERTIES OR POSES OR THREATENS TO POSE A HAZARD TO THE HEALTH OR SAFETY OF PERSONS ON OR ABOUT THE PREMISES, OR (E) WHICH CONTAINS GASOLINE, DIESEL FUEL OR OTHER PETROLEUM HYDROCARBONS, OR (F) WHICH CONTAINS POLYCHLORINATED BIPHENYLS (PCBS), ASBESTOS, LEAD OR UREA FORMALDEHYDE FOAM INSULATION.
- THE CONTRACTOR SHALL FIELD LOCATE ALL EXISTING UTILITIES AS TO SIZE, LOCATION, AND ELEVATION. THE CONTRACTOR SHALL NOTIFY THE ENGINEER OF ANY AND ALL CONFLICTS, DEVIATIONS OR OMISSIONS TO THESE CONSTRUCTION DRAWINGS PRIOR TO BEGINNING CONSTRUCTION.
- IF ANY TESTING, INSPECTION OR APPROVAL REVEAL DEFECTIVE WORK, CONTRACTOR SHALL NOT BE ALLOWED TO REINSTATE ANY PORTION OF THE WORK UNLESS THE DEFECTIVE WORK IS ENTITLED TO DEDUCT FROM THE CONTRACT PRICE, BY ISSUING A CHANGE ORDER, OWNER'S COSTS ARISING OUT OF THE DEFECTIVE WORK, INCLUDING COSTS OF REPEATED PROCEDURES, COMPENSATION FOR ENGINEER'S AND DESIGN ENGINEER'S SERVICES AND ALL OTHER RELATED COSTS.

ADDITIONAL NOTES

- ELEVATIONS SHOWN HEREON ARE BASED ON NGS (NATIONAL GEODETIC SURVEY) DATUM PER BENCHMARK NUMBER GPS 0184, ELEVATION = 37.61 (NAVD 1988), NGS MONUMENT 400± EAST OF S.R. 417 ON S.R. 434.

LEGEND

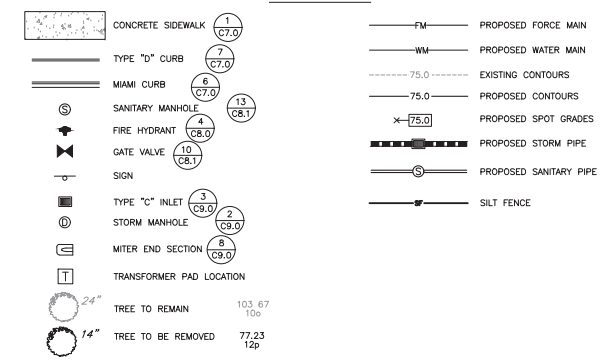

HANDICAP ACCESSIBILITY NOTES:

- ALL CONSTRUCTION MUST MEET OR EXCEED ALL REQUIREMENTS AS OUTLINED IN THE AMERICANS WITH DISABILITIES ACT (ADA) AND THE FLORIDA ACCESSIBILITY CODE, MOST RECENT EDITIONS. BOTTOM OF CURB RAMP ELEVATION (B.O. RAMP) IS RELATIVE TO EACH CURB RAMP CONDITION. ACTUAL ELEVATIONS SHALL BE BASED ON EXISTING GRADE OF CURB FLOW LINE AT THE B.O. RAMPS.
- TOP OF CURB ELEVATION ADJACENT TO B.O. RAMP = 0.50 FT. MAX. UNLESS OTHERWISE NOTED.
- ADA REQUIREMENTS SUPERSEDE SPOT GRADES AT LOT LINES. CONTRACTOR TO CUT BACK SLOPE AT 3:1 OR FLATER AS NEEDED FOR RAMP AND SIDEWALK CONNECTION.
- REFER TO PLAN SHEETS AND SECTIONS FOR LOCATIONS AND SIDEWALK WIDTHS.
- THE DETECTABLE WARNING STRIP SHALL CONSIST OF A 24 INCH WIDE TACTILE PATTERN OF RAISED TRUNCATED DOMES (ALTERED PATTERN). DOMES SHALL HAVE A DIAMETER OF 0.9 INCH, A HEIGHT OF 0.2 INCH, AND A CENTER TO CENTER SPACING OF 2.35 INCHES. THE RAMP DETECTABLE WARNING STRIP SHALL BE CONTRASTING IN COLOR. THE MATERIAL USED TO PROVIDE CONTRAST SHALL CONTRAST BY AT LEAST:
- THE CROSS SLOPE OF RAMP SURFACES AND ADJACENT STREET GRADES SHALL BE NO MORE THAN 1:50 OR 2% MAXIMUM.
- CURB RAMPS CONSTRUCTED BY THE CONTRACTOR SHALL MEET ALL CURRENT APPLICABLE A.D.A. REQUIREMENTS AND SHALL HAVE DETECTABLE WARNING CONPLYING WITH A.D.A. REQUIREMENTS. ACCESSIBILITY ROUTES SHALL MEET ALL APPLICABLE A.D.A. REQUIREMENTS.
- CONTRACTOR TO REFER TO MUNICIPALITY DETAILS AS NEEDED.
- DRIVEWAY/ROADWAY CROSS SLOPES AT CROSSEWALKS SHALL BE MAXIMUM 2% PER ADA REQUIREMENTS.
- SIDEWALK CROSS SLOPES SHALL BE MAXIMUM 2% PER ADA REQUIREMENTS.
- CURB RAMP FLARES & LANDINGS SHALL MEET ADA REQUIREMENTS.
- ACCESSIBLE ROUTE WITH RUNNING SLOPES GREATER THAN 1:20 IS A RAMP AND SHALL COMPLY WITH ADA RAMP REQUIREMENTS.
- IT IS THE CONTRACTOR'S SOLE RESPONSIBILITY TO MEET ALL CURRENT ADA STANDARDS. CONTRACTOR SHALL REFER TO FDOT STANDARDS. (INDEX 304, MOST CURRENT EDITION)

RECORD DRAWING AS-BUILT REQUIREMENTS:

AS-BUILT DRAWINGS SHALL BE PREPARED BY AND CERTIFIED (SIGNED AND SEALED) BY A REGISTERED SURVEYOR, AND SHALL BE PROVIDED TO THE ENGINEER OF RECORD UPON COMPLETION OF THE PROJECT. THE PROJECT SITE IMPROVEMENTS A MINIMUM OF 1 WEEK PRIOR TO CONTRACTORS ATTEMPT FOR FINAL CERTIFICATE OF OCCUPANCY (CO). AS-BUILT DRAWINGS SHALL REFLECT ANY CHANGES TO THE IMPROVEMENTS MADE DURING CONSTRUCTION AND MUST MEET THE MINIMUM REQUIREMENTS OF ALL REGULATORY AGENCIES HAVING JURISDICTION AS WELL AS THE CRITERIA OUTLINED BELOW. BOTH THE ORIGINAL DESIGN AND REVISED AS-BUILT DATA, AS APPLICABLE, MUST BE CLEARLY SHOWN. THE AS-BUILT DRAWINGS MUST BE CLEARLY LABELED AS AS-BUILT OR RECORD DRAWING. THE FOLLOWING INFORMATION, AT A MINIMUM, SHALL BE CERTIFIED ON THE AS-BUILT DRAWINGS:

- WATER DISTRIBUTION SYSTEM:
- LOCATION AND DIMENSIONS OF PIPES, VALVES, FITTINGS, CHANGE OF DIRECTION, AND OTHER ASSOCIATED FACILITIES.
- WASTEWATER COLLECTION/TRANSMISSION SYSTEM:
- LOCATION, DIMENSION, AND INVERT ELEVATIONS OF PIPES, MANHOLES (INCLUDING RIM ELEVATION), LIFTSTATION, FOREPANEL, FITTINGS, CHANGE IN DIRECTION AND OTHER ASSOCIATED FACILITIES.
- PAVING AND DRAINAGE SYSTEM:
- DIMENSIONS AND ELEVATIONS OF ALL DISCHARGE STRUCTURES INCLUDING ALL WEIRS, SLOTS, GATES, PIPES, AND SKIMMERS;
 - LOCATIONS, DIMENSIONS, AND ELEVATIONS OF ALL FILTER, EXFILTRATION, OR UNDERDRAIN SYSTEMS INCLUDING CLEANOUTS, PIPES, CONNECTIONS TO CONTROL STRUCTURES, AND POINTS OF DISCHARGE TO THE RECEIVING WATERS;
 - DIMENSIONS, ELEVATIONS, CONTOURS, OR CROSS-SECTIONS OF ALL STORMWATER TREATMENT POND STORAGE AREAS SUFFICIENT TO DETERMINE STAGE-STORAGE RELATIONSHIPS OF THE STORAGE AREA, AND THE POND DEPTH AND VOLUME BELOW THE CONTROL WATER ELEVATION FOR NORMALLY MET SYSTEMS;
 - DIMENSIONS, ELEVATIONS, CONTOURS, FINAL GRADES, OR CROSS-SECTIONS OF THE DRAINAGE SYSTEM IMPROVEMENTS TO DETERMINE FLOW DIRECTIONS AND CONVEYANCE OF RUNOFF TO THE TREATMENT SYSTEM;
 - DIMENSIONS, ELEVATIONS, CONTOURS, FINAL GRADES, OR CROSS-SECTIONS OF ALL CONVEYANCE SYSTEMS UTILIZED TO CONVEY OFF-SITE RUNOFF AROUND THE SYSTEM;
 - EXISTING WATER ELEVATION OF SURFACE WATERS AND THE DATE DETERMINED;
 - ELEVATION AND LOCATION OF BENCHMARK'S FOR THE SURVEY.

- ADA FACILITIES:
- ELEVATIONS AT THE FOUR CORNERS OF ALL HANDICAP PARKING SPACES AND ADJACENT LOADING AISLES.
 - ELEVATIONS AND LOCATIONS FOR ALL ACCESSIBLE RAMPS WHICH ADEQUATELY REFLECT THE BUILT SLOPES.
 - ELEVATIONS AND LOCATIONS ALONG THE PATHS OF CONVEYANCE FOR PEDESTRIAN TRAFFIC AND ALL ADA ACCESSIBLE ROUTES EVERY 25 FT. WHICH ADEQUATELY REFLECT THE SLOPE AND CROSS SLOPE.

UTILITY PROVIDERS

- MARVIN USRY JR. BRIGHT HOUSE NETWORKS, LLC (407) 532-8509
- CLIFTON MULLIS CITY OF WINTER SPRINGS (407) 327-7888
- DAY PARDO CITY OF OVIEDO (407) 971-5690
- SHARON DEAR DUKE ENERGY (407) 805-3321
- DINO FARRUGGIO AT&T DISTRIBUTION (954) 249-0558

CITY OF WINTER SPRINGS GENERAL NOTES

- CITY SITE INSPECTION FEE IS DUE AT THE PRE-CONSTRUCTION MEETING, IN THE AMOUNT OF 1% OF ALL SITEWORK COSTS.
- ALL ROLLOFF CONSTRUCTION DUMPSTERS SHALL BE FURNISHED BY WASTE PRO, PER THE CITY'S SOLID WASTE FRANCHISE AGREEMENT. WASTE PRO CONTACT IS TOM DALY, 321-229-6605.
- NO CONSTRUCTION EQUIPMENT OPERATION BEFORE 7:00 AM PER THE CITY NOISE ORDINANCE.
- ALL SANITARY AND STORM PIPING SYSTEMS SHALL BE VIDEO INSPECTED AT SITE ACCEPTANCE AND AT THE END OF THE 2-YEAR MAINTENANCE PERIOD.
- YARD DRAINAGE SHALL BE SUPPLEMENTED BY ROOF GUTTERS AND/OR YARD DRAINAGE SYSTEMS TO BE INSTALLED BY THE BUILDER AT THE TIME OF CONSTRUCTION.
- NO ONSITE BURNING IS PERMITTED WITHIN THE CITY OF WINTER SPRINGS.

B&S ENGINEERING CONSULTANTS, LLC DBA		APPLAN ENGINEERING, LLC	
2221 LEFF ROAD, SUITE 17		WINTER PARK, FLORIDA 32789	
(407) 960-5868			
GENERAL NOTES			
NORTHERN OAKS SUBDIVISION			
CITY OF WINTER SPRINGS, FLORIDA			
SCALE:	N.T.S.	DRAWN BY:	G. SANDOZ
PROJECT:	CE0-003	DESIGNED BY:	L. GLASSON
SHEET:	C1.0	CHECKED BY:	L. GLASSON
		DATE:	1/24/2017
BOARD OF PROFESSIONAL ENGINEERING CERTIFICATE NO. 28973			

P:\PROJECT DRAWINGS\CED-003 - Northern Oaks Subdivision\SR 434\Drawings\Plan\Drawings Modified: 2/9/2017 By: asanchez

MAINTENANCE OF TRAFFIC NOTES:

1. NO LANE CLOSURES ALLOWED BETWEEN 7AM TO 7PM.
2. MAINTENANCE OF TRAFFIC TO BE SUPERVISED BY A CERTIFIED PERSON.
3. TEST RESULTS ARE REQUIRED UPON REQUEST.
4. THE CONTRACTOR'S SHALL NOTIFY THE DEPARTMENT A MINIMUM OF TWO BUSINESS DAY PRIOR TO ANY LANE CLOSURES OR BEGINNING ANY CONSTRUCTION WITHIN THE FDOT RIGHT-OF-WAY.
5. ALL WORK PERFORMED WITHIN THE FDOT RIGHT-OF-WAY SHALL BE IN ACCORDANCE WITH THE 2016 FDOT DESIGN STANDARDS, 2016 SPECIFICATIONS FOR ROAD AND BRIDGE CONSTRUCTION AND THE 2010 UTILITY ACCOMMODATION MANUAL.
6. ENGINEER'S CERTIFICATION TOGETHER WITH ASBUILT DRAWINGS, IF REQUIRED, TO BE SUBMITTED WITHIN 30 DAYS OF COMPLETION.
7. IT WILL BE THE RESPONSIBILITY OF THE PERMITTEE TO REPAIR ANY DAMAGE TO FDOT FACILITIES CAUSED BY CONSTRUCTION OF THE PROJECT.

SITE PREPARATION/OVER EXCAVATION NOTES:

1. CONTRACTOR TO REFER TO SUBSURFACE EXPLORATION AND GEOTECHNICAL ANALYSIS REPORT FOR LIMITS OF OVER-EXCAVATION AND SUITABLE APPROVED REPLACEMENT FILL WITHIN THE PROJECT LIMITS.

 LIMITS OF ORGANIC/PEAT SOILS PER GEOTECHNICAL REPORT

- PROPERTY BOUNDARY
- SF SILT FENCE
- MAINTENANCE OF TRAFFIC
- EPA "NO IMPACT" WETLAND LINE

NOTE: FOOT SR 434 RIGHT-OF-WAY DEMOLITION SHOWN FOR REFERENCE PURPOSES ONLY. ALL DEMOLITION AND PROPOSED IMPROVEMENTS WITHIN THE RIGHT-OF-WAY SHALL BE PERMITTED THROUGH FDOT.

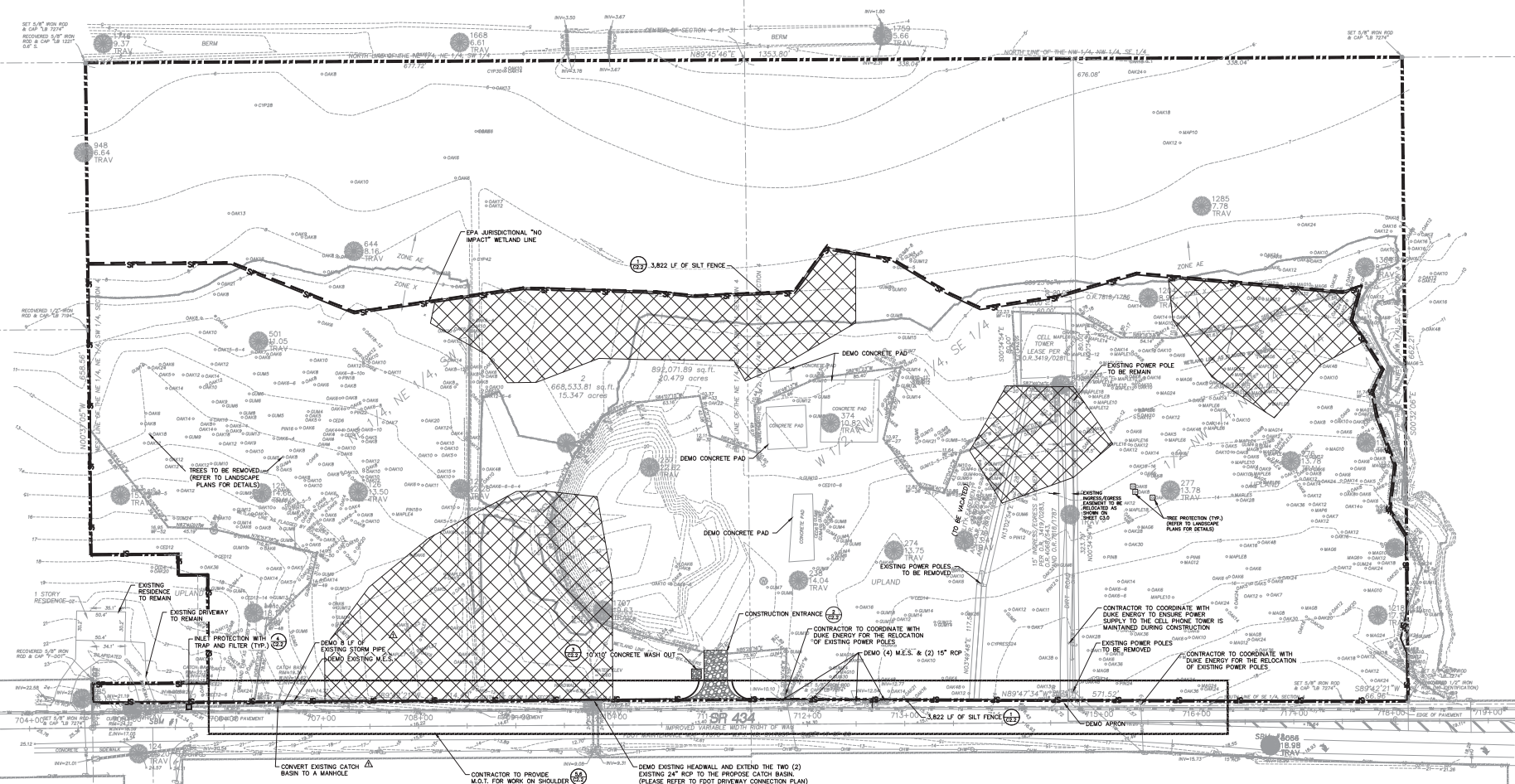
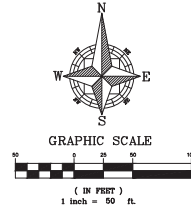

SCALE	1" = 50'
DRAWN	G. SANCHEZ
DESIGNED	L. CLASSON
CHECKED	L. CLASSON
DATE	1/24/2017
PROJECT	EROSION CONTROL, M.O.T. AND DEMOLITION PLAN
SHEET	CE0-003
SHEET	C2.1
BOARD OF PROFESSIONAL ENGINEERING CERTIFICATE NO.	26973
CONTRACTOR	B&S ENGINEERING CONSULTANTS, LLC DBA APPIAN ENGINEERING, LLC
ADDRESS	2221 LEE ROAD, SUITE 17 WINTER PARK, FLORIDA 32789
PHONE	(407) 960-5868
DATE	
DESCRIPTION	

48 HOURS BEFORE DIGGING
 **CALL**
888 or 1-800-432-4770
 AND WE'LL BE THERE TO HELP YOU.
ENGINEER'S PROJECT NO. 36870

MACTAVANDASH/DRIVE

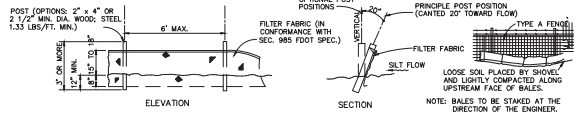

NOTE:
SILT FENCE TO BE PAID FOR UNDER THE CONTRACT UNIT PRICE FOR STAKED SILT FENCE (LF).

1 TYPE III SILT FENCE DETAIL
N.T.S.

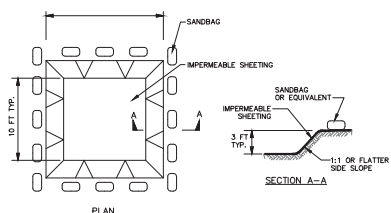

EXCAVATED WASHOUT STRUCTURE

- NOTES:
1. LOCATE WASHOUT STRUCTURE A MINIMUM OF 50 FEET AWAY FROM OPEN CHANNELS, STORM DRAIN INLETS, SENSITIVE AREAS, WETLANDS, BUFFERS AND WATER COURSES AND AWAY FROM CONSTRUCTION TRAFFIC.
 2. SIZE WASHOUT STRUCTURE FOR VOLUME NECESSARY TO CONTAIN WASH WATER AND SOLIDS AND MAINTAIN AT LEAST 4 INCHES OF FREEBOARD. TYPICAL DIMENSIONS ARE 10 FEET X 10 FEET X 3 FEET DEEP.
 3. PREPARE SOIL BASE FREE OF ROCKS OR OTHER DEBRIS THAT MAY CAUSE TEARS OR HOLES IN THE LINER. FOR LINER, USE 10 MIL OR THICKER UV RESISTANT IMPERMEABLE SHEETING, FREE OF HOLES AND TEARS OR OTHER DEFECTS THAT COMPROMISE IMPERMEABILITY OF THE MATERIAL.
 4. PROVIDE A SIGN FOR THE WASHOUT IN CLOSE PROXIMITY TO THE FACILITY.
 5. KEEP CONCRETE WASHOUT STRUCTURE WATER TIGHT. REPLACE IMPERMEABLE LINER IF DAMAGED (E.G., REPTED OR PUNCTURED). EMPTY OR REPLACE WASHOUT STRUCTURE THAT IS 75 PERCENT FULL, AND DISPOSE OF ACCUMULATED MATERIAL PROPERLY. DO NOT REUSE PLASTIC LINER. NET-VOLUME STORED LIQUIDS THAT HAVE NOT EVAPORATED AND DISPOSE OF IN AN APPROVED MANNER. PRIOR TO FORECASTED RAINSTORMS, REMOVE LIQUIDS OR COVER STRUCTURE TO PREVENT OVERFLOWS. REMOVE HARDENED SOLIDS, WHEELS OR BROKEN UP FOR DISPOSAL OR RECYCLING. MAINTAIN RUNOFF DIVERSION AROUND EXCAVATED WASHOUT STRUCTURE UNTIL STRUCTURE IS REMOVED.

3 CONCRETE WASH OUT
N.T.S.

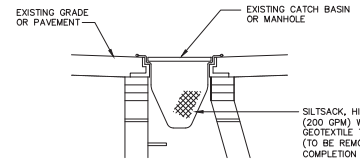

4 INLET TRAP AND FILTER
N.T.S.

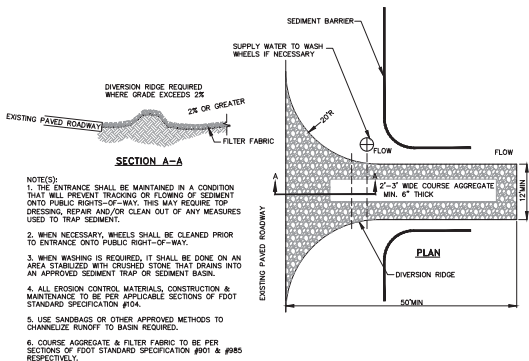

2 TEMPORARY CONSTRUCTION ENTRANCE DETAIL
N.T.S.

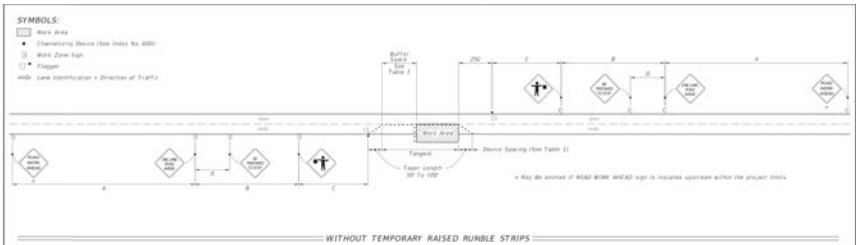

- GENERAL NOTES:
1. Channelizing Device (See Table 1) shall be used in accordance with these notes and the following sheets:
 2. Buffer Zone (See Table 1)
 3. Flagger
 4. Lane Identification - Direction of Traffic
- TABLE I
DEVICE SPACING
- | Post Spacing | Maximum Spacing
at 45 Degree or
Laboratory Markers | Maximum Spacing
at 90 Degree or
Laboratory Markers | Distance
Between
Signs | Buffer
Length |
|--------------|--|--|------------------------------|------------------|
| 25 | 50 | 50 | 100 | 100 |
| 30 | 60 | 60 | 120 | 120 |
| 40 | 80 | 80 | 160 | 160 |
| 50 | 100 | 100 | 200 | 200 |
| 60 | 120 | 120 | 240 | 240 |
| 75 | 150 | 150 | 300 | 300 |
| 100 | 200 | 200 | 400 | 400 |
| 125 | 250 | 250 | 500 | 500 |
| 150 | 300 | 300 | 600 | 600 |
| 200 | 400 | 400 | 800 | 800 |
| 250 | 500 | 500 | 1000 | 1000 |
| 300 | 600 | 600 | 1200 | 1200 |
| 400 | 800 | 800 | 1600 | 1600 |
| 500 | 1000 | 1000 | 2000 | 2000 |
| 600 | 1200 | 1200 | 2400 | 2400 |
| 750 | 1500 | 1500 | 3000 | 3000 |
| 1000 | 2000 | 2000 | 4000 | 4000 |
| 1250 | 2500 | 2500 | 5000 | 5000 |
| 1500 | 3000 | 3000 | 6000 | 6000 |
- CONDITIONS:
WHERE ANY VEHICLE, EQUIPMENT, MATERIALS OR TRAFFIC ACTIVITIES INFRINGE THE AREA BETWEEN THE CHANNELIZING DEVICE LINE AND THE CENTERLINE OF THE ROAD, THE END OF THE TRAFFIC WORK AREA SHALL BE MAINTAINED.

5 MAINTENANCE OF TRAFFIC
N.T.S.

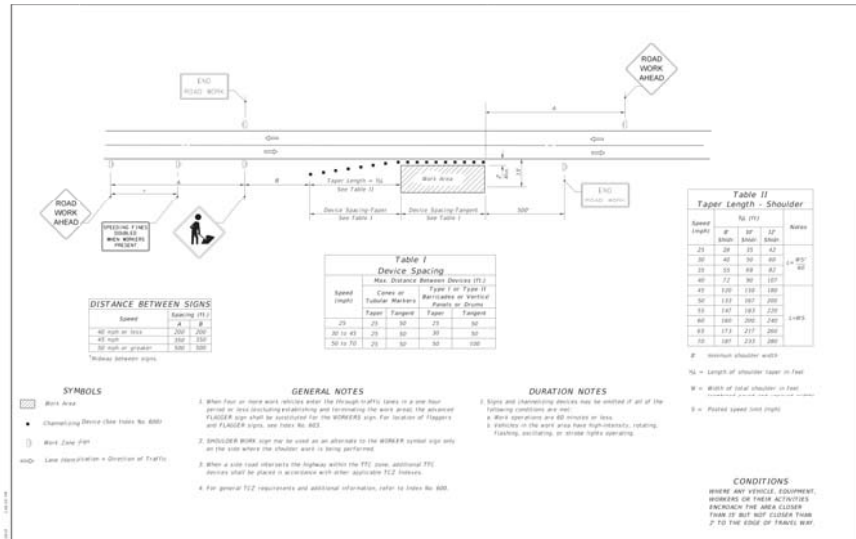

- GENERAL NOTES:
1. When four or more work vehicles enter the through-lane (FL) lanes in a one-hour period or when channelizing equipment and materials are used, the minimum FLAGGER sign shall be maintained for the WORKER sign for location of flaggers and FLAGGER signs, see Table No. 602.
 2. Shoulder work signs may be used as an alternate to the WORKER sign only on the side where the shoulder work is being performed.
 3. When a side road intersects the highway within the FTE zone, additional FTE devices shall be placed in accordance with other applicable FTE devices.
 4. For general FTE requirements and additional information, refer to Table No. 602.
- TABLE II
TAPER LENGTH - SHOULDER
- | Speed (mph) | No. (ft) | Width |
|-------------|----------|-------|
| 25 | 100 | 100 |
| 30 | 120 | 120 |
| 40 | 160 | 160 |
| 50 | 200 | 200 |
| 60 | 240 | 240 |
| 70 | 280 | 280 |
| 80 | 320 | 320 |
| 90 | 360 | 360 |
| 100 | 400 | 400 |
- CONDITIONS:
WHERE ANY VEHICLE, EQUIPMENT, MATERIALS OR TRAFFIC ACTIVITIES INFRINGE THE AREA CLOSER THAN 10 FEET TO THE EDGE OF TRAFFIC WORK AREA.

6 MAINTENANCE OF TRAFFIC
N.T.S.

P:\PROJECT DRAWINGS\CED-003 - Northern Oaks Subdivision\KSP Drawings\Shop\WorkArea\05 Final Engineering Plan\Erosion Control\M.O.T. Details.dwg Modified: 2/6/2017 By: cconner

SCALE	N.T.S.	PROJECT	CE0-003	SHEET	C2.2
DRAWN BY	G. SANDHEZ	DESIGNED BY	L. GLASSON	CHECKED BY	L. GLASSON
DATE	1/24/2017	DESCRIPTION			
BOARD OF PROFESSIONAL ENGINEERING CERTIFICATE NO. 28973 BAS ENGINEERING CONSULTANTS, LLC DBA APPIAN ENGINEERING, LLC 2221 LEE ROAD, SUITE 17 WINTER PARK, FLORIDA 32789 CITY OF WINTER SPRINGS, FLORIDA (407) 960-5868					

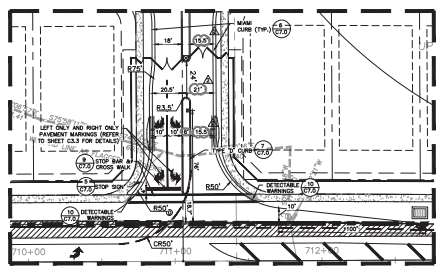

FRONT ENTRANCE DETAIL
1" = 40'

TYPICAL LOT SIZE/
PROPOSED
BUILDING PAD

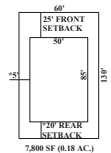

CORNER LOT
SIZE/ BUILDING
PAD FOR LOTS

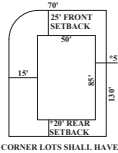

CORNER LOTS SHALL HAVE AN
ADDITIONAL 15% LOT AREA
7,800 SF X 1.15 = 8,970 SF (0.21 AC.)

* SPECIAL EXCEPTION/WAIVER SUBMITTED TO CITY OF WINTER
SPRINGS WITH PSP REVIEW

Curve Table			
Curve #	Chord Length	Chord Direction	Radius
C1	35.36'	S45°17'39"E	25.00'
C2	15.81'	S18°08'27"W	25.00'
C3	15.30'	S84°26'18"E	75.00'
C4	25.58'	S68°45'54"E	75.00'
C5	37.59'	S32°19'51"E	75.00'
C6	22.54'	S91°0'36"E	75.00'
C7	8.29'	S3°41'12"W	50.00'
C8	37.96'	S30°45'08"W	50.00'
C9	5.74'	N66°42'05"E	50.00'
C10	35.28'	N45°24'52"W	25.00'
C11	28.87'	N34°43'43"E	25.00'
C12	19.08'	S42°06'34"W	25.00'
C13	57.83'	S55°00'39"W	50.00'

Curve Table			
Curve #	Chord Length	Chord Direction	Radius
C14	19.08'	S42°06'34"W	25.00'
C15	42.84'	N64°35'23"E	50.00'
C16	27.12'	N23°05'11"W	35.00'
C17	35.51'	N44°57'24"E	25.00'
C18	22.36'	S63°08'27"W	25.00'
C19	26.46'	N68°05'11"W	35.00'
C20	15.81'	N52°53'42"W	75.00'
C21	49.96'	N83°02'09"E	50.00'
C22	90.78'	S1°47'22"E	50.00'
C23	90.21'	S25°13'01"E	50.00'
C24	65.84'	N23°16'19"W	100.00'

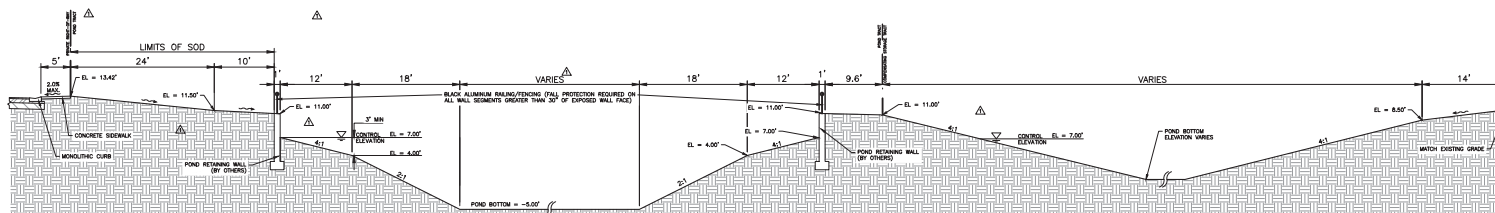
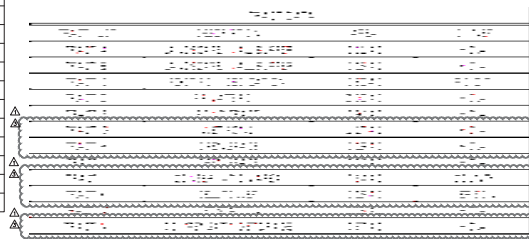

SECTION A-A
N.T.S.

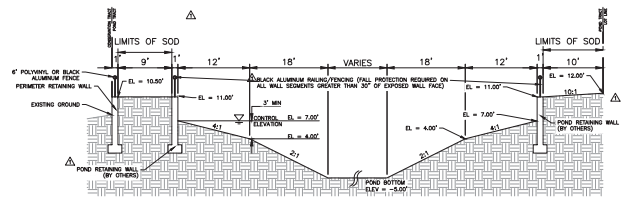

SECTION B-B
N.T.S.

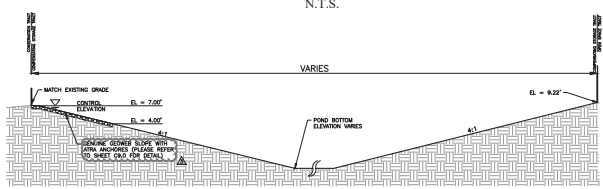

SECTION C-C
N.T.S.

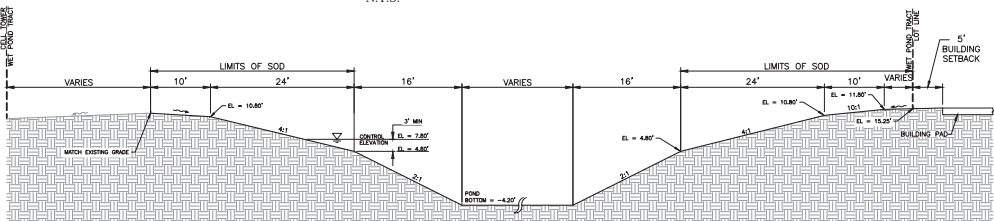

SECTION D-D
N.T.S.

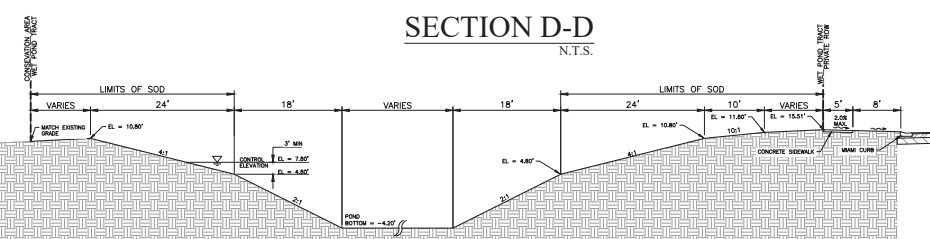

SECTION E-E
N.T.S.

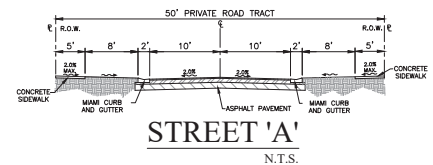

STREET 'A'
N.T.S.

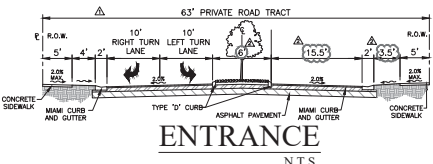

ENTRANCE
N.T.S.

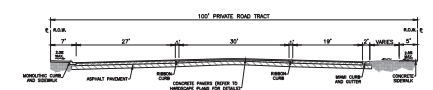

CUL-DE-SACS
N.T.S.

B&S ENGINEERING CONSULTANTS, LLC DBA APPIAN ENGINEERING, LLC		2221 LEE FLOID, SUITE 17 WINTER PARK, FLORIDA 32789 (407) 960-5868	
CROSS SECTION		NORTHERN OAKS SUBDIVISION CITY OF WINTER SPRINGS, FLORIDA	
DRAWN:	G. SANDRIZ	SCALE:	N.T.S.
DESIGNED:	L. GLASSON	PROJECT:	CE0-003
CHECKED:	L. GLASSON	SHEET:	C3.1
DATE:	1/24/2017	BOARD OF PROFESSIONAL ENGINEERING CERTIFICATE NO. 28973	

P:\PROJECT DRAWINGS\CED-003 - Northern Oaks Subdivision\SP Final\Engineering\Plan\Geotech\Plan.dwg Modified:2/24/2017 By:spaschek

P:\PROJECT DRAWINGS\CED-003 - Northern Oaks Subdivision S.P. Drawings\Signage\Signage\Signage Plan.dwg Modified:2/23/2017 By:sanchez

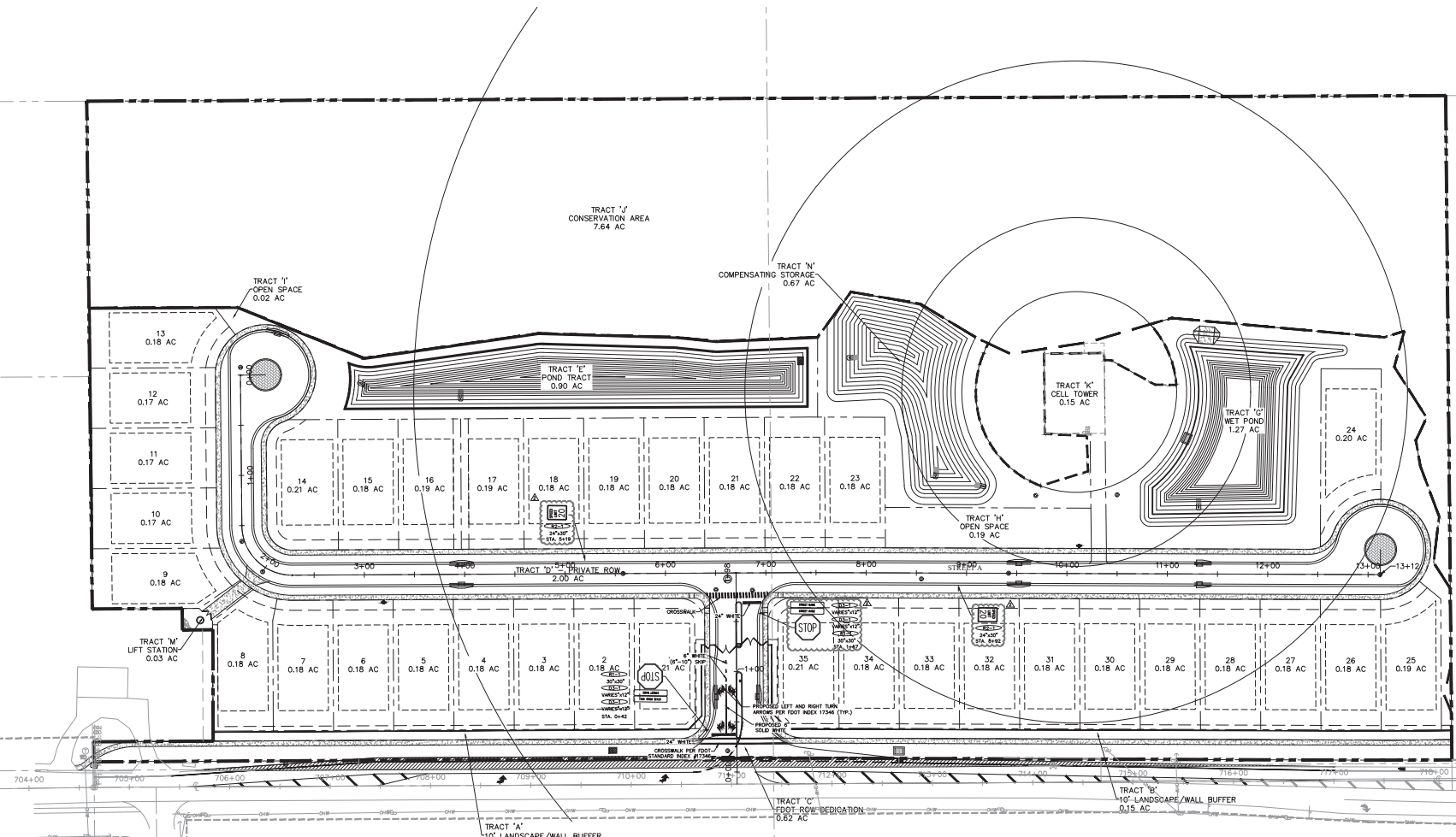
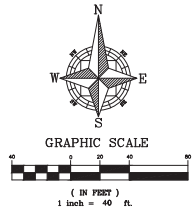

SCALE	1" = 40'
PROJECT	CED-003
SHEET	C3.3
DATE	1/24/2017
DRAWN	G. SANCHEZ
DESIGNED	L. GLASSON
CHECKED	L. GLASSON
DATE	1/24/2017
DESCRIPTION	SIGNAGE AND STRIPING PLAN
CONTRACTOR	B&S ENGINEERING CONSULTANTS, LLC DBA APPIAN ENGINEERING, LLC
PROJECT ADDRESS	2221 LEE ROAD, SUITE 17 WINTER PARK, FLORIDA 32789 (407) 960-5868
PROJECT NO.	
DATE	
REV	
NO.	
DESCRIPTION	

BOARD OF PROFESSIONAL ENGINEERING CERTIFICATE NO. 28973



GENERAL UTILITY NOTES:

- BACTERIOLOGICAL TESTS WITH CHLORINE RESIDUALS INDICATED (TAKEN ON TWO CONSECUTIVE DAYS) SHALL BE CONDUCTED AT EVERY TAP CONNECTION AND EVERY LOCATION INDICATED WITHIN THESE PLANS. RESULTS OF THE BACTERIOLOGICAL TESTS SHALL BE PROVIDED TO THE ENGINEER OF RECORD IMMEDIATELY UPON COMPLETION. BACTERIOLOGICAL TEST RESULTS SHALL BE CONSIDERED UNACCEPTABLE IF THE TESTS WERE COMPLETED MORE THAN 30 DAYS BEFORE THE ENGINEER RECEIVED THE RESULTS.
- ALL WATERMANS SHALL BE INSTALLED A MINIMUM OF 36" BELOW FINISHED GRADE.
- ALL WATERMANS AND FIRELINES PIPES SHALL BE RESTRAINED VIA MECHANICAL JOINTS.
- WATER MAIN PVC PIPES LESS THAN 4 INCHES MUST CONFORM TO THE SPECIFICATIONS OF ASTM 1785 (SCHEDULE 40, 80, 120) OR ASTM 2241 SDR21 AND MUST BEAR THE NSF LOGO ON EACH INSTALLED LENGTH.
- UNDERGROUND MARKING TAPE FOR ALL SANITARY FORCEMANS SHALL BE INSTALLED 4 TO 8 INCHES BELOW THE FINISHED GRADE SURFACE DIRECTLY OVER THE PIPELINE. MARKER TAPE SHALL BE MADE OF AN INERT POLYETHYLENE MATERIAL HAVING A MINIMUM THICKNESS OF 4 MILS AND BE COLOR CODED "SAFETY GREEN".
- CONTRACTOR SHALL CONDUCT AND PROVIDE RESULTS IMMEDIATELY TO THE ENGINEER OF RECORD FOR PRESSURE AND LEAKAGE TESTS ON THE FORCE MAIN TRUNK LINE ONCE THE PRESSURE SEWER HAS BEEN INSTALLED AND PARTIALLY BACKFILLED. FINAL BACKFILL AND COMPACTION SHALL NOT COMMENCE UNTIL APPROVAL OF THE PRESSURE AND LEAKAGE TESTS HAS BEEN PROVIDED BY THE ENGINEER OF RECORD.
- FOLLOWING SATISFACTORY PRESSURE TEST RESULTS, THE CONTRACTOR SHALL DISINFECT ALL SECTIONS OF THE WATER DISTRIBUTION SYSTEM AND RECEIVE APPROVAL THEREOF FROM APPROPRIATE AGENCIES PRIOR TO PLACING THE SYSTEM INTO SERVICE.
- FIRE HYDRANTS SHALL BE PLACED A MINIMUM OF 3 FT. AND A MAXIMUM OF 5 FT. FROM THE CURB OR PAVED ROAD SURFACE UNLESS OTHERWISE APPROVED. NO FENCE, TREE, POST, SHRUB, OR OTHER OBJECT WHICH COULD BLOCK THE HYDRANT FROM NORMAL VIEW OR OBSTRUCT THE HYDRANT'S USE SHALL BE LOCATED WITHIN FOUR (4) FEET OF THE HYDRANT. THE FOUR-AND-ONE-HALF INCH (4-1/2") LARGE VOLUME CONNECTION SHALL FACE THE NEAREST ROADWAY. THE CENTER OF THE STEAMER PORT SHALL BE 18 INCHES MINIMUM AND 24 INCHES MAXIMUM ABOVE FINISHED GRADE.
- ALL FIRE HYDRANT LEADS SHALL HAVE AN INSIDE DIAMETER OF AT LEAST SIX INCHES AND INCLUDE AUXILIARY VALVES.
- WHEN NECESSARY, DEWATERING SHALL BE PROVIDED TO KEEP THE GROUNDWATER ELEVATION A MINIMUM OF 6 INCHES BELOW MAIN BEING LAID.
- ALL UTILITIES SHALL BE LAID ON A FIRM FOUNDATION WITH ALL UNSUITABLE MATERIAL (MUCK, ROCK, COULINA, ETC.) REMOVED AND REPLACED WITH CLEAN GRANULAR MATERIAL.
- TRENCHES SHALL BE BACKFILLED WITH MATERIAL ACCEPTABLE TO THE CITY WITH A MINIMUM COMPACTION OF 98% IN PAVED AREAS AND 95% IN UNPAVED AREAS IN ACCORDANCE WITH AASHTO T-180 MODIFIED PROCTOR TEST.
- IT SHALL BE THE CONTRACTORS RESPONSIBILITY TO ENSURE THAT TRENCH COMPACTION TESTS BE PROVIDED AT POINTS 12 INCHES ABOVE THE PIPE AND AT 12 INCHES VERTICAL INTERVALS TO FINISH GRADE, AT A MINIMUM SPACING OF EVERY 300 FEET.
- ALL WATER SERVICE ENDINGS SHALL BE MARKED WITH A 2" X 4" LUMBER (PRESSURE TREATED) EXTENDING 4 FEET ABOVE GRADE, WITH WATER SERVICES SECURED 12" MAXIMUM ABOVE THE GROUND.
- ALL WATER VALVES, INCLUDING CONCRETE COLLAR (WITH DEBRIS CAP), SHALL BE ADJUSTED TO FINISHED GRADE AND THE VALVE BOX LID, PAINTED BLUE TO MAKE THEM PLAINLY VISIBLE.
- UPON FINAL ACCEPTANCE OF NEW WATER SYSTEMS, WATER VALVES SHALL BE COMPLETELY OPENED BY PUBLIC UTILITIES PERSONNEL. AT NO TIME SHALL CONTRACTOR OPERATE ANY EXISTING VALVES WITHOUT A CITY INSPECTOR PRESENT.
- ALL WATER MAINS SHALL BE NSF-APPROVED FOR POTABLE WATER USE.
- PIPE USED IN WATER DISTRIBUTION SYSTEMS SHALL BE EITHER POLYVINYL CHLORIDE (PVC), OR DUCTILE IRON PIPE (DIP).

- ALL PVC PIPE OF NOMINAL DIAMETER FOUR (4) INCHES THROUGH TWELVE (12) INCHES SHALL BE MANUFACTURED IN ACCORDANCE WITH AWWA STANDARD C900, LATEST EDITION. THE PVC PIPE SHALL HAVE A MINIMUM WORKING PRESSURE RATING OF 150PSI AND SHALL HAVE A DIMENSION RATIO (DR) OF 18.
- ALL DUCTILE IRON PIPE SHALL BE MANUFACTURED IN ACCORDANCE WITH AWWA A21.51/C151 AND HAVE A MINIMUM 350 PRESSURE CLASS RATING.
- PIPE USED IN GRAVITY SEWER CONSTRUCTION SHALL BE POLYVINYL CHLORIDE (PVC) OR DUCTILE IRON PIPE (DIP), WHERE REFERENCE IS MADE TO AN ASTM, ANSI, OR AASHTO DESIGNATION, IT SHALL BE THE LATEST REVISION.
 - PVC GRAVITY SEWER PIPE (4 INCH - 15 INCH), ASTM D3034, SDR 35 - UNIFORM MINIMUM PIPE STIFFNESS AT FIVE (5) PERCENT DEFLECTION SHALL BE 46PSI. THE JOINTS SHALL BE INTEGRAL BELL ELASTOMERIC GASKET JOINTS MANUFACTURED IN ACCORDANCE WITH ASTM D3212 AND ASTM F477 APPLICABLE UN-BELL PLASTIC PIPE ASSOCIATION STANDARD IS UN-B-4. ALL PVC PIPE SHALL BEAR THE NSF-DW SEAL AND BE GREEN IN OVERALL COLOR. THE MINIMUM STANDARD LENGTH OF PIPE SHALL BE THIRTEEN (13) FEET.
 - DUCTILE IRON PIPE SHALL CONFORM TO AWWA A21.51/C151, CLASS THICKNESS DESIGNED PER AWWA/A21.51/0150, WITH MECHANICAL OR PUSH ON JOINTS. AN INTERIOR PROTECTIVE LINING OF COAL TAR EPOXY SHALL BE PROVIDED WITH A MINIMUM DRY THICKNESS OF 30 MILS. DUCTILE IRON GRAVITY SEWERS, WHERE REQUIRED BY THE CITY BASED ON GEOTECHNICAL INVESTIGATIONS, SHALL BE WRAPPED WITH POLYETHYLENE FILM, AWWA C105. SEE APPENDIX C. THE MINIMUM STANDARD LENGTH OF PIPE SHALL BE EIGHTEEN (18) FEET.

SP#

WATER SYSTEM TESTING REQUIREMENTS:

- THE CONTRACTOR SHALL PERFORM HYDROSTATIC TESTING OF ALL WATER DISTRIBUTION SYSTEMS, AS SET FORTH IN THE FOLLOWING AND SHALL CONDUCT SAID TESTS IN THE PRESENCE OF REPRESENTATIVES FROM THE CITY AND/OR OTHER AUTHORIZED AGENCIES. THE CONTRACTOR SHALL PROVIDE 48 HOURS ADVANCED NOTICE TO THE CITY OF WINTER SPRINGS PRIOR TO TESTING OF THE POTABLE WATER SYSTEM.
- ALL TESTING REQUIRED BY THE CITY SHALL BE PAID FOR BY THE DEVELOPER / CONTRACTOR.
- ALL PROPOSED WATER MAINS SHALL BE TESTED AND CLEARED FOR SERVICE IN ACCORDANCE WITH THE LATEST AWWA STANDARDS AND THE FLORIDA DEPARTMENT OF ENVIRONMENTAL PROTECTION REQUIREMENTS.
- PRIOR TO HYDROSTATIC TESTING A PRELIMINARY FLUSHING SHALL BE REQUIRED THROUGH FULL DIAMETER FLUSHING OR SWABING. PRELIMINARY FLUSHING/SWABING SHALL BE PERFORMED PER AWWA C901 STANDARD - "DISINFECTING WATER MAINS". ALL PIPING SHALL BE THOROUGHLY CLEANED AND FLUSHED PRIOR TO TESTING TO CLEAR THE LINES OF ALL FOREIGN MATTER. WHILE THE PIPING IS BEING FILLED WITH WATER, CARE SHALL BE EXERCISED TO PERMIT THE ESCAPE OF AIR FROM EXTREMITIES ALONG THE TEST SECTION.
- HYDROSTATIC TESTING SHALL CONSIST OF PRESSURE TEST AND LEAKAGE TEST AND APPURTENANCES TO BE TESTED SHALL BE WITHIN SECTIONS BETWEEN VALVES, NOT EXCEEDING 2,000 FEET, UNLESS ALTERNATE METHODS HAVE RECEIVED PRIOR APPROVAL FROM THE CITY. TESTING SHALL NOT PROCEED UNTIL CONCRETE THROUST BLOCKS ARE IN PLACE AND CURED, OR OTHER RESTRAINING DEVICES INSTALLED.
- HYDROSTATIC TESTING SHALL BE PERFORMED AT 150 POUNDS PER SQUARE INCH PRESSURE, UNLESS OTHERWISE APPROVED BY THE CITY, FOR A PERIOD OF NOT LESS THAN TWO (2) HOURS.
- THE ALLOWABLE RATE OF LEAKAGE SHALL BE LESS THAN THE NUMBER OF GALLONS PER HOUR DETERMINED BY THE FOLLOWING FORMULA:

$$L = \frac{SD^2VF}{148,000}$$

WHERE:
 L = ALLOWABLE LEAKAGE, IN GALLONS PER HOUR
 S = LENGTH OF PIPE TESTED, IN FEET
 D = NOMINAL DIAMETER OF PIPE, IN INCHES
 V = AVERAGE TEST PRESSURE DURING THE LEAKAGE TEST, IN POUNDS PER SQUARE INCH (GAUGE)
- SHOULD THE TEST FAIL, NECESSARY REPAIRS SHALL BE ACCOMPLISHED BY THE CONTRACTOR AND THE TEST REPEATED UNTIL WITHIN PASSING LIMITS. THE CONTRACTOR SHALL FURNISH ALL THE NECESSARY LABOR, PUMPS, GAUGES AND ALL OTHER ITEMS NECESSARY TO CONDUCT THE REQUIRED WATER DISTRIBUTION SYSTEM TESTING AND PERFORM NECESSARY REPAIRS.

SEWER SYSTEM TESTING REQUIREMENTS:

- THE CONTRACTOR SHALL PERFORM TESTING OF ALL SANITARY SEWAGE GRAVITY COLLECTION SYSTEMS, AS SET FORTH IN THE FOLLOWING AND SHALL CONDUCT SAID TESTS IN THE PRESENCE OF REPRESENTATIVES FROM THE CITY AND/OR OTHER AUTHORIZED AGENCIES. THE CONTRACTOR SHALL PROVIDE 48 HOURS ADVANCED NOTICE PRIOR TO TESTING OF THE WASTEWATER DISTRIBUTION SYSTEM.
- ALL TESTING REQUIRED BY THE CITY SHALL BE PAID FOR BY THE DEVELOPER / CONTRACTOR.
- GRAVITY MAINS AND LATERALS SHALL BE INSPECTED WITH CCTV FOR ALIGNMENT, GRADE VARIATIONS, SEPARATED PIPES, LEAKS, DEFLECTION, CRACKED, BROKEN OR OTHERWISE DEFECTIVE PIPE TO ENSURE OVERALL PIPE INTEGRITY. THE APPROVED CCTV INSPECTION CONTRACTOR SHALL SUBMIT THE REPORT TO THE UTILITIES DEPARTMENT AS REQUIRED BY THE CITY. EDR REVIEW, ALONG WITH THE AS-BUILT DRAWINGS. THE DVD IS TO BE SUBMITTED TO THE CITY ALONG WITH THE REPORT AND RECORD DRAWINGS.

ADDITIONAL NOTES:

- ALL FORCE MAIN IS REQUIRED TO BE DR11 AT A MINIMUM.

FDEP UTILITY CONSTRUCTION NOTES:

- NOTE TO THE UTILITY: PURSUANT TO 62-555.345; DO NOT PROVIDE WATER SERVICE TO THIS PROJECT (OTHER THAN FLUSHING/TESTING) UNTIL THE DEPARTMENT OF ENVIRONMENTAL PROTECTION HAS ISSUED A LETTER OF CLEARANCE OR THE UTILITY SHALL BE SUBJECT TO ENFORCEMENT ACTION.
- THE PERMITEE WILL PROMPTLY NOTIFY THE DEPARTMENT UPON SALE OR LEGAL TRANSFER OF THE PERMITTED FACILITY.
- ALL WATER MAINS AND APPURTENANCES SHALL BE DISINFECTED AND BACTERIOLOGICALLY EVALUATED IN ACCORDANCE WITH RULE 62-555.340, F.A.C.
- ALL WATER MAIN PIPE INCLUDING FITTINGS SHALL BE COLOR CODED OR MARKED USING BLUE AS A PRECAUTION TO DIFFERENTIATE DRINKING WATER FROM OTHER UTILITIES. UNDERGROUND UNDERGROUND PLASTIC PIPE SHALL BE SOLID-WALL BLUE PIPE. SHALL HAVE A CO-EXTRUDED BLUE EXTERNAL SKIN, OR SHALL BE WHITE OR BLACK PIPE WITH BLUE STRIPES INCORPORATED INTO, OR APPLIED TO, THE PIPE WALL; AND UNDERGROUND METAL OR CONCRETE PIPE SHALL HAVE BLUE STRIPES APPLIED TO THE PIPE WALL. PIPE STRIPES DURING MANUFACTURING OF THE PIPE SHALL HAVE CONTINUOUS STRIPES THAT RUN PARALLEL TO THE AXIS OF THE PIPE. THAT ARE LOCATED AT NO GREATER THAN 90-DEGREE INTERVALS AROUND THE PIPE, AND THAT WILL REMAIN INTACT DURING AND AFTER INSTALLATION OF THE PIPE. IF TAPE OR PAINT IS USED TO STRIPE PIPE DURING INSTALLATION OF THE PIPE, THE TAPE OR PAINT SHALL BE APPLIED IN A CONTINUOUS LINE THAT RUNS PARALLEL TO THE AXIS OF THE PIPE AND THAT IS LOCATED ALONG THE TOP OF THE PIPE. PIPES WITH AN INTERNAL DIAMETER OF 24 INCHES OR GREATER, TAPE OR PAINT SHALL BE APPLIED IN CONTINUOUS LINES ALONG EACH SIDE OF THE PIPE AS WELL AS ALONG THE TOP OF THE PIPE.

FDEP UTILITY SEPARATION REQUIREMENTS:

- (62-555.314, F.A.C. LOCATION OF PUBLIC WATER SYSTEM MAINS)
- FOR THE PURPOSE OF THIS SECTION, THE PHRASE "WATER MAINS" SHALL MEAN MAINS, INCLUDING TREATMENT PLANT PROCESS PIPING, CONVEYING EITHER RAW, PARTIALLY TREATED, OR FINISHED DRINKING WATER; FIRE HYDRANT LEADS; AND SERVICE LINES THAT ARE UNDER THE CONTROL OF A PUBLIC WATER SYSTEM AND THAT HAVE AN INSIDE DIAMETER OF THREE INCHES OR GREATER.
- HORIZONTAL SEPARATION BETWEEN UNDERGROUND WATER MAINS AND SANITARY OR STORM SEWERS, WASTEWATER OR STORMWATER FORCE MAINS, RECLAIMED WATER PIPELINES, AND ON-SITE SEWAGE TREATMENT AND DISPOSAL SYSTEMS.
 - NEW OR RELOCATED, UNDERGROUND WATER MAINS SHALL BE LAID TO PROVIDE A HORIZONTAL DISTANCE OF AT LEAST THREE FEET BETWEEN THE OUTSIDE OF THE WATER MAIN AND THE OUTSIDE OF ANY EXISTING OR PROPOSED STORM SEWER, STORMWATER FORCE MAIN, OR PIPELINE CONVEYING RECLAIMED WATER REGULATED UNDER PART III OF CHAPTER 62-610, F.A.C.
 - NEW OR RELOCATED, UNDERGROUND WATER MAINS SHALL BE LAID TO PROVIDE A HORIZONTAL DISTANCE OF AT LEAST THREE FEET, AND PREFERABLY TEN FEET, BETWEEN THE OUTSIDE OF THE WATER MAIN AND THE OUTSIDE OF ANY EXISTING OR PROPOSED VACUUM-TYPE SANITARY SEWER.
 - NEW OR RELOCATED, UNDERGROUND WATER MAINS SHALL BE LAID TO PROVIDE A HORIZONTAL DISTANCE OF AT LEAST SIX FEET, AND PREFERABLY TEN FEET, BETWEEN THE OUTSIDE OF THE WATER MAIN AND THE OUTSIDE OF ANY EXISTING OR PROPOSED GRAVITY-OR PRESSURE-TYPE SANITARY SEWER, WASTEWATER FORCE MAIN, OR PIPELINE CONVEYING RECLAIMED WATER NOT REGULATED UNDER PART III OF CHAPTER 62-610, F.A.C. THE MINIMUM HORIZONTAL SEPARATION DISTANCE BETWEEN WATER MAINS AND GRAVITY-TYPE SANITARY SEWERS SHALL BE THREE FEET WHERE THE BOTTOM OF THE WATER MAIN IS LAID AT LEAST SIX INCHES ABOVE THE TOP OF THE SEWER.
 - NEW OR RELOCATED, UNDERGROUND WATER MAINS SHALL BE LAID TO PROVIDE A HORIZONTAL DISTANCE OF AT LEAST TEN FEET BETWEEN THE OUTSIDE OF THE WATER MAIN AND ALL PARTS OF ANY EXISTING OR PROPOSED "ON-SITE" SEWAGE TREATMENT AND DISPOSAL SYSTEM" AS DEFINED IN SECTION 381.006(2), F.S., AND RULE 64E-6.002, F.A.C.
 - VERTICAL SEPARATION BETWEEN UNDERGROUND WATER MAINS AND SANITARY OR STORM SEWERS, WASTEWATER OR STORMWATER FORCE MAINS, AND RECLAIMED WATER PIPELINES.
 - NEW OR RELOCATED, UNDERGROUND WATER MAINS CROSSING ANY EXISTING OR PROPOSED GRAVITY-OR VACUUM-TYPE SANITARY SEWER, WASTEWATER FORCE MAIN, OR PIPELINE SHALL BE LAID SO THE WATER MAIN IS AT LEAST SIX INCHES, AND PREFERABLY TEN FEET, ABOVE OR AT LEAST 12 INCHES BELOW THE OUTSIDE OF THE OTHER PIPELINE. HOWEVER, IT IS PREFERABLE TO LAY THE WATER MAIN ABOVE THE OTHER PIPELINE.
 - NEW OR RELOCATED, UNDERGROUND WATER MAINS CROSSING ANY EXISTING OR PROPOSED PRESSURE-TYPE SANITARY SEWER, WASTEWATER FORCE MAIN, OR PIPELINE CONVEYING RECLAIMED WATER SHALL BE LAID SO THE OUTSIDE OF THE WATER MAIN IS AT LEAST 12 INCHES ABOVE OR BELOW THE OUTSIDE OF THE OTHER PIPELINE. HOWEVER, IT IS PREFERABLE TO LAY THE WATER MAIN ABOVE THE OTHER PIPELINE.
 - AT THE UTILITY CROSSINGS DESCRIBED IN PARAGRAPHS (A) AND (B) ABOVE, ONE FULL LENGTH OF WATER MAIN PIPE SHALL BE COVERED ABOVE OR BELOW THE OTHER PIPELINE SO THE WATER MAIN JOINTS WILL BE AS FAR AS POSSIBLE FROM THE OTHER PIPELINE. ALTERNATIVELY, AT SUCH CROSSINGS, THE PIPES SHALL BE ARRANGED SO THAT ALL WATER MAIN JOINTS ARE AT LEAST THREE FEET FROM ALL JOINTS IN VACUUM-TYPE SANITARY SEWERS, STORM SEWERS, STORMWATER FORCE MAINS, OR PIPELINES CONVEYING RECLAIMED WATER REGULATED UNDER PART III OF CHAPTER 62-610, F.A.C., AND AT LEAST SIX FEET FROM ALL JOINTS IN GRAVITY-OR PRESSURE-TYPE SANITARY SEWERS, WASTEWATER FORCE MAINS, OR PIPELINES CONVEYING RECLAIMED WATER NOT REGULATED UNDER PART III OF CHAPTER 62-610, F.A.C.
 - SEPARATION BETWEEN WATER MAINS AND SANITARY OR STORM SEWER MANHOLES.
 - NO WATER MAIN SHALL PASS THROUGH, OR COME INTO CONTACT WITH, ANY PART OF A SANITARY SEWER MANHOLE.
 - EFFECTIVE AUGUST 28, 2003, WATER MAINS SHALL NOT BE CONSTRUCTED OR ALTERED TO PASS THROUGH, OR COME INTO CONTACT WITH, ANY PART OF A STORM SEWER MANHOLE OR INLET STRUCTURE.
 - SEPARATION BETWEEN FIRE HYDRANT DRAINS AND SANITARY OR STORM SEWERS, WASTEWATER OR STORMWATER FORCE MAINS, RECLAIMED WATER PIPELINES, AND ON-SITE SEWAGE TREATMENT AND DISPOSAL SYSTEMS. NEW OR RELOCATED FIRE HYDRANTS WITH UNDERGROUND DRAINS SHALL BE LOCATED SO THAT THE DRAINS ARE AT LEAST THREE FEET FROM ANY EXISTING OR PROPOSED STORM SEWER, STORMWATER FORCE MAIN, OR PIPELINE CONVEYING RECLAIMED WATER REGULATED UNDER PART III OF CHAPTER 62-610, F.A.C.; AT LEAST THREE FEET, AND PREFERABLY TEN FEET, FROM ANY EXISTING OR PROPOSED VACUUM-TYPE SANITARY SEWER; AT LEAST SIX FEET, AND PREFERABLY TEN FEET, FROM ANY EXISTING OR PROPOSED GRAVITY-OR PRESSURE-TYPE SANITARY SEWER, WASTEWATER FORCE MAIN, OR PIPELINE CONVEYING RECLAIMED WATER NOT REGULATED UNDER PART III OF CHAPTER 62-610, F.A.C.; AND AT LEAST TEN FEET FROM ANY EXISTING OR PROPOSED "ON-SITE" SEWAGE TREATMENT AND DISPOSAL SYSTEM" AS DEFINED IN SECTION 381.006(2), F.S., AND RULE 64E-6.002, F.A.C.

LOCATION OF PUBLIC WATER SYSTEM MAINS IN ACCORDANCE WITH F.A.C. RULE 62-555.314

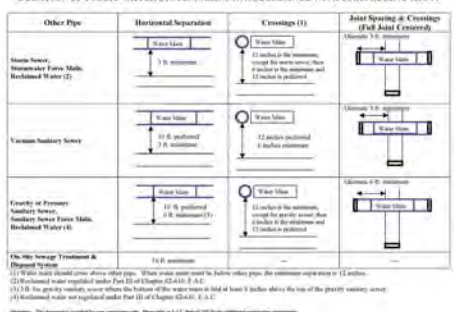

SCALE	N.T.S.	PROJECT	CED-003	SHEET	C4.0
DRAWN BY	G. SANDHEZ	DESIGNED BY	L. CLASSON	CHECKED BY	L. CLASSON
DATE	1/24/2017	BAS ENGINEERING CONSULTANTS, LLC DBA APPLAN ENGINEERING, LLC 2221 LEFF ROAD, SUITE 17 WINTER PARK, FLORIDA 32789 (407) 960-5866			
UTILITY NOTES NORTHERN OAKS SUBDIVISION CITY OF WINTER SPRINGS, FLORIDA					
BOARD OF PROFESSIONAL ENGINEERING CERTIFICATE NO. 28973					

P:\PROJECT DRAWINGS\CED-003 - Northern Oaks Subdivision\05 Final Engineering\Plan\Utility_Plan.dwg Modified: 2/24/2017 By: aschsch

LEGEND

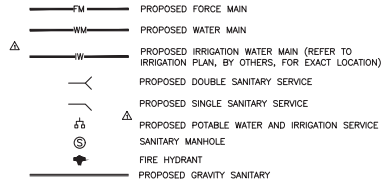

FIRE HYDRANT NOTES:

- FIRE HYDRANT LOCATION AND DISTRIBUTION SHALL FOLLOW NFPA 1, APPENDIX I.
- HYDRANTS SHALL BE PROVIDED WITH A CLEAR DISTANCE OF 7.5 FT IN FRONT AND THE SIDES; WITH A 4 FT CLEARANCE TO THE REAR OF THE HYDRANT. (NFPA 1, 18.3.4.1)
- AFTER THE INSTALLATION OF THE NEW HYDRANTS, A FIRE FLOW TESTING SHALL BE PERFORMED IN ACCORDANCE WITH NFPA 291, RECOMMENDED PRACTICE FOR FIRE FLOW TESTING AND MARKING OF HYDRANTS; A FIRE FLOW TEST RESULTS FROM THE NEAREST EXISTING HYDRANT THAT HAS BEEN WITNESSED BY A UTILITIES INSPECTOR WILL NEED TO BE PROVIDED. DOCUMENTATION FOR FIRE FLOW TESTING SHALL INCLUDE A FIRE FLOW TEST REPORT AND A HYDRAULIC GRAPH. (SCPSTM, FIRE FLOW TESTING PROCEDURE)

FIRE DEPARTMENT NOTES:

- FIRE DEPARTMENT ACCESS ROADS SHALL BE PROVIDED AT THE START OF A PROJECT AND SHALL BE MAINTAINED THROUGHOUT CONSTRUCTION.
- WHERE UNDERGROUND WATER MAINS AND HYDRANTS ARE TO BE PROVIDED, THEY SHALL BE INSTALLED, COMPLETED, AND IN SERVICE PRIOR TO CONSTRUCTION WORK (NFPA 1, SECTION 16.4.3.1).
- NEW FIRE HYDRANTS MUST BE TESTED AFTER INSTALLATION. THE DEVELOPER SHALL DEMONSTRATE SATISFACTORY TEST RESULTS PRIOR TO FINAL INSPECTION OF THE UTILITY SYSTEM OR THE CERTIFICATE OF OCCUPANCY, WHICHEVER COMES FIRST (NFPA 1, SECTION 18.3).
- A WATER SUPPLY FOR FIRE PROTECTION, EITHER TEMPORARY OR PERMANENT, SHALL BE MADE AVAILABLE AS SOON AS COMBUSTIBLE MATERIAL ACCUMULATES. THIS APPLIES TO BOTH COMMERCIAL AND RESIDENTIAL DEVELOPMENTS. (NFPA 16.4.3.1)

UTILITY NOTES:

- ALL WATER MAINS LEADING TO A PROPOSED FIRE HYDRANT SHALL BE A MINIMUM OF 8".
- FIRE FLOW REQUIREMENTS FOR BUILDINGS SHALL BE IN ACCORDANCE WITH NFPA 1, SECTION 18.4.
- DOCUMENTATION FOR FIRE FLOW TESTING SHALL INCLUDE A FIRE FLOW REPORT AND A HYDRAULIC GRAPH.
- CONTRACTOR SHALL BE RESPONSIBLE FOR DEFLECTING WATER MAIN WHEN 12 INCHES (MIN.) OF SEPARATION IS NOT ACHIEVABLE TO THE FDEP UTILITY SEPARATION REQUIREMENTS AND STANDARD UTILITY CROSSING. REFER TO UTILITY NOTES SHEET FOR SEPARATION REQUIREMENTS.
- ALL OFF-SITE PORTIONS OF THE SANITARY SYSTEM SHALL BE INSTALLED WITH A MINIMUM COMPACTION OF 98% OF THE MAXIMUM DENSITY AS PER AASHTO T-180.
- ALL GRAVITY MAINS SHALL BE SDR-35 PIPE.
- ALL WATER MAINS SHALL BE C-900 DR-18 PVC PIPE.
- ALL FORCE MAINS SHALL BE DR-11 PIPE.
- ALL UTILITY IMPROVEMENTS SHALL BE PUBLICALLY OWNED AND MAINTAINED.
- A BLANKET UTILITY EASEMENT OVER ALL PROPOSED UTILITY IMPROVEMENTS SHALL BE DEDICATED TO CITY OF WINTER SPRINGS WITH THE PLAT OF THIS PROPERTY.

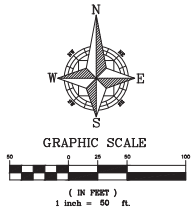

NO.	DATE	DESCRIPTION
1	1/24/2017	ISSUED FOR PERMITS
2	1/24/2017	ISSUED FOR PERMITS
3	1/24/2017	ISSUED FOR PERMITS
4	1/24/2017	ISSUED FOR PERMITS
5	1/24/2017	ISSUED FOR PERMITS
6	1/24/2017	ISSUED FOR PERMITS
7	1/24/2017	ISSUED FOR PERMITS
8	1/24/2017	ISSUED FOR PERMITS
9	1/24/2017	ISSUED FOR PERMITS
10	1/24/2017	ISSUED FOR PERMITS
11	1/24/2017	ISSUED FOR PERMITS
12	1/24/2017	ISSUED FOR PERMITS
13	1/24/2017	ISSUED FOR PERMITS
14	1/24/2017	ISSUED FOR PERMITS
15	1/24/2017	ISSUED FOR PERMITS
16	1/24/2017	ISSUED FOR PERMITS
17	1/24/2017	ISSUED FOR PERMITS
18	1/24/2017	ISSUED FOR PERMITS
19	1/24/2017	ISSUED FOR PERMITS
20	1/24/2017	ISSUED FOR PERMITS
21	1/24/2017	ISSUED FOR PERMITS
22	1/24/2017	ISSUED FOR PERMITS
23	1/24/2017	ISSUED FOR PERMITS
24	1/24/2017	ISSUED FOR PERMITS
25	1/24/2017	ISSUED FOR PERMITS
26	1/24/2017	ISSUED FOR PERMITS
27	1/24/2017	ISSUED FOR PERMITS
28	1/24/2017	ISSUED FOR PERMITS
29	1/24/2017	ISSUED FOR PERMITS
30	1/24/2017	ISSUED FOR PERMITS
31	1/24/2017	ISSUED FOR PERMITS
32	1/24/2017	ISSUED FOR PERMITS
33	1/24/2017	ISSUED FOR PERMITS
34	1/24/2017	ISSUED FOR PERMITS
35	1/24/2017	ISSUED FOR PERMITS
36	1/24/2017	ISSUED FOR PERMITS
37	1/24/2017	ISSUED FOR PERMITS
38	1/24/2017	ISSUED FOR PERMITS
39	1/24/2017	ISSUED FOR PERMITS
40	1/24/2017	ISSUED FOR PERMITS
41	1/24/2017	ISSUED FOR PERMITS
42	1/24/2017	ISSUED FOR PERMITS
43	1/24/2017	ISSUED FOR PERMITS
44	1/24/2017	ISSUED FOR PERMITS
45	1/24/2017	ISSUED FOR PERMITS
46	1/24/2017	ISSUED FOR PERMITS
47	1/24/2017	ISSUED FOR PERMITS
48	1/24/2017	ISSUED FOR PERMITS
49	1/24/2017	ISSUED FOR PERMITS
50	1/24/2017	ISSUED FOR PERMITS

B&S ENGINEERING CONSULTANTS, LLC DBA
APIAN ENGINEERING, LLC
 2221 LEE ROAD, SUITE 17
 WINTER PARK, FLORIDA 32789
 (407) 960-5868

UTILITY PLAN
 NORTHERN OAKS SUBDIVISION
 CITY OF WINTER SPRINGS, FLORIDA

SCALE: 1" = 50'
 PROJECT: CED-003
 SHEET: C4.1
 DRAWN: G. SANDHEZ
 DESIGNED: L. GLASSON
 CHECKED: L. GLASSON
 DATE: 1/24/2017
 BOARD OF PROFESSIONAL ENGINEERING CERTIFICATE NO. 28973

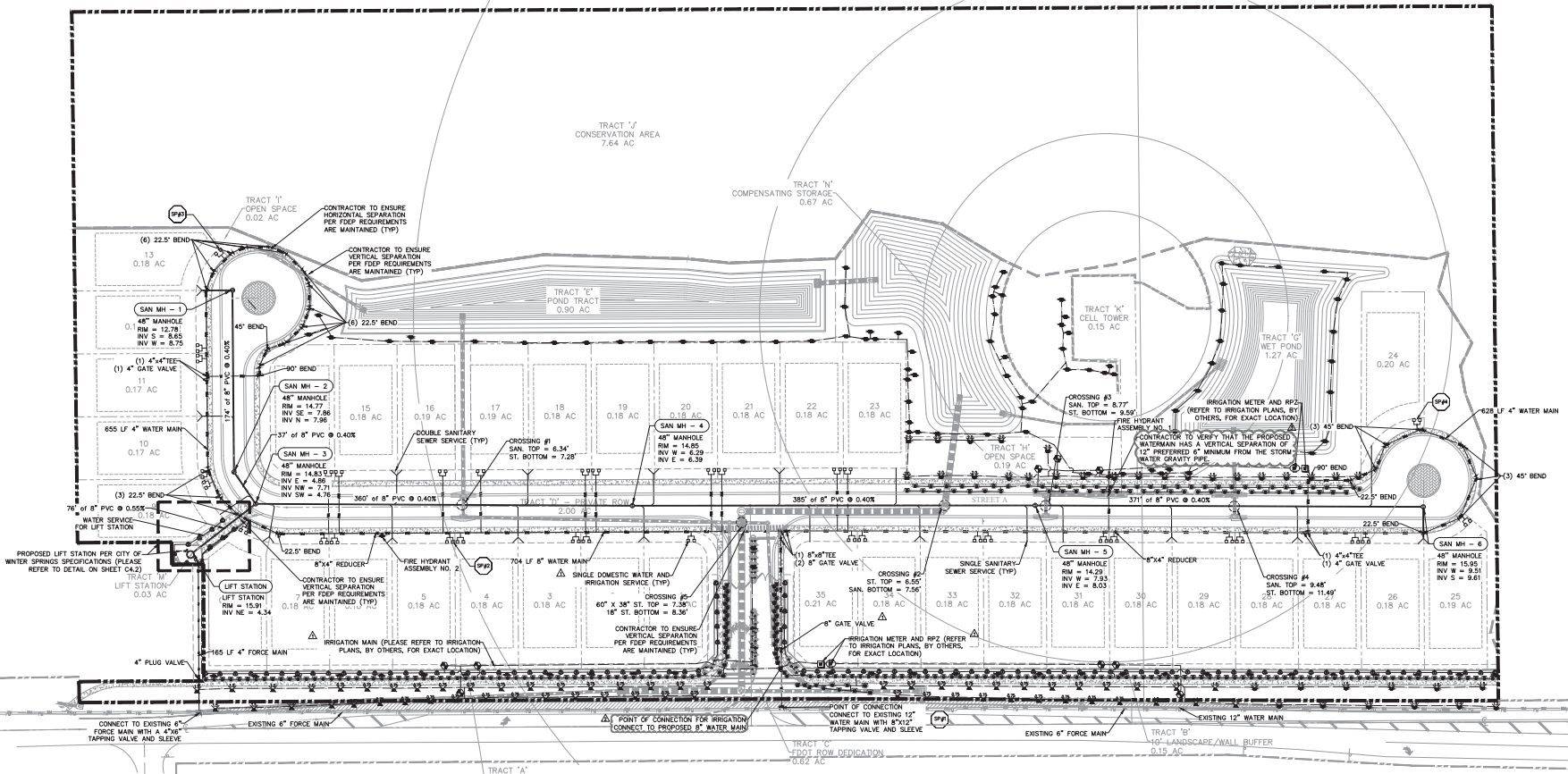

48 HOURS BEFORE DIGGING
CALL
 811 or 1-800-432-4770
 RUN-RIE STATE ONE CALL CENTER

P:\PROJECT DRAWINGS\CED-003 - Northern Oaks Subdivision\5.9 Drawings\5.9a\WSP\WSP\WSP Lift Station Details.dwg Modified: 2/14/2017 By: sponner

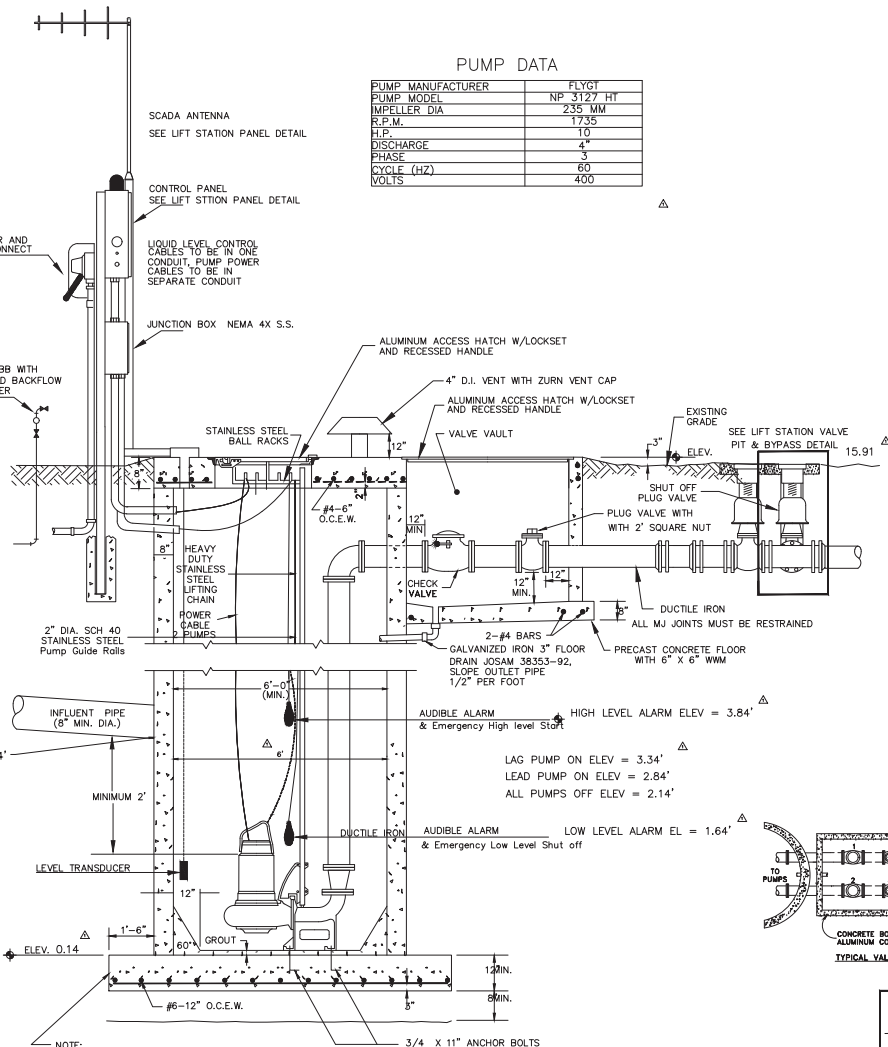

NOTE: CONTRACTOR TO PROVIDE SEALS IN CONDUIT BETWEEN THE LIFT STATION AND CONTROL PANEL PER CITY OF WINTER SPRINGS.

Item No.	Description	QTY
01	Single SR1 - 307 Antenna	1
02	3" X 1/2" Aluminum or Galvanized Bell Reducer	1
03	1" Dia. X 5'-0" SC H 40 Aluminum or Galvanized Pipe with Cap	1
04	Hydra Cable	1
05	Plastic Tie Wraps	As Req.
06	1" Dia X 5' SC H 40 Aluminum or Galvanized Pipe filled with Concrete	As Req.
07	1" X 1/2" Minimum Mounting Block	As Req.
08	3" Galvanized Iron SC H 80 Pipe with Caps	2
09	Grounding Rods	As Req.
10	Lift Station Control Panel	1
11	Emergency Power Receptacle	1
12	High Level Alarm one Lead	1
13	30" H X 24" W SCADA RTU NEMA Type 1R Enclosure	1
14	Junction Box NEMA 4X S.S.	1
15	Power Disconnect	1
16	Meng Base	1
17	12" Dia. X 30" Deep Poured Concrete Base	1
18	12" X 24" Deep Poured Concrete Base	2

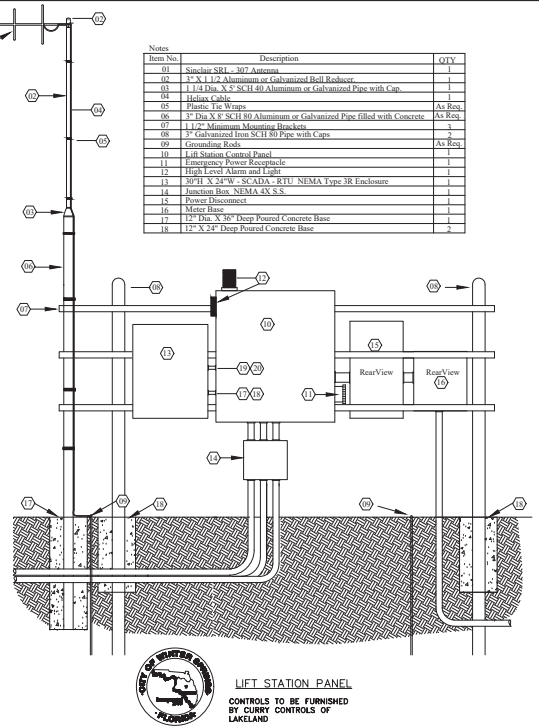

LIFT STATION PANEL
CONTROLS TO BE FURNISHED BY CURRY CONTROLS OF LAKELAND

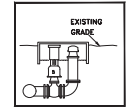
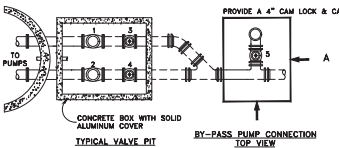
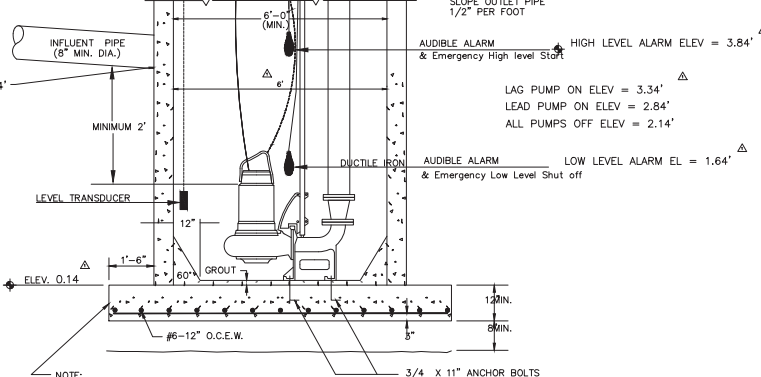

- NOTES:
- 1 & 2 ARE CHECK VALVES
 - 3, 4, & 5 ARE PLUG VALVES
 - VALVE BOX SHALL BE INSTALLED AND ADJUSTED AT GRADE AND SHALL HAVE CONCRETE COLLAR 18" X 18" X 4" REBAR
 - MJ JOINTS ARE TO BE RESTRAINED WITH GRIP RING OR NEG A LIG RESTRAINTS

LIFT STATION VALVE PIT & BYPASS

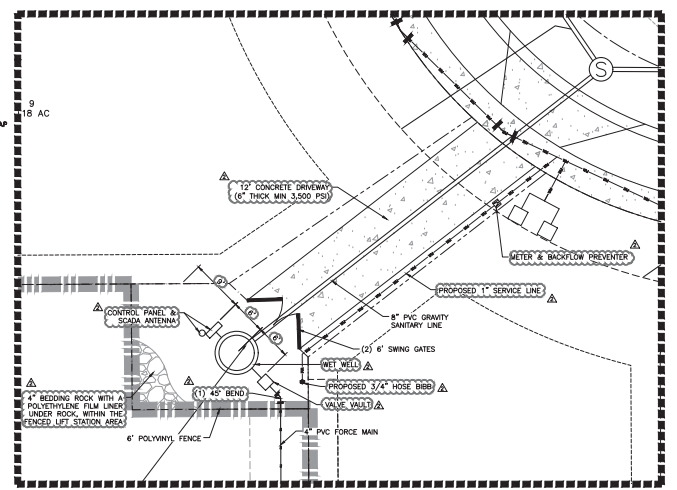

TRACT 'M'
LIFT STATION TRACT DETAIL
1"=10'



LIFT STATION DETAIL



SCALE	N.T.S.	PROJECT	CEP-003	SHEET	C4.2
DRAWN	G. SANDHEZ	DESIGNED	L. GLASSON	CHECKED	L. GLASSON
DATE	1/24/2017	BOARD OF PROFESSIONAL ENGINEERING CERTIFICATE NO. 28973			
BAS ENGINEERING CONSULTANTS, LLC DBA APPIAN ENGINEERING, LLC 2221 LEE ROAD, SUITE 17 WINTER PARK, FLORIDA 32789 (407) 960-5868					
CITY OF WINTER SPRINGS LIFT STATION DETAILS NORTHERN OAKS SUBDIVISION CITY OF WINTER SPRINGS, FLORIDA					
DATE	REV	DESCRIPTION			

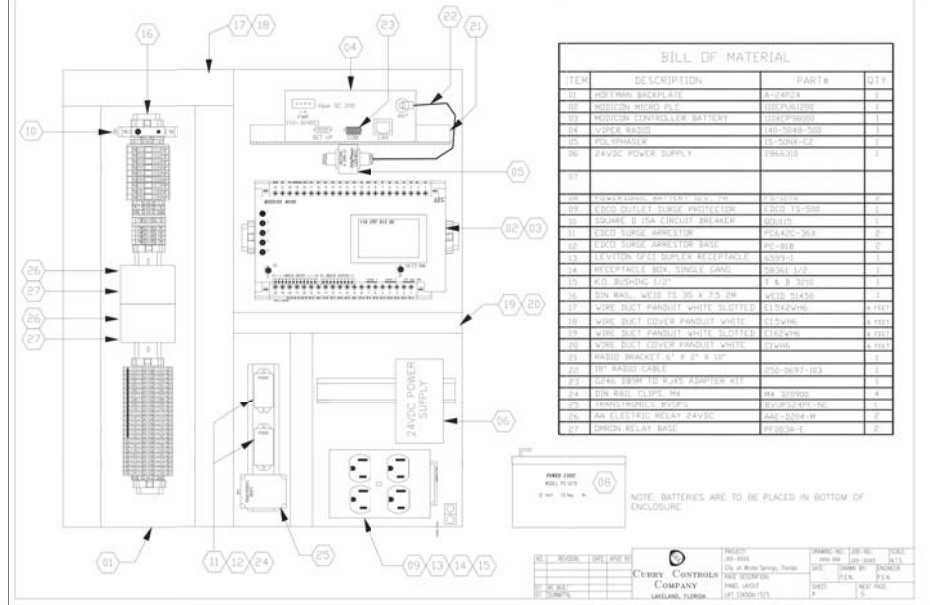
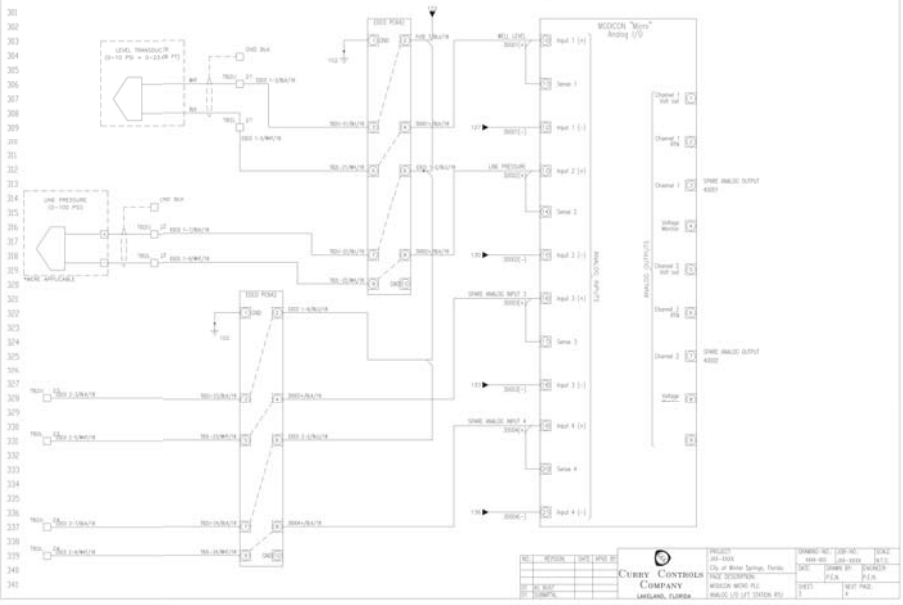
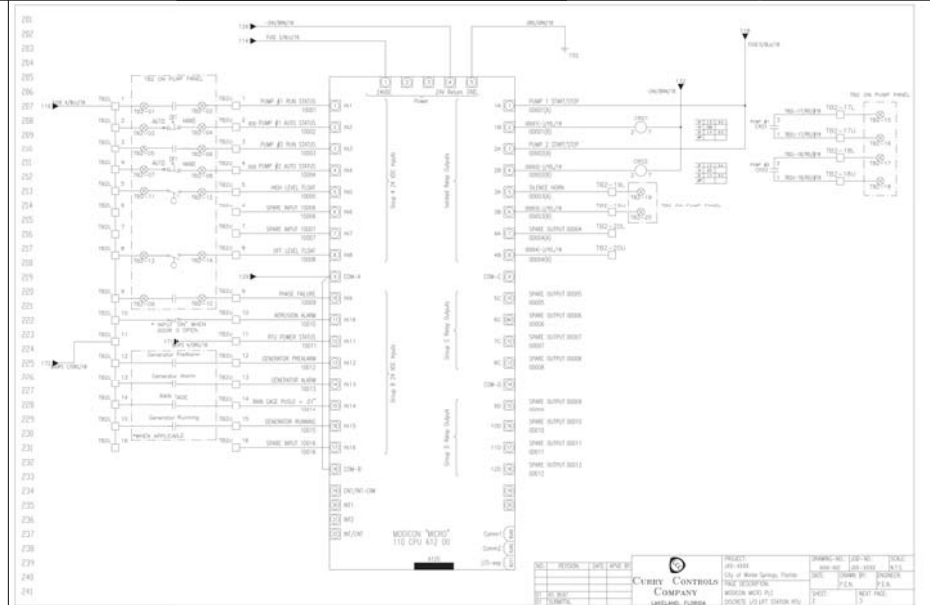
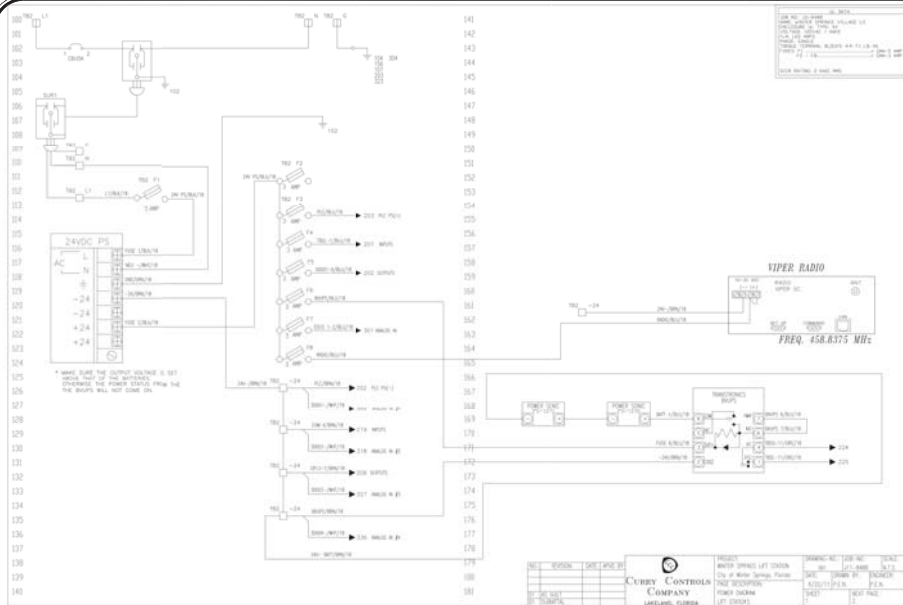

CONTRACTOR TO CONTACT CURRY CONTROLS OF LAKELAND FOR LIFT STATION CONTROL PANEL DETAILS. SCOTT CYPHERT: (863) 646-5731

SCALE	N.T.S.	PROJECT	CEP-003	SHEET	C4.3
DRAWN	G. SANDEZ	DESIGNED	L. CLASSON	CHECKED	L. CLASSON
DATE	1/24/2017				
BOARD OF PROFESSIONAL ENGINEERING CERTIFICATE NO. 28973					
LIFT STATION CONTROL PANEL DETAILS					
NORTHERN OAKS SUBDIVISION CITY OF WINTER SPRINGS, FLORIDA					
B&S ENGINEERING CONSULTANTS, LLC DBA APPIAN ENGINEERING, LLC 2221 LEF FLORE, SUITE 17 WINTER PARK, FLORIDA 32789 (407) 960-5868					
DATE		DATE		DATE	
BY		BY		BY	
DESCRIPTION		DESCRIPTION		DESCRIPTION	

P:\PROJECT DRAWINGS\CED-003 - Northern Oaks Subdivision S.P. Drawings\Sheet\Proposed Final Engineering Plan\Printing & Grading Plan.dwg Modified: 2/24/2017 By: sponoch

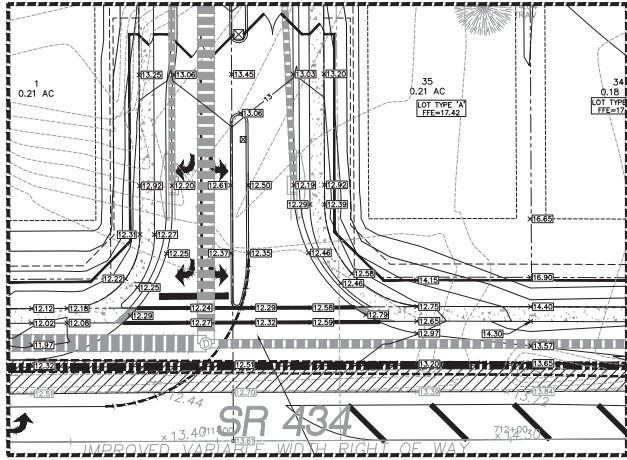

PROPOSED ENTRANCE DETAIL
1" = 20'

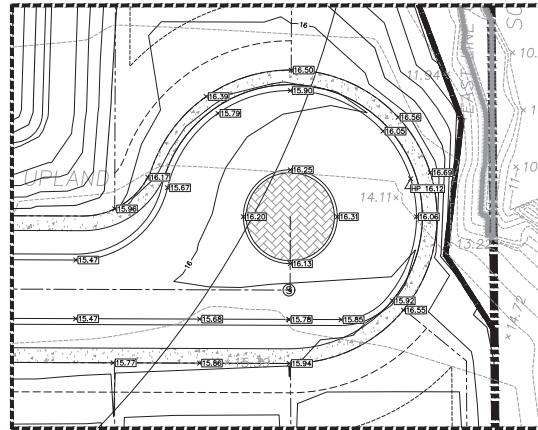

STREET 'A' EAST CUL-DE-SAC DETAIL
1" = 20'

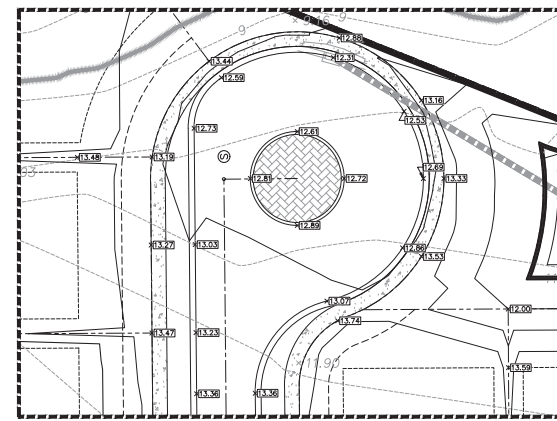

STREET 'A' WEST CUL-DE-SAC DETAIL
1" = 20'

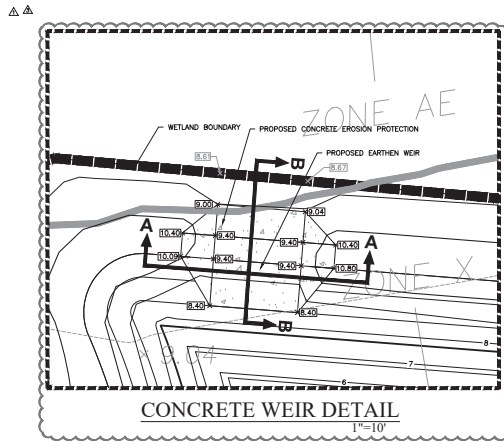

CONCRETE WEIR DETAIL
1" = 10'

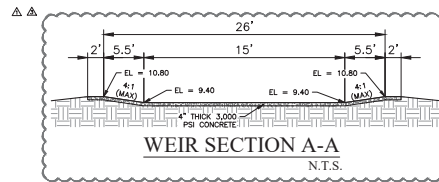

WEIR SECTION A-A
N.T.S.

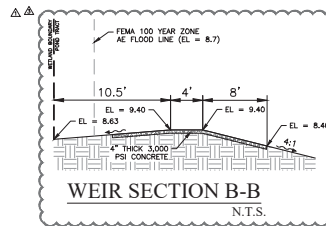

WEIR SECTION B-B
N.T.S.



DRAWN: O. SANDOZ		DESIGNED: L. GLASSON		CHECKED: L. GLASSON		DATE: 1/24/2017	
SCALE: N.T.S.	PROJECT: CED-003	DRAWING TITLE: PAVING & GRADING PLAN				SHEET: C5.1	
BOARD OF PROFESSIONAL ENGINEERING CERTIFICATE NO. 28973				NORTHERN OAKS SUBDIVISION CITY OF WINTER SPRINGS, FLORIDA			
BAS ENGINEERING CONSULTANTS, LLC DBA APPIAN ENGINEERING, LLC				2221 LEE ROAD, SUITE 17 WINTER PARK, FLORIDA 32789 (407) 960-5868			
CASE: A 02/26/17 EXHIBIT COMMENTS APPLICATION NO. 44397-17 01/26/17 03/27/17		CASE: A 02/26/17 EXHIBIT COMMENTS APPLICATION NO. 44397-17 01/26/17 03/27/17		CASE: A 12/27/16 CITY OF WINTER SPRINGS (DP2016-0000003) COMMENTS 12/23/16		DATE: 1/24/2017	
DESCRIPTION:		DESCRIPTION:		DESCRIPTION:		DESCRIPTION:	
BY:	BY:	BY:	BY:	BY:	BY:	BY:	BY:

48 HOURS BEFORE DIGGING
CALL
VOL. PERM
811 or 1-800-432-4770
RUN-RISE STATE ONE CALL CENTER

P:\PROJECT DRAWINGS\CED-003 - Northern Oaks Subdivision\SR Drawings\SR\Layout\05 Final Engineering Plan\Plan & Profile.dwg Modified: 2/24/2017 By: asanchez

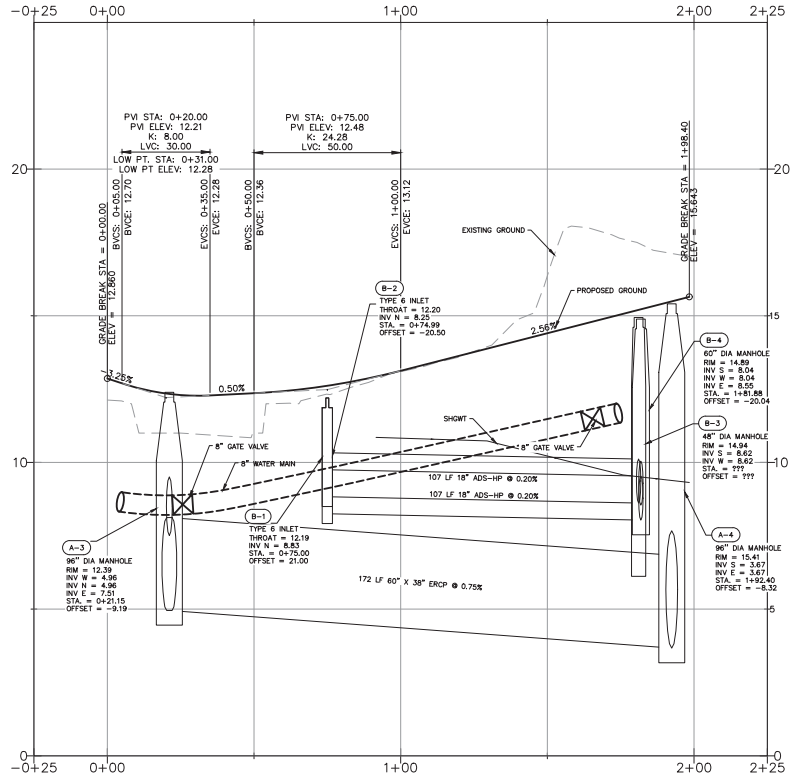
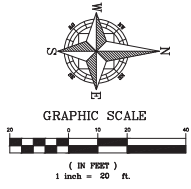
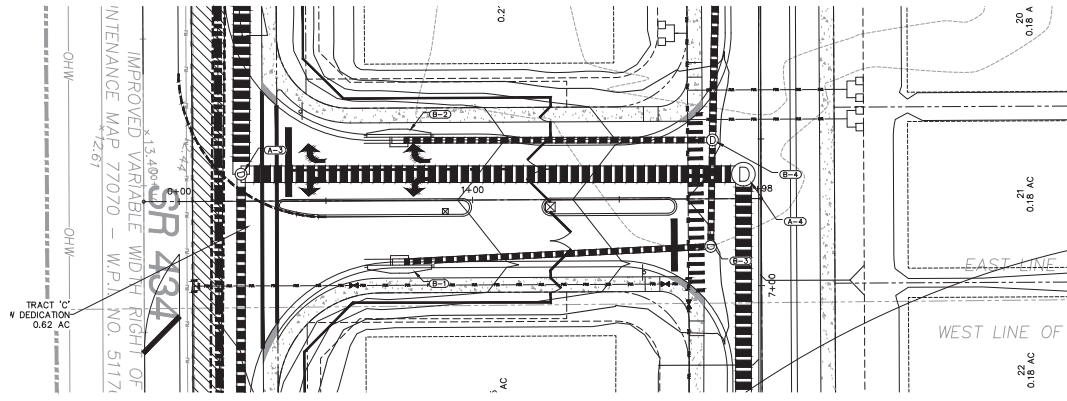

VERTICAL SCALE: 1" = 2'
HORIZONTAL SCALE: 1" = 20'



SCALE	1" = 20'	DRAWN BY	O. SANDHEZ	PROJECT	PLAN & PROFILE - STREET 'B' STA. 0+00 - STA. 1+98
PROJECT	CED-003	DESIGNED BY	L. CLASSON	CHECKED BY	L. CLASSON
SHEET	C6.0	DATE	1/24/2017	DESCRIPTION	NORTHERN OAKS SUBDIVISION CITY OF WINTER SPRINGS, FLORIDA
DATE		DATE		DATE	
REV		DATE		DESCRIPTION	
BOARD OF PROFESSIONAL ENGINEERING CERTIFICATE NO. 28973 BAS ENGINEERING CONSULTANTS, LLC DBA APPIAN ENGINEERING, LLC 2221 LEE ROAD, SUITE 17 WINTER PARK, FLORIDA 32789 (407) 960-5868					

P:\PROJECT DRAWINGS\CED-003 - Northern Oaks Subdivision S.P. Drawings\Sheet\Vertical\05 Final Engineering Plan\Plan & Profile.dwg Modified: 2/24/2017 By: asanchez

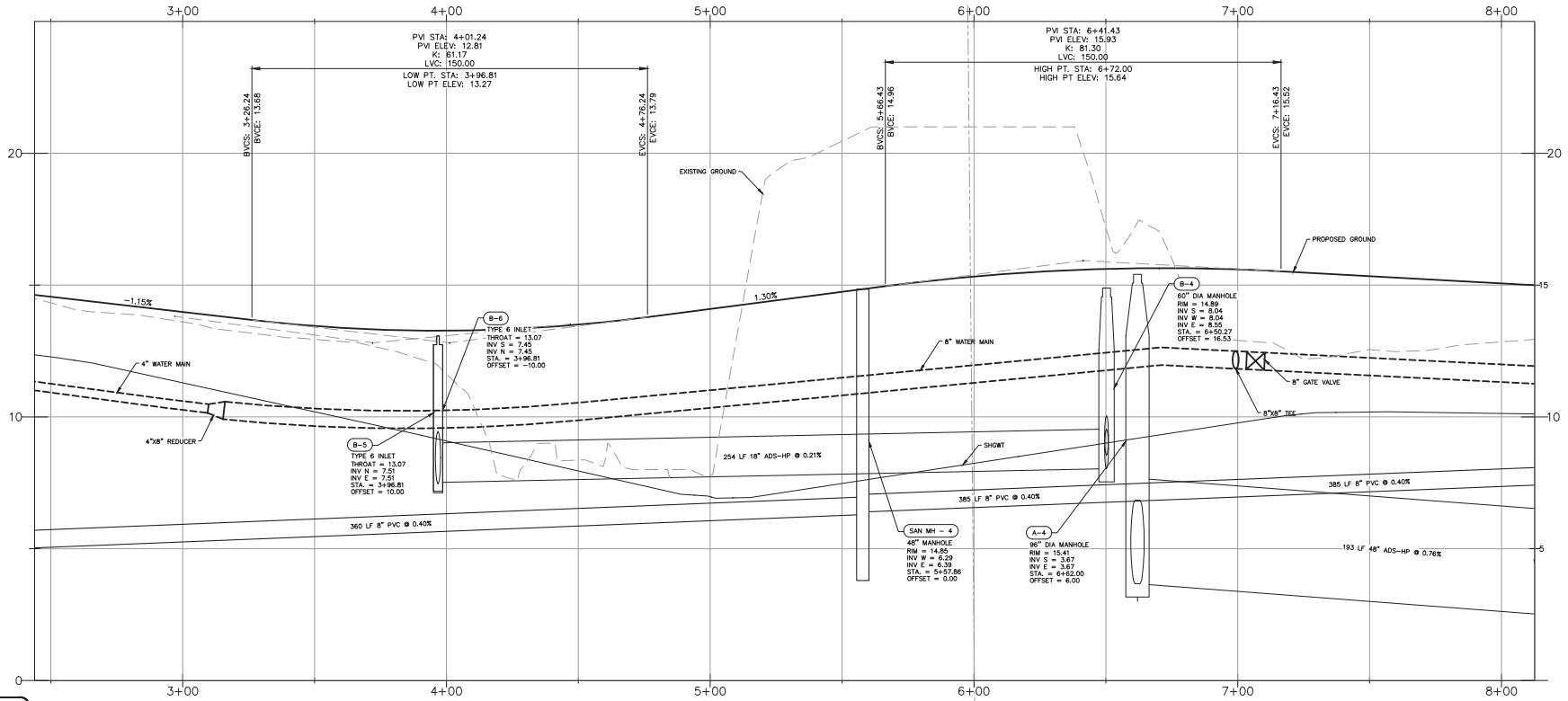
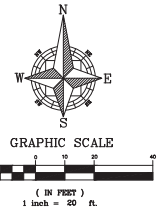
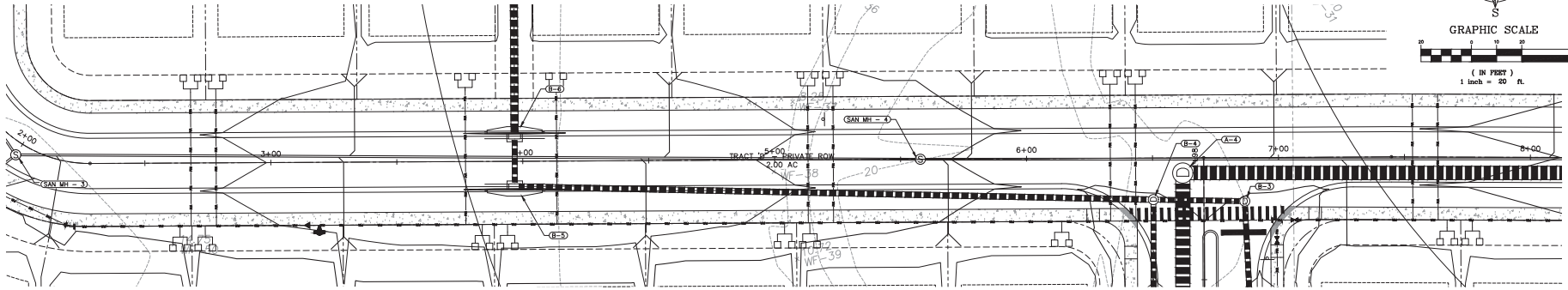

VERTICAL SCALE: 1" = 2'
HORIZONTAL SCALE: 1" = 20'

48 HOURS BEFORE DIGGING
CALL TOLL FREE
811 or 1-800-432-4770
FLORIDA STATE ONE CALL CENTER

SCALE	1" = 20'	DRAWN	O. SANCHEZ	PROJECT	2221 LEE ROAD, SUITE 17 WINTER PARK, FLORIDA 32789
PROJECT	CED-003	DESIGNED	L. CLASSON	CHECKED	L. CLASSON
SHEET	C6.2	DATE	1/24/2017	NORTHERN OAKS SUBDIVISION CITY OF WINTER SPRINGS, FLORIDA	
BOARD OF PROFESSIONAL ENGINEERING CERTIFICATE NO. 28973				BAS ENGINEERING CONSULTANTS, LLC DBA APPIAN ENGINEERING, LLC 2221 LEE ROAD, SUITE 17 WINTER PARK, FLORIDA 32789 (407) 960-5868	

P:\PROJECT DRAWINGS\CED-003 - Northern Oaks Subdivision\SP Drawings\Vertical\Profile & Plan\Profile.dwg Modified: 2/28/2017 By: sanchiez

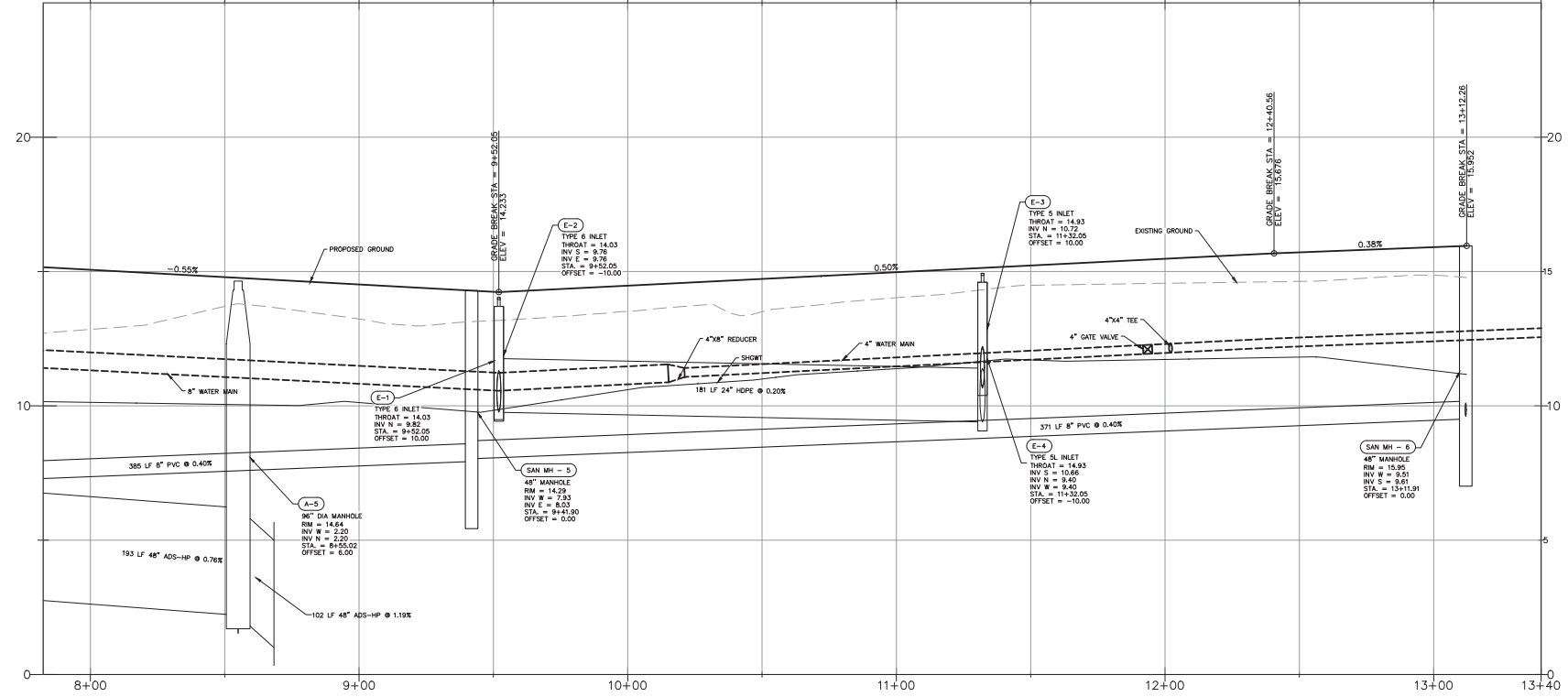
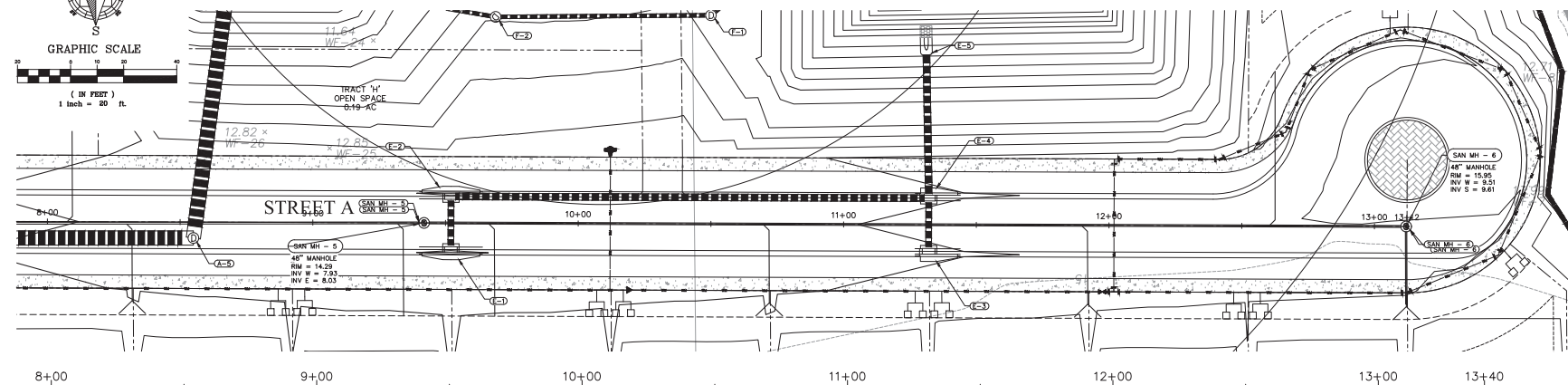
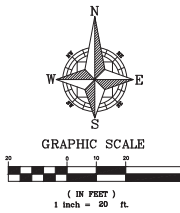

VERTICAL SCALE: 1" = 2'
 HORIZONTAL SCALE: 1" = 20'

48 HOURS BEFORE DIGGING
CALL
 TEL: 811
 811 or 1-800-432-4770
 SUNSHINE STATE ONE CALL CENTER

SCALE	1" = 20'
PROJECT	CED-003
SHEET	C6.3
DATE	1/24/2017
DRAWN BY	O. SANDOZ
DESIGNED BY	L. CLASSON
CHECKED BY	L. CLASSON
DATE	1/24/2017
DESCRIPTION	PLAN & PROFILE - STREET 'A' STA. 8+00 - STA. 13+12 NORTHERN OAKS SUBDIVISION CITY OF WINTER SPRINGS, FLORIDA
DATE	
BY	

BAS ENGINEERING CONSULTANTS, LLC DBA
APPIAN ENGINEERING, LLC
 2221 LEE ROAD, SUITE 17
 WINTER PARK, FLORIDA 32789
 (407) 960-5868

DATE		DESCRIPTION
12/27/16	A	12.27.16 CITY OF WINTER SPRINGS (2024-0000003) COMMENTS 12.23.16
02/08/17	A	02/08/17 DESIGN COMMENTS APPLICATION NO. 143527-17 02/08/17

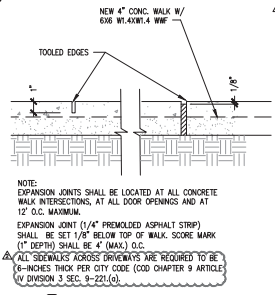

1 CONCRETE WALK / RECREATIONAL PATH
N.T.S.

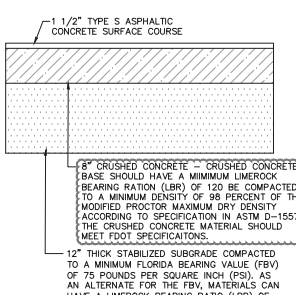

2 TYPICAL PAVEMENT SECTION
N.T.S.

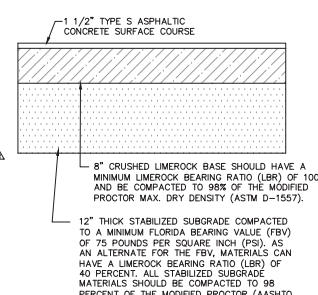

3 OPTIONAL LIMEROCK PAVEMENT SECTION
N.T.S.

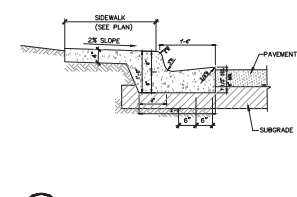

4 MONOLITHIC CURB AND SIDEWALK
(REFER TO F.O.D.T. INDEX 515)
N.T.S.

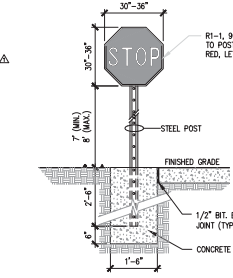

5 STOP SIGN
N.T.S.

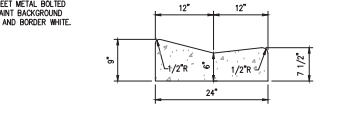

6 MIAMI CURB & GUTTER
N.T.S.

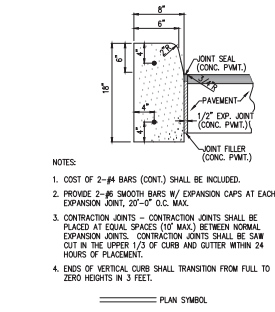

7 TYPE "D" CURB
(REFER TO F.O.D.T. INDEX 300) N.T.S.

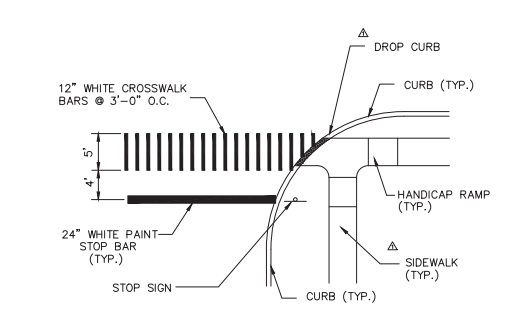

8 INTERNAL CROSSWALK / STOP BAR DETAIL
N.T.S.

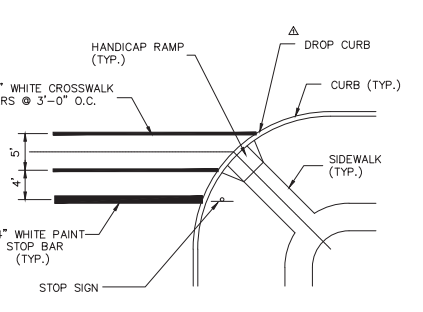

9 OFFSITE CROSSWALK PER FDOT STANDARD INDEX 17346
N.T.S.

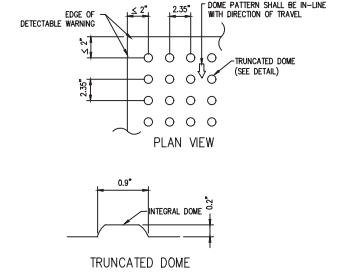

10 DETECTABLE WARNING
N.T.S.

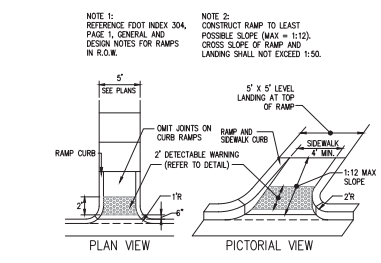

11 HANDICAP END RAMP
3000 PSI (MIN) CONCRETE N.T.S.

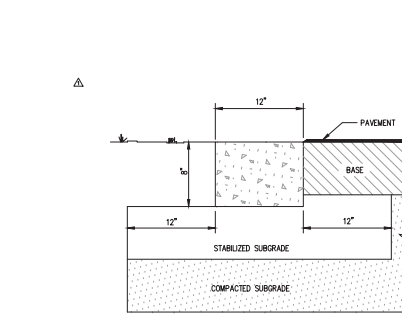

12 RIBBON CURB
3000 PSI (MIN) N.T.S.

- NOTES
- CONSTRUCTION JOINTS SHALL BE PLACED AT EQUAL SPACES (10' MAX) BETWEEN NORMAL EXPANSION JOINTS. CONSTRUCTION JOINTS SHALL BE SAW CUT WITHIN 24 HRS. OF PLACEMENT.
 - FOR CURB & GUTTER CONSTRUCTED ADJACENT TO CONCRETE PAVEMENT, 1/2" EXPANSION JOINT MATERIALS SHALL BE PLACED BETWEEN THE EDGE OF GUTTER AND EDGE OF PAVEMENT.

- NOTE:
- CURB RAMP RUNNING SLOPES SHALL NOT BE STEEPER THAN 1:12 AND CROSS SLOPE SHALL BE 0.02 OR FLATTER.
 - DETECTABLE WARNING SURFACES SHALL BE CONSTRUCTED BY TEXTURING OR APPLYING A TRUNCATED DOME MATERIAL IN CONFORMANCE WITH THE U.S. DEPARTMENT OF JUSTICE ADA STANDARDS FOR ACCESSIBLE DESIGN. ADA ACCESSIBILITY GUIDELINES SECTION 402.2 TRANSITION SLOPES ARE NOT TO HAVE DETECTABLE WARNINGS.
 - WHERE A CURB RAMP IS CONSTRUCTED WITHIN AN EXISTING CURB, CURB AND GUTTER SHALL BE REMOVED TO THE NEAREST JOINT BEYOND THE CURB TRANSITIONS OR TO THE EXTENT THAT NO REMAINING SECTION OF CURB OR GUTTER IS LESS THAN 5' LONG. THE EXISTING SIDEWALK SHALL BE REMOVED TO THE NEAREST JOINT BEYOND THE TRANSITION SLOPE WALK AROUND OR TO THE EXTENT THAT NO REMAINING SECTION OF SIDEWALK IS LESS THAN 5'.
 - WHERE ADJACENT WALKING SURFACES ARE COLORED OR ARE CONSTRUCTED WITH MATERIALS OTHER THAN STANDARD CLASS 1 PORTLAND CEMENT CONCRETE IN ACCORDANCE WITH SECTION 522 OF THE SPECIFICATIONS, THE PLAN MUST PROVIDE FOR DETECTABLE WARNING SURFACE COLORS OR MATERIALS THAT PROVIDE THE NECESSARY CONTRAST, EITHER DARK-ON-LIGHT OR LIGHT-ON-DARK. (SAFETY YELLOW OR BRICK RED)
 - RECOMMENDED MANUFACTURER: ENGINEERED PLASTICS, INC. (FORMER TLE) OLIVIA TOWNS, 300 PEARL STREET, SUITE 200, BUFFALO, NY 14202. PHONE: (800) 682-2525

SCALE	N.T.S.	PROJECT	CE0-003	SHEET	C7.0
DRAWN	G. SANDOZ	DESIGNED	L. GLASSON	CHECKED	L. GLASSON
DATE	1/24/2017	NORTHERN OAKS SUBDIVISION CITY OF WINTER SPRINGS, FLORIDA			
BOARD OF PROFESSIONAL ENGINEERING CERTIFICATE NO. 28973					
BAS ENGINEERING CONSULTANTS, LLC DBA APPIAN ENGINEERING, LLC 2221 LEE ROAD, SUITE 17 WINTER PARK, FLORIDA 32789 (407) 960-5868					

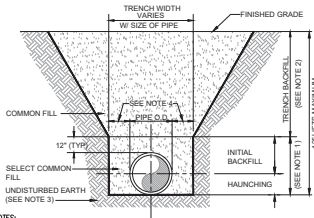

- NOTES:**
- INITIAL BACKFILL AND HAUNCHING: SELECT COMMON FILL COMPACTED TO 95% (98% UNDER PAVEMENT) OF THE MAXIMUM DENSITY AS PER AASHTO T-180.
 - TRENCH BACKFILL: COMMON FILL COMPACTED TO 95% (98% UNDER PAVEMENT) OF THE MAXIMUM DENSITY AS PER AASHTO T-180.
 - PIPE BEDDING SHALL BE COMPACTED TO 95% (MIN) OF THE MODIFIED PROCTOR MAXIMUM DRY DENSITY. BEDDING ROCK CAN BE USED FOR BEDDING IF SUBGRADE SOILS ARE TOO WET TO COMPACT, OR AS DIRECTED BY THE ENGINEER.
 - 1 1/2" MAX. (1 1/2" MIN.) FOR PIPE DIAMETER LESS THAN 24" AND 24" MAX. (12" MIN.) FOR PIPE DIAMETER 24" AND LARGER.
 - WATER SHALL NOT BE PERMITTED IN THE TRENCH DURING CONSTRUCTION.
 - ALL PIPE TO BE INSTALLED WITH BELL FACING UPSTREAM TO THE DIRECTION OF THE FLOW.
 - FINAL RESTORATION IN IMPROVED AREAS SHALL BE IN COMPLIANCE WITH ALL APPLICABLE REGULATIONS OF GOVERNING AGENCIES.

1 TRENCH DETAIL
N.T.S.

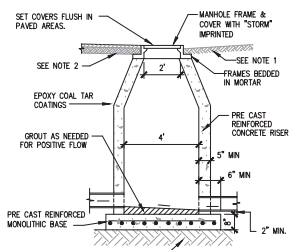

- NOTES:**
- IN UNPAVED AREAS TOP OF FRAME SHALL BE 2" ABOVE FINISHED GRADE
 - ALL IMPAVEMENT STRUCTURES MUST CONFORM TO H20 LOADING STANDARDS
 - 12 INCHES OF STONE BEDDING (FOOT #7 STONE, NON-CALCAREOUS) CAN BE USED FOR BEDDING IF SUBGRADE SOILS ARE TOO WET TO COMPACT.

2 MANHOLE
N.T.S.

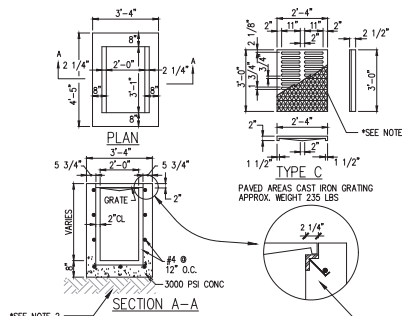

- NOTES:**
- FOR PEDESTRIAN AND VEHICULAR USE, USE CAST IRON GRATE FOR NON VEHICULAR USE, USE STEEL GRATE.
 - SUBGRADE SHALL BE COMPACTED TO 95% (98% UNDER PAVEMENT) OF THE MODIFIED PROCTOR MAXIMUM DRY DENSITY.

3 TYPE "C" INLET
N.T.S.

4 NOT USED

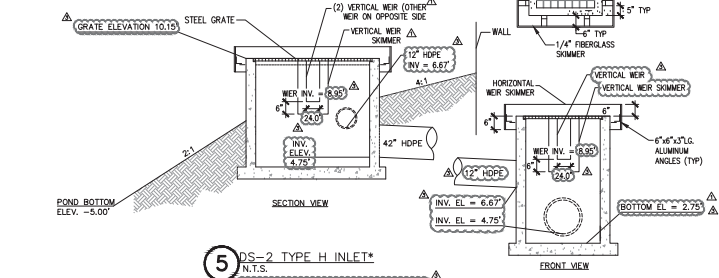

5 PS-2 TYPE H INLET*
PLEASE REFER TO DETAIL 15 ON SHEET C9.2 FOR NUTRIENT FILTRATION SYSTEM

6 NOT USED

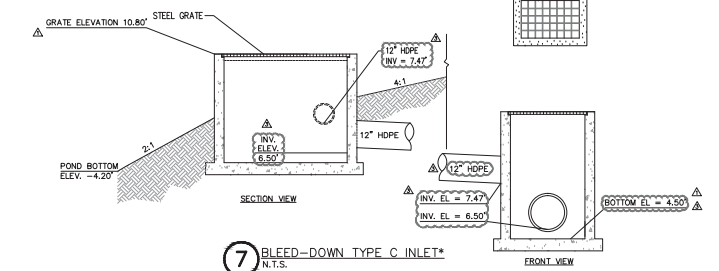

7 BLEED-DOWN TYPE C INLET*
PLEASE REFER TO DETAIL 16 ON SHEET C9.3 FOR NUTRIENT FILTRATION SYSTEM

DIMENSIONS AND QUANTITIES										
D	A	B	C	E	F	G	SINGLE PIPE	DOUBLE PIPE	TRIPLE PIPE	LOAD
15	1.92	2.18	4.10	2.06	5	1.22	4.63	7.21	9.79	134.97
18	1.97	2.74	4.71	2.56	6	1.41	4.92	7.70	10.58	134.49
24	2.04	3.61	5.91	3.56	7	1.73	5.20	8.92	12.51	145.75
30	2.15	4.50	7.10	4.58	8	2.00	6.08	10.33	14.58	188.63
36	2.28	5.38	8.33	5.56	9	2.24	6.87	11.78	16.88	215.99
42	2.34	7.20	9.50	6.50	10	2.45	7.25	13.20	19.20	252.25
48	2.43	8.33	10.76	7.50	11	2.65	7.83	14.58	21.30	280.09
54	2.52	9.44	11.96	8.50	12	2.85	8.42	16.00	23.70	314.42
60	2.62	10.58	13.18	9.58	14	3.00	9.00	17.50	26.00	342.00
66	2.71	11.68	14.38	10.58	15	3.18	9.58	18.25	27.25	372.00
72	2.80	12.80	15.60	11.58	16	3.30	10.18	20.10	30.18	405.18
78	2.87	13.92	16.80	12.58	17	3.45	10.75	21.75	32.75	441.75
84	2.94	15.00	18.00	13.58	18	3.60	11.30	23.40	35.40	480.40
90	3.00	16.10	19.20	14.58	19	3.75	11.85	25.10	38.10	521.10
96	3.06	17.20	20.40	15.58	20	3.90	12.40	26.80	40.80	563.80
102	3.12	18.30	21.60	16.58	21	4.05	12.95	28.50	43.50	608.50
108	3.18	19.40	22.80	17.58	22	4.20	13.50	30.20	46.20	655.20
114	3.24	20.50	24.00	18.58	23	4.35	14.05	31.90	48.90	703.90
120	3.30	21.60	25.20	19.58	24	4.50	14.60	33.60	51.60	753.60
126	3.36	22.70	26.40	20.58	25	4.65	15.15	35.30	54.30	804.30
132	3.42	23.80	27.60	21.58	26	4.80	15.70	37.00	57.00	856.00
138	3.48	24.90	28.80	22.58	27	4.95	16.25	38.70	59.70	909.00
144	3.54	26.00	30.00	23.58	28	5.10	16.80	40.40	62.40	963.00
150	3.60	27.10	31.20	24.58	29	5.25	17.35	42.10	65.10	1018.00
156	3.66	28.20	32.40	25.58	30	5.40	17.90	43.80	67.80	1074.00
162	3.72	29.30	33.60	26.58	31	5.55	18.45	45.50	70.50	1131.00
168	3.78	30.40	34.80	27.58	32	5.70	19.00	47.20	73.20	1189.00
174	3.84	31.50	36.00	28.58	33	5.85	19.55	48.90	75.90	1248.00
180	3.90	32.60	37.20	29.58	34	6.00	20.10	50.60	78.60	1308.00
186	3.96	33.70	38.40	30.58	35	6.15	20.65	52.30	81.30	1369.00
192	4.02	34.80	39.60	31.58	36	6.30	21.20	54.00	84.00	1431.00
198	4.08	35.90	40.80	32.58	37	6.45	21.75	55.70	86.70	1494.00
204	4.14	37.00	42.00	33.58	38	6.60	22.30	57.40	89.40	1558.00
210	4.20	38.10	43.20	34.58	39	6.75	22.85	59.10	92.10	1623.00
216	4.26	39.20	44.40	35.58	40	6.90	23.40	60.80	94.80	1689.00
222	4.32	40.30	45.60	36.58	41	7.05	23.95	62.50	97.50	1756.00
228	4.38	41.40	46.80	37.58	42	7.20	24.50	64.20	100.20	1824.00
234	4.44	42.50	48.00	38.58	43	7.35	25.05	65.90	102.90	1893.00
240	4.50	43.60	49.20	39.58	44	7.50	25.60	67.60	105.60	1963.00
246	4.56	44.70	50.40	40.58	45	7.65	26.15	69.30	108.30	2034.00
252	4.62	45.80	51.60	41.58	46	7.80	26.70	71.00	111.00	2106.00
258	4.68	46.90	52.80	42.58	47	7.95	27.25	72.70	113.70	2179.00
264	4.74	48.00	54.00	43.58	48	8.10	27.80	74.40	116.40	2253.00
270	4.80	49.10	55.20	44.58	49	8.25	28.35	76.10	119.10	2328.00
276	4.86	50.20	56.40	45.58	50	8.40	28.90	77.80	121.80	2403.00
282	4.92	51.30	57.60	46.58	51	8.55	29.45	79.50	124.50	2479.00
288	4.98	52.40	58.80	47.58	52	8.70	30.00	81.20	127.20	2556.00
294	5.04	53.50	60.00	48.58	53	8.85	30.55	82.90	130.00	2634.00
300	5.10	54.60	61.20	49.58	54	9.00	31.10	84.60	132.70	2712.00
306	5.16	55.70	62.40	50.58	55	9.15	31.65	86.30	135.40	2791.00
312	5.22	56.80	63.60	51.58	56	9.30	32.20	88.00	138.10	2871.00
318	5.28	57.90	64.80	52.58	57	9.45	32.75	89.70	140.80	2952.00
324	5.34	59.00	66.00	53.58	58	9.60	33.30	91.40	143.50	3033.00
330	5.40	60.10	67.20	54.58	59	9.75	33.85	93.10	146.20	3115.00
336	5.46	61.20	68.40	55.58	60	9.90	34.40	94.80	148.90	3198.00
342	5.52	62.30	69.60	56.58	61	10.05	34.95	96.50	151.60	3282.00
348	5.58	63.40	70.80	57.58	62	10.20	35.50	98.20	154.30	3367.00
354	5.64	64.50	72.00	58.58	63	10.35	36.05	100.00	157.00	3453.00
360	5.70	65.60	73.20	59.58	64	10.50	36.60	101.70	159.70	3540.00
366	5.76	66.70	74.40	60.58	65	10.65	37.15	103.40	162.40	3628.00
372	5.82	67.80	75.60	61.58	66	10.80	37.70	105.10	165.10	3717.00
378	5.88	68.90	76.80	62.58	67	10.95	38.25	106.80	167.80	3807.00
384	5.94	70.00	78.00	63.58	68	11.10	38.80	108.50	170.50	3898.00
390	6.00	71.10	79.20	64.58	69	11.25	39.35	110.20	173.20	3990.00
396	6.06	72.20	80.40	65.58	70	11.40	39.90	111.90	175.90	4083.00
402	6.12	73.30	81.60	66.58	71	11.55	40.45	113.60	178.60	4177.00
408	6.18	74.40	82.80	67.58	72	11.70	41.00	115.30	181.30	4272.00
414	6.24	75.50	84.00	68.58	73	11.85	41.55	117.00	184.00	4368.00
420	6.30	76.60	85.20	69.58	74	12.00	42.10	118.70	186.70	4465.00
426	6.36	77.70	86.40	70.58	75	12.15	42.65	120.40	189.40	4563.00
432	6.42	78.80	87.60	71.58	76	12.30	43.20	122.10	192.10	4662.00
438	6.48	79.90	88.80	72.58	77	12.45	43.75	123.80	194.80	4762.00
444	6.54	81.00	90.00	73.58	78	12.60	44.30	125.50	197.50	4863.00
450	6.60	82.10	91.20	74.58	79	12.75	44.85	127.20	200.20	4965.00
456	6.66	83.20	92.40	75.58	80	12.90	45.40	128.90	202.90	5068.00
462	6.72	84.30	93.60	76.58	81	13.05	45.95	130.60	205.60	5172.00
468	6.78	85.40	94.80	77.58	82	13.20	46.50	132.30	208.30	5277.00
474	6.84	86.50	96.00	78.58	83	13.35	47.05	134.00	211.00	5383.00
480	6.90	87.60	97.20	79.58	84	13.50	47.60	135.70	213.70	5490.00
486	6.96	88.70	98.40	80.58	85	13.65	48.15	137.40	216.40	5598.00
492	7.02	89.80	99.60	81.58	86	13.80	48.70	139.10	219.10	5707.00
498	7.08	90.90	100.80	82.58	87	13.95	49.25	140.80	221.80	5817.00
504	7.14	92.00	102.00	83.58	88	14.10	49.80	142.50	224.50	5928.00
510	7.20	93.10	103.20	84.58	89	14.25	50.35	144.20	227.20	6040.00
516	7.26	94.20	104.40	85.58	90	14.40	50.90	145.90	230.00	6153.00
522	7.32	95.30	105.60	86.58	91	14.55	51.45	147.60	232.70	6267.00
528	7.38	96.40	106.80	87.58	92	14.70	52.00	149.30	235.40	6382.00
534	7.44	97.50	108.00	88.58	93	14.85	52.55	151.00	238.10	6498.00
540										

SUNTREE TECHNOLOGIES INC.™ NUTRIENT REMOVING FILTRATION SYSTEM™ MODEL NO: NRFS-4-4-TBD

GENERAL NOTES:

1. Pipe inflow area = TBD ft²
2. Cubic feet of Media = 27.00 ft³
3. FLOOR OF VAULT TO HAVE HYDRO-SLIDE SYSTEM.
4. CONCRETE 28 DAY COMPRESSIVE STRENGTH FC=5000 PSI
5. REINFORCING: ASTM A-615 GRADE 60
6. SUPPORTS AN H2O LOADING AS INDICATED BY AASHTO.
7. JOINT SEALANT: BUTYL RUBBER SS-S-00210
8. ALL WALLS 6", BOTTOM 6", & TOP TO BE 6"
9. INFLOW AND OUTFLOW PIPES ARE TO BE FLUSH WITH THE INSIDE SURFACE OF THE CONCRETE STRUCTURE. (CAN NOT INTRUDE BEYOND FLUSH)
10. MANUFACTURER TO SUPPLY ALL MATERIALS UNLESS OTHERWISE NOTED
11. MINIMUM CRITICAL DIMENSIONS ARE SHOWN IN A PENTAGON BLOCK

INSTALLATION NOTES:

1. CONTRACTOR TO PROVIDE ALL LABOR, EQUIPMENT, MATERIALS AND INCIDENTALS REQUIRED TO OFFLOAD AND INSTALL THE SYSTEM AND APPURTENANCES IN ACCORDANCE WITH THIS DRAWING AND THE MANUFACTURERS SPECIFICATIONS, UNLESS OTHERWISE STATED IN MANUFACTURERS CONTRACT.
2. UNIT MUST BE INSTALLED ON LEVEL BASE. MANUFACTURER RECOMMENDS A MINIMUM OF 6" LEVEL ROCK BASE UNLESS SPECIFIED BY THE PROJECT ENGINEER. CONTRACTOR IS RESPONSIBLE TO VERIFY PROJECT ENGINEERS RECOMMENDED BASE SPECIFICATIONS.
3. ALL PIPES MUST BE FLUSH WITH INSIDE SURFACE OF CONCRETE. (PIPES CANNOT INTRUDE BEYOND FLUSH). ALL PIPES SHALL BE SEALED WATER TIGHT WITH A NON-SHRINK GROUT PER MANUFACTURERS STANDARD CONNECTION DETAIL AND SHALL MEET OR EXCEED REGIONAL PIPE CONNECTION STANDARDS.
4. CONTRACTOR TO SUPPLY AND INSTALL ALL EXTERNAL CONNECTING PIPES.
5. CONTRACTOR RESPONSIBLE FOR INSTALLATION OF ALL RISERS, MANHOLES, AND HATCHES (UNLESS CAST INTO THE TOP). CONTRACTOR TO GROUT ALL MANHOLES AND HATCHES TO MATCH FINISH SURFACE UNLESS SPECIFIED OTHERWISE.

1. The BAM media shall be primarily of a mineral content. No more than 5% of the media passing the 200 sieve is allowed. The mix is composed of tire chips, with no metals, and a 3/8" blend of expanded clay. The mix has an average dry weight of less than sixty (60) pounds per cubic foot, non-flammable up to 482 degrees Fahrenheit (250 degrees Celsius, and a moisture holding capacity of a least 20%. The filtered water has no change in pH and water from the media must have no acute or chronic toxicity. Water holding capacity must be at least 30% as measured by fillable porosity. The permeability is less than two (2) gallons per minute per square foot of new clean filter media as measured at static head of six (6) inches. The removable capacity must exceed 0.2mg OP/gram of media during normal operating conditions. An example of the blend to meet these specifications is known as "Bold & Gold".

2. The Bold and Gold (BAM) will be qualified by the receipt of a letter of authenticity from the supplier of said media. On said letter of authenticity, there will be a specific identification number for the qualifying blend of media, verifying the media meets the patented formulations set forth by the University of Central Florida (UCF), as well as identifying the specific project where it will be utilized.

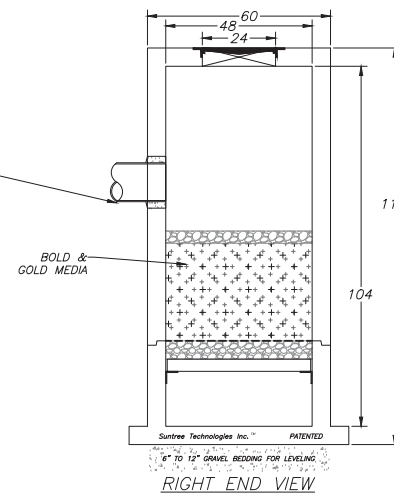
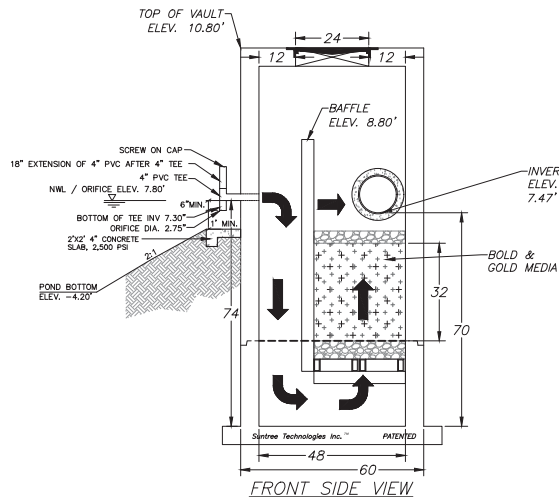
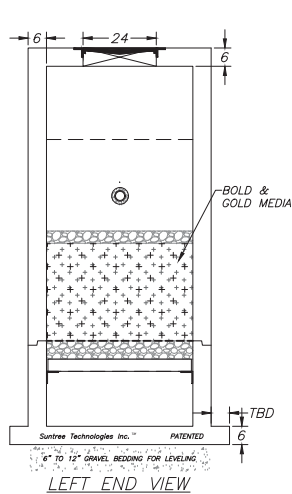
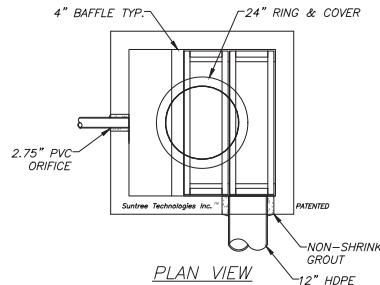

PATENTED
AND PATENTS PEND.

Suntree Technologies Inc.
798 Clearlake Road, Cocoa, Florida 32922
PH: 321-637-7552 Fax: 321-637-7554

Suntree Technologies Inc. owns the copyright to and to this drawing. This drawing contains Suntree's proprietary, confidential, and privileged information. Any unauthorized review, use, disclosure, or distribution is prohibited.

16 NUTRIENT REMOVING FILTRATION SYSTEM MEDIA FILTER
(B&G FCT) WITH BOLD & GOLD (BAM) FOR EAST WET POND
N.T.S.

SUNTREE TECHNOLOGIES INC.™ 798 CLEARLAKE RD, SUITE #2 COCOA, FL 32922		PROJECT LOG:	CAD	REVISIONS	DATE
NUTRIENT REMOVING FILTRATION SYSTEM MODEL NO: NRFS-4-4-TBD		-----	A.B.1	-----	00/00/00
START DATE: 00/00/00	SCALE: N/A	PROJECT NAME:			
DRAFTER: A.B.1.	UNITS: INCHES	-----			
CHECKED BY: A.B.1.	PO #: 00000	00-00-00-00-00			

CONTRACTOR TO COORDINATE FILTRATION SYSTEM SIZING & SPECIFS WITH:
SUNTREE TECHNOLOGIES, INC C/O
EVAN SELBINGER
PHONE: (321) 637-7522
EMAIL: EVANS@SUNTREETECH.COM

SCALE	N.T.S.	DRAWN	G. SANDHEZ	DESIGNED	L. GLASSON	CHECKED	L. GLASSON	DATE	1/24/2017
PROJECT	CE0-003	NORTHERN OAKS SUBDIVISION CITY OF WINTER SPRINGS, FLORIDA							
SHEET	C9.3	DRAINAGE DETAILS							
BOARD OF PROFESSIONAL ENGINEERING CERTIFICATE NO. 28973		BAS ENGINEERING CONSULTANTS, LLC DBA APPIAN ENGINEERING, LLC		2221 LEE ROAD, SUITE 17 WINTER PARK, FLORIDA 32789		(407) 960-5868		DATE	REV



Landscape Designs, LLC

Landscape Architecture & Site Planning

4400 Collier Drive
Winter Park, FL 32789
321-407-4434
Fax: 407-971-3894

PROJECT AND OWNER
NORTHERN OAKS SUBDIVISION
Winter Springs Florida

IBI Group Inc.
2800 Mulholland Center Parkway
Suite 101
Melbourne, FL 32935
(407) 880-2180

CONSULTANTS

LANDSCAPE ARCHITECT
CARL J. KELLY JR., RLA

REC.#: 0001764

PROJECT NO. IBI07.01
DESIGNED BY CJK
DRAWN BY CJK
CHECKED BY CJK
DATE 10/24/16

ISSUED FOR:
11/22/16 City Comments
01/05/17 City Comments
02/02/17 Sight Lines
02/15/17 Site Changes
02/24/17 Site Changes

DRAWING SCALE



DRAWING TITLE
LANDSCAPE SITE PLAN & PLANTING DETAILS

DRAWING NUMBER

LS-04

SHEET 04 OF 04

PLANT SCHEDULE

Table with columns: DECIDUOUS TREES, EVERGREEN TREES, FLOWERING TREES, PALM TREES, SHRUBS, GRASSES, GROUND COVERS, DE VEG, and MISCELLANEOUS ITEMS. Each row lists botanical and common names, quantities, and sizes.

LANDSCAPE REQUIREMENTS
REQUIRED TREES: 3 TREES PER LOT (105 TREES)
Residential lot trees shall be installed following the development of each lot.

Table titled 'Residential Lot Trees (3 Trees Max - 35 Lots)' with columns: Species, Size, Quantity, and Cost Value.

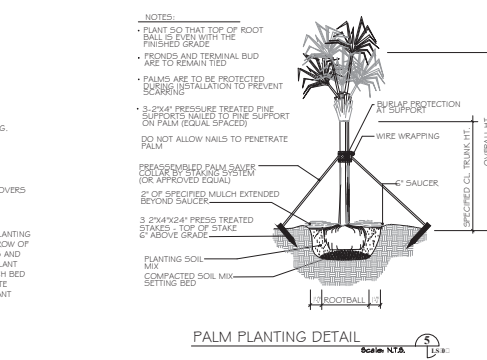
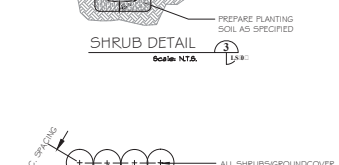
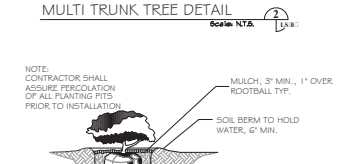
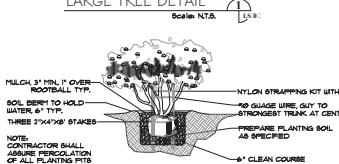
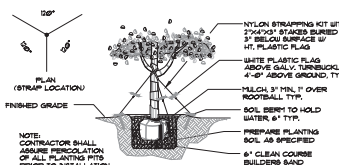
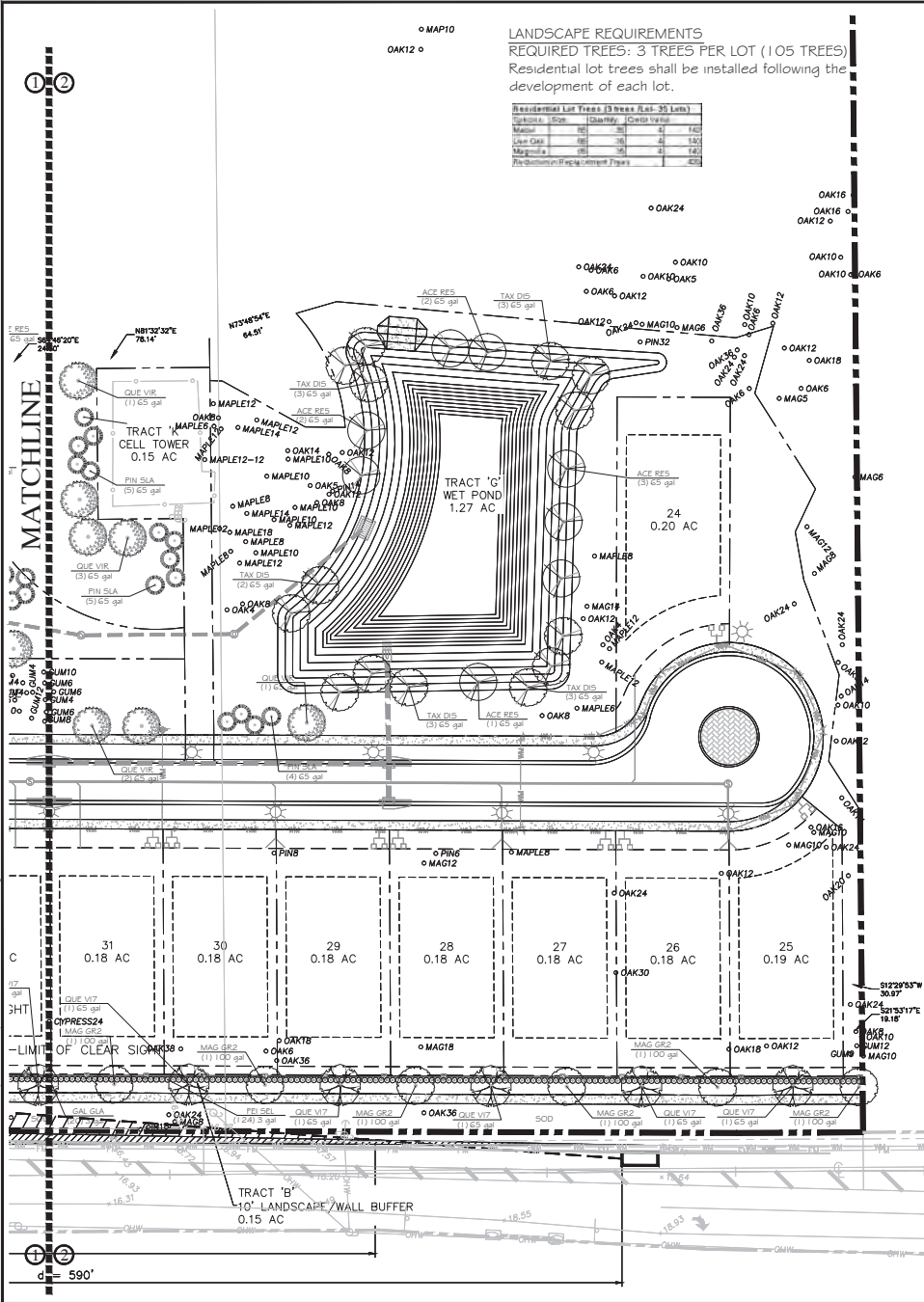

C:\Users\IBI07.01\NorthernOaks\landscapes\landscapes\Code\Plan\NOC-LS-LND.dwg



Landscape Designs, LLC

Landscape Architecture
Site Planning

4465 Collette Lane
Winter Park, FL 32789
P: (407) 494-3434
F: (407) 471-3884

PROJECT AND OWNER

NORTHERN OAKS SUBDIVISION
Winter Springs Florida

IBI Group Inc.
2800 Mulholland Parkway
Suite 101
Melbourne, FL 32931
(407) 888-2100

CONSULTANTS

LANDSCAPE ARCHITECT

CARL J. KELLY JR., RLA

REG.#: 0001764

PROJECT NO. IB107.01

DESIGNED BY CJK

DRAWN BY CJK

CHECKED BY CJK

DATE 10/24/16

ISSUED FOR:

01/05/17 City Comments

02/15/17 Site Changes

02/24/17 Site Changes

DRAWING SCALE



DRAWING TITLE

HARDSCAPE SITE PLAN & DETAILS

DRAWING NUMBER

HS-01

SHEET 01 OF 02

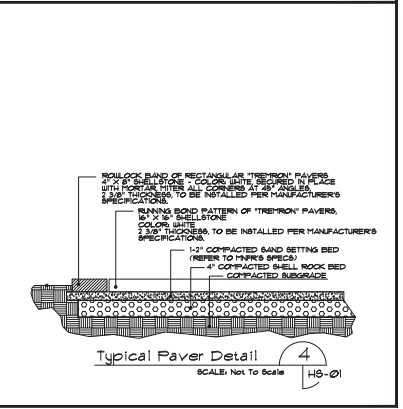
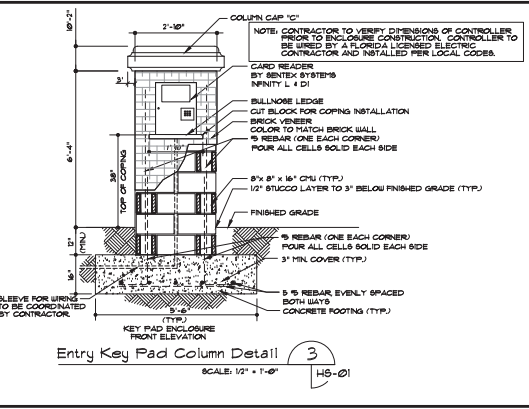
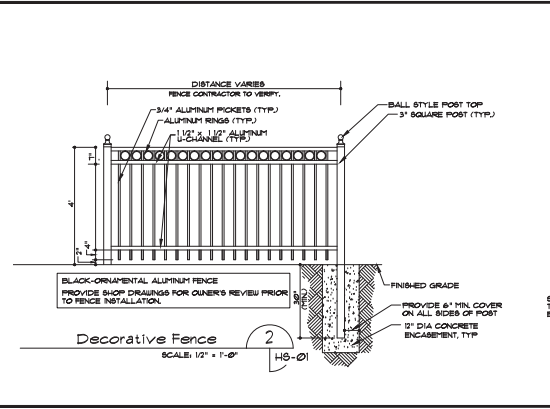
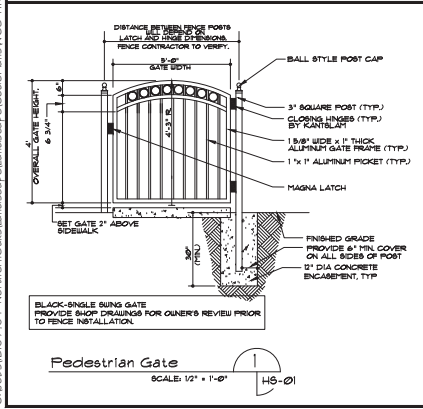
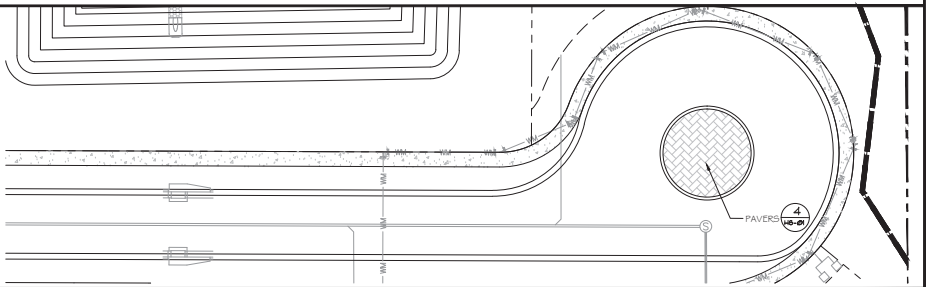
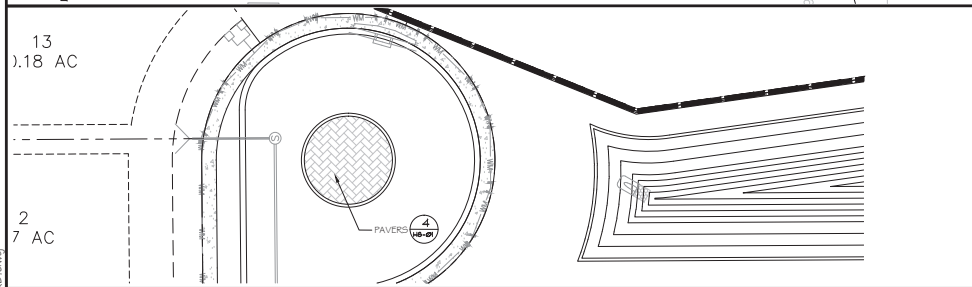
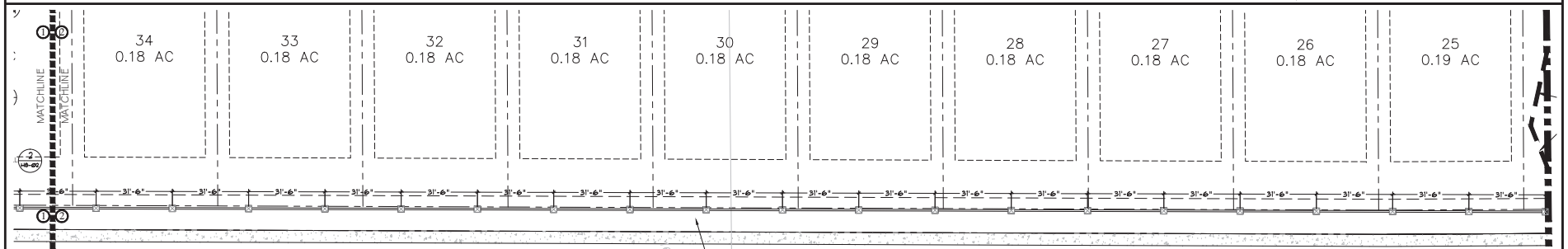
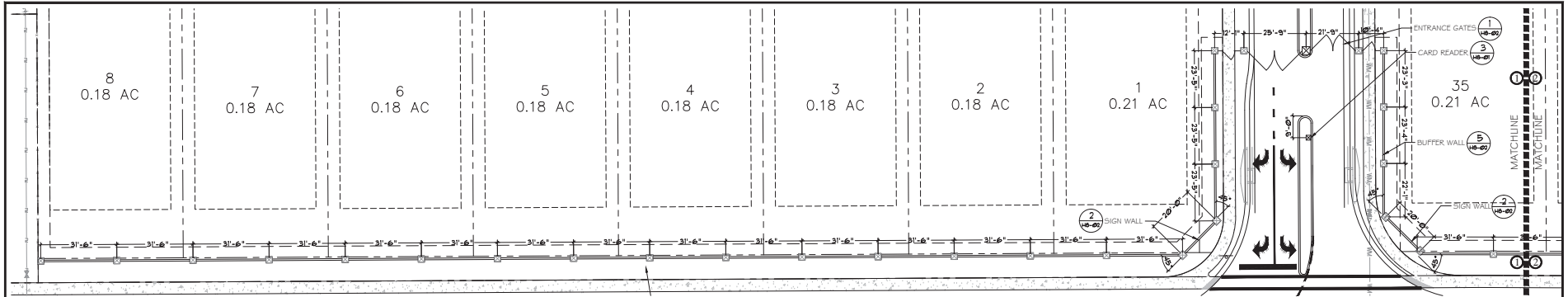

C:\Users\BIC7.01\Documents\Landscapes\Code\Plans\NOC-HRD.dwg



Landscapes Architecture & Site Planning

4405 California Lane
Winter Park, FL 32789
352-407-4614
Fax: (352) 471-3804

PROJECT AND OWNER

NORTHERN OAKS SUBDIVISION
Winter Springs Florida

IBI Group Inc.
2600 Mountain Center Parkway
Suite 101
Maitland, FL 32751
(407) 888-8200

CONSULTANTS

LANDSCAPE ARCHITECT

CARL J. KELLY JR., RLA

REG.# 0001764

PROJECT NO. 18107.01

DESIGNED BY CJK

DRAWN BY CJK

CHECKED BY CJK

DATE 10/24/16

ISSUED FOR:

01/05/17 City Comments

02/15/17 Site Changes

02/24/17 Site Changes

DRAWING SCALE

SCALE AS SHOWN

DRAWING TITLE

HARDSCAPE DETAILS

DRAWING NUMBER

HS-02

SHEET 02 OF 02

STRUCTURAL DESIGN CRITERIA:

- A. STRUCTURAL DESIGN IS IN ACCORDANCE WITH THE GOVERNING PROVISIONS OF THE FOLLOWING CODES, STANDARDS AND SPECIFICATIONS.
 1. FLORIDA BUILDING CODE - 2014 EDITION
 2. ACCE 1-02 MIN. DESIGN LOADS FOR BUILDINGS AND OTHER STRUCTURES.
 3. ACI 318-02, BUILDING CODE REQUIREMENTS FOR REINFORCED CONCRETE.
 4. ACI 308-99, BUILDING CODE REQUIREMENTS FOR MASONRY STRUCTURES.
 5. AISC SPECIFICATION FOR STRUCTURAL STEEL, BUILDING, ALSO, NINTH EDITION.
 6. AISI D12 STRUCTURAL WELDING CODE - STEEL.
 7. ALUMINUM DESIGN MANUAL, FOURTH EDITION.
 8. AISI D12 STRUCTURAL WELDING CODE - ALUMINUM.
- B. SUPERIMPOSED DESIGN LOADS:
 - LIVE LOADS (MIN) DEAD LOADS:
 - GENERAL: 20 PSF
 - WIND LOADS: DESIGN WIND SPEED: 140 MPH
 - MEAN ROOF HEIGHT: 15 FEET
 - EXPOSURE: B
 - STRUCTURE: SIGA, CP-12, G+SS
 - DESIGN WIND PRESSURE: 22 PSF
- C. FOUNDATIONS:
 1. ASSUMED SAFE BEARING PRESSURE = 2,000 PSF.
 2. ALL UNSUITABLE SOIL SHALL BE REMOVED AND REPLACED WITH CLEAN STRUCTURAL FILL PLACED IN LOOSE LAYERS NOT EXCEEDING EIGHT (8") INCHES AND COMPACTED TO 98% (ASTM D1558) STANDARD PROCTOR OF MAX DRY DENSITY.
 3. CONTRACTOR SHALL PREPARE THE SUBSURFACE SOILS PER THE GEOTECHNICAL REQUIREMENTS STIPULATED IN GEOTECHNICAL REPORT.

- GENERAL:
- A. ALL DIMENSIONS AND PLACEMENTS SPECIFIED WITHIN THIS DRAWING ARE TO BE VERIFIED BY OWNER PRIOR TO INSTALLATION.
 - B. ALL ELEVATIONS ARE REFERENCED TO FINISHED GRADE. EL. 100.000' ± @ 0'-0". ALL ELEVATIONS SHOWN ON PLANS ARE REFERENCED TO THIS DATUM UNLESS NOTED.
 - C. THE GENERAL CONTRACTOR SHALL BE RESPONSIBLE FOR ALL DIMENSIONS MARKED (V/U) PRIOR TO INDICATION OF CONTRACT NO.
 - D. NO STRUCTURAL MEMBER SHALL BE CUT, NOTCHED OR OTHERWISE REDUCED IN STRENGTH WITHOUT THE PRIOR NOTIFICATION OF THE STRUCTURAL ENGINEER.
 - E. THE GENERAL CONTRACTOR SHALL COORDINATE ALL OTHER DISCIPLINES FOR ANY ITEMS WHICH EFFECT THE STRUCTURAL DRAWINGS.
 - F. TEMPORARY BRACINGS, GUY WIRES, ETC. SHALL BE USED WHERE NECESSARY TO ADEQUATELY RESIST ALL CONSTRUCTION LOADS.
 - G. INSURE POSITIVE DRAINAGE IN ALL AREAS.
 - H. CONTRACTOR TO VERIFY ALL UTILITIES PRIOR TO CONSTRUCTION NOTIFY LANDSCAPE ARCHITECT OF ANY CONFLICTS BETWEEN PROPOSED WALLS/COLUMNS AND EXISTING UTILITIES.

CAST-IN-PLACE REINFORCED CONCRETE:

- A. ALL CONCRETE WORK SHALL CONFORM TO ACI STANDARD BUILDING CODE REQUIREMENTS FOR REINFORCED CONCRETE (ACI 318-02/08/11).
- B. ALL CONCRETE WORK SHALL ALSO CONFORM TO ALL APPLICABLE SECTIONS OF THE F.D.O.T. STANDARD SPECIFICATIONS FOR ROAD AND BRIDGE CONSTRUCTION.
- C. MINIMUM 28 DAY COMPRESSIVE STRENGTH:
 - CONCRETE WALKS, SIDEWALK BANDINGS, BENCH FOUNDATIONS AND HANDICAP RAMPS: CLASS 1
 - CONCRETE MOBILIAR BARRIERS AND INTERNAL BANDINGS: CLASS 1
 - CONCRETE CURBS, CURBS AND GUTTER, 6" DRIVEWAY BANDINGS, HEADER CURBS
 - CONCRETE STREET LIGHT POLE BASES AND TRAFFIC POLE BASES, AND TREE GRATE COULDS: CLASS II
- D. REINFORCING STEEL SHALL CONFORM TO ASTM A-615 GRADE 60. WELDED WIRE FABRIC SHALL CONFORM TO ASTM A-185 16"x6", 21 GAUF.
- E. TERMINATE AND DISCONTINUE TOP BARS WITH 180 DEGREE STANDARD HOOK UNLESS OTHERWISE NOTED.
- F. AT CHANGES IN DIRECTION OF CONCRETE WALLS, STEEP ROOFINGS AND BOND BEARS, PROVIDE CORNER BARS AT SAFE SIZE AND SPACING AS HORIZONTAL STEEL.
- G. METAL EXPANSION CAPS, TO BE FURNISHED WITH ONE END OF EACH COIL BAR IN EXPANSION JOINTS. CAPS TO BE A MINIMUM OF 3" IN LENGTH WITH ONE END CLOSED TO ALLOW BAR MOVEMENT OF NOT LESS THAN 1/8" UNLESS OTHERWISE INDICATED. PLASTIC COATED COIL BARS MAY BE USED IF APPROVED BY ENGINEER.
- H. JOINT MATERIALS: JOINT SEALERS IS TO BE GRAY SOLIDARITIC SMI MANUFACTURED BY REINFORCED CONCRETE PRODUCTS, INC. UNLESS OTHERWISE INDICATED.
- I. CONTRACTION JOINTS: TO BE PROVIDED TO A DEPTH 1/4 OF CONCRETE THICKNESS, AS FOLLOWS:
 1. TIED JOINTS:
 2. SAVED JOINTS IF REQUIRED, TO BE CUT INTO HARDENED CONCRETE AS SOON AS SURFACE WILL ALLOW.
 3. CONTRACTION JOINTS ARE TO BE PLACED AT INTERVALS EQUAL TO THE WIDTH OF THE CONSTRUCTION JOINTS FOR CONCRETE BANDING IN THE STREET AND SIDEWALK SHALL BE AT 10 FOOT INTERVALS (MAX).
- K. CONSTRUCTION JOINTS: PLACE CONSTRUCTION JOINTS AT THE END OF ALL POURS AND AT LOCATIONS WHERE PLACEMENT OPERATIONS ARE STOPPED FOR A PERIOD OF MORE THAN 1/2 HOUR EXCEPT WHERE FOUR HOURS TERMINATE AT EXPANSION JOINTS.

L. EXPANSION JOINTS:

1. PROVIDE EXPANSION JOINTS BETWEEN ADJUTING CONCRETE CURBS, WALKS, WALLS & COLUMNS AND OTHER NON-YIELDING MATERIALS, UNLESS OTHERWISE INDICATED ON HARDSCAPE DETAILS.
2. FOR CURBS AND GUTTER WORK EXPANSION JOINTS SHALL BE PLACED AT EVERY ONE HUNDRED LINEAR FEET.
3. ALL EXPOSED EXPANSION JOINT MATERIALS SHALL BE RECESSED 1/4 INCH AND SEALED WITH THE JOINT SEALER AS SPECIFIED.

M. CONCRETE FINISHES:

1. AFTER STRIKING OFF AND CONSOLIDATING CONCRETE, SMOOTH THE SURFACE BY SCREEDING AND FLOATING. USE HAND METHODS ONLY WHERE MECHANICAL FLOATING IS NOT POSSIBLE. ADJUST THE FLOATING TO COMPACT THE SURFACE AND PRODUCE A UNIFORM TEXTURE. THE USE OF ADDITIONAL WATER WILL BE PROHIBITED IN ALL PHASES OF THE FINISHING.
2. AFTER FLOATING, TEST SURFACE FOR TRENDS WITH A 10 FOOT STRAIGHTEDGE. DISTRIBUTE CONCRETE AS REQUIRED TO REMOVE SURFACE IRREGULARITIES, AND REPEAT REPAIRED AREAS TO PROVIDE A CONTINUOUS FINISH.
3. WORK EDGES OF GUTTERS, BACK TOP EDGE OF CURBS, SCORE LINE AND FORMED JOINTS WITH AN EDGERS TOOL AND ROUND TO 1/2" RADIUS UNLESS OTHERWISE INDICATED ON HARDSCAPE DETAILING. ELIMINATE ANY TOOL MARKS ON CONCRETE SURFACE.
4. AFTER COMPLETION OF FLOATING, AND WHEN EXCESS MOISTURE OR SURFACE SHEEN HAS DISAPPEARED, COMPLETE SURFACE FINISHING AS SPECIFIED ON DETAILS.
5. DO NOT REMOVE FORMS FOR 24 HOURS AFTER CONCRETE HAS BEEN PLACED. AFTER FORM REMOVAL, CLEAN EDGES AND POINT-UP ANY MINOR MONEY-CORDED AREAS. REMOVE AND REPLACE AREAS OR SECTIONS WITH MAJOR DEFECTS.

N. GENERAL:

- CONTRACTOR SHALL PLACE CONSTRUCTION JOINTS AT THE END OF ALL POURS AND AT LOCATIONS WHERE PLACEMENT OPERATIONS ARE STOPPED FOR A PERIOD OF MORE THAN 1/2 HOUR EXCEPT WHERE FOUR HOURS TERMINATE AT EXPANSION JOINTS.
- CONTRACTOR SHALL PLACE CONSTRUCTION JOINTS AT THE END OF ALL POURS AND AT LOCATIONS WHERE PLACEMENT OPERATIONS ARE STOPPED FOR A PERIOD OF MORE THAN 1/2 HOUR EXCEPT WHERE FOUR HOURS TERMINATE AT EXPANSION JOINTS.
- CONTRACTOR SHALL PLACE CONSTRUCTION JOINTS AT THE END OF ALL POURS AND AT LOCATIONS WHERE PLACEMENT OPERATIONS ARE STOPPED FOR A PERIOD OF MORE THAN 1/2 HOUR EXCEPT WHERE FOUR HOURS TERMINATE AT EXPANSION JOINTS.
- CONTRACTOR SHALL PLACE CONSTRUCTION JOINTS AT THE END OF ALL POURS AND AT LOCATIONS WHERE PLACEMENT OPERATIONS ARE STOPPED FOR A PERIOD OF MORE THAN 1/2 HOUR EXCEPT WHERE FOUR HOURS TERMINATE AT EXPANSION JOINTS.

- CONCRETE MASONRY:
- A. DESIGN CRITERIA: ACI 530-08/ASCE 5-08, ACI 530-10/ASCE 5-09
 - B. HOLLOW UNITS: MIN. 4800 PSI @ 28 DAYS, MIN. 45% SOLID, ASTM C 90, GRADE N, HIGH STRENGTH BLOCK, NOMINAL WEIGHT, (F=2500 PSI).
 - C. MORTAR: ASTM C 270, TYPE S, MIN. 1800 PSI @ 28 DAYS, 3/8" FULL BEDDING, REMOVE MORTAR PROTRUDING INTO CELL CAVITIES TO BE REINFORCED.
 - D. GROUT: ASTM C 476, MIN. 2500 PSI @ 28 DAYS, 3/8" AGGREGATE MAX, 6"-10" SLUMP.
 - E. REINFORCEMENT:
 1. HORIZONTAL JOINTS: STD. CURB-O-WALL @ 16" O.C. USE PREFABRICATED CORNERS AND TEES @ WALL INTERSECTIONS OVER AND UNDER CONTINUED ENDS AND EXTEND INTO COLUMNS 12" MIN.
 2. VERTICAL AND HORIZONTAL REINFORCEMENT: ASTM A63, GRADE 60, TYP. @ WALL INTERSECTIONS, EACH SIDE OF OPENINGS, AND @ WALL ENDS. HOOK TOP OF ALL DISCONTINUED BARS, WALL CONT. REIN. @ BAR DIA. UNDO.
 3. USE BAR SPACERS IN EVERY 4TH COURSE WHERE CELLS ARE TO BE GROUDED.
 4. PROVIDE CLEAN OPENINGS FROM EACH GROUDED CELL. G-HIGH LIFT GROUDED SHALL BE USED WITH A MAXIMUM POUR OF 12"-0" IN 4" MAX. LIFTS WITH ONE HOUR BETWEEN LIFTS. VIBRATE EACH LIFT AND CONSOLIDATE PREVIOUS LIFT BEFORE PLACING NEXT LIFT. JOINTS TO BE FILLED WITH GROUT SHALL HAVE A MINIMUM CLEAR DIMENSION OF 3"x3". H. WHERE EXPANSION ANCHOR BOLTS ARE SET IN MASONRY WALLS, FULL BLOCK CELLS WITH GROUT FOR BOLTED COURSE AND TWO COURSES BELOW ANCHOR ELEVATION.

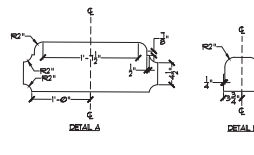
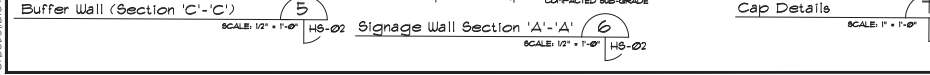
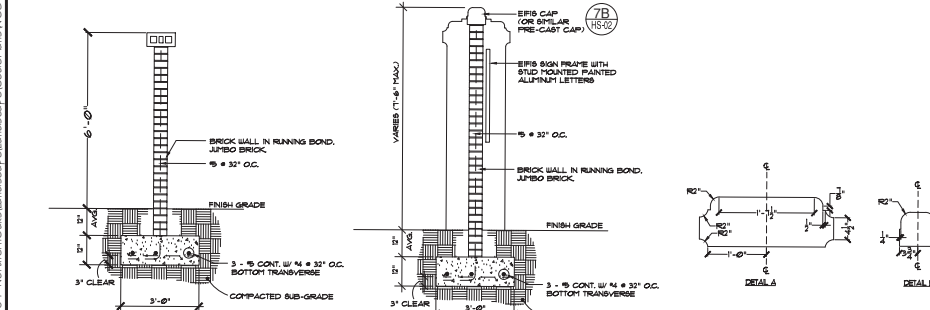
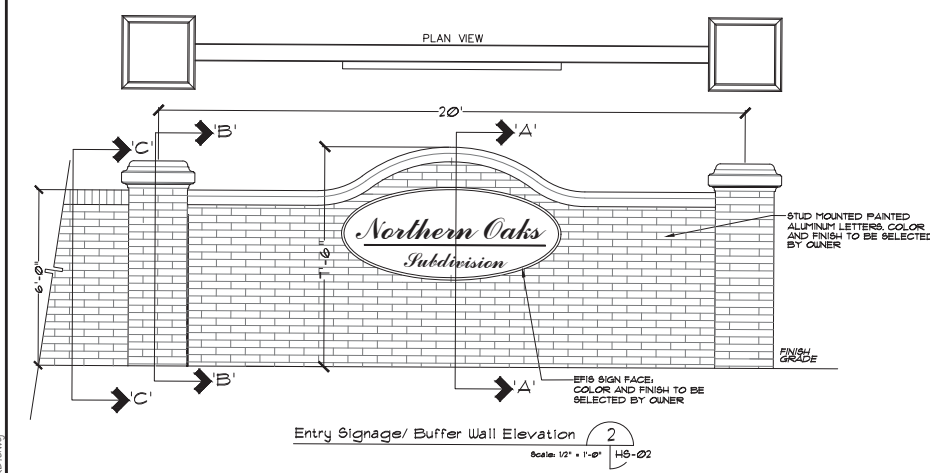
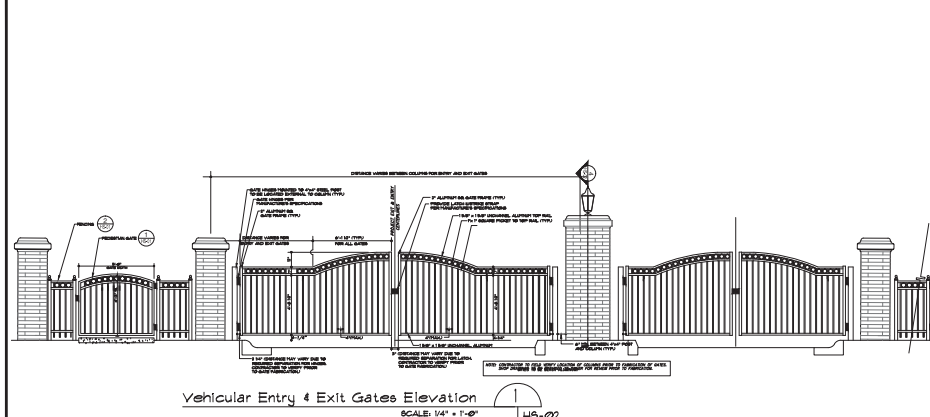
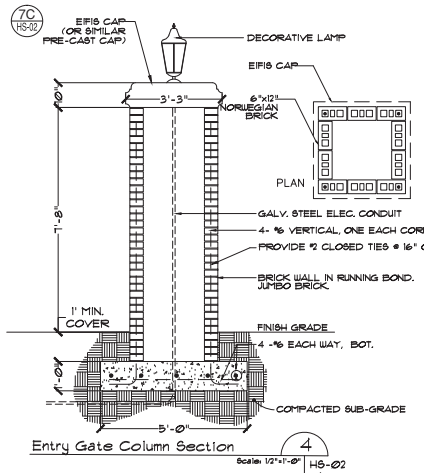
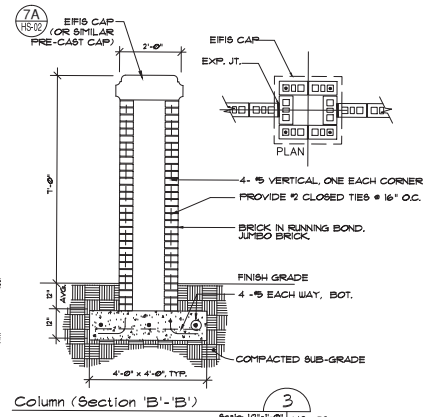

C:\Users\Bj07.01\OneDrive\landscapes\landscapes\Code\Plans\NCS-HRD.dwg



Landscape Designs, LLC
 ■ Landscape Architecture
 ■ Site Planning

4465 Collette Lane
 Winter Park, FL 32789
 (407) 494-0414
 Fax: (407) 471-3894

PROJECT AND OWNER

NORTHERN OAKS SUBDIVISION
 Winter Springs
 Florida

IBI Group Inc.
 3500 Midland Center Parkway
 Suite 101
 Maitland, FL 32751
 (407) 888-8180

CONSULTANTS

LANDSCAPE ARCHITECT
 CARL J. KELLY JR., RLA

REG.#: 0001764

PROJECT NO. IBI07.01
 DESIGNED BY CJK
 DRAWN BY CJK
 CHECKED BY CJK
 DATE 11/28/16

ISSUED FOR:
 01/05/17 City Comments
 02/14/17 Site Changes
 02/24/17 Site Changes

DRAWING SCALE



DRAWING TITLE

IRRIGATION SITE PLAN

DRAWING NUMBER

IR-01

SHEET 01 OF 02

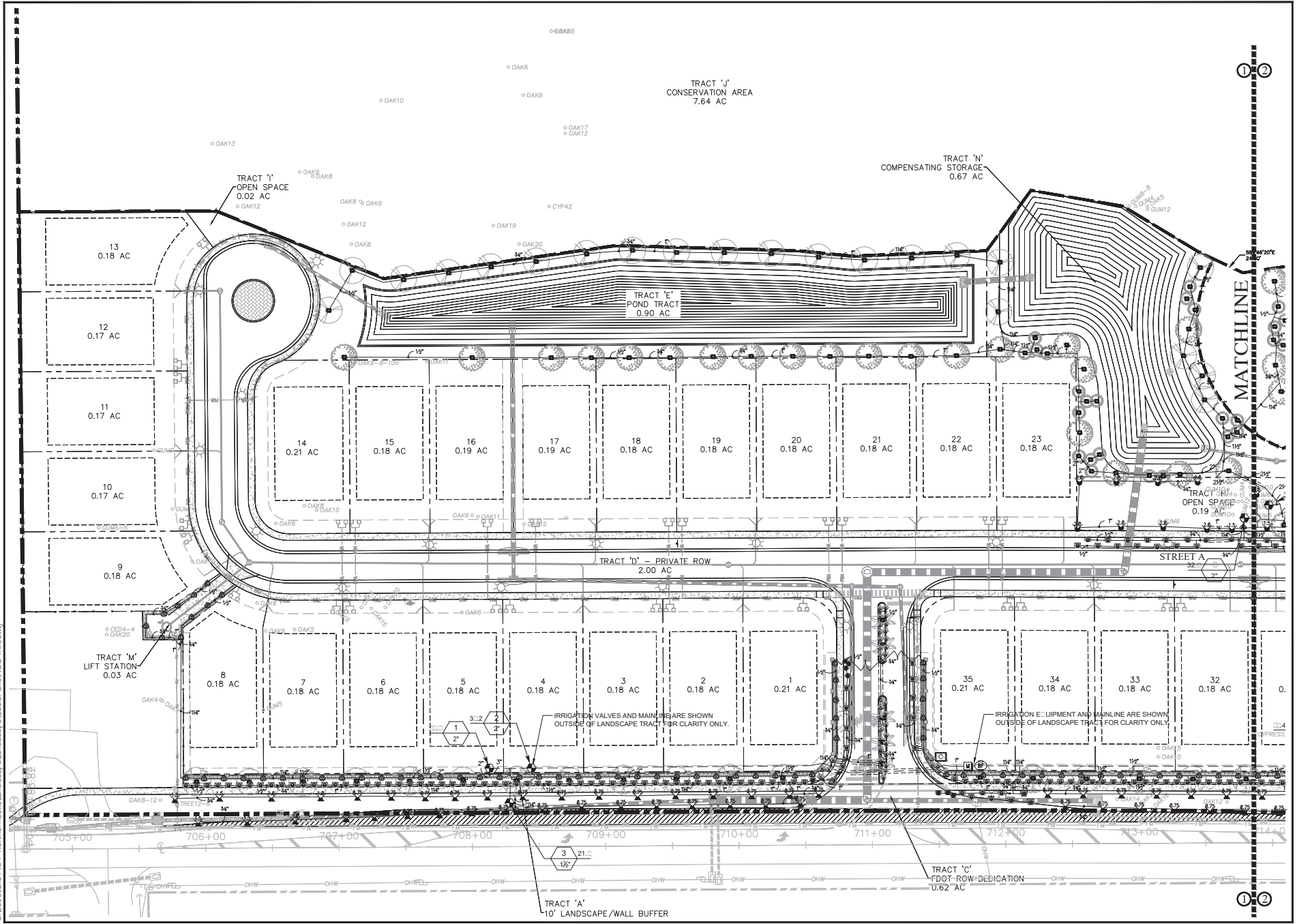

C:\Users\IBI07.01\Northern Oaks\Irrigation\Irrigation\Irrigation\Code\Plans\NDS-IRR.dwg

COMMISSION AGENDA

ITEM 401

Informational	
Consent	
Public Hearings	X
Regular	

March 13, 2017

KS

BF

Regular Meeting

City Manager

Department

REQUEST:

The Community Development Department requests the City Commission hold a public hearing for the approval of 1) Final Engineering Plans; and 2) Waiver Request for Northern Oaks, a proposed 35-lot single-family residential subdivision located just east of the intersection of State Road 434 and State Road 417.

SYNOPSIS:

Northern Oaks is a proposed 35-lot single-family residential subdivision on 20.48 acres located east of the intersection of State Road 434 and State Road 417. The applicant, Madichristo Land Holdings, LLC, is requesting approval of the Final Engineering Plans and a waiver request for the side and rear setbacks.

CONSIDERATIONS:

APPLICANT AND PROPERTY INFORMATION:

- Applicant/Owner name and address and authorized representative: Madichristo Land Holdings, LLC, 1520 Whitstable Court, Lake Mary, FL 32746
- Property addresses: 908 West SR 434
- Current FLUM Designations: City of Winter Springs Low Density Residential
- Current Zoning Designations: City of Winter Springs R-1 (one-family dwelling district)

Lot #	Parcel ID	Street #	Street Name
1	04-21-31-511-0000-0010	957	TALON PLACE
2	04-21-31-511-0000-0020	961	TALON PLACE
3	04-21-31-511-0000-0030	965	TALON PLACE
4	04-21-31-511-0000-0040	969	TALON PLACE
8	04-21-31-511-0000-0080	985	TALON PLACE
9	04-21-31-511-0000-0090	993	TALON PLACE
10	04-21-31-511-0000-0100	997	TALON PLACE
12	04-21-31-511-0000-0120	1005	TALON PLACE
13	04-21-31-511-0000-0130	1009	TALON PLACE
14	04-21-31-511-0000-0140	980	TALON PLACE
15	04-21-31-511-0000-0150	976	TALON PLACE
16	04-21-31-511-0000-0160	972	TALON PLACE
17	04-21-31-511-0000-0170	968	TALON PLACE
18	04-21-31-511-0000-0180	964	TALON PLACE
19	04-21-31-511-0000-0190	960	TALON PLACE
21	04-21-31-511-0000-0210	948	TALON PLACE
22	04-21-31-511-0000-0220	944	TALON PLACE
23	04-21-31-511-0000-0230	940	TALON PLACE
24	04-21-31-511-0000-0240	906	TALON PLACE
25	04-21-31-511-0000-0250	905	TALON PLACE
26	04-21-31-511-0000-0260	909	TALON PLACE
27	04-21-31-511-0000-0270	913	TALON PLACE
28	04-21-31-511-0000-0280	917	TALON PLACE
29	04-21-31-511-0000-0290	921	TALON PLACE
30	04-21-31-511-0000-0300	925	TALON PLACE
31	04-21-31-511-0000-0310	929	TALON PLACE
32	04-21-31-511-0000-0320	933	TALON PLACE
33	04-21-31-511-0000-0330	937	TALON PLACE
34	04-21-31-511-0000-0340	941	TALON PLACE
35	04-21-31-511-0000-0350	945	TALON PLACE

RECOMMENDATION:

Staff recommends the City Commission approve the Final Engineering Plans and Aesthetic Review for RaceTrac.

Mr. Brian Fields, P.E., Director, Community Development Department provided background information and an overview of the proposed project to the City Commission.

Mayor Lacey opened the “Public Input” portion of the Agenda Item.

No one spoke.

Mayor Lacey closed the “Public Input” portion of the Agenda Item.

“ITEM ‘400’, I WILL MAKE THE MOTION TO APPROVE.” MOTION BY COMMISSIONER RESNICK. SECONDED BY DEPUTY MAYOR CARROLL. DISCUSSION.

VOTE:

**DEPUTY MAYOR CARROLL: AYE
COMMISSIONER KENDRICK: AYE
COMMISSIONER RESNICK: AYE
COMMISSIONER HOVEY: AYE
COMMISSIONER CANNON: AYE
MOTION CARRIED.**

PUBLIC HEARINGS

401. Community Development Department

REQUEST:

The Community Development Department requests the City Commission hold a public hearing for the approval of 1) Final Engineering Plans; and 2) Waiver Request for Northern Oaks, a proposed 35-lot single-family residential subdivision located just east of the intersection of State Road 434 and State Road 417.

FISCAL IMPACT:

Approval of the Final Engineering Plan and Aesthetic Review allows the subject property to be developed into a single-family residential subdivision. Development of the subject property is anticipated to provide an increase to the City’s taxable value. The potential tax revenue of the proposed project is as follows:

- Fee Simple Single Family Residential Units - 35 units
- Units - 35 assessed at \$200,000 = \$7,000,000 assessed tax value
 - $\$10,800,000/1000 = 7,000$
 - $\$7,000.00 \times (2.4300) = \$17,010$
 - $\$17,010$ (less the 4% statutory discount) = \$16,329.60 tax revenue

COMMUNICATION EFFORTS:

This Agenda Item has been electronically forwarded to the Mayor and City Commission, City Manager, City Attorney/Staff, and is available on the City's Website, LaserFiche, and the City's Server. Additionally, portions of this Agenda Item are typed verbatim on the respective Meeting Agenda which has also been electronically forwarded to the individuals noted above, and which is also available on the City's Website, LaserFiche, and the City's Server; has been sent to applicable City Staff, Media/Press Representatives who have requested Agendas/Agenda Item information, Homeowner's Associations/Representatives on file with the City, and all individuals who have requested such information. This information has also been posted outside City Hall, posted inside City Hall with additional copies available for the General Public, and posted at six (6) different locations around the City. Furthermore, this information is also available to any individual requestors. City Staff is always willing to discuss this Agenda Item or any Agenda Item with any interested individuals.

RECOMMENDATION:

Staff recommends that the City Commission approve: 1) Final Engineering Plans, and 2) Waivers to Sections 20-186(2) and 20-186(3) of the Code of Ordinances for Northern Oaks.

This Agenda Item was introduced by Mr. Fields.

Deputy Mayor Pam Carroll asked about traffic signalization to help residents with ingress and egress out of this property.

Mr. Fields briefly addressed the process and how Seminole County would handle traffic timing and added, "I am sure they will address that."

Commissioner Cade Resnick asked about drainage issues. Mr. Fields explained what they are requiring of the home builder at the time of construction for this project. Furthermore, Mr. Fields remarked, "We've implemented the proper tools to address drainage on those very narrow size lots."

Commissioner Cannon asked about recent Quiet Title action. City Attorney Anthony A. Garganese noted that they have been provided with a copy of a Deed. Mr. Fields then commented, "We have the signed copy of a Deed that is being recorded any day now, as I understand it."

Mayor Lacey opened the "Public Input" portion of the Agenda Item.

No one spoke.

Mayor Lacey closed the "Public Input" portion of the Agenda Item.

"I MAKE A MOTION TO APPROVE ITEM '401.'" MOTION BY COMMISSIONER RESNICK. SECONDED BY COMMISSIONER CANNON. DISCUSSION.

VOTE:

COMMISSIONER HOVEY: AYE
COMMISSIONER CANNON: AYE
COMMISSIONER KENDRICK: AYE
COMMISSIONER RESNICK: AYE
DEPUTY MAYOR CARROLL: AYE
MOTION CARRIED.

With brief comments, Mr. Fields said, "On the Aesthetic Review, that will come back under a separate Public Hearing at a later date for City Commission approval."

❖❖ **AGENDA NOTE: THE FOLLOWING PUBLIC HEARINGS AGENDA ITEMS "402", "403", AND "404" WERE DISCUSSED SIMULTANEOUSLY, AS DOCUMENTED, FOLLOWED BY THE REST OF THE AGENDA. ❖❖**

PUBLIC HEARINGS AGENDA**PUBLIC HEARINGS****402. Community Development Department****REQUEST:**

The Community Development Department – Planning Division requests that the City Commission hold a Public Hearing to consider both a Small-Scale Future Land Use Map Amendment and a Rezoning for approximately 6.25 acres, generally located at 1379 State Road 434 as described within Ordinances 2017-02 and 2017-03.

FISCAL IMPACT:

The proposed Small-Scale future land use amendment, which re-designates the property from City of Winter Springs "Greenway Interchange District (GID)" with a "Conservation Overlay" to Winter Springs "Commercial" with a "Conservation Overlay," will increase the potential for additional taxable value to the City. The administrative Small Scale Plan Amendment is expected to increase the probability of future commercial and/or office development activity within this particular area.

COMMUNICATION EFFORTS:

This Agenda Item has been electronically forwarded to the Mayor and City Commission, City Manager, City Attorney/Staff, and is available on the City's Website, LaserFiche, and the City's Server. Additionally, portions of this Agenda Item are typed verbatim on the respective Meeting Agenda which has also been electronically forwarded to the individuals noted above, and which is also available on the City's Website, LaserFiche, and the City's Server; has been sent to applicable City Staff, Media/Press Representatives who have requested Agendas/Agenda Item information, Homeowner's Associations/Representatives on file with the City, and all individuals who have requested such information. This information has also been posted outside City Hall, posted inside City Hall with additional copies available for the General Public, and posted at six (6) different locations around the City. Furthermore, this information is also available to any individual requestors. City Staff is always willing to discuss this Agenda Item or any Agenda Item with any interested individuals.



1117 East Robinson St.
Orlando, FL 32801
Phone: 407.425.0452
Fax: 407.648.1036

October 2, 2019

Ms. Rachel Gironella
Civil Engineer
City of Winter Springs
1126 E SR 434
Winter Springs, FL 32708

RE: Northern Oaks - plan review
CPH project W04183

Dear Rachel,

We reviewed the permitted plans and storm water calculations we retrieved from the St. Johns River Water Management District (SJRWMD) to verify if the total impervious area per lot can be increased from 40% to 50%, maximum.

The calculations for the two wet ponds indicate there is more volume than required for the original design. We were able to verify the total impervious area for each lot and recalculated based on an additional 10% impervious area for each lot to determine a new total impervious area.

Based on our calculations, the ponds, as designed and permitted through the SJRWMD have sufficient capacity to allow the developer to increase the impervious area on each lot to 50% coverage.

We do not have any objections to the City approving the additional area for each lot, to a maximum of 50% for each lot.

Sincerely,
CPH, Inc.

A handwritten signature in black ink that reads "Allen C. Lane, Jr." in a cursive script.

Allen C. Lane, Jr., P.E.
Project Engineer

J:\W04183\Civil\1-City Plan Review\Northern Oaks\letter\ltr to City re impervious area.doc



REGULAR AGENDA ITEM 500

CITY COMMISSION AGENDA | NOVEMBER 18, 2019 | REGULAR MEETING

TITLE

Review Status of Winter Springs Retirement Residence, LLC Development Agreement - The City Commission should review the obligation contained in the Developer's Agreement, dated January 22, 2018, recorded in Seminole County Official Records Book 9105, Pages 264-276, to substantially commence construction of the development project within eighteen (18) months after the Agreement's recording and provide direction regarding a possible extension of the deadline or termination of the Agreement.

SUMMARY

On January 22, 2018, the City Commission held a public hearing and approved the Final Engineering, Aesthetic Review Plans, and Developer's Agreement for the Winter Springs Retirement Residence, LLC (Hawthorn ILF). The Special Exceptions for the Project were previously approved by the City Commission on June 8, 2015 and extended on July 10, 2017. The project is a proposed 4-story, 145-suite senior independent living facility located in the Town Center at the southeast corner of SR 434 and Michael Blake Boulevard.

Section 26.0 of the Development Agreement, titled "Termination," provides that the City shall have the unconditional right, but not obligation, to terminate the Agreement, without notice or penalty, if the Developer fails to receive building permits and substantially commence construction of the development project within eighteen (18) months after the Agreement is recorded in the public records of Seminole County. The term "substantially commence construction of the development project" was defined to mean the completion of lot clearing and surveying and substantial construction of infrastructure required to support any building improvements, but not vertical construction of any building improvements.

The Development Agreement was recorded on April 6, 2018. Accordingly, the deadline to substantially commence construction of the development project was October 6, 2019. In anticipation of the deadline approaching, the City Engineer and Engineer of Record for the project attempted to further refine what was meant by "infrastructure required to support any building improvements." They agreed in May or early June 2019 that the first six items listed in the Project's construction schedule would constitute "infrastructure required to support any building improvements" for purposes of the deadline. These items were:

- Demo Site Clearing/Erosion Control
- Site Grading – Pad Ready
- Storm Lines & Structures
- Sanitary Sewer
- Water Services
- Curb and Gutter

Presently, the site grading and curb and gutter are not completed.

It should also be noted that Winter Springs Retirement Residence notified the City on June 28, 2019, of its intent to exercise the right, pursuant to Section 252.363, Florida Statutes, to extend the October 6, 2019 deadline for a period of 420 days, plus (6) months, due to the Governor's series of Executive Orders declaring a state of emergency related to the opioid crisis. The City subsequently informed Winter Springs Retirement Residence that the extension would not be permitted in accordance with Florida law, specifically amendments made to Section 252.363, Florida Statutes, to require that tolling of deadlines be based on natural emergencies rather than man-made emergencies, which became effective the same day the notice was submitted to the City.

Winter Springs Retirement Residence has been notified via counsel that the City Commission would consider possible extension or termination of the Development Agreement pursuant to Section 26.0 at the November 18, 2019 City Commission meeting if the site grading (pad ready) and curb and gutter were not completed by that date.

RECOMMENDATION

The City Commission should review the obligation contained in the Developer's Agreement, dated January 22, 2018, recorded in Seminole County Official Records Book 9105, Pages 264-276, to substantially commence construction of the development project within eighteen (18) months after the Agreement's recording and provide direction regarding a possible extension of the deadline or termination of the Agreement.



GRANT MALDY, SEMINOLE COUNTY
 CLERK OF CIRCUIT COURT & COMPTROLLER
 BK 9105 Pgs 264-276 (13Pgs)
 CLERK'S # 2018037263
 RECORDED 04/06/2018 08:10:20 AM
 RECORDING FEES \$112.00
 RECORDED BY hdevore

THIS INSTRUMENT WAS PREPARED BY
 AND SHOULD BE RETURNED TO:

 Anthony Garganese
 City Attorney of Winter Springs
 Garganese, Weiss, D'Agresta & Salzman, P.A.
 111 N. Orange Avenue, Suite 2000
 Orlando, FL 32802
 (407) 425-9566

FOR RECORDING DEPARTMENT USE ONLY

DEVELOPER'S AGREEMENT

THIS DEVELOPER'S AGREEMENT (the "Agreement") is made and executed this 22nd day of January, 2018 by and between the **CITY OF WINTER SPRINGS**, a Florida Municipal Corporation (the "City"), whose address is 1126 East S.R. 434, Winter Springs, Florida 32708, and **WINTER SPRINGS RETIREMENT RESIDENCE LLC**, a Washington limited liability company ("Developer"), whose address is 9310 NE Vancouver Mall Drive, Suite 200, Vancouver, Washington 98662.

WITNESSETH:

WHEREAS, this Agreement is related to certain real property located in Seminole County, Florida, on the south side of East State Road 434 adjacent to the Cross Seminole Trail Bridge, Winter Springs, Florida, being a part of tax parcel identification number 26-20-30-5AR-0A00-008H, and more particularly legally described on **EXHIBIT "A"**, which is hereby fully incorporated herein by this reference (the "**Property**"); and

WHEREAS, the Property is currently designated Town Center on the City's Zoning Map and Future Land Use Map with a T5 transect designation; and

WHEREAS, the Developer desires to purchase the Property and construct a 145 unit adult congregate living facility, as more specifically described herein; and

WHEREAS, in furtherance of this desire, the Developer has obtained four special exceptions for an adult congregate living facility, as initially approved by the City Commission on June 8, 2015, which approvals have been extended in accordance with this Agreement, and has also filed with the City several development permit applications seeking approval of final engineering plans and aesthetic review for the proposed adult congregate living facility which is generally described above; and

WHEREAS, in furtherance of the special exceptions and development unique to the Project (defined in Section 4.0 below), the City Commission desires to now approve the pending final engineering and aesthetic review applications which were specifically submitted by the

Developer and to address other development related issues, all pursuant to the terms and conditions set forth under this Agreement; and

NOW THEREFORE, in consideration of the mutual promises and covenants contained herein, the parties mutually agree as follows:

1.0 Recitals; Effective Date. The foregoing recitals are true and correct and are hereby incorporated herein by this reference. The Effective Date of this Agreement shall be the date on which the last party hereto timely and fully executes this Agreement ("**Effective Date**"), subject to the terms of Section 14.0 below.

2.0 Authority. This Agreement is entered into pursuant to the Florida Municipal Home Rule Powers Act.

3.0 Acquisition of Property. Developer anticipates purchasing the Property within one (1) year of the Effective Date of this Agreement. Developer may request a three (3) month extension of this time period upon written request to the City. The extension will not be unreasonably withheld for good cause shown by the Developer. If Developer fails to complete the purchase within said time period (as may be extended by the City), this Agreement shall automatically be deemed null and void and terminated. Upon closing on the Property, the Developer shall promptly provide written notice of said closing to the City no later than two (2) business days after closing so the City can record this Agreement pursuant to Section 15 of this Agreement.

4.0 Project Description. Upon purchase of the Property, the City and Developer agree that the Property shall be developed as an adult congregate living facility, intended and operated for occupancy by persons 55 years of age or older subject to safe harbor provisions under law (commonly referred to, without limitation, as "Housing for Older Persons" under Title VIII of the Civil Rights Act of 1968, as amended by the Fair Housing Amendments Act of 1988, as further amended by the Housing for Older Persons Act of 1995, 42 U.S.C. Section 3601, *et. seq.*, as may be further amended, and under Florida's Fair Housing Act, Florida Statute Section 760.20 (2017), *et. seq.*, as may be amended), consisting of a maximum of 145 separate rentable units, operations related manager unit and separate co-manager unit, and common amenities (collectively, the "**Project**"). Development of the Property shall be in conformance with applicable law and the Preliminary/Final Site Plan Winter Springs Retirement Residence prepared by Tillman & Associates, Inc., dated December 8, 2017, and approved by the City Commission on January 22, 2018 ("**Final Engineering Plans**") and Aesthetic Review Package submitted to the City by the Developer and approved by the City Commission on January 22, 2018 (collectively, "**Development Plans**"). A true and exact copy of the Development Plans, as may be amended from time to time pursuant to the Winter Springs City Code ("**City Code**"), shall be maintained at City Hall and shall hereby be deemed fully incorporated herein by this reference. Once Development Plans, individually or collectively, are amended in accordance with City Code, should amendments ever occur, the Development Plans as amended shall control over any conflict with the terms of this Agreement. For purposes of clarity, amendments to the Development Plans pursuant to City Code shall not require an amendment to this Agreement.

5.0 Utilities.

The City confirms that as of the Effective Date of this Agreement, sufficient plant capacity exists to service the Project with water and sewer service. The Project, if developed in accordance with the applicable provisions of the City Comprehensive Plan, City Code and this Agreement, satisfies and is fully vested against concurrency requirements for sewer, potable water, reclaimed water and transportation as described in the City Code and Comprehensive Plan.

6.0 Additional Development Conditions. Development of the Property shall also be subject to the following additional conditions:

A. *Reimbursement of Waterline Across SR 434.* Concurrently with the construction of the Project by the Developer, the City has requested and the Developer agrees to construct a water line which will be extended from the south side of S.R. 434 to the north side of S.R. 434 as depicted on the Final Engineering Plans. Upon completion and acceptance by the City, the Developer shall convey the water main to the City by bill of sale. Acceptance by the City shall not be unreasonably withheld or delayed. The City shall reimburse the Developer all costs and expenses incurred by the Developer in the design, engineering, permitting and construction of the water line, not to exceed \$ 40,000.00 within a reasonable time after City's acceptance of the same, not to exceed thirty (30) days.

B. *Lift Station.* Developer shall be required to construct a lift station facility on the portion of the Property identified on the Final Engineering Plans at the Developer's expense. Upon completion and final acceptance by the City, the lift station facility shall be conveyed to the City by bill of sale and the City agrees to maintain the facilities in perpetuity. However, the portion of Property on which the lift station facility is constructed shall remain owned by the Developer. Acceptance by the City shall not be unreasonably withheld or delayed. The Developer shall grant the City a lift station easement in a form reasonably acceptable to the City Attorney.

C. *Stormwater Facilities.* All stormwater facilities shall be constructed by Developer for the Project on the Property at the Developer's expense. The stormwater facilities shall be owned and maintained in perpetuity by the then present owner of the Property. However, the Developer shall grant the City an emergency access and maintenance easement upon all stormwater ponds and areas which grants the City the right to conduct inspections and emergency operation and maintenance. The easement shall be prepared in a form reasonably acceptable to the City Attorney.

D. *Dedication of Michael Blake Boulevard Extension.* Developer shall be required to construct the extension of Michael Blake Boulevard, at its expense, as reflected on the Final Engineering Plans ("Roadway Improvements"). This right-of-way shall be dedicated to the City in a form reasonably acceptable to the City Attorney and within a reasonable time of the City requesting the dedication in writing. If such dedication is requested before construction has been completed, the City agrees to grant Developer a use agreement to complete construction of the improvements in the right of way. After completion of the construction of this right-of-way substantially in accordance with the Final Engineering Plans, as certified by a registered Florida

professional engineer, request shall be made by Developer to the City Commission for acceptance of the roadway construction, which acceptance shall not be unreasonably withheld or delayed. All such land conveyances shall be by a recorded deed and be free and clear of all encumbrances that would prohibit use of the same as a public road. Conveyance of improvements shall be by bill of sale and free and clear of all liens that would prohibit use of the improvements for their intended purposes. The deed of conveyance (as the case may be) and bill of sale shall be in a form reasonably acceptable to the City Attorney.

E. **Conveyances.** The City acknowledges and agrees that the conveyances of the Roadway Improvements and utilities are being conveyed for a public purpose and necessity (in lieu of condemnation) and, accordingly, such conveyances are exempt from documentary stamp taxes. The City shall be responsible for all closing costs, except that the Developer shall be responsible for any costs related to clearing or remedying any defects of title or encumbrances that prohibit use of the roadway as public road and improvements for their intended purposes.

7.0 **Offsite Improvements/Contribution of Lands.** The City and Developer agree that all required onsite and offsite improvements are shown on the Final Engineering Plans.

8.0 **Representations of the Parties.** The City and Developer hereby each represent and warrant to the other that it has the power and authority to execute, deliver and perform the terms and provisions of this Agreement and has taken all necessary action to authorize the execution, delivery and performance of this Agreement. This Agreement will, when duly executed and delivered by the City and Developer and recorded in the Public Records of Seminole County, Florida, constitute a legal, valid and binding obligation enforceable against the parties hereto, and when recorded as permitted by this Agreement, against the Property in accordance with the terms and conditions of this Agreement. Developer represents that it has voluntarily and willfully executed this Agreement for purposes of binding the Property to the terms and conditions set forth in this Agreement.

9.0 **Successors and Assigns.** Upon being recorded in the Public Records of Seminole County, Florida, this Agreement shall automatically be binding upon and shall inure to the benefit of the City and Developer and their respective successors and assigns. The terms and conditions of this Agreement similarly shall be binding upon the Property and shall run with title to the same.

10.0 **Applicable Law; Venue.** This Agreement shall be governed by and construed in accordance with the laws of the State of Florida. The parties agree that venue shall be exclusively in Seminole County, Florida, for all state disputes or actions which arise out of or are based upon this Agreement, and in Orlando, Florida, for all federal disputes or actions which arise out of or are based upon this Agreement.

11.0 **Amendments.** This Agreement shall not be modified or amended except by written agreement duly executed by both parties hereto (or their successors or assigns) and approved by the City Commission.

12.0 **Entire Agreement; Exhibits.** This Agreement and all attached exhibits hereto supersedes any other agreement, oral or written, regarding the Property and contains the entire

agreement between the City and Developer as to the subject matter hereof. The Exhibits attached hereto and referenced herein are hereby fully incorporated herein by this reference.

13.0 Severability. If any provision of this Agreement shall be held to be invalid or unenforceable to any extent by a court of competent jurisdiction, the same shall not affect in any respect the validity or enforceability of the remainder of this Agreement.

14.0 Execution of Agreement; Effective Date; Escrow Pending Recordation. This Agreement shall be fully executed by the parties no later than sixty (60) days after it is approved by the City Commission. This Agreement shall become effective upon approval by the City Commission and execution of this Agreement by both parties hereto. Upon execution of this Agreement by the parties, the term of the four special exceptions obtained by the Developer for an adult congregate living facility, as initially approved by the City Commission on June 8, 2015, are hereby extended to coincide with the term of this Agreement. Pending the Developer's closing on the Property and recordation of this Agreement pursuant to Section 15.0 of this Agreement, the City Attorney shall hold the fully executed, original Agreement in escrow on behalf of the Parties until such time the Agreement is required to be recorded pursuant to Section 15.0.

15.0 Recordation. At such time Developer notifies the City that it has closed on the Property, as contemplated by Section 3.0 of this Agreement, this Agreement shall be recorded, without further notice or consent of the Parties, by the City Attorney in the Public Records of Seminole County, Florida, and said Agreement shall then run with and be binding upon the Property. This Agreement shall not be recorded unless Developer closes on the acquisition of the Property.

16.0 Joinders of Mortgage Holders. To the extent applicable, the Developer shall be required to obtain a written joinder from all mortgage holders that may have a recorded mortgage upon the Property prior to the date that this Agreement is recorded on the Property. The joinder shall be in recordable form and shall evidence the mortgage holder's consent that the terms and conditions of this Agreement shall survive any foreclosure of their respective mortgage recorded against the Property. A copy of the recorded joinder shall be promptly delivered to the City upon recordation or upon request by the City.

17.0 Relationship of the Parties. The relationship of the parties to this Agreement is contractual and Developer is an independent contractor and not an agent of the City. Nothing herein shall be deemed to create a joint venture or principal-agent relationship between the parties, and neither party is authorized to, nor shall either party act toward third persons or the public in any manner, which would indicate any such relationship with the other.

18.0 Sovereign Immunity. Notwithstanding any other provision set forth in this Agreement, nothing contained in this Agreement shall be construed as a waiver of the City's right to sovereign immunity under Section 768.28, or other limitations imposed on the City's potential liability under state or federal law. As such, the City shall not be liable, under this Agreement for punitive damages or interest for the period before judgment. Further, the City shall not be liable for any claim or judgment, or portion thereof, to any one person for more than two hundred thousand dollars (\$200,000.00), or any claim or judgment, or portion thereof,

which, when totaled with all other claims or judgments paid by the State or its agencies and subdivisions arising out of the same incident or occurrence, exceeds the sum of three hundred thousand dollars (\$300,000.00).

19.0 City's Police Power. Developer agrees and acknowledges that the City hereby reserves all police powers granted to the City by law. In no way shall this Agreement be construed as the City bargaining away or surrendering its police powers.

20.0 Interpretation. The parties hereby agree and acknowledge that they have both participated equally in the drafting of this Agreement and no party shall be favored or disfavored regarding the interpretation to this Agreement in the event of a dispute between the parties.

21.0 Third-Party Rights. This Agreement is not a third-party beneficiary contract and shall not in any way whatsoever create any rights on behalf of any third party.

22.0 Specific Performance. Strict compliance shall be required with each and every provision of this Agreement. The parties agree that failure to perform the obligations provided by this Agreement shall result in irreparable damage and that specific performance of these obligations may be obtained by a suit in equity.

23.0 Attorney's Fees. In connection with any arbitration or litigation arising out of this Agreement, each party agrees to bear their own attorney's fees and costs.

24.0 Development Permits. Nothing herein shall limit the City's authority to grant or deny any development permit applications or requests subsequent to the Effective Date of this Agreement. The failure of this Agreement to address any particular City, County, State and/or Federal permit, condition, term or restriction shall not relieve Developer or the City of the necessity of complying with the law governing said permitting requirement, condition, term or restriction. Without imposing any limitation on the City's police powers, the City reserves the right to withhold, suspend, or terminate any and all certificates of occupancy for any building or unit if Developer is in material breach of any term and condition of this Agreement until the material breach is cured.

25.0 Default; Opportunity to Cure. Should either party desire to declare the other party in default of any term and condition of this Agreement, the non-defaulting party shall provide the defaulting party a written notice of default. The written notice shall, at a minimum, state with particularity the nature of the default, the manner in which the default can be cured, and a reasonable time period of not less than thirty (30) days in which the default must be cured. No action may be taken in a court of law on the basis that a breach of this Agreement has occurred until such time as the requirements of this paragraph have been satisfied.

26.0 Termination. The Developer acknowledges and agrees that the Development Plans and this Agreement were approved by the City Commission based on conditions that existed upon the Effective Date. As such, the City shall have the unconditional right, but not obligation, to terminate this Agreement, without notice or penalty, if Developer fails to receive building permits and substantially commence construction of the development project within eighteen (18) months after this Agreement is recorded in the public records of Seminole County

as required by Section 15.0 of this Agreement. The term "substantially commence construction of the development project" means completion of lot clearing and surveying and substantial construction of infrastructure required to support any building improvements, but not vertical construction of any building improvements. In addition, the City shall have the right, but not obligation, to terminate the Agreement if Developer permanently abandons construction of the development project, provided, however, the City shall first deliver written notice and an opportunity to cure as set forth in Paragraph 25.0 herein. If the City terminates this Agreement, the City shall record a notice of termination in the public records of Seminole County, Florida.

27.0 Notices. Any notice required or allowed to be delivered hereunder shall be in writing and shall be deemed to be delivered when: (a) hand delivered to the official hereinafter designated, or (b) upon receipt of such notice, when deposited in the United States mail, postage prepaid, certified or registered mail, return receipt requested, or (c) one day after deposit with a nationally recognized overnight courier services, e.g. Federal Express, United Parcel Service, Airborne, Express Mail, etc., addressed to a party at the other address specified below or from time to time by written notice to the other party delivered in accordance herewith.

Developer Winter Springs Retirement Residence LLC
 9310 NE Vancouver Mall Dr.
 Suite 2000
 Vancouver, WA 98662
 Attn: R. GAINS

With copy to: Charles B. Costar, III, Esq.
 Shutts & Bowen LLP
 300 South Orange Avenue
 Suite 1600
 Orlando, FL 32801
 (407) 423-3200

City: Kevin Smith
 City Manager
 City of Winter Springs
 1126 East State Road 434
 Winter Springs, FL 32708
 Telephone: (407) 327-5957
 Fax: (407) 327-4753

With a copy to: Anthony A. Garganese, Esq.
 Garganese, Weiss, D'Agresta & Salzman, P.A.
 111 N. Orange Avenue, Suite 2000
 Orlando, FL 32801
 Phone: (407) 425-9566
 Fax: (407) 425-9596

28.0 Force Majeure. The parties agree that in the event that the failure by either party to accomplish any action required hereunder within a specified time period ("Time Period") constitutes a default under the terms of this Agreement and, if any such failure is due to any unforeseeable or unpredictable event or condition beyond the control of such party, including, but not limited to, acts of God, acts of government authority (other than the City's own acts as to a claim by the City for force majeure), acts of public enemy or war, riots, civil disturbances, power failure, shortages of labor or materials, injunction or other court proceedings beyond the control of such party, or severe adverse weather conditions ("Uncontrollable Event"), then, notwithstanding any provision of this Agreement to the contrary, that failure shall not constitute a default under this Agreement and any Time Period proscribed hereunder shall be extended by the amount of time that such party was unable to perform solely due to the Uncontrollable Event. The extended time period shall be agreed to in writing by the parties and said agreement shall not be unreasonably withheld by either party.

IN WITNESS WHEREOF, the parties have hereunto set their hands and seal on the date first above written.

CITY OF WINTER SPRINGS

By: 
Charles Lacey, Mayor

ATTEST:

By: 
Andrea Lorenzo Luaces, City Clerk

APPROVED AS TO FORM AND LEGALITY
For the use and reliance of the City of Winter Springs,
Florida only.

Date: 2/13/18

By: 
Anthony A. Garganese, City Attorney for
the City of Winter Springs, Florida

CITY SEAL

Signed, sealed and delivered in the presence of the following witnesses:

[Signature]
Signature of Witness
KEVIN J SWANSON
Printed Name of Witness

[Signature]
Signature of Witness
JAMIE COBB
Printed Name of Witness

WINTER SPRINGS RETIREMENT RESIDENCE LLC, a Washington limited liability company

By: Hawthorn IL Propco LP, a Delaware limited partnership, its manager

By: CP HRG IL REIT, LLC, its sole general partner

By: [Signature]
Name: Alan Spragins
Date: Chief Operating Officer

STATE OF Washington
COUNTY OF King

The foregoing instrument was acknowledged before me this 26 day of January, 2018, Alan Spragins, as Chief Operating Officer of CP HRG IL REIT, LLC, sole general partner of Hawthorn IL Propco LP, a Delaware limited partnership, manager of **Winter Springs Retirement Residence LLC** a Washington limited liability company, on behalf of said company. He is personally known to me or produced _____ as identification.

(NOTARY SEAL)



[Signature]
(Notary Public Signature)
Yasamine Firoozi
(Print Name)
Notary Public, State of Washington
Commission No.: 186605
My Commission Expires: July 30, 2020

DEVELOPER IS HEREBY ADVISED THAT SHOULD DEVELOPER FAIL TO FULLY EXECUTE, AND DELIVER TO THE CITY, THIS AGREEMENT WITHIN SIXTY (60) DAYS FROM THE DATE THAT THE CITY COMMISSION APPROVES THIS AGREEMENT, THIS AGREEMENT, AND THE DEVELOPMENT PERMIT APPROVALS REFERENCED HEREUNDER, SHALL AUTOMATICALLY BE DEEMED NULL AND VOID.

EXHIBIT "A"

Parcel 1:

THAT PART OF LOT 8 BLOCK "A", D.R. MITCHELL'S SURVEY OF THE LEVY GRANT AS RECORDED IN PLAT BOOK 1, PAGE 5 OF THE PUBLIC RECORDS OF SEMINOLE COUNTY, FLORIDA BEING MORE PARTICULARLY DESCRIBED AS FOLLOWS:

COMMENCE AT THE SOUTHWESTERN MOST CORNER OF LOT 31 ST. JOHNS LANDING AS RECORDED IN PLAT BOOK 53, PAGES 45 THRU 49 OF SAID PUBLIC RECORDS, SAID POINT BEING A RECOVERED CONCRETE MONUMENT ON THE EASTERLY RIGHT OF WAY LINE OF TUSKAWILLA ROAD (FORMERLY BRANTLEY AVENUE) AS RECORDED IN OFFICIAL RECORDS BOOK 3225, PAGE 1829 OF SAID PUBLIC RECORDS; THENCE RUN NORTH 59°31'38" WEST ALONG THE WESTERLY PROLONGATION OF THE SOUTH LINE OF SAID LOT 31 FOR A DISTANCE OF 15.00 FEET; THENCE RUN SOUTH 30°04'55" WEST ALONG SAID EASTERLY RIGHT OF WAY LINE FOR A DISTANCE OF 5.00 FEET; THENCE CONTINUE SOUTH 30°04'55" WEST A DISTANCE OF 35.00 FEET; THENCE S 59°31'38" E, A DISTANCE OF 1132.34 FEET TO THE POINT OF CURVATURE OF A CURVE TO THE RIGHT HAVING A RADIUS OF 150.00 FEET; THENCE RUN SOUTHEASTERLY ALONG THE ARC OF SAID CURVE THROUGH A CENTRAL ANGLE AT 60°36'00" FOR AN ARC DISTANCE OF 158.65 FEET TO THE POINT OF TANGENCY; THENCE SOUTH 01°04'22" WEST A DISTANCE AT 146.91 FEET; THENCE SOUTH 24°59'41"W, A DISTANCE OF 318.72 FEET; THENCE SOUTH 00°00'00" EAST A DISTANCE OF 115.48 FEET; THENCE SOUTH 36°55'21" EAST A DISTANCE OF 217.54 FEET; THENCE SOUTH 15°19'53" EAST A DISTANCE OF 140.49 FEET; THENCE SOUTH 02°23'00 WEST A DISTANCE OF 556.34 FEET; THENCE SOUTH 07°25'15" WEST A DISTANCE OF 272.61 FEET; THENCE SOUTH 29°30'05" WEST A DISTANCE OF 231.32 FEET; THENCE SOUTH 50°31'58" WEST A DISTANCE OF 1475.69 FEET TO THE NORTHEASTERLY RIGHT OF WAY LINE OF STATE ROAD 434 ACCORDING TO FLORIDA DEPARTMENT OF TRANSPORTATION RIGHT OF WAY MAP SECTION 77070-2516; THENCE CONTINUE SOUTH 50°31'58" WEST FOR A DISTANCE OF 143.34 FEET TO A FOUND 1/2" IRON ROD & CAP (LB 6723) AND THE SOUTHWESTERLY RIGHT OF WAY LINE OF SAID STATE ROAD 434, ALSO BEING THE POINT OF BEGINNING; THENCE ALONG THE NORTHERLY BOUNDARY OF ACQUISITION PARCEL "A" AS DESCRIBED IN OFFICIAL RECORDS BOOK 3988, PAGE 1075 OF THE PUBLIC RECORDS OF SEMINOLE COUNTY, FLORIDA, SOUTH 49°30'36" WEST FOR A DISTANCE OF 316.60 FEET TO A FOUND 4"X4" CONCRETE MONUMENT (LB 6723) AND TO THE SOUTHWESTERLY CORNER OF LANDS DESCRIBED IN EXHIBIT "A" (SWAP PARCEL 1) AS DESCRIBED IN OFFICIAL RECORDS BOOK 8856, PAGE 546 OF THE PUBLIC RECORDS OF SEMINOLE COUNTY, FLORIDA; THENCE DEPARTING SAID NORTHERLY BOUNDARY, ALONG THE WESTERLY BOUNDARY OF SAID LANDS AND ALONG THE EASTERLY BOUNDARY OF LANDS DESCRIBED IN EXHIBIT "A" (SWAP PARCEL 2) AS DESCRIBED IN OFFICIAL RECORDS BOOK 8856, PAGE 553 OF THE PUBLIC RECORDS OF SEMINOLE COUNTY, FLORIDA, NORTH 39°47'59" WEST, A DISTANCE OF 659.32 FEET TO A FOUND 4"X4" CONCRETE MONUMENT (LB 6723) AND THE

WESTERLY RIGHT OF WAY OF THE C.S.X. TRANSPORTATION INC. "LAKE CHARM BRANCH" RAIL CORRIDOR; SAID POINT BEING A NON TANGENT CURVE CONCAVE NORTHEASTERLY, HAVING A RADIUS OF 3707.33 FEET, AND A CHORD BEARING AND DISTANCE OF NORTH 03°26'01" WEST, 73.37 FEET; THENCE NORTHWESTERLY ALONG THE ARC OF SAID CURVE, AND SAID WESTERLY RIGHT OF WAY, THROUGH A CENTRAL ANGLE OF 01°08'02" FOR A DISTANCE OF 73.37 FEET TO A SET 5/8" IRON ROD AND CAP (LB 8071) AND THE END OF SAID CURVE; THENCE DEPARTING SAID WESTERLY RIGHT OF WAY, ALONG A CURVE CONCAVE NORTHERLY, HAVING A RADIUS OF 230.00 FEET, AND A CHORD BEARING AND DISTANCE OF NORTH 70°02'34" EAST, 93.83 FEET; THENCE NORTHEASTERLY ALONG THE ARC OF SAID CURVE, THROUGH A CENTRAL ANGLE OF 23°32'22" FOR A DISTANCE OF 94.49 FEET TO A SET 5/8" IRON ROD AND CAP (LB 8071) AND THE END OF SAID CURVE; THENCE NORTH 59°43'13" EAST, A DISTANCE OF 75.01 FEET TO A SET 5/8" IRON ROD AND CAP (LB 8071); THENCE NORTH 50°22'25" EAST, A DISTANCE OF 111.00 FEET TO A SET 5/8" IRON ROD AND CAP (LB 8071) AND TO THE AFORESAID SOUTHWESTERLY RIGHT OF WAY OF SAID STATE ROAD 434; THENCE ALONG SAID SOUTHWESTERLY RIGHT OF WAY, SOUTH 39°47'08" EAST, A DISTANCE OF 669.99 FEET TO THE POINT OF BEGINNING.

Parcel 2:

THAT PART OF LOT 8 BLOCK "A", OF TUSKAWILLA, ACCORDING TO THE PLAT OF D.R. MITCHELL'S SURVEY OF THE LEVY GRANT AS RECORDED IN PLAT BOOK 1, PAGE 5 OF THE PUBLIC RECORDS OF SEMINOLE COUNTY, FLORIDA BEING MORE PARTICULARLY DESCRIBED AS FOLLOWS:

COMMENCE AT THE SOUTHWESTERN MOST CORNER OF LOT 31 ST. JOHNS LANDING AS RECORDED IN PLAT BOOK 53, PAGES 45 THRU 49 OF SAID PUBLIC RECORDS, SAID POINT BEING A RECOVERED CONCRETE MONUMENT ON THE EASTERLY RIGHT OF WAY LINE OF TUSKAWILLA ROAD (FORMERLY BRANTLEY AVENUE) AS RECORDED IN OFFICIAL RECORDS BOOK 3225, PAGE 1829 OF SAID PUBLIC RECORDS; THENCE RUN NORTH 59°31'38" WEST ALONG THE WESTERLY PROLONGATION OF THE SOUTH LINE OF SAID LOT 31 FOR A DISTANCE OF 15.00 FEET; THENCE RUN SOUTH 30°04'55" WEST ALONG SAID EASTERLY RIGHT OF WAY LINE FOR A DISTANCE OF 5.00 FEET; THENCE CONTINUE SOUTH 30°04'55" WEST A DISTANCE OF 35.00 FEET; THENCE SOUTH 59°31'38" EAST, A DISTANCE OF 1132.34 FEET TO THE POINT OF CURVATURE OF A CURVE TO THE RIGHT HAVING A RADIUS OF 150.00 FEET; THENCE RUN SOUTHEASTERLY ALONG THE ARC OF SAID CURVE THROUGH A CENTRAL ANGLE AT 60°36'00" FOR AN ARC DISTANCE OF 158.65 FEET TO THE POINT OF TANGENCY; THENCE SOUTH 01°04'22" WEST A DISTANCE AT 146.91 FEET; THENCE SOUTH 24°59'41" WEST, A DISTANCE OF 318.72 FEET; THENCE SOUTH 00°00'00" EAST A DISTANCE OF 115.48 FEET; THENCE SOUTH 36°55'21" EAST A DISTANCE OF 217.54 FEET; THENCE SOUTH 15°19'53" EAST A DISTANCE OF 140.49 FEET; THENCE SOUTH 02°23'00" WEST A DISTANCE OF 556.34 FEET; THENCE SOUTH 07°25'15" WEST A DISTANCE OF 272.61 FEET; THENCE SOUTH 29°30'05" WEST A DISTANCE OF 231.32 FEET; THENCE SOUTH 50°31'58" WEST

A DISTANCE OF 1475.69 FEET TO THE NORTHEASTERLY RIGHT OF WAY LINE OF STATE ROAD 434 ACCORDING TO FLORIDA DEPARTMENT OF TRANSPORTATION RIGHT OF WAY MAP SECTION 77070-2516; THENCE CONTINUE SOUTH 50°31'58" WEST FOR A DISTANCE OF 143.34 FEET TO A FOUND 1/2" IRON ROD & CAP (LB 6723) AND THE SOUTHWESTERLY RIGHT OF WAY LINE OF SAID STATE ROAD 434; THENCE ALONG THE NORTHERLY BOUNDARY OF ACQUISITION PARCEL "A" AS DESCRIBED IN OFFICIAL RECORDS BOOK 3988, PAGE 1075 OF THE PUBLIC RECORDS OF SEMINOLE COUNTY, FLORIDA, SOUTH 49°30'36" WEST FOR A DISTANCE OF 316.60 FEET TO A FOUND 4"X4" CONCRETE MONUMENT (LB 6723) AND TO THE SOUTHWESTERLY CORNER OF LANDS DESCRIBED IN EXHIBIT "A" (SWAP PARCEL 1) AS DESCRIBED IN OFFICIAL RECORDS BOOK 8856, PAGE 546 OF THE PUBLIC RECORDS OF SEMINOLE COUNTY, FLORIDA; THENCE DEPARTING SAID NORTHERLY BOUNDARY, ALONG THE WESTERLY BOUNDARY OF SAID LANDS AND ALONG THE EASTERLY BOUNDARY OF LANDS DESCRIBED IN EXHIBIT "A" (SWAP PARCEL 2) AS DESCRIBED IN OFFICIAL RECORDS BOOK 8856, PAGE 553 OF THE PUBLIC RECORDS OF SEMINOLE COUNTY, FLORIDA, NORTH 39°47'59" WEST, A DISTANCE OF 659.32 FEET TO A FOUND 4"X4" CONCRETE MONUMENT (LB 6723) AND THE WESTERLY RIGHT OF WAY OF THE C.S.X. TRANSPORTATION INC. "LAKE CHARM BRANCH" RAIL CORRIDOR; SAID POINT BEING A NON TANGENT CURVE CONCAVE NORTHEASTERLY, HAVING A RADIUS OF 3707.33 FEET, AND A CHORD BEARING AND DISTANCE OF NORTH 03°26'01" WEST, 73.37 FEET; THENCE NORTHWESTERLY ALONG THE ARC OF SAID CURVE, AND SAID WESTERLY RIGHT OF WAY, THROUGH A CENTRAL ANGLE OF 01°08'02" FOR A DISTANCE OF 73.37 FEET TO A SET 5/8" IRON ROD AND CAP (LB 8071) AND THE POINT OF BEGINNING; THENCE CONTINUE ALONG SAID NON TANGENT CURVE CONCAVE NORTHEASTERLY, HAVING A RADIUS OF 3707.33 FEET, AND A CHORD BEARING AND DISTANCE OF NORTH 02°20'00" WEST, 29.41 FEET; THENCE NORTHWESTERLY ALONG THE ARC OF SAID CURVE, AND SAID WESTERLY RIGHT OF WAY, THROUGH A CENTRAL ANGLE OF 00°27'17" FOR A DISTANCE OF 29.42 FEET TO A FOUND 4"X4" CONCRETE MONUMENT (LB 220) ON THE EASTERLY EXTENSION OF THE NORTH LINE OF LOT 17 OF SAID PLAT OF D.R. MITCHELL'S SURVEY OF LEVY GRANT; THENCE CONTINUE ALONG SAID NON-TANGENT CURVE CONCAVE NORTHEASTERLY, HAVING A RADIUS OF 3707.33 FEET, AND A CHORD BEARING AND DISTANCE OF NORTH 01°55'26" WEST, 31.04 FEET; THENCE NORTHWESTERLY ALONG THE ARC OF SAID CURVE, AND SAID WESTERLY RIGHT OF WAY, THROUGH A CENTRAL ANGLE OF 00°28'47" FOR A DISTANCE OF 31.04 FEET TO A SET 5/8" IRON ROD AND CAP (LB 8071), SAID POINT BEING ON A NON TANGENT CURVE CONCAVE NORTHEASTERLY, HAVING A RADIUS OF 170.00 FEET, AND A CHORD BEARING AND DISTANCE OF NORTH 68°52'35" EAST, 63.61 FEET; THENCE NORTHEASTERLY ALONG THE ARC OF SAID CURVE, THROUGH A CENTRAL ANGLE OF 21°33'57" FOR A DISTANCE OF 63.99 FEET TO A SET 5/8" IRON ROD AND CAP (LB 8071) AND TO THE END OF SAID CURVE; THENCE NORTH 49°13'20" EAST, A DISTANCE OF 22.84 FEET TO A SET 5/8" IRON ROD AND CAP (LB 8071); THENCE NORTH 50°22'25" EAST, A DISTANCE OF 153.21 FEET TO THE AFORESAID SOUTHWESTERLY RIGHT OF WAY OF SAID STATE ROAD 434; THENCE ALONG SAID SOUTHWESTERLY RIGHT OF WAY, SOUTH 39°47'08" EAST, A

DISTANCE OF 72.00 FEET TO A SET 5/8" IRON ROD AND CAP (LB 8071); THENCE SOUTH 50°22'25" WEST, A DISTANCE OF 111.00 FEET TO A SET 5/8" IRON ROD AND CAP (LB 8071); THENCE SOUTH 59°43'13" WEST, A DISTANCE OF 75.01 FEET TO A SET 5/8" IRON ROD AND CAP (LB 8071), SAID POINT BEING THE BEGINNING OF A NON TANGENT CURVE CONCAVE NORTHEASTERLY, HAVING A RADIUS OF 230.00 FEET, AND A CHORD BEARING AND DISTANCE OF SOUTH 70°02'34" WEST, 93.83 FEET; THENCE SOUTHWESTERLY ALONG THE ARC OF SAID CURVE, THROUGH A CENTRAL ANGLE OF 23°32'22" FOR A DISTANCE OF 94.49 FEET TO THE POINT OF BEGINNING.



REGULAR AGENDA ITEM 501

CITY COMMISSION AGENDA | NOVEMBER 18, 2019 | REGULAR MEETING

TITLE

Waste Pro Contract Extension

SUMMARY

The Finance and Public Works Departments request that the City Commission receive the results of the Seminole County solid waste cost survey and extend the term of the existing Solid Waste Agreement with Waste Pro of Florida, Inc. for one year effective March 1, 2020.

On February 25, 2019, Ordinance 2019-04 was approved, which renewed the existing solid waste franchise with Waste Pro of Florida, Inc. by extending the term for one year effective March 1, 2019 with an option for the City to extend an additional one year. Pursuant to Ordinance No. 2006-001, as amended by Ordinance No. 2010-24 and Ordinance No. 2019-04, Waste Pro has been providing Solid Waste Services within the municipal boundaries of the City of Winter Springs since 2006 in accordance with the Solid Waste Agreement adopted by said Ordinances (“Existing Franchise Agreement”).

In recent weeks, we conducted a solid waste cost survey (Attachment A) of all Seminole County municipalities as well as Unincorporated Seminole County. As you will see from the attachment, not every agency has the same service frequency nor utilizes the same collection method. All but two of the respondents have the same pick-up frequency as the City of Winter Springs, which includes two garbage pick-ups, one recycling pick-up, and one yard waste pick-up each week. Lake Mary and Oviedo only offer one garbage pick-up per week. Casselberry and Unincorporated Seminole County pay the lowest collection rate; however, their collection is manual, and they do not provide the residents with garbage cans. Furthermore, Casselberry limits the garbage can size to 32 gallons (not to exceed 50 pounds), and Unincorporated Seminole County limits the size to 50 gallons (not to exceed 50 pounds). Waste Pro provides Winter Springs' residents with a heavy-duty, wheeled, 96-gallon garbage toter, which offers the City of Winter Springs a consistent community look as well as customer convenience/ease. It should also be noted that all three of the Unincorporated service areas have twice the number of households as Winter Springs.

Earlier this year, the University of Central Florida conducted an independent survey resulting in a score of 90.8%, which was sufficient for Waste Pro to receive a performance bonus. The survey results served as discussion points between Waste

Pro and the City and provide action steps for service improvement, including an educational initiative and expedited service issue resolution.

Given the results of both surveys (cost and customer satisfaction), staff recommends extending the term for one year, and Waste Pro is also willing to extend. The Solid Waste fund balance is sufficient to absorb the anticipated appropriation for operations.

RECOMMENDATION

Staff recommends the City Commission extend the term with Waste Pro for one year effective March 1, 2020.

**Solid Waste Cost Survey - October 2019
Seminole County Agencies**

Attachment A

Agency	Number of Households	Monthly Rate to Household	Service Provider	Rate Paid to Provider	Automated	Weekly Service Frequency (Garbage/Recycling/ Yard Waste)	"Exclusive" Franchise Type (Residential/Both Res & Commercial)	Contract Expiration
Altamonte Springs	6,792	\$21.75	City	n/a	No	2-G/1-R/1-Y	Residential	n/a
Casselberry	7,930	\$18.42	Waste Pro	\$14.04	No	2-G/1-R/1-Y	Residential	12/31/27
Lake Mary	5,438	\$19.69	Waste Pro	\$15.50	Semi	1-G/1-R/1-Y	Both	02/28/22
Longwood	5,057	\$19.11	Waste Pro	\$17.86	Semi	2-G/1-R/1-Y	Residential	09/30/21
Oviedo	12,233	\$19.76	Republic	\$17.77	Semi	1-G/1-R/1-Y	Residential	09/30/20
Sanford	14,479	\$19.20	Waste Pro	\$15.95	No	2-G/1-R/1-Y	Both	05/31/22
Unincorp SC (Area 1)	23,616	\$19.58	Waste Pro	\$14.40	No	2-G/1-R/1-Y	Residential	12/31/27
Unincorp SC (Area 2)	23,907	\$19.58	Waste Pro	\$15.19	No	2-G/1-R/1-Y	Residential	12/31/27
Unincorp SC (Area 3)	21,471	\$19.58	Advanced Disposal	\$13.14	No	2-G/1-R/1-Y	Residential	12/31/27
Winter Springs	11,792	\$18.10	Waste Pro	\$14.90	Semi	2-G/1-R/1-Y	Both	02/28/21



REGULAR AGENDA ITEM 502

CITY COMMISSION AGENDA | NOVEMBER 18, 2019 | REGULAR MEETING

TITLE

Reappointment/Appointment Opportunities to the Bicycle and Pedestrian Advisory Committee, Board of Trustees, Code Enforcement Board, and the Parks and Recreation Advisory Committee

SUMMARY

The City Clerk wishes to inform the City Commission of upcoming Appointments to the following:

Bicycle and Pedestrian Advisory Committee
Board of Trustees
Code Enforcement Board
Parks and Recreation Advisory Committee

The following is from the City of Winter Springs' Code of Ordinances, specifically,

ARTICLE III. - BOARDS, COMMITTEES, COMMISSIONS

DIVISION 1. - GENERALLY

Sec. 2-41. - Appointments of boards and committees.

(a)Purpose. The purpose of this section is to enhance the public's respect and confidence in the municipal services delegated to, and performed by, city boards and committees and to ensure that decisions of boards and committees are in the best interests of the city. The purpose of this section is also to establish uniform and consistent procedures and requirements for establishing and/or abolishing boards and committees, and appointing and removing members thereof, and for conducting board and committee business.

To the extent the provisions of this section conflict with other provisions of this Code, it is the intent of the city commission that the provisions of this section shall prevail.

(b)Definitions. As used in this section, the terms or phrases listed in this subsection shall have the following meaning:

"Resident" shall mean any person living within the city limits at all times while serving on said board or committee, and at least six (6) months prior to being nominated, elected or appointed to the board or committee.

(c) Requirements of board and committee members. Any person nominated, elected or appointed to serve on a board or committee of the city shall satisfy the following requirements, except as otherwise provided by state or federal law:

- (1) Complete a board or committee application as prescribed by the city commission;
- (2) Consent to a standard criminal background check;
- (3) Be duly registered to vote in Seminole County;
- (4) Be a resident as defined in this section; and
- (5) Has never been convicted or found guilty, regardless of adjudication, of a felony in any jurisdiction, any plea of nolo contendere shall be considered a conviction for purposes of this paragraph.

(d) Appointment of members. Unless otherwise required by state or federal law, or specifically provided otherwise in the Code, each city board and committee shall be comprised of at least five seats numbered one, two, three, four and five, and appointments shall be as follows:

- (1) Each city commissioner shall appoint one member to the seat on each city board or committee that corresponds to the city commissioner's seat. Appointments shall be made within thirty (30) days of the expiration of the prior term for that seat. If an appointment is not made within such thirty-day time period, the appointment shall be made by a majority vote of the commission. The city commission may accept appointments made by any commissioner or the mayor regardless of seat number.
- (2) For any seat not corresponding to a commission seat number, the city commission may accept appointments made by any commissioner or the mayor regardless of seat number.
- (3) All appointments to a city board or committee are not effective until the appointment is ratified by majority vote of the city commission.
- (4) A board or committee appointment shall not be construed as creating or conferring, upon a person, any right or interest in serving on a board or committee including, but not limited to a contract, liberty, property or vested right.

(e) Removal of members. Board and committee members shall serve at the pleasure of the city commission and may be summarily removed at any time with or without cause. If a member is removed, or vacates their appointment for any reason, including death, excessive absences, or resignation, prior to the expiration of their term, such vacancies in the board shall be filled by the city commission member whose seat number corresponds with the vacant board seat subject to commission ratification, for the unexpired term of such vacancy. If any commissioner fails to appoint a member within thirty (30) days after a vacancy

occurs or a term expires, that seat shall be filled by a majority vote of the commission.

(f)Term. Unless otherwise provided by state or federal law, all board and committee members shall be appointed to serve four-year terms and may be reappointed for subsequent four-year terms. All board and committee members shall be limited to three (3) consecutive full terms of office on any one board or committee.

BICYCLE AND PEDESTRIAN ADVISORY COMMITTEE

The Bicycle and Pedestrian Advisory Committee is a five (5) Member Committee, which meets quarterly, typically on the third Wednesday of March, June, September, and December.

The Term of Service for this Committee is four (4) years.

The following pertains to the Bicycle and Pedestrian Advisory Committee:

Sec. 2-43. - Bicycle and pedestrian advisory committee --Creation; composition; appointment of members.

(a)Pursuant to Transportation Element Policy 1.5.18 of the city's comprehensive plan, the city hereby establishes a trails advisory committee which shall be known as the "Bicycle and Pedestrian Advisory Committee."

(b)The committee shall have five (5) members and membership on the committee shall be in accordance with the terms of section 2-42 of this code except as expressly provided in this section. Effective April 27, 2015, the term of each committee member assigned by seat number shall be retroactively staggered to run concurrently with the same corresponding city commissioner seat, except that the committee member term shall expire on February 1 immediately following the expiration of the term of the corresponding city commissioner seat. Thereafter, all appointments shall remain staggered and shall be made for a term of four years. The committee may additionally include ex officio members, who may or may not be residents of the city, who can provide technical support or expertise in any aspect of the committee's work. Such ex officio members will have no voting power and cannot be used for the purpose of establishing a quorum for meetings. Any commissioner or the mayor may appoint an ex officio member but such appointment is not effective until ratified by majority vote of the city commission.

(c)Appointees to the committee shall have knowledge and experience or interest in the planning and implementation of a city interconnected trail and bicycle system network, as determined by application. No person shall be appointed with private or personal interests likely to conflict with the general public interest.

(d)The committee shall conduct four (4) quarterly regular meetings each year and may conduct additional special meetings as may be necessary to properly perform its duties and functions.

(e)The committee shall establish rules and or bylaws to govern the manner in which its meetings and affairs are conducted, provided that such rules and procedures are not inconsistent with federal and state law, the city code or direction of the city commission.

(f)The committee shall be subject to the Florida Public Records Act and the Sunshine Law.

Sec. 2-44. - Purpose and duties.

(a)The purpose of the committee is to promote trail, pedestrian and bicycle circulation systems and encourage increased use of non-motorized transportation in the city. The committee shall perform the following duties:

(1)Serve as an advocate for the adoption of a Trail and Bicycle System Master Plan for the city.

(2)Promote pedestrian and bicycle travel as a viable transportation choice to connect neighborhoods with parks, schools, commercial areas, and other destinations in the city and surrounding area.

(3)Assist with identifying funding sources and implementation strategies which further the development of an interconnected network of trails, sidewalks and bikeways within the city.

(4)Recommend to the city commission establishment, development, planning, funding and maintenance of specific trail, sidewalk and bicycle projects.

(5)Consider all matters submitted to it by the city commission or staff and shall offer suggestions or recommendations on its own initiative. It shall receive petitions and suggestions from the citizens of the city, and shall cooperate with civic groups, governmental agencies, and other organizations regarding trail, sidewalk and bicycle system planning and implementation.

*Bicycle and Pedestrian Advisory Committee
Appointment Opportunity:*

SEAT FIVE:

Seat Five - Commissioner Geoff Kendrick:
Vacant
Term Expires: February 1, 2021 [Partial Term]

BOARD OF TRUSTEES

The Board of Trustees is a five (5) Member Committee, which meets quarterly, typically on the second Thursday of February, May, August, and November.

The Term of Service for this Committee is four (4) years.

The following pertains to the Board of Trustees:

ARTICLE III. - PENSION PLAN

Sec. 14-52. - Board of trustees.

(a) There is hereby created and established a board of trustees consisting of five (5) members who shall be appointed and removed as set forth in section 2-41.

(b) The board of trustees shall meet no less than quarterly to review the performance of the pension plan and conduct such other business as the board deems appropriate and necessary.

(c) The board of trustees shall administer the city's pension plans pursuant to the provisions contained therein as adopted by the city commission.

(d) Staggering of terms. Beginning in January, 2012, seats two (2) and four (4) shall be appointed to four (4) year terms expiring in January 2016, and seats one (1), three (3) and five (5) shall be appointed to two (2) year terms expiring in January, 2014. Thereafter all appointments shall remain staggered and shall be made for a term of four years.

Board of Trustees

Reappointment/Appointment Opportunities:

SEAT TWO:

Seat Two - Deputy Mayor/Commissioner Kevin Cannon:
Seat currently held by Mr. David Withee
Term Expires: January 1, 2020 [Four (4) year Term]

SEAT FOUR:

Seat Four - Commissioner TiAnna Hale:

Seat currently held by Ms. Robin Paris

Term Expires: January 1, 2020 [Four (4) year Term]

CODE ENFORCEMENT BOARD

The Code Enforcement Board is a seven (7) Member Board, which meets monthly, on the fourth Tuesday, beginning at 5:30 p.m.

In accordance with Florida Statutes, the Term of Service for this Board is three (3) years.

The Code Enforcement Board has specific criteria related to its membership, as noted below:

Florida Statutes: 162.05 **Local government code enforcement boards; organization.**

(1)The local governing body may appoint one or more code enforcement boards and legal counsel for the enforcement boards. The local governing body of a county or a municipality that has a population of less than 5,000 persons may appoint five-member or seven-member code enforcement boards. The local governing body of a county or a municipality that has a population equal to or greater than 5,000 persons must appoint seven-member code enforcement boards. The local governing body may appoint up to two alternate members for each code enforcement board to serve on the board in the absence of board members.

(2)Members of the enforcement boards shall be residents of the municipality, in the case of municipal enforcement boards, or residents of the county, in the case of county enforcement boards. Appointments shall be made in accordance with applicable law and ordinances on the basis of experience or interest in the subject matter jurisdiction of the respective code enforcement board, in the sole discretion of the local governing body. The membership of each enforcement board shall, whenever possible, include an architect, a businessperson, an engineer, a general contractor, a subcontractor, and a realtor.

The following is an excerpt from the City's Code of Ordinances:

Sec. 2-58. - Code enforcement board and special magistrates.

(a) Code enforcement board.

(1) The code enforcement board shall consist of seven (7) members to be appointed by the city commission to seats numbered one (1), two (2), three (3), four (4), five (5), six (6) and seven (7) in accordance with section 2-41 of the City Code. Appointments to the board shall be on the basis of experience or interest related to the subject matter jurisdiction of the board. The membership of the code enforcement board shall be limited to residents of the city, and whenever possible, include an architect, a businessperson, an engineer, a general contractor, a subcontractor and a realtor or as otherwise provided by law.

(2) The members of the code enforcement board shall elect a chairman from among its members who shall be a voting member. The presence of four (4) or more members shall constitute a quorum of the enforcement board. Members shall serve without compensation, but may be reimbursed for such travel, mileage and per diem expenses as may be authorized by the city commission or otherwise as provided by law.

(3) The members of the code enforcement board shall serve in accordance with the City Code and may be suspended and removed for cause as provided in section 2-41 of the City Code. In addition, if any member fails to attend two of three successive meetings without cause and without prior approval of the chair, the code enforcement board shall declare the member's office vacant and refer the vacancy to the city commission who shall promptly fill the vacancy.

(4) Unless a code enforcement case has been assigned to a special magistrate in accordance with section 2-58(b)(5), or subject to a civil citation pursuant to subdivision B of this division 2, or otherwise being prosecuted by the city pursuant to some other lawful means, code enforcement officers shall notice code enforcement cases before the code enforcement board.

(5) Unless otherwise directed by the city commission, the city attorney's office shall serve as counsel to the code enforcement board.

(b) Special magistrates.

(1) The city commission may appoint one (1) or more special magistrates. Appointments shall be made in the sole discretion of the city commission in accordance with applicable law on the basis of experience or interest in the subject matter jurisdiction of the violations.

(2) Appointments shall be made for a term of one (1) year and may be renewed annually. Special magistrates may be reappointed at the discretion of the city commission. Special magistrates may be suspended and removed with or without

cause by the commission. Appointments to fill any vacancy shall be for the remainder of the unexpired term.

(3) Special magistrates shall be members of the Florida Bar in good standing for five (5) or more years. The special magistrate must demonstrate satisfactory knowledge of municipal law and the general procedures for enforcement of municipal codes, and must demonstrate a temperament suitable for the exercise of quasi-judicial powers vested in each special magistrate. Special magistrates shall not be city employees or officers. The city manager shall be responsible for negotiating and executing a contract on behalf of the city with the special magistrate and the special magistrate may be compensated at a rate to be agreed upon in the contract. The contract will be in a form prepared and approved by the city attorney.

(4) The city attorney may attend the code enforcement hearings conducted by the special magistrate and represent City staff in the presentation of cases, or the code enforcement officer may present cases, at the option of the city manager depending upon the substance and complexities of any given case. To the extent necessary and consistent with the city's interests to ensure compliance with City Codes, the city attorney will defend final orders of the special magistrate which are appealed by violators to a court of competent jurisdiction.

(5) Special magistrates shall handle code enforcement cases expressly required by the City Code, or cases noticed for hearing by a code enforcement officer, provided the city manager has authorized the code enforcement officer to notice a particular case before a special magistrate.

Type of employment of the current Code Enforcement Board Members:

- Michael Burns - Computer Technology/Analyst
- Matthew Criswell - Business Owner/Roofing Contractor
- Carole Giltz - Retired/Teacher
- Maurice Kaprow - Retired /School Administrator
- Dennis Robinson - Retired/Business
- Vacant
- Vacant

Code Enforcement Board

Appointment Opportunities:

SEAT TWO:

Seat Two - Commissioner/Deputy Mayor Kevin Cannon:

Vacant

Term Expires: July 2022 [Partial Term]

SEAT FIVE:

Seat Five - Commissioner Geoff Kendrick:

Vacant

Term Expires: July 2022 [Partial Term]

PARKS AND RECREATION ADVISORY COMMITTEE

The Parks and Recreation Advisory Committee is a nine (9) Member Committee, which meets quarterly, typically on the first Tuesday of February, May, August, and November.

The Term of Service for this Committee is four (4) years.

The following pertains to the Parks and Recreation Advisory Committee:

Sec. 2-45. - Parks and recreation advisory committee --Creation; composition; appointment of members.

(a) Pursuant to Recreation and Open Space Element Policy 1.1.2 of the city's comprehensive plan, the city hereby creates a Parks and Recreation Advisory Committee.

(b) The committee shall have nine (9) members and membership on the committee shall be in accordance with the terms of section 2-42 of this Code except as expressly provided in this section. Effective April 27, 2015, the term of each committee member assigned by seat number shall be retroactively staggered to run concurrently with the same corresponding city commissioner seat, except that the committee member term shall expire on February 1 immediately following the expiration of the term of the corresponding city commissioner seat. The four at-large committee members shall be retroactively staggered whereby the first two at-large committee members, currently serving on the committee on April 27, 2015 and identified by alphabetical order of their respective last names, shall have a term that expires on November 1, 2017 and the remaining two at-large committee members shall have a term that expires on November 1, 2019. Thereafter, all appointments shall remain staggered and shall be made for a term of four years. The membership of the committee shall, whenever possible, include the following:

- (1) An active member of the Winter Springs Senior Association;
- (2) An active member of a youth sports organization or program;
- (3) An individual who is active in planning or assisting with special events of the city;
- (4) An individual who is active in an adult sports organization or program;

- (5)An individual who uses or accompanies children in the use of city playgrounds;
- (6)An active member of a conservation group or agency, or an individual with experience in the use of parks for public purposes;
- (7)An individual who participates in or supervises children who participate in the city's summer program(s), civic center program(s), camp(s) or other similar program(s).
- (8)An individual who is active in fundraising efforts;
- (9)An individual with general interest in parks and recreation.

(c)Appointees to the committee shall have knowledge and experience or interest in the planning and implementation of city parks and recreational facilities, as determined by application. No person shall be appointed with private or personal interests likely to conflict with the general public interest.

(d)The committee shall conduct four (4) quarterly regular meetings each year and may conduct additional special meetings as may be necessary to properly perform its duties and functions.

(e)The committee shall establish rules and or bylaws to govern the manner in which its meetings and affairs are conducted, provided that such rules and procedures are not inconsistent with federal and state law, the city code or direction of the city commission.

(f)The parks and recreation advisory committee shall be subject to the Florida Public Records Act and the Sunshine Law.

Sec. 2-46. - Purpose and duties.

(a)The purpose of the parks and recreation advisory committee is to promote park and recreation programs of the city and to recommend to the parks and recreation director, as well as other city staff and the city commission as needed, policies and actions to promote, plan, design, construct and utilize city parks and related special events, fundraising and recreation programs. The committee shall perform the following duties:

- (1)Advise and assist the parks and recreation director, as well as other city staff and the city commission as needed, in matters involving or affecting city parks and recreation;
- (2)Keep the parks and recreation director, as well as other city staff and the city commission as needed, informed of the status and progress of recreational and parks services, plans, special events, fundraisers and activities;

(3) Advise and make recommendations to the parks and recreation director, as well as other city staff and the city commission as needed, regarding the promotion of citizen participation in recreation and park programs and distribution of information about leisure activities offered by the city; and

(4) Assist the parks and recreation director, as well as other city staff and the city commission as needed, in the implementation of the goals, objectives and policies of the Recreation and Open Space Element of the city's comprehensive plan.

*Parks and Recreation Advisory Committee
Reappointment/Appointment Opportunities:*

AT LARGE:

Seat currently held by Mr. Matthew Benton
Term Expired: November 1, 2019 [Four (4) year Term]
Mr. Benton would like to be Reappointed

AT LARGE:

Seat was held by Mr. Robert Osborne
Term Expired: November 1, 2019 [Four (4) year Term]
Mr. Osborne asked NOT to be Reappointed

RECOMMENDATION

Staff is recommending that Reappointments/Appointments be made, should that be will of the Mayor and City Commission:

BICYCLE AND PEDESTRIAN ADVISORY COMMITTEE:

SEAT FIVE:

Seat Five - Commissioner Geoff Kendrick:
Vacant
Term Expires: February 1, 2021 [Partial Term]

BOARD OF TRUSTEES:

SEAT TWO:

Seat Two - Deputy Mayor/Commissioner Kevin Cannon:
Seat currently held by Mr. David Withee
Term Expires: January 1, 2020 [Four (4) year Term]

SEAT FOUR:

Seat Four - Commissioner TiAnna Hale:
Seat currently held by Ms. Robin Paris
Term Expires: January 1, 2020 [Four (4) year Term]

CODE ENFORCEMENT BOARD:

SEAT TWO:

Seat Two - Commissioner/Deputy Mayor Kevin Cannon:
Vacant
Term Expires: July 2022 [Partial Term]

SEAT FIVE:

Seat Five - Commissioner Geoff Kendrick:
Vacant
Term Expires: July 2022 [Partial Term]

PARKS AND RECREATION ADVISORY COMMITTEE:

AT LARGE:

Seat held by Mr. Matthew Benton
Mr. Benton would like to be Reappointed
Term Expired: November 1, 2019 [Four (4) year Term]
New Term Expires: November 1, 2023 [Four (4) year Term]

AT LARGE:

Seat was held by Mr. Robert Osborne
Mr. Osborne asked NOT to be Reappointed
Term Expired: November 1, 2019 [Four (4) year Term]
New Term Expires: November 1, 2023 [Four (4) year Term]

OTHER MAYOR/COMMISSION APPOINTMENTS:

Included in this Agenda Item is the ability for the Mayor and/or any City Commission Member to make any other Appointment(s) that are deemed pertinent.

If any Appointment(s) are not made at this Meeting, subsequent Agenda Items can be brought forward on upcoming City Commission Meeting Agendas.