

Water & Sewer
Design & Construction Specifications



DEFINITIONS	3	
BASIC INFORMATION	4	
AUTHORITY		4
GENERAL		5
MATERIALS		8
WATER DISTRIBUTION SYSTEMS	9	
GENERAL		9
DESIGN STANDARDS		9
STANDARD REQUIREMENTS		10
TESTING		12
DISINFECTING		13
RECLAIMED WATER SYSTEM		14
SANITARY GRAVITY SEWERS	16	
GENERAL		16
DESIGN STANDARDS		16
TESTING		21
SANITARY SEWAGE FORCE MAINS	22	
GENERAL		22
DESIGN STANDARDS		22
STANDARD REQUIREMENTS		23
TESTING		25
SEWAGE PUMPING STATIONS	26	
GENERAL		26
DESIGN STANDARDS		26
TESTING		29
PIPE, PIPE FITTINGS, VALVES AND APPURTENANCES	29	
GENERAL		29
PIPE AND PIPE FITTINGS		29
VALVES		32
INSTALLATION		33
PIPELINE IDENTIFICATION		35
UTILITY EXCAVATION, TRENCHING AND BACKFILLING	36	
GENERAL		36
MATERIALS		36
WORKMANSHIP		36

CASING PIPE-BORING AND JACKING	40	
GENERAL		40
CASING PIPE MATERIALS AND INSTALLATION		41
APPENDIX	43	
Detail Drawings	52	
PIPE IDENTIFICATION AND WARNING TAPE		53
MINIMUM HORIZONTAL SEPERATION		54
FIRE HYDRANT		55
TEMPORARY BYPASS		56
BLOW OFF		57
TRACING WIRE CONNECTION		58
SINGLE POTABLE WATER SERVICE		59
POTABLE WATER SERVICE (WITH CASING)		60
RECLAIMED WATER SERVICE (WITH CASING)		61
DOUBLE SEWER LATERAL CONNECTION		62
SEWER LATERAL DETAIL		63
LIFT STATION DETAIL		64
LIFT STATION VALVE PIT		65
TYPICAL MANHOLE CONNECTION		66

SECTION 1

DEFINITIONS

A. DEFINITIONS

Except where specific definitions are used within a specific section, the following terms, phrases, words, and their derivation shall have meaning given herein when consistent with the context.

ANSI - means American National Standards Institute. Any reference to ANSI standards shall be taken to mean the most recently published revision unless otherwise specified.

ASTM - means American Society for Testing Materials. Any reference to ASTM standards shall be taken to mean the most recently published revision unless otherwise specified.

AWWA - means American Water Works Association. Any reference to AWWA Standards shall be taken to mean the most recently published revision unless otherwise specified.

CONTRACTOR - means the person, firm, or corporation with whom the Owner, the Developer or the CITY has made the contract for work.

DEVELOPER - means the person, firm, or corporation engaged in Developing or improving real estate for use or occupancy.

DEVELOPER'S ENGINEER - means an engineer or engineering firm registered with the State of Florida Department of Professional Regulation, retained by the DEVELOPER to provide professional engineering services for a project.

STANDARDS - means the minimum design standards contained in this MANUAL.

STANDARD DRAWINGS - means the detailed drawings in this MANUAL related to water and wastewater main materials and installation.

WATER MAINS - means water transmission mains, distribution mains, pipes, fittings, valves, hydrants, services, meters and miscellaneous related appurtenances.

WASTEWATER MAINS - means wastewater gravity sewers, force mains, pump stations, fittings, valves, service laterals, and miscellaneous related appurtenances.

WORK - means the labor, materials, equipment, supplies, services and other items necessary for the execution completion and fulfillment of the contract.

SECTION 2

BASIC INFORMATION

1. AUTHORITY

A. Approval

These design standards are accepted and approved by the City Utility Department.

B. Scope and Intent

It is intended for these development procedures to establish minimum engineering requirements for projects submitted to the Winter Springs Utility Department, hereafter referred to as the Utility. The development procedures will apply to all development and construction projects, both public and private, within the jurisdiction of the City of Winter Springs.

The specifications set forth herein are meant to provide minimum standards for the construction of potable and reclaimed water systems and sewage transmission and collection facilities that meet the following conditions:

- I Facilities to be constructed within the City of Winter Springs rights-of-way.
- ii Facilities to be turned over to the City of Winter Springs for operation.
- iii Facilities to become a permanent part of Winter Springs Utility Department.

These specifications are not meant to be totally restrictive in nature; that is, they do not depict the only acceptable method of design. Rather, their purpose is to describe minimum acceptable standards of construction and to promote uniformity where practical. It is felt that adherence to the standards presented in this booklet will benefit both the citizens of Winter Springs and the operations of the facilities.

Should any design be submitted which varies appreciably from the standards set herein or uses materials other than those recommended, it should be accompanied by appropriate supporting documentation or engineering studies.

Please note that all plans submitted for review must be in conformance with all Federal, State and City regulations and codes. In no case shall minimum standards be less than those established by recognized private and governmental agencies, unless stated otherwise in these specifications.

C. Variances, Waivers and Amendments

Under extreme conditions with specific applications the following Guidelines may be altered to meet certain conditions that are beyond the control of the developer and provided such deviations or alterations are acceptable by the City. The Utility Director or his designee shall make final decisions concerning variances and amendments and the City Commission as provided for in the adopting Resolution shall make amendments.

2. GENERAL

A. Pre-Design Conference

It is strongly recommended that pre-design conferences between the owner, his engineer and the Utility Director is held.

B. Plans

I Submission

- a.) All construction plans submitted to the Utility Director for review and approval shall bear the seal and signature of the Florida Registered Professional Engineer responsible for the project. The address and telephone number of this person shall be shown along with the signature.
- b.) Two sets of plans and specifications shall be submitted for approval to the Utility Department. One approved set shall be returned to the Engineer for the construction of the project.

ii Assembly

a.) Sheet Size

The standard size sheet for construction plans submitted to the City for approval shall be 24" X 36". Work sheets and data sheets used in preliminary design work and reviews are not limited to any size, except that which is convenient to handle.

b) Items of Construction Required

The developer shall provide as appropriate water and sanitary sewers, and all other necessary improvements in accordance with City specifications, standards and policies.

iii Utility Coordination

It shall be up to the developer to coordinate with all utilities concerning their development.

iv City Standards and Specifications

Copies of City standards and specifications may be obtained from the Land Development Coordinator or the Utility Department.

C. Construction

I Start

The Utility Inspector shall be notified in writing of the proposed date of the beginning of construction of the water and sanitary sewer facilities. Any time that work is to stop for a period of five (5) working days, the Utility Director shall be notified of such interruption.

ii Pre-Construction Conference

A pre-construction conference shall be held at least two (2) days before the commencement of construction. A construction schedule shall be furnished no later than the pre-construction conference. The developer shall be responsible for arranging this conference with the Engineering Department.

iii Completion

a.) As-Built Drawings

Within two weeks following inspection, the developer shall submit one set of as-built drawings to the Utility Director. These drawings shall be black or blue line prints signed by a registered engineer (the same one responsible for the originally approved design), attesting to the fact that the plans are, in fact correct. If facilities dedication to the City is desired, two sets of as-built drawings and one set of Mylar's shall be submitted two (2) weeks in advance of the desired date of acceptance by the Utility Department. A final as-built inspection is required for all projects.

b.) Certificates of Compliance

Certificates of compliance with the specifications furnished by the material supplier shall be submitted on all material used in the completion of this work upon request by the Utility Director's Office.

iv Off-Site Pollution Protection

It will be the developer's responsibility to provide siltation protection during construction. In the event such protection is inadequate, it will be the developer's

responsibility to remove any downstream salutation prior to the time of final inspection.

v Protection of potable water system

To protect the potable water system from contamination during the installation of new water mains, and to supply water for flushing and pressure testing. A temporary jumper connection with an approved REDUCED PRESSURE back flow device and WATER METER must be installed at all points where a connection to the potable water system is made.

vi Phased construction

Where construction is to be done in phases the water mains must terminate with a main line gate valve and blow off at the end of each phase. Sewer lines shall be extended from terminal manhole a minimum of twenty (20) feet from the pavement into the next phase.

D. Inspection

I Periodic

The Utility Inspector will periodically visit the project site to make a visual inspection of the progress of the work and methods of construction. Upon observation of work not done in accordance with the plans and specifications, the Utility Inspector will notify the developer's contractor and the developer or his designee and request that the necessary corrections be made or tests performed to assure compliance with the specifications, at no cost to the City.

ii Final

The Utility Director shall be notified in writing when the project is complete.

Upon receiving a verbal request for final inspection of the completed work, the Utility Inspector, together with the representatives of other interested agencies, shall perform the final inspection and by letter shall notify the developer's engineer of the results of the inspection within two weeks of the receipt of the request. In the case of facilities dedicated to the City, the final inspection will be conducted as final acceptance inspection after all necessary materials are submitted.

E. Bonds

All items or systems must be designed in such a manner as to minimize maintenance. A

performance bond of 110 percent of the estimated construction costs of the water and sewer facilities will be required when necessary. A two (2) year maintenance bond of 10 percent of the final construction costs shall be posted before the facilities can be accepted by the Utility.

F. Transfer of Private Ownership

When transfer of private facilities to public ownership takes place, all such private facilities shall be brought up to the current City standards at no cost to the City in so far as construction and maintenance are concerned before the City will accept such facilities. Proof of satisfactory completion of water and sewer facilities, satisfactory water bacteriological tests, approved FDEP certification of completion, maintenance bond, itemized construction cost, and the appropriate legal deeds shall be furnished to the Utility Director prior to acceptance.

G. Property Ownership

All facilities to be owned or maintained by the City shall be located on City property, within City rights-of-way or on easements dedicated to the City for the use intended.

H. Time Period of Approved Plans

Plans shall be valid for construction for a period of one year from the date of approval only. All items not under construction at this one-year date shall require a new approval prior to the commencement of construction.

3. MATERIALS

A. Trade Names

Wherever a product is called for by name - "or equal" shall be assumed to be included.

WATER DISTRIBUTION SYSTEMS

1. GENERAL

This section sets forth the general requirements for design and installation of water distribution systems for potable service.

2. DESIGN STANDARDS

A. Reference

Normal flow demands for design shall be calculated on the basis of full ultimate development as known, or projected. The average daily flow for domestic use shall be calculated at the minimum rate of 100 gallons per day per capita, with 3.5 persons per single family residence, and 2.5 persons per multi-family or mobile home dwelling unit. Maximum day demand to be used for design shall be 0.9 gallons per minute (GPM) per single-family residence and 0.7 GPM per dwelling unit for each multi-family or mobile home unit. Flow demands for commercial, industrial or other special developments shall be established from existing records or by estimated projections, using the best available data.

B. Water distribution systems and/or water main extensions shall be designed and constructed in accordance with the fire protection requirements of the Insurance Services Office (National Board of Fire Underwriters), as stated in their publication "Guide for the Determination of Required Fire Flows", if not in conflict with the following:

I Fire flows in single family residential areas shall provide 600 GPM at a 20 psi residual pressure.

ii Fire flows in commercial, institutional, industrial areas and apartment or multi-unit complexes shall provide 1,250 GPM at a 20 psi residual pressure.

iii Fire Hydrants

Distance from or spacing for hydrants located within residential subdivisions shall not exceed 750 feet (measured along the main) and shall be connected to water mains of 6 inches minimum size, which are of satisfactory loop design. Minimum distance and size requirements for all other district areas are 500 feet and 8 inches, respectively (measured along the main).

iv System Size Computation

The minimum design for water distribution systems shall provide for at least 100% of the combined maximum day-demand rate and required fire flow for said rate, with special

provisions for peak flows in excess thereof. The allowable minimum service pressure under said design condition shall not be less than 20 pounds per square inch. Design computation shall be by the "Hardy-Cross" procedure, or other applicable methods, as dictated by the system configuration. Design flows and method of computation shall be subject to review and approval by the Utility.

v Valve Locations

Valves shall be provided for all branch connections, loop ends, fire hydrant stubs, or other locations, as required to provide operable, easily maintained, and repaired water distribution system. Valves are to be placed so that the maximum allowable length of water main required to be shut down for repair work shall be 500 feet in commercial, industrial or multi-family residential areas, or 1,000 feet in other areas.

vi Reflective Location Marker

A blue sided reflective pavement marker shall be installed in the center of the traffic lane that is nearest the fire hydrant. The marker shall be directly in-line with the 4-1/2" steamer port on the front of the hydrant. The pavement marker shall be installed with a suitable epoxy type adhesive as recommended by the marker manufacturer.

3. STANDARD REQUIREMENTS

A. General

The materials of construction and general installation procedures, with the exception of fire hydrants, shall comply with the specific applicable standards set forth under Section 8, "Utility Excavation, Trenching and Backfilling", Section 7 "Pipe Fittings, Valves and Appurtenances", as well as "Standard Details-Water Distribution Systems".

B. Fire Hydrants

Hydrants shall comply with AWWA Standard C502, "Fire Hydrants for Ordinary Water Works Service", and shall be equipped with a minimum of one (1) pumper outlet nozzle 4-1/2 inches in diameter and two (2) hose nozzles 2-1/2 inches in diameter. Acceptable hydrants are Mueller, Clow or American Darling. Outlet nozzles shall be on the same plane, with minimum distance of 18 inches from center of nozzles to ground line. Valve shall be compression type with 5-1/4 inches minimum opening and show inlet connection to be 6 inches minimum.

I Hydrants shall be installed plumb and in true alignment with the connection pipes to the water main. They shall be secured to the hydrant valve with MJ anchoring coupling or approved restraint assemblies. All hydrants shall be installed with drain holes plugged. Installed hydrants shall be painted Sherwin Williams safety yellow prior to acceptance of the distribution system.

ii Hydrant placement shall not be at a distance greater than 18 feet from a paved stabilized area

which can withstand the weight of a Class A pumper. The center of the steamer port shall be 18 inches above final grade. Steamer port shall be correctly positioned for the proper connections.

- iii Hydrant valve shall be connected to the water main with MJ tee and the hydrant shall be connected to the valve with a MJ anchoring coupling or approved restraint assemblies may be substituted with the approval of the Utility Director.

C. Joint Restraining

Pressure piping, fittings and other items requiring restraint, shall be restrained with Mega-Lug or other approved restraining assemblies. Said restraining devices shall be designed for the maximum pressure condition (testing) and the safe bearing loads for horizontal thrust.

D. Pipe Depth and Protection

The standard minimum cover for water distribution systems shall be 36 inches from the top of the pipe to finish grade. However, should this design not be feasible, protective concrete slabs shall be provided over the pipe within the limits of the lesser cover. Where waterways, canals, ditches or other cuts are crossed, protective concrete slabs and ductile iron pipe shall also be installed across and to 10 feet each side of the bottom. Additionally, approved utility crossing signs shall be placed on the pipe alignment at each side of the canal, etc.

E. Connections at Structures

Where pipes are to extend into or through structures, DI pipe and flexible joints are to be provided at the wall face.

F. Special Exterior Protection for Corrosion

Steel pipe shall not be installed in severe corrosion areas.

G. Air Venting and Blow-Offs

Where the water main profile is such that air pockets or entrapment could occur, resulting in the blockage, methods for air release shall be provided. Air venting capabilities shall be provided for distribution mains by appropriately placing fire hydrants, blow-offs, or other manual devices. At critical points on major mains, automatic air release assemblies shall be installed. Special care shall be taken to preclude any cross-connection possibility in the design of automatic air release valve application. All dead-end water mains, temporary or permanent, shall be equipped with a manually operated blow-off at the terminal.

H. Service Connections

Taps for all service connections on existing mains shall be made under pressure. All brass fittings must be lead free. Connections to water mains shall be

made by installing the appropriate tapping saddle and corporation stop and drilling the appropriate size hole. Water service lines from the main to the curb stop shall have a minimum diameter of one (1) inch, and shall not be placed closer than two (2) feet from the bell of the pipe. Service lines installed under roads or other paved areas shall be incased in a PVC pipe of adequate size to push the service line through it. (2" minimum for 1" service lines). All curb stops must be of the Ford type with meter coupling licking flange and shall be one piece brass construction ball-valves with locking provisions. For one (1) inch double service connection, straight "U" branch & curb stop assemblies with 7-1/2 inch spacing shall be required. On curbed streets the exact location for each installed service shall be marked in the concrete curb and painted blue. Maximum letter dimensions shall be a height of 6 inches, a width of 3 inches, and a depth of 1/8 inch. Where no curb exists or is planned, locations shall be adequately marked by a method approved by the Utility Inspector.

4. TESTING

- A. The contractor shall perform hydrostatic testing of all water distribution systems, as set forth in the following, and shall conduct said tests in the presence of representatives from the City's Utility Department and the design Engineer, with 48 hours advance notice provided.
- B. Piping and appurtenances to be tested shall be within sections between valves, unless alternate methods have received prior approval from the Utility Inspector. Testing shall not proceed until all restraining devices have been installed. All piping shall be thoroughly flushed prior to testing to clear the lines of all foreign matter. While the piping is being filled with water, care shall be exercised to permit the escape of air from extremities or the test section, with additional release cocks provided if required.
- C. Hydrostatic testing shall be performed at 150 pounds per square inch pressure, unless otherwise approved by the Utility Director, for a period of not less than two (2) hours. Testing shall be in accordance with the applicable provisions as set forth in AWWA Standard C605-94, Section 7. The allowable rate of leakage shall be less than the number of gallons per hour determined by the following formula:

$$\frac{L = ND (P)^{1/2}}{3700}$$

L = allowable leakage in gallons per hour
 N = number of joints in section tested
 D = nominal diameter of the pipe in inches
 P = average test pressure maintained during the leakage test in pounds per square inch gauge

OR

$$Q = (D1 \times S1) + (D2 \times S2) + (D3 \times S3) \times P \times H / 133,200$$

Where, D= Diameter of line tested (inches)
 S = Length of line tested (feet)
 P = Square root of average test pressure
 Q = Allowable leakage (gallons)
 H = Test duration (hours)

- D. The testing procedures shall include the continued application of the specified pressure to the test system, for the two hour period, by way of a pipe taking supply from a container suitable for measuring water loss. The amount of loss shall be determined by measuring the volume displaced from said container.
- E. Should the test fail, necessary repairs shall be accomplished by the contractor and the test repeated until within the established limits. The contractor shall furnish the necessary labor, water, pumps, gauges and all other items required to conduct the required water distribution system testing and perform necessary repairs.

5. DISINFECTING

- A. Following the pressure testing: the contractor shall disinfect all sections of the water distribution system, and receive approval thereof from the appropriate agencies, prior to placing in service. 24 hour advance notice shall be provided to the Utility Inspector before disinfection and shall be accomplished with the applicable provisions of AWWA Standard C651-92, "Disinfecting Water Mains," and all appropriate agency approvals.
 - I Care shall be taken to provide disinfection to the total system and extremities shall be carefully flushed to accomplish this end. After disinfection has been accomplished, samples of water for bacteriological analysis shall be collected and submitted to a certified laboratory for bacteriological testing. Should these samples or subsequent samples prove to be unsatisfactory, then the piping shall be disinfected until satisfactory samples are obtained.
 - ii The contractor shall furnish all equipment and materials and perform the work necessary for the disinfecting procedures, including additional disinfection as required.
 - iii Copies of the bacteriological results shall be given to the Utility Inspector before the City will accept any water mains.

6. RECLAIMED WATER SYSTEM

A. Construction Standards

- I PVC pipe used in the construction of the reclaimed water system shall be C900 DR-18. Ductile iron pipe shall be Class 300 minimum. Installation shall be performed in accordance with applicable provisions of AWWA Standard C600 (ductile iron) and AWWA Manual M23 (PVC Pipe).
- ii PVC pipe used for reclaimed lines shall be color coded by use of an acceptable purple pigment. The pigmentation shall impart no qualities to the pipe other than color and the pipe shall be NSF approved.
- iii Improperly color-coded pipe will not be accepted. Tape for pipe 4" and below shall be 3" wide purple with 1" high yellow or white letters reading "CAUTION RECLAIMED WATER MAIN". There shall be one-foot separation between identifiers. Tape for 6" through 12" mains shall be 6" wide with all the same specification as above.
- iv Non Metallic ribbon shall be installed on top of all potable and reclaimed lines. Ribbon is to be laid 18" above all potable and reclaimed lines. Pipeline identification locator wire is to be installed on top of all sewer force mains. Locator wire shall be a single strand 14 gauge plastic coated electric wire, laid on top of, and secured with duct tape every five feet continuously over the entire length of the main. Valve boxes are to be used as junction points to access the wires. Locator wires are to be secured to the main with duct tape approximately every five feet.
- v All service line piping, valves and service boxes shall be properly color coded and or marked to differentiate the reclaimed water from potable water.
- vi A maximum separation of reclaimed water mains and potable water mains shall be maintained. A minimum horizontal separation of five (5) feet center to center, but not less than three (3) feet between outside edges of pipe shall be maintained. Where reclaimed water mains and potable water mains cross with less than eighteen (18) inches vertical clearance, the reclaimed water main shall be twenty (20) feet of ductile iron pipe centered at the point of crossing.
- vii Standard AWWA C901-88 PE 3408 (purple) polyethylene tubing shall be used on all reclaimed water service lines up to two (2) inches in diameter. Single service residential service lines shall be one (1) inch diameter and double service lines shall be one and a half inch with a 1 1/2"X 1"X 1" Wye branch (Ford No. Y44-264) or equivalent. Service lines installed under roads or other paved areas shall be incased in a PVC pipe of adequate size to push service line through it. (2" minimum for 1" service lines).
- viii Valves for underground service shall be resilient seated gate valves conforming to AWWA C509 non-rising stem type, and shall be equipped with 2-inch square cast iron wrench nuts.

- ix One (1) to two (2) inch valves installed on the reclaimed water mains shall be corporation stops with pack joint couplings conforming to AWWA C800. As manufactured by Ford Meter Box Company (Ford type F1100 or FB1100).
- x Curb stops for 1" service lines shall be ball valve type conforming to AWWA C 800-84 as manufactured by Ford Meter Box Company with "Reclaimed Water" stamped on the top of the tee head. Ford part number BRW41-344W.

B. SPECIAL ITEMS

I Tapping Saddles

Tapping saddles shall be fabricated of ductile iron and suitable for either wet or dry installation and shall be as manufactured by American Cast Iron Pipe Company or approved equal. The sealing gasket shall be "O-Ring" type suitable for the applicable service. Outlet flange shall be ANSI B16.1, 125 lb. standard. The straps and bolts shall be a corrosion resistant alloy steel.

ii Service Saddles

Saddles for cast or ductile iron pipe shall be double strap, ductile iron, type 313 for plastic pipe, types 242 or 352, as applicable. Sealing gaskets shall be suitable for the applicable service and straps shall be corrosion resistant alloy steel. Service tapping saddles for one (1) inch through two (2) inch taps shall be Ford style F202 double strap or style FC101 or equivalent.

iii Valve Boxes

Reclaimed water valve boxes shall be adjustable, cast iron, minimum interior diameter of 5 inches, with 6" X 6" square covers, cast with the applicable inscription in legible lettering on the top "RECLAIMED WATER". Valve boxes shall be suitable for the applicable surface loading and valve size. Valve boxes not in the pavement shall have around their tops reinforced concrete pads, which will be flush with the finished grade at valve site (top of the curb or above if necessary) with minimum dimensions of 18"X 18"X 3".

iv Service lines installation

Service lines installed under roads or other paved areas shall be incased in a PVC pipe of adequate size to push service line through it. (2" minimum for 1" service lines). Filter fabric shall be installed over both ends of the PVC pipe.

SECTION 4

SANITARY GRAVITY SEWERS

1. GENERAL

This section includes general technical criteria for the design and installation of sanitary sewer systems.

2. DESIGN STANDARDS

A. General

The Developer shall comply with the applicable requirements specified within WPCF Manual of Practice No. 9, and Chapter 20 of the Ten-State Standards-Recommended Standards for Wastewater Facilities and as established by the Florida Department of Environmental Protection.

B. System Design

I Average Daily Flow (ADF)

The sewer system design shall be based on full ultimate development as known, or projected. The average daily flow (ADF) from domestic units shall be calculated at the minimum rate of 100 gallons per capita per day, which will normally cover infiltration, but should conditions be unfavorable, an additional allowance shall be included. Single-family residences shall be computed at the rate of 3.5 persons per connection and multi-family or mobile home dwellings at 2.5 persons per unit. Flow requirements from commercial, industrial, institutional, or other special development areas shall be established from existing records or by estimated records or by estimated projections using the best available data; however, in no case shall a rate of less than 2,000 gallons per acre per day be used, unless specifically approved otherwise.

ii Maximum Daily Flow

Gravity sewers shall be designed on the basis of ultimate development maximum rates of flow. The maximum flow shall be 2.0 times the cumulative ADF.

iii Sewer Size Computation

Sanitary sewers shall be sized to provide ample capacity for the maximum flow rates. The minimum allowable size for any sewer, other than service connections, shall be 8 inches in diameter. All sewers shall be designed at slopes providing a minimum velocity of not less than 2 feet per second when flowing full or half-full. Said computation shall be based on Manning's Formula, using a roughness coefficient ("n") of not less than 0.013, unless justifiable approved otherwise. Polyvinyl Chloride pipe may use roughness coefficient of not

less than 0.009. Polyvinyl chloride pipe of 8-inch diameter may use a minimum slope of 0.40 feet per 100 feet. Prior approval of slopes for polyvinyl pipe of larger diameters shall be attained from the Utility Department before final construction plans are submitted. In general, the following minimum slopes shall be provided for sewer sizes to 24 inches:

MINIMUM SLOPE	
<u>SEWER SIZE</u>	<u>(Feet per 100 feet)</u>
8 inches	0.40
10 inches	0.28
12 inches	0.22
14 inches	0.17
15 inches	0.15
16 inches	0.14
18 inches	0.12
20 inches	0.11
21 inches	0.10
24 inches	0.08

Minimum slopes slightly less than those indicated may be considered in extreme situations; providing the depth of flow will not be less than 0.3 of the pipe diameter or the velocity less than 1.6 feet per second at design average daily flow, and justifiable reasons for the modification are presented to the Utility Director.

iv Design Considerations

- a.) Sewer 24 inches in diameter or less shall be installed with straight alignment and grade between manholes, with manhole spacing not to exceed 400 feet for sewers; Straight alignment shall be checked by either using a laser beam or lamping.
- b.) Curvilinear alignment of sewers larger than 24 inches may be considered on a case by case basis providing compression joints are specified and ASTM or specific pipe manufacturers’ maximum allowable pipe joint deflection limits are not exceeded. Curvilinear sewers shall be limited to simple curves, which start and end at manholes. When curvilinear sewers are proposed, minimum slopes must be increased accordingly to provide a recommended minimum velocity of 2.0 feet per second when flowing full.
- c.) All sanitary sewers shall terminate at manholes except under special conditions, such as short runs into cul-de-sacs, etc., where clean outs may be considered.
- d.) Services laterals and fittings shall be a minimum of 6 inches in diameter. All service laterals shall be less than 100 feet in length.
- e.) In general, service laterals shall not be allowed to discharge into sanitary manholes, except at terminal manholes.

- f.) Maximum depth allowed for any sewer pipe shall not exceed 12 feet.
- g.) Finished floor elevation must be a minimum of 12" above the nearest downstream manhole rim elevation.

C. Manholes

- I Manholes shall be installed at the end of each gravity sewer; at all changes in grade, size or alignment; at all sewer intersections; and at distances not greater than 400 feet. Private sewer systems must be separated from the CITY sewer system by a manhole located at the right-of-way line.
- ii Manholes shall be pre-cast concrete. The minimum inside diameter of manholes shall be 48 inches for sewer sizes to 21 inches in diameter or less, with submittal of special designs for larger pipes. No interior ladders shall be permitted in manholes. Minimum wall thickness shall be 5 inches.
- iii Pre-cast reinforced manholes shall be in accordance with ASTM Designation C478, with pre-formed flexible plastic joint sealer conforming to Federal Specification SS-S-0210 (GSA-FSS), "Ram-Nek", as manufactured by the K.T. Snyder Co., Inc. Houston, Texas or approved equal.
- iii Manhole frames and covers shall be gray cast iron conforming to ASTM Designation A48, Class 30, and shall have a minimum 24-inch opening. Covers shall have no perforations and shall be marked with the words "Sanitary Sewer". Frames and covers shall be fully bedded in mortar to the correct finish grade elevation, with adjustment brick courses placed between the cone and frame. Bricks shall be a maximum of four (4) courses.
- iv Manhole flow channels shall have smooth and carefully shaped bottoms, built up sides and benching constructed from concrete. Channels shall conform to the dimensions of the adjacent pipe and provide changes in size, grade and alignment evenly. Flow direction changes in excess of 90 degrees shall not be allowed. When directional changes exceeding 45 degrees occur, an additional flow line elevation drop of 0.1 foot across the manhole shall be provided.
- v Sewer clean outs located in paved or concrete areas must utilize recessed brass caps, cleanouts located outside paved or concrete areas must utilize recessed PVC caps. Cleanouts will be installed flush with finished grade.
- vi An outside drop pipe shall be provided for a sewer entering a manhole where its invert elevation is 18 inches or more above the manhole invert. Where the difference in elevation

between the incoming sewer invert and manhole invert is less than 18 inches, the manhole invert shall be filleted to prevent solids deposition.

D. Grease Traps

Where a grease trap is required, all kitchen wastewater and building floor drain wastewater shall first pass through the grease trap prior to being discharged into the CITY sewer system. Grease traps must be located so as to provide easy access for routine inspection, cleaning and maintenance. Manhole covers shall be provided over the inlet and outlet of each interceptor and be brought to finished grade.

Sizing the grease trap shall be based on the following table. The minimum and maximum volumes of any grease trap shall be 750 gallons 1250 gallons, respectfully. If the volume is greater than 1250 gallons, than installation of grease traps in series is required.

Fast Food Restaurants	10 gallons per seat	(single)
	5 gallons per seat	(in series)
General Service Restaurants	20 gallons per seat	(single)
	10 gallons per seat	(in series)
24-Hour Restaurants	30 gallons per seat	(single)
	15 gallons per seat	(in series)
Manufacturing Cafeterias	3 gallons per meal	(single)
	1.5 gallons per meal	(in series)

E. Pipe Depth and Protection

The standard minimum cover for sewer systems shall be 36 inches from the top of the pipe to the finished grade. Where this condition cannot be met, special consideration will be given.

Special care shall be exercised in the design and installation to provide adequate bedding for the type of pipe used, taking into consideration trench width and depth, superimposed loadings above grade and the material below trench grade. Pipe loading capabilities shall be computed in accordance with established design criteria and special supporting bedding or facilities shall be provided as required.

F. Pipe Bedding

Special care shall be exercised in the design and installation to provide adequate bedding for the type of pipe used, taking into consideration trench width and depth, superimposed loading above grade and the material below trench grade. Pipe loading capabilities shall be computed in accordance with established criteria and special supporting bedding or facilities shall be provided as required.

G. Connections at Structures

Where sanitary sewers connect to manholes or other structures, the pipe bell shall not be installed at the wall face. Kor-N-Seal Flexible Manhole Sleeves as manufactured by N.P.C. Systems, Inc, cast in the manholes and sized for the incoming and outgoing pipe shall be used. Connections shall be finished with the application of cement grout filling to the contour of the manhole.

H. Transition Connections

Where pipes of alternate materials are to be connected between manholes, suitable approved hard transition couplings shall be installed.

I. Pipe Cutting

The cutting of pipe shall be performed by the proper tools and methods.

J. Service Connections

Installation shall be performed by proper construction methods. Construction shall include the installation of wye branches on the sewer main and at the point of connection of the service pipe. The required piping and fittings shall extend to the property line and terminate a maximum of 5 feet below ground level, with stopper ends or fittings. The minimum service pipe size shall be 6 inches in diameter and may provide for single (4 X 6 inch) wye or double connections (4 X 4 X 6 inch) double wye. The clean out of the 6-inch wye shall be brought to 3 feet above the ground surface to facilitate TV inspections, after which they shall be cut off and capped at ground level. On curbed streets, the exact location for each installed service shall be marked by etching or cutting an "S" in the concrete curb and painted green. Maximum letter dimensions shall be a height of 6 inches, a width of 3 inches, and a depth of 1/8 inch. Where no curb exists or is planned, locations shall be adequately marked by a method approved by the Utility Inspector.

K. Protection of Water Systems

The horizontal separation between sanitary sewers and existing or proposed water mains shall not be less than 10 feet. Special consideration will be given where this is not possible. The vertical separation between sewer pipes and existing or proposed water mains shall not be less than 18 inches. Special consideration will be given where this is not possible. Contact the Utility Department for special requirements.

3. TESTING

- A. The Contractor shall perform testing of all sanitary gravity sewers, as set forth in the following and shall conduct said tests in the presence of representatives from the Utility Director's office and/or other authorized agencies with 48 hours advanced notice provided.
- B. The installed sewers mains and service laterals shall be TV inspected in order to ascertain that the joints are tight and the lines are clear and to correct alignment.
- C. Sanitary sewers to be inspected shall be within manhole sections. Inspections shall not proceed until all facilities are in place and concrete cured. All piping shall be thoroughly cleaned prior to testing to clear the lines of all foreign matter.
- D. Infiltration shall not exceed 200 gallons per day per inch of diameter per mile as measured between manholes. Testing shall proceed for a continuous period of two (2) hours, with infiltration amounts measured by methods approved by the Utility Dept.
- E. Ex-filtration tests shall be performed where pipelines are laid above ground water table.
- F. Should any test fail, necessary repairs shall be accomplished by the Contractor, and the test repeated until the established limits are met, and shall be at no cost to the City.

SECTION 5

SANITARY SEWAGE FORCE MAINS

1. GENERAL

- A. This section includes the general requirements for design and installation of force main systems serving sanitary sewage pumping stations.
- B. The relevant provisions of other sections of this specification shall be applicable to this section unless otherwise indicated herein or approved by the Utility Director.

2. DESIGN STANDARDS

A. Reference

The Developer shall comply with the applicable criteria set forth in WPCF Manual of Practice No. 9, and the Department of Environmental Protection requirements. Additionally, ASCE publication Pipeline Design for Water and Wastewater may be used as a design guide, if not in conflict with other requirements.

B. System Design

Force Main systems shall be of adequate size to efficiently transmit the total ultimate peak operational flows, applied by the connected sewage pumping stations(s) to the effluent point. Consideration shall be given to possible future connecting pumping system(s), along with future flow requirements, if applicable. In order to provide adequate pipeline cleansing, force main flow velocity shall not be less than 2 feet per second at ultimate design minimum pumping capacity; or exceed 10 feet per second as a maximum, however, with multiple pumping station systems or phase development, this requirement may not be possible and the system design shall receive special attention regarding cleaning maintenance.

C. Operational Cost Considerations

In addition to initial capital expenditure, long term pumping station operational costs shall also receive consideration when sizing force main systems.

3. STANDARD REQUIREMENTS

A. General

The materials of construction and general installation procedures shall comply with specific applicable standards set forth under Section 8, "Utility Excavation, Trenching and Backfilling", Section 9, "Casing Pipe-Boring and Jacking", and Section 7, "Pipe Fittings, Valves and Appurtenances".

B. Joint Restraining

Pressure piping fittings and other items requiring restraint shall be restrained using a Mega-Lug, or equivalent restraining assemblies as required by design. Restraining devices shall be designed for the maximum pressure condition (testing) and the safe bearing loads for the horizontal thrust.

C. Pipe Depth and Protection

The standard minimum cover for sewage force main systems shall be 36 inches from the top of the pipe to finish grade. Where this condition cannot be met, special consideration will be given.

D. Air and Vacuum Venting

Where the force main profile is such that air pockets or entrapment could occur resulting in flow blockage, provisions for air release shall be provided. Where free flow will occur during operation or after pumping stops, combined air release and vacuum valve assemblies shall be provided.

E. Valve Locations

Ball valves suitable for sewage shall be installed on all subsidiary force mains at the point of connection to the major main and where force mains are to be extended. At future connection branches or ends, the valves shall be restrained by methods other than thrust blocking in order to facilitate said connection without system shut down.

F. Branch Connections

Tee fitting connections are acceptable provided the connection is adequately blocked or otherwise restrained.

G. Clean Out Connections

Should force mains appear to be susceptible to sedimentation clogging, as created by depressed crossings or extended low flow (velocity) periods, suitable clean out connections shall be provided.

H. Terminal Discharge

Force mains shall enter the terminal facility (gravity sewer manhole, pumping station wet well, or other) at a point equal to the operational water level of said receiving unit. Should an elevation drop be required to obtain the outlet connection, the prior down-slope of the force main shall not exceed 45 degrees and adequate air venting shall be provided at the profile breakpoint.

I. Identification

In order to preclude possible domestic water tapping, all installed underground sanitary sewage force mains shall be identified per Section 7-5A.

4. TESTING

- A. The Contractor shall perform hydrostatic testing of all sanitary sewage force mains, as set forth in the following, and shall conduct said tests in the presence of representatives from the Utility Inspector's office and/or authorized agencies with 48 hours advance notice provided.
- B. Piping and appurtenances to be tested shall be within sections between valves or adequate plugs, with prior approval from the Utility Inspector's office. Testing shall not proceed until restraining devices are installed. All piping shall be thoroughly cleaned and flushed prior to testing to clear the lines of all foreign matter. While the piping is being filled with water, care shall be exercised to permit the escape of air from extremities of the test section, with additional release blocks provided if required.
- C. Hydrostatic testing shall be performed at 100 psi for all sizes of force mains. The testing procedures shall continue for an uninterrupted period of not less than two (2) hours. Testing shall be in accordance with the applicable provisions as set forth in Section 13 of AWWA Standard C600. The allowable rate of leakage shall be less than the number of gallons per hour determined by the following formula:

$$\frac{L = ND (P)^{1/2}}{3700}$$

L = allowable leakage in gallons per hour

N = number of joints in section tested

D = nominal diameter of the pipe in inches

P = average test pressure maintained during the leakage test in pounds per square inch gauge

- D. The testing procedures shall include the continued application of the specified pressure to the test system, for the two hour period, by way of pump taking supply from the container suitable for measuring the volume displaced from said container.

Should the test fail, necessary repairs shall be performed by the contractor and the test repeated until the test falls within the established limits. The contractor shall furnish the necessary labor, water, pumps, gauges, and all other items required to conduct the required sanitary sewage force main testing and shall perform the necessary system repairs required to comply with the specified hydrostatic test.

SECTION 6

SEWAGE PUMPING STATIONS

1. GENERAL

- A. This section includes the general requirements for the design criteria and installation of sewage pumping stations.
- B. The relevant provisions included in these specifications shall be applicable to this section, unless otherwise indicated herein or approved by the Utility Director.

2. DESIGN STANDARDS

A. References

The Developer shall comply with the applicable regulations established by the Florida Department of Environmental Protection. Additionally, the criteria provided in Chapter 30, "Sewage Pumping Stations", of the "Ten-State Standards--Recommended Standards for Sewage Works", and WPCF Manual of Practice No. 9 may generally be utilized as design guidelines, if not in conflict with state, county or other regulatory agency requirements.

B. Design Flows

Sewage pumping stations shall be designed for the total ultimate development flow from all contributory areas. The design average daily flow shall be computed at the unit rates set forth under Section 4. The maximum required pumping capability shall be the product of selected peak factors times the accumulative average daily flow (ADF) from the total service area. In general, the following factors shall be applicable for the range of flow, contributions indicated (million gallons per day-average daily flow): MGD-ADF, unless larger values are required or smaller amounts are justified, with prior approval from the Utility.

<u>Flow Range</u>	<u>Peak Factor</u>
-- to 0.05 MGD-ADF	3.5
0.05 to 0.25 MGD-ADF	3.0
0.25 to 2.00 MGD-ADF	2.5

C. Pump Selection

- I For pumping stations with a peak design flow demand of 1,500 gallons per minute (GPM) or less, a minimum of two pump units shall be provided. Where the peak design flow exceeds 1,500 GPM, three or more units shall be included in the facility.

- ii The selected sewage pump system shall have the minimum capability of pumping the design peak flow at the maximum computed system total dynamic head (TDH) requirements.
- iii Head-Capacity curves shall be prepared for the proposed pumping system in order to determine the various operational conditions. Hydraulic computations shall be in accordance with good engineering practice, with pipe friction loss calculated by the "Hazen-Williams Formula", using standard friction factors based on the materials utilized.

D. Wet Well Design

The wet well structure shall provide a minimum capacity between operational water levels sufficient to allow a minimum of five (5) minutes between successive starts of the pumps, when the influent rate is one-half the maximum one pump capacity. Low water levels shall provide adequate submergence to preclude pump inlet vortexing, air binding or other design considerations. Operational maximum high water levels shall not exceed the invert elevation point of said pipe. A minimum size hopper bottom shall be provided, with the wet well floor sloping to said bottom at a slope of not less than one to one (1:1). Additionally, where the wet well extends below the ground water table, the structure shall be designed to eliminate any possibility of flotation. No interior ladders shall be permitted in the wet well. Design large enough to handle a minimum of four hours down time.

E. Station Water System (Non-Potable)

All sewage pumping stations shall be provided with a station water system, with adequate capacity and pressure, for wash-down or other requirements. Said supply shall be completely separated from the potable supply by use of reduced pressure zone vacuum breaker or other approved protective systems.

F. Emergency Pump Connections

For sewage pumping stations, connections shall be provided for emergency bypass pumping and generator capability. Lift stations will be equipped with a Pyle National JRE 4100 emergency power connection. By-pass pumping capabilities shall also be provided.

G. Sewage Pumps and Motors

I Sewage pumping units shall be capable of handling raw, unscreened sewage and shall be capable of passing a sphere of at least 3 inches in diameter. Pumps shall be electric motor driven and of proven design that has been in sewage service under similar conditions for at least five years. Pumps shall provide the required peak design performance requirements and be suitable for operation within the total hydraulic range of operation. Electrical service to the lift station shall be three-phase service.

ii Pump Motors

Electrical pump motors should be three-phase non-overloading, excluding service factor, throughout the entire operating range of the pumps.

iii Pump Controls

Each pumping station control system shall include a liquid level controller which shall sense the sewage level in the wet well and provide appropriate signals to the logic circuits to produce the required mode of operation for the pumping facilities. Capability shall be provided for manual start-stop control for all pumping units, as well as the normal automatic control from the liquid level sensing and logic circuits. An automatic alternator shall change the starting sequence on each pump cycle. High water level alarm system with back up battery power shall be provided. Each sewage pump shall be provided with an elapsed time meter to indicate pump running time and phase protection. The submersible station controls shall be housed within an exterior panel; pylon mounted or free standing enclosure. The panel will be of Nema 3R weather tight construction, with hoop and padlock. A separate self-contained pull-box for all wiring SCADA ready shall be installed.

iv Submersible Pump Facilities

Sewage Pumping Stations of the submersible type are suitable where the peak design flow rate does not exceed 1,000 gallons per minute. Said installation shall include the removable pump units, aluminum access frame and cover, stainless steel pipe pump guide bars, bypass pump discharge connection, pressure gauges, and other necessary appurtenances. Individual discharge pipes shall extend from each pump to an accessible, well-protected and drained pit, in which the control and check valves shall be installed. The drainpipe from the pit to the wet well shall be valved on the inside of the pit. The pit and well openings shall be surrounded by a common four (4) inch thick reinforced concrete pad with the electrical panel supports secured in place. The submersible pumping system and accessories shall be as manufactured by Flygt Corporation, Norwalk, Conn., or approved equal.

H. Perimeter Fencing

All pumping stations shall have a 6-foot security type chain or privacy fence around their perimeters where necessary as determined by the Utility Director or his designee. Double six-foot wide access gates shall be provided to permit easy removal of equipment for maintenance. Plantings shall be required where aesthetics are a concern. A stabilized roadway with a minimum of 6" thick concrete shall be provided where the pumping station is not directly adjacent to a paved roadway. Filter fabric and #57 stone 4 inches deep are required throughout fenced area. Fenced area shall be equipped with water supply with reduced pressure zone vacuum breaker for wash down.

3. TESTING

A. General

Testing of pumping stations shall be done prior to acceptance of the project, which it services. Testing shall be witnessed by a representative of the City's Utility Department, project engineer, project contractor and lift station manufacturer.

B. Pumping Capacity

Pumping capacity shall be proven in the field after installation of pumping station. The designing engineer shall submit a letter stating test results.

SECTION 7

PIPE, PIPE FITTINGS, VALVES AND APPURTENANCES

1. GENERAL

A. This section includes the material and installation standards for pipe fittings, valves and appurtenances, as applicable to sewer and water installations.

B. Required specialty items not included under this section shall be high quality and consistent with approved standards of the industry for the applicable service installation and approved by the utility inspector.

2. PIPE AND PIPE FITTINGS

A. General

All pipe fittings shall be clearly marked with the name or trademark of the manufacturer. All pipe and fittings shall be suitable for 150 psi working pressure.

B. Cast and Ductile Iron

I Cast Iron pipe shall be in accordance with ANSI Standards A21.6. Pipe shall be laid in accordance with ANSI Standard A21.1. Thickness class shall be governed by design conditions.

ii Ductile Iron pipe shall be in accordance with ANSI/AWWA Standard C104/A21.4-85 C111/A21.11-85, C115/A21.15-88, C150/A21.50-81, ANSI/AWWA

C151/A21.51-86. A minimum class 50 pipe shall be supplied for all sizes. Pipe shall be laid in accordance with ANSI/AWWA Standard A21.50-81/C150. Thickness class shall be governed by design conditions.

- iii Cast and ductile iron pipe fittings shall conform to ANSI/AWWA Standard A21.53-88/C110.
- iv Joints
 - a.) "Push-On" and mechanical type joints shall be in accordance with ANSI/AWWA Standard A21.11-85/C111.
 - b.) Restrained joint assemblies for mechanical joint pipe shall be (U.S. Pipe Field-Lok Gasket Joint Restraint System) or ductile iron mechanical joint retainer glands, (Meg-Lug on DI pipe only) or (Grip Ring restraint assemblies.)
 - c.) Flange connections shall be in accordance with ANSI/AWWA Standard A21.15-88/C115.
- v Coatings and Linings
 - a.) Cast and ductile iron pipe and fittings for sewage service shall receive an interior and exterior bituminous coating as specified in ANSI Specifications A21.6, A21.8, or A21.51.

C. Polyvinyl Chloride (PVC)

I Potable Water

Pipe and fittings shall be manufactured from clean virgin compounds conforming to ANSI/AWWA C900-89 for nominal diameters 4 inch through 12-inch pressure pipe, and ANSI/AWWA C905-88 for nominal diameters 14 inch through 36 inch. The dimension ratio (DR) of 18 is to be used for construction of 4-inch through 12-inch potable water mains. The dimension ratio (DR) of 25 is to be used for construction of 14-inch through 36-inch potable water mains. PVC pipe for sizes 12 inch to 3 inch shall conform to ASTM D-2241 with minimum pressure Class 200, SDR 21.

ii Reclaimed Water

Reclaimed water mains shall conform to ASTM D-2241, SDR21 Pressure Class 900.

iii Sewer Force Mains

Sewer force mains shall conform to ANSI/AWWA C900, DR 25 or 26, CP100.

iv Sanitary Gravity Sewer

Gravity sewer mains must meet or exceed ASTM Standard D3034. A minimum DR 35 for gravity sewer mains will be required. All gravity lines shall have a smooth

bore in the flow line. All joints must be completely pushed home.

- v PVC pipe 4 inches and larger shall have integral bell push on type joints conforming to ASTM D3139. Pipe shall be extruded with integral thickened wall bells without decreasing the DR or SDR requirements of the pipe barrel.

D. Polyethylene Plastic Pipe

Pipe or tubing shall comply with AWWA C901/ASTM Designations D-1248 (Materials), D-2239 (Pipe) and D-2737 (Tubing), approved for potable water service by the National Sanitation Foundation and bear the NSF seal. The product shall be rated for a minimum working pressure of 160 PSI and the dimension ratio (DR) shall not exceed 11 for iron pipe size or 9 for copper tube size. Fittings shall be brass, equipped with compression type connections.

E. Special Items

I Tapping Saddles

Tapping saddles shall be fabricated of ductile iron and suitable for either wet or dry installation and shall be as manufactured by American Cast Iron Pipe Company or approved equal. The sealing gasket shall be the "O" Ring type suitable for the applicable service. Outlet flange shall be ANSI B16.1, 125 lb. standard. The straps and bolts shall be a corrosion resistant alloy steel. Minimum distance from a pipe joint to the center of a tap shall be three (3) feet.

ii Tapping Sleeves and Crosses

Shall be of mechanical joint type with outlet; flange ANSI B16.1, 125 lb. standard.

iii Service Saddles

A service saddle shall be used for all service line taps. Service saddles shall be double strap, anchored by a minimum four (4) bolt pattern on a ductile iron saddle body. Service saddles for PVC pipe shall have the double strap sized exactly to the pipe outside diameter. Sealing gaskets shall be BUNA-N rubber and straps shall be corrosion resistant alloy steel.

3. VALVES

A. General

The valve type, size rating, flow direction arrow if applicable, and manufacturer shall be clearly marked on each unit. Valves shall open left (counterclockwise) with an arrow cast in the metal of operation hand wheel and nuts indicating the direction of the opening.

I Valves for Underground Service

Valves shall be resilient-seated gate valves conforming to AWWA C509 non-rising stem type, and shall be equipped with 2-inch square cast iron wrench nuts. Underground service valves 2-inch or smaller shall meet the specifications of ANSI/AWWA C800-84. No wheel valves are allowed to be located below ground.

ii Valves for Above Ground Service

Shall be resilient-seated gate valves, conforming to AWWA C509, valves shall be outside screw and yoke (OS&Y) rising stem type. Valves shall have cast iron hand wheels or chain operators with galvanized steel chains, as required.

B. Check Valves

Valves shall be iron body, bronze mounted stainless steel hinge pin, outside lever and springs operated, swing type, and equipped with removable inspection covers. Units shall be rated for 150-psi minimum working pressure and shall permit full flow area equal to that of the connecting pipe.

C. Plug Valves (PV)

Valves shall be semi-steel body, non-lubricated, eccentric type, with resilient faced plugs, and capable of drip-tight shut-off at the rated pressure if applied at either port. Operation of all valves 10 inches or larger, and smaller sizes in exposed locations which require hand wheel or chain wheels, shall be by approved gear actuators, equipped with position indicator and stop, and shall be furnished by the valve manufacturer. Gear actuators for buried or submerged installations shall be furnished with sealed enclosures. Valves shall be equipped with actuating nuts, cast iron hand wheel or chain operators, with galvanized steel chains, as appropriate for the installation and type of operator.

D. Valve Boxes

Units shall be adjustable, cast iron, minimum interior diameter of 5 inches, with covers cast with the applicable inscription in legible lettering on the top; "SEWER" or "WATER". Boxes shall be suitable for the applicable surface loading and valve size. Valve boxes not in the pavement shall have around their tops reinforced concrete pads, which will be flush with the finished grade at valve

site (top of the curb or above if necessary) with minimum dimensions of 18 by 18 by 3 inches. Valve Boxes for reclaimed water shall have square lids with "RECLAIMED WATER" inscribed on the top.

4. INSTALLATION

A. General Requirements

- I Piping, fittings, valves and appurtenances shall be installed in accordance with these Standards.
- ii Piping shall be installed along straight line and grade between fittings, manholes, or other defined points, unless definite lines of alignment, deflection or grade change have been established. Pipes shall be pushed home to create a smooth flow line. Modification to approved alignment or grade during construction shall receive prior approval from the Utility Inspector and all resulting design considerations shall be resolved by the contractor.
- iii Materials shall be cleaned and maintained clean, with all coatings protected from damage. The interior of the pipe shall be free of dirt and debris, and when work is not in progress; all open ends shall be plugged.
- iv Pipe, valves, fittings, or other items shall be inspected prior to installation, and any items showing a fracture or other defect shall be rejected. However, cast or ductile iron pipe showing an end crack, with no fracture indicated beyond that visible, may be salvaged by cutting off the damaged section 12 inches past the defect, providing the remaining pipe is sound.
- v Underground piping shall not be driven to grade by striking it with an unyielding object. When the pipe has been properly bedded, enough compacted back-fill shall be placed to hold the pipe in correct alignment. If necessary, precaution should be taken to prevent flotation.
- vi Jointing shall be an approved method and shall not require undue force to accomplish full satisfactory seating and assembly. Connections at structures shall be cut accurately and worked into place without forcing and shall align with the connecting point.
- vii Underground pressure piping systems shall be thoroughly restrained at fittings, valves and plugs with approved restraint joint assemblies. Fittings shall not be encased in concrete.
- viii Subaqueous pipe laying may be permitted where conditions make it impractical to lay pipe in the "dry", provided the contractor submits his plans for laying pipe under water to the Utility Department and obtains advance approval thereof.
- ix Disinfecting all potable water pipes shall be accomplished by the contractor following approved pressure testing. Unless alternate procedures are set forth under the applicable service Standard, said disinfecting procedures shall be in accordance with AWWA Standard C601.

- x Cast and Ductile Iron Pipe (CI & DI) installation shall be performed in accordance with the applicable provisions of AWWA Standard C600.
- xi Asbestos-Cement (AC) The use of asbestos cement pipe is not acceptable.
- xii Polyvinyl Chloride (PVC) pipe-lubrication and/or solvent for pipe and fitting joints shall be non-toxic (NSF approved for potable water). Following making, solvent type joints shall not be disturbed for 5 minutes and shall not have internal pressure applied for 24 hours, or as recommended by the pipe manufacturer.

5. PIPELINE IDENTIFICATION

A. General Requirements

- I Pipe line identification locator wire is to be installed on all potable water, reclaimed water and sewer force mains. Locator wire shall be 14 gauge solid copper UP, 600 volt with insulating jacket, laid on top of and secured to the main with tape a minimum of every five feet. The locator wire shall be installed continuously over the entire length of the mains. Valve boxes shall be used as junction points where access to the locator wires can be made without having to excavate. Valve boxes shall be placed no greater than 500 feet apart.
- ii Adhesive Buried Piping Identification Tape shall be installed on all buried potable, reclaimed water, sewer and force mains that are not color coded PVC. The tape shall be inert plastic film specifically formulated for prolonged underground use and shall have appropriately printed wording identifying the type of pipe. Lettering size shall be a minimum of one inch. The minimum thickness shall be four mils and the overall width shall be six inches. The tape shall be the standard product of a manufacturer regularly engaged in the supply of this material and shall have an adhesive backing for attachment to DIP or PVC pipe and lettering shall be continuous.
- iii The City adopts the following pipe color codes for PVC pipe.
 - a.) Blue: All PVC potable water mains.
 - b.) Purple: All PVC reclaimed water mains and polyethylene plastic service lines.
 - c.) Green: All PVC sanitary sewer mains.
 - d.) Green: All PVC sanitary sewer force mains.

SECTION 8

UTILITY EXCAVATION, TRENCHING AND BACKFILLING

1. GENERAL

The provisions set forth in this section shall be applicable to all underground sewer and water piping installations, regardless of location, unless prior approval is received from the Utility for special design considerations.

2. MATERIALS

Steel sheeting shall be used for trench shoring.

3. WORKMANSHIP

A. Trench Dimensions

The minimum width of the trench shall be equal to the outside diameter of the pipe at the joint plus 8 inches for un-sheeted trench, or 12 inches for the sheeted trench, and the maximum width of trench, measured at the top of the pipe, shall not exceed the outside pipe diameter plus 2 feet, unless otherwise shown on the drawing details, or approved by the Utility Director.

B. Utility Bedding

I Class B (Minimum Utility Bedding): The bottom of the trench shall be shaped to provide a firm bedding for the pipe. The pipe shall be firmly bedded in undisturbed firm soil, or hand shaped unyielding material. The bedding shall be shaped so that the pipe will be continuous therewith for its full length.

ii Class A (Special Utility Bedding): Should special bedding be required due to depth of cover, impact loading, or other conditions, "Class A" bedding shall be installed.

C. Unsuitable Material Below Trench Grade

Soil unsuitable for a proper foundation encountered at or below trench grade, such as muck or other deleterious material, shall be removed for the full width of the trench and to the depth required to reach suitable foundation material, unless special design considerations received prior to approval from the City. Backfilling below trench grade shall be in compliance with the applicable provisions of subsection 3-K "Backfill".

D. Extra Utility-Bedding Material

When rock or other non-cushioning material is encountered at trench grade, excavation shall be extended to 6 inches below the outside of the bottom of the utility, and a cushion of sand shall be provided.

E. Sheeting and Bracing

In order to prevent damage to property, injury to persons, erosion, cave-ins, or excessive trench widths, adequate sheeting and bracing shall be provided in accordance with standard practice.

F. Excavated Material

Excavated material to be used for backfill shall be neatly deposited at the sides of the trench where space is available. Where stockpiling of excavated material is required, the contractor shall be responsible for obtaining the sites to be used.

G. Material Disposal

Excess, unsuitable, and cleared or grubbed material resulting from the utility installation, shall be removed from the work site and disposed of at locations secured by the contractor. Excess excavated material shall be spread on the disposal site and graded in a manner to drain property and not disturb existing drainage conditions.

H. Borrow

Should there be insufficient satisfactory material from the excavations to meet the requirements for fill material, borrow shall be obtained from pits secured by the contractor.

I. Dewatering

Utilities shall be laid "in the dry" unless otherwise approved. Dewatering system shall be utilized in accordance with good standard practice and must be efficient enough to lower the water level in advance of the excavation and maintain it continuously to keep the trench bottom and sides firm and dry.

J. Obstructions

It shall be the contractor's responsibility to acquaint themselves with all existing conditions and to locate all structures and utilities along the proposed utility alignment in order to avoid conflicts. Where actual conflicts are unavoidable, work shall be coordinated with the facility owner and performed so as to cause as little interference as possible with the service rendered by the facility disturbed.

K. Backfill

- I Backfill material shall be clean earth fill composed of sand, sand and rock, crushed rock, or an approved combination thereof.
- ii When trenches are cut in pavement or areas to be paved, compaction as determined by AASHO Specification T-180, shall be equal to 98 percent of maximum density, with compaction in other areas not less than 95 percent of maximum density.
- iii If, in the opinion of the Utility Director, densities are questionable, a testing laboratory approved by the Utility Director at the expense of the contractor shall make density tests for determination of the above-specified compaction. The Utility Director will determine test locations.
- iv Protective concrete slabs shall be installed over the top of trenches, where required, to protect the installed pipe against excessive loads.
- v Existing sidewalks and driveways removed, disturbed, or destroyed by construction, shall be replaced or repaired.

L. Roadway and Pavement Restoration

- I Pavement or roadway surfaces cut or damaged shall be replaced by the contractor in equal or better condition than the original, including stabilization, base course, surface course, curb and gutter, or other appurtenances. The contractor shall obtain the necessary permits and all applicable authorizations from the proper agencies prior to any roadwork. Additionally, the contractor shall provide advance notice to the appropriate authority, as required, prior to construction operations.
- ii Restoration shall be in accordance with requirements set forth by the City Engineer or approved equal. The materials of construction and method of installation, along with the proposed restoration design for items not referred to or specified herein, shall receive prior approval from the department.
- iii Where existing pavement is removed, the surfacing shall be mechanically saw cut prior to trench excavation, leaving a uniform and straight edge, with minimum disturbance to the remaining adjacent surfacing. The width of shall be minimal.
- iv Immediately following the specified backfilling and compaction, a temporary sand seal coat surface shall be applied to the cut areas. This temporary surfacing shall provide a smooth traffic surface with the existing roadway and shall be maintained until final restoration.

M. Protection and Restoration of Property

During the course of construction, the contractor shall take special care and provide adequate protection in order to minimize damage to vegetation, surface areas, and structures

within the construction of right-of-way, easement or site, and take full responsibility for the replacement or repair thereof.

N. Clean-up

Work site clean up and property restoration shall follow behind construction operations without delay. No site will be accepted until sod is fully reestablished.

SECTION 9

CASING PIPE-BORING AND JACKING

1. GENERAL

- A. The provisions of this section shall be the minimum standards for the installation of casing pipe by the boring and jacking method of placement of sewer and water pipelines.
- B. In general, all underground pipelines crossing existing major City and Seminole County roadways, Florida State highways, and railroads shall be installed under these traffic ways within bored and jacked steel casing pipe. Specific crossing requirements shall be obtained in advance from the authority having jurisdiction.
- C. It shall be the responsibility of the contractor to submit the necessary permit documents and data to the appropriate authority and receive approval thereof.

2. CASING PIPE MATERIALS AND INSTALLATION

A. Dimensions and Materials

Casing pipes crossing under roadways shall be located at suitable approved alignments in order to eliminate possible conflict with existing or future utilities and structures, with a minimum 36 inches depth of cover between the top of the casing pipe and surface of the roadway where practicable. Casings shall be new prime steel pipe conforming to the requirements of ASTM Designation A-139. The minimum casing pipe size and wall thickness shall be as shown in the following table for the sewer or water carrier pipe size indicated.

<u>Carrier Pipe (Nominal Size-Inches)</u>	<u>Casing Pipe (Outside Diameter Inches)</u>	<u>Casing Pipe (Wall Thickness Inches)</u>
-		-
4"	16"	0.250"
6"	18"	0.250"
8"	20"	0.250"
10"	24"	0.250"
12"	30"	0.312"
16"	32"	0.312"
18"	34"	0.312"
20"	36"	0.375"
24"	42"	0.500"

B. Areas Not Under Jurisdiction

For casing pipe crossings under roadways, railroads, or other installations not within the jurisdiction of the City of Winter Springs, the contractor shall comply with the regulations of said authority in regard to design, specifications and constructions.

C. Workmanship

I The boring and jacking operations shall be done simultaneously with continuous installation, until the casing pipe is in final position. Correct line and grade shall be carefully maintained. Add-on sections of casing pipe shall be full-ring welded to the preceding length, developing watertight total pipe strength joints. The casing installation shall produce no upheaval, settlement, cracking, movement or distortion of the existing roadbed or other facilities. Following placement of the carrier pipe within the steel casing, masonry plugs or rubber boots are to be installed at each open end.

ii Casing pipe holes shall be mechanically bored through the soil by a cutting head on a

continuous auger mounted inside the pipe. The auger shall extend a minimum distance beyond the end of the pipe casing to preclude formation of voids outside of the pipe shell.

- iii The casing pipe shall be adequately protected to prevent crushing or other damage under jacking pressures.
- iv Required boring and jacking pits or shafts shall be excavated and maintained to the minimum dimension. Said excavations shall be adequately barricaded, sheeted, braced and dewatered as required.

APPENDIX

LIST OF MATERIALS AND APPROVED MANUFACTURERS

This list is to be used as a guide only. Manufacturers or materials not contained on this list must be approved by the utility inspector. This list is conditional to utility inspector's approval and is subject to change.

1. WASTEWATER MAIN MATERIALS

<u>ITEM</u>	<u>MANUFACTURERS</u>	<u>PART NO.</u>
AIR RELEASE VALVES	1. ARI 2. Vent-O-Mat 3. Crispin	1. D-040 2. RBX 3. X Series
AIR RELEASE/VACUUM RELIEF VALVES	1. ARI 2. Vent-O-Mat 3. Crispin	1. D-20S; d-25; D-25 L; D-25 ST 2. RGX 3. X Series
CASING SPACERS	1. Cascade 2. PSI 3. Power Seal 4. Advance Products	1. CCS-12" Width Min. 2. C12G-2 3. Model 4810 4. SS 8, SS 12
CHECK VALVES (4" & LARGER)	1. Kennedy 2. APCO 3. Mueller 4. Clow 5. American Flow Control	1. Kenflex 2. Series 100 3. A-2600 4. Series 2745 5. Series 2100
EXPANSION JOINTS	1. Mercer 2. Metroflex 3. EBBA Iron	
FITTINGS(DI)	1. Union/Tyler 2. U.S. Pipe 3. NAPPCO 4. American 5. Sigma	

6. Griffin

PRECAST MANHOLES

- 1. Atlantic Precast
- 2. Mack Precast
- 3. Standard Precast
- 4. Southern Precast
- 5. Allied Precast

MANHOLE FRAME AND COVER

- 1. U.S. Foundry
- 2. Vulcan

- 1. USF #225-AS
- 2. V1357

MANHOLE JOINTING MATERIAL

- 1. K.T.Snyder Co.
- 2. Conseal

- 1. Ram-Nek
- 2. CS102

MANHOLE SURFACE COATINGS

- 1. Permite
- 2. Sauereisen
- 3. Aquata Poxy

- 1. PCS-9043 TypeII
- 2. 210

A. PAINTING: AERIAL PIPING, FITTINGS & VALVES

FIELD PRIMER

- 1. Porter/Int'l
- 2. Tnemec
- 3. Glidden

- 1. 284 U-Primer
- 2. Chem-prime H.S. Series 37H
- 3. ALKYD Ind. Enamel

FINISH(EXTERIOR)

- 1. Porter/Int'l
- 2. Tnemec
- 3. Glidden

- 1. 2410 Alkyd Gloss
- 2. Tnemec-Gloss Series 2H
- 3. Alkyd. Ind. Enamel

PIPE(DI)

- 1. American
- 2. McWane
- 3. U.S. Pipe
- 4. Griffin

PIPE (PVC) GRAVITY

1. Certain Teed
2. Can-Tex
3. CPS
4. J-M
5. Napco
6. National
7. Diamond Plastics

PLUG VALVES

- | | |
|--------------|--------------------|
| 1. Val-Matic | 1. 5800, 5900 |
| 2. M & H | 2. 1820 |
| 3. Dezurik | 3. Series Pec |
| 4. Clow | 4. F-5412, F-5413 |
| 5. Crispin | 5. Series 800, 900 |
| 6. Pratt | 6. PV |

RESTRAINED JOINTS

- | | |
|--------------------|------------|
| 1. Ebba Iron, Inc. | 1. Megalug |
| 2. Star | 2. Allgrip |

TAPPING SLEEVES,
STAINLESS STEEL

- | | |
|-----------------------------|--------------------|
| 1. Smith Blair/
Rockwell | 1. Series 663 |
| 2. Romac | 2. Series STS 420 |
| 3. JCM | 3. Series 432, 452 |
| 4. Ford | 4. FTSS |

TAPPING SLEEVE, MJ

- | | |
|-----------------------------|-----------|
| 1. U.S. Pipe | 1. T-9 |
| 2. Mueller | 2. H-615 |
| 3. Clow | 3. F-5205 |
| 4. American
Flow Control | 4. 2800 |
| 5. M & H | 5. 1574 |

TAPPING VALVES

- | | |
|--------------------------|-----------------------|
| 1. Kennedy | 1. Series 475 |
| 2. M & H | 2. Series 475 |
| 3. American Flow Control | 3. Series 2500 |
| 4. U.S. Pipe | 4. Series TUSP0/TUSP1 |
| 5. Clow | 5. F-6114 |
| 6. Mueller | 6. T2360/T2361 |

VALVE BOXES

1. Tyler
2. U.S. Foundry
3. American Flow Control

VAULT FRAME & COVER
FOR AIR RELEASE

/VACUUM RELIEF
VALVES

1. U.S. Foundry

1. USF 7665

2. WASTEWATER PUMP STATION MATERIALS

GENERATOR CIRCUIT
BREAKERS

1. Square D
2. Westinghouse

GENERATOR SYSTEMS

1. Tradewinds
2. Caterpillar
3. Onan(Cummins)

PRESSURE GAUGES

1. Ashcroft
2. H.O. Trerice Co.
3. Dwyer

SUBMERSIBLE PUMPS

1. Flygt
2. Grundfoss

WETWELL ACCESS
FRAMES AND COVERS

1. Halliday Products, Inc.
2. Bilco Co.
3. U.S. Foundry

CONTROL PANELS(CP)

1. Sta-Con, Inc.
2. E- Controls
3. Curry Controls

ALARM HORN(AH)

1. Edwards
2. Wheelock

1. 870-N5
2. 3IT-115-R

ALARM LIGHT

1. American Electric
2. Red Dot

1. F32552
2. 866 B

CONTROL CIRCUIT
BREAKER

1. Square D
2. Westinghouse

1. QOU120
2. BAB1020

CONTROL CIRCUIT
TRANSFORMER

1. Square D
2. Westinghouse

1. EO-18
2. IF3053

DUPLEX
RECEPTACLE/GFI(DR)

1. Square D
2. Hubbel

1. GF5R-115-1C
2. GF-52621

ELAPSE TIME METER(ETM)

1. Engler
2. Hecon

1. AC-200-10NG7
2. T0621134

EMERGENCY CIRCUIT

1. Square D

		2. Westinghouse	
ENCLOSURE		1. Hoffman 2. Tanco	
FUSES(F)		1. Bussmann 2. Gould-Shawmut	
FLASHER(FL)		1. Sta-Con, Inc. 2. SSAC	1. 008-24-13SP 2. FS-126
FLOAT REGULATOR(FR)		1. Roto-Float (Non Mercury)	
GENERATOR			
RECEPTACLE(GR)(Male)		1. Pyle National 2. Crouse-Hinds 3. Crouse-Hinds	1. JRE-4100 2. AR2042-S22 3. AR2042
	1. 230V, 100A, 3P, 4W 2. 460V, 200A, 3P, 4W 3. 230V, 200A, 3P, 4W		
HAND-AUTO-OFF- SELECTOR(HOA)		1. Square D 2. Westinghouse	1. 9001-SKS 2. PB1HOA
HORN BUTTON(HSS)	SILENCE	1. Square D 2. Westinghouse	1. 9001-SKR-1U 2. PB1HAA
MAIN BREAKER(MCB)	CIRCUIT	1. Square D 2. Westinghouse	
MAIN TRANSFORMER(MCT)	CIRCUIT	1. Square D 2. Westinghouse	1. 500SV43F 2. S10N04A51M
MOTOR BREAKER(MB)	CIRCUIT	1. Square D 2. Westinghouse	
MOTOR STARTER(MS)		1. Square D 2. Westinghouse 3. Furnas	1. D-8536 2. A-200 3. ESP-100
OVERLOAD HEATER(OL)		1. Square D 2. Westinghouse 3. Furnas	

PHASE MONITOR(PM)	1. MPE 2. Diversified	
PILOT LIGHT(PL)	1. Dialco 2. Littelfuse	1. 803-1710 2. 930407X
RELAY(R)	1. Snyder 2. Porter Brumfield 3. Eagle Signal	1. 2. KRPA-11AN 3. 22 Series
RESISTOR(RE) 5 watt, 2500 ohm	1. Rockwood	
RUN INDICATOR (RL)	1. Dialco 2. Littelfuse	1. 803-1710 2. 930407X
SURGE PROTECTOR(LA)	1. EDCO 2. Phoenix Contact	
TERMINAL STRIP(TS)	1. Square D 2. Phoenix 3. Marathon	1. 9070-GR6 2. 3. Series 200

III. WATER MAIN MATERIALS

AIR RELEASE VALVES	1. ARI 2. Vent-O-Mat 3. Crispin	1. D-040 2. RBX 3. X Series
BUTTERFLY VALVES	1. Clow 2. Mueller/Pratt 3. M & H 4. Millikin 5. Dezurik	1. 4500, 1450 2. Linseal III/BV 3. 4500 4. 500 5. BAW
CASING SPACERS	1. Cascade 2. PSI 3. Power Seal 4. Advance Products	1. CCS-12"W Min. 2. C12G-2 3. Model 4810 4. SS8 & SS12
CORPORATION STOPS (BALL TYPE)	1. Ford 2. Mueller	

CURB STOPS (BALL TYPE)	1. Ford	
EXPANSION JOINTS	1. Mercer 2. Metraflex 3. EBBA Iron	
FIRE HYDRANTS	1. Mueller 2. American 3. Clow	1. Super Centurion 2. B 84 B-6" 3. Medallion F-2545
FITTINGS	1. McWane 2. U.S. Pipe 3. American 4. Tyler	
GATE VALVES (12" & SMALLER) RESILIENT SEATED ONLY	1. Clow 2. Mueller 3. U.S. Pipe 4. American Flow Control 5. M & H 6. Kennedy 7. American AVK Co.	1. F6100 2. A-2360/A2361 3. AUSP0/AUSP1 4. Series 2500 5. Series 3067 6. Series 4571 7. Series 25
PAINTING: AERIAL PIPING, FITTINGS & VALVES		
PIPE(DI)	1. American 2. McWane 3. U.S. Pipe 4. Griffin	
PIPE(PVC)	1. Certain Teed 2. Freedom Plastics 3. Griffco 4. IPEX 5. Napco 6. National 7. Diamond Plastics	
POLYETHYLENE TUBING	1. Endot Endopure 2. ADS 3. Charter Plastics	1. PE-4710 2. Blue Ice (PE-4710) 3. Polyflex

RESTRAINED JOINTS
(DUCTILE IRON PIPE)

1. EBBA Iron, Inc.

1. Mega-Lug 1100
(3"-48")
Mega-Lug 1100 HD
(10"-48")
Mega-Lug 2100
Flange Adapter

2. Uni-Flange

2. 1350 Bell Rest.
(2"-12")
1360 Bell Rest.
(4"-8")(14"-24")
900 Adapt. Flange
(4"-12")
1300 Fitting Res-
trainer(14"-24")

3. US Pipe

3. Field LOC Gasket

4. Romac Industries

4. Grip Ring Series
611,612,613

SERVICE SADDLES

1. Smith Blair

1. 317,
397

2. Ford

2. FCD-202

3. JCM

3. 406

4. Mueller

4. DR2S,
DR2SOD

5. Romac

5. 202N

TAPPING SLEEVES,
FABRICATED STEEL

1. Smith Blair
(Rockwell)

1. 622-031

2. JCM

2. 412 ESS

3. Baker

3. 428 FS

4. Ford

4. FTSC Fast

5. Water Works

5. CT-790 FS

6. Mueller

6. H-624

7. Romac

TAPPING SLEEVES, M.J.

- 1. U.S.Pipe
- 2. Mueller
- 3. Clow
- 4. M & H
- 5. American Flow Control
- 6. Ford
- 7. Smith Blair

- 1. T-9
- 2. H-615/H624
- 3. F-5205
- 4. 1174
- 5. 2800

TAPPING VALVES

- 1. Kennedy
- 2. M & H
- 3. American Flow Control
- 4. Waterous
- 5. U.S. Pipe
- 6. Clow
- 7. Mueller
- 8. American AVK Co.

- 1. 4950
- 2. 3751
- 3. 2500
- 4. Series 800
- 5. Metroseal 250/5860
- 6. G6114
- 7. H-687
- 8. Series 25

VALVE BOXES

- 1. Tyler
- 2. US Foundry

3. American Flow Control

VAULT FRAME AND COVER FOR AIR RELEASE VALVES

- 1. U.S. Foundry

- 1. USF 7665

"U" BRANCH

- 1. Ford
- 2. Mueller
- 3. McDonald

STRAIGHT METER VALVE

- 1. Ford

City of Winter Springs
Detail Drawings

DUCTILE IRON POTABLE WATER MAIN

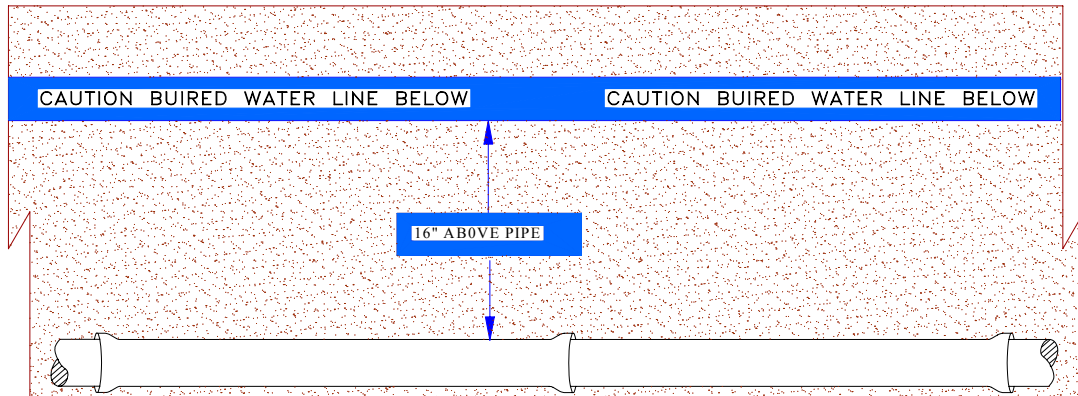
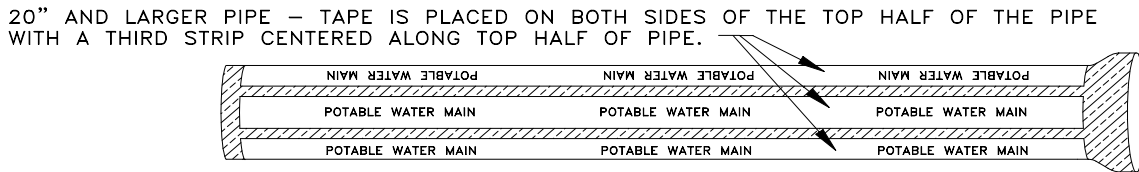
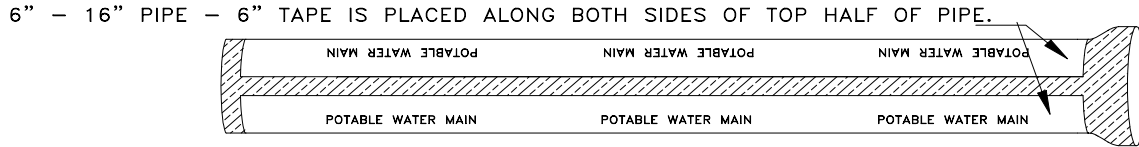
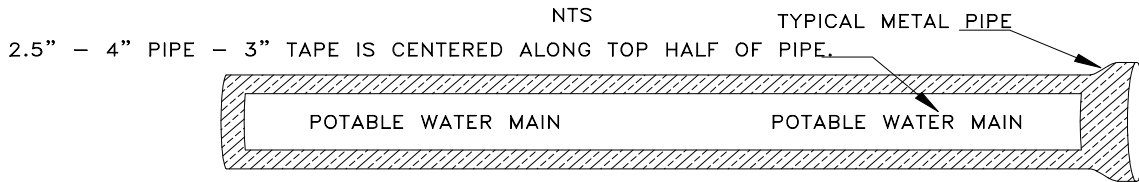

NOTE;

- Standard Non-Detectable Warning Tape
- Water Line Tape is 3" Wide and Blue With Black Lettering
- Sewer Line Tape is 3" Wide and Green With Black Lettering
- Force Main Tape is 3" Wide and Brown With Black Lettering

W.S. DETAIL 6-9-00 BY DT

PIPE IDENTIFICATION AND WARNING TAPE

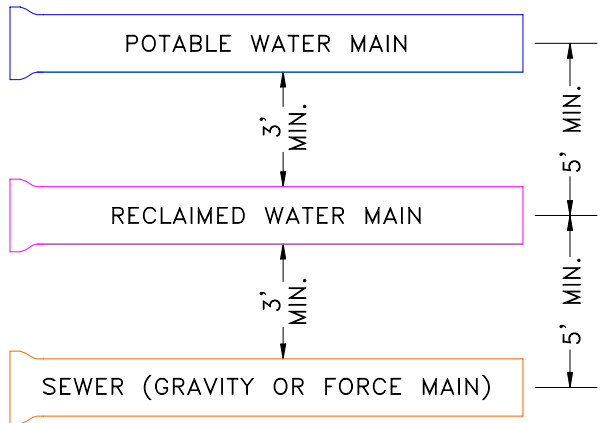

A MINIMUM HORIZONTAL SEPARATION OF 5' (CENTER TO CENTER) OR 3' (OUTSIDE TO OUTSIDE), SHALL BE MAINTAINED BETWEEN RECLAIMED WATER LINES AND EITHER POTABLE WATER MAINS OR SEWER COLLECTION LINES.

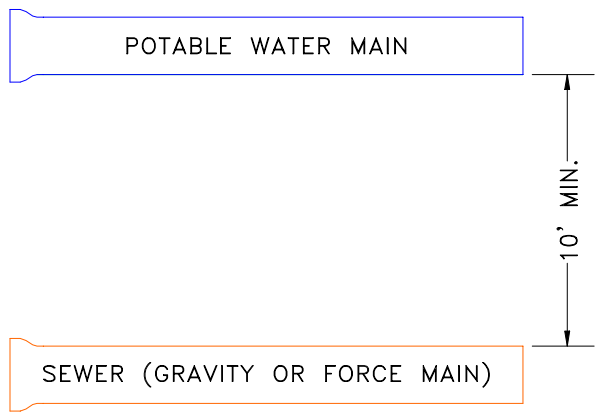

A MINIMUM HORIZONTAL SEPARATION OF 10' (OUTSIDE TO OUTSIDE), SHALL BE MAINTAINED BETWEEN SEWER COLLECTION LINES AND POTABLE WATER MAINS.

MINIMUM HORIZONTAL SEPARATION REQUIREMENTS
FOR POTABLE, RECLAIMED, AND SEWER LINES

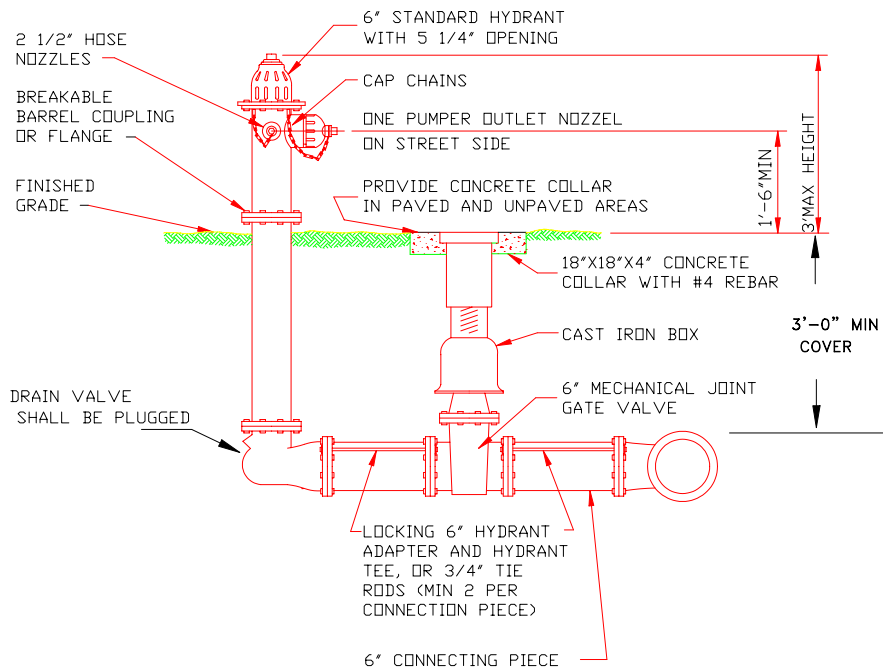

NOTES:

1. THE HYDRANTS ACCEPTABLE TO THE CITY OF WINTER SPRINGS SHALL BE EITHER THE CLOW # 42 MEDALION AMERICAN DARLING B84B, OR THE MUELLER A-423.
2. THE BARREL SHALL BE PAINTED YELLOW AND TOP WHITE
3. GRIP RING OR MEGA LUG RESTRAINTS MAY USED IN PLACE OF ALL THREAD RODS



FIRE HYDRANT ASSEMBLY

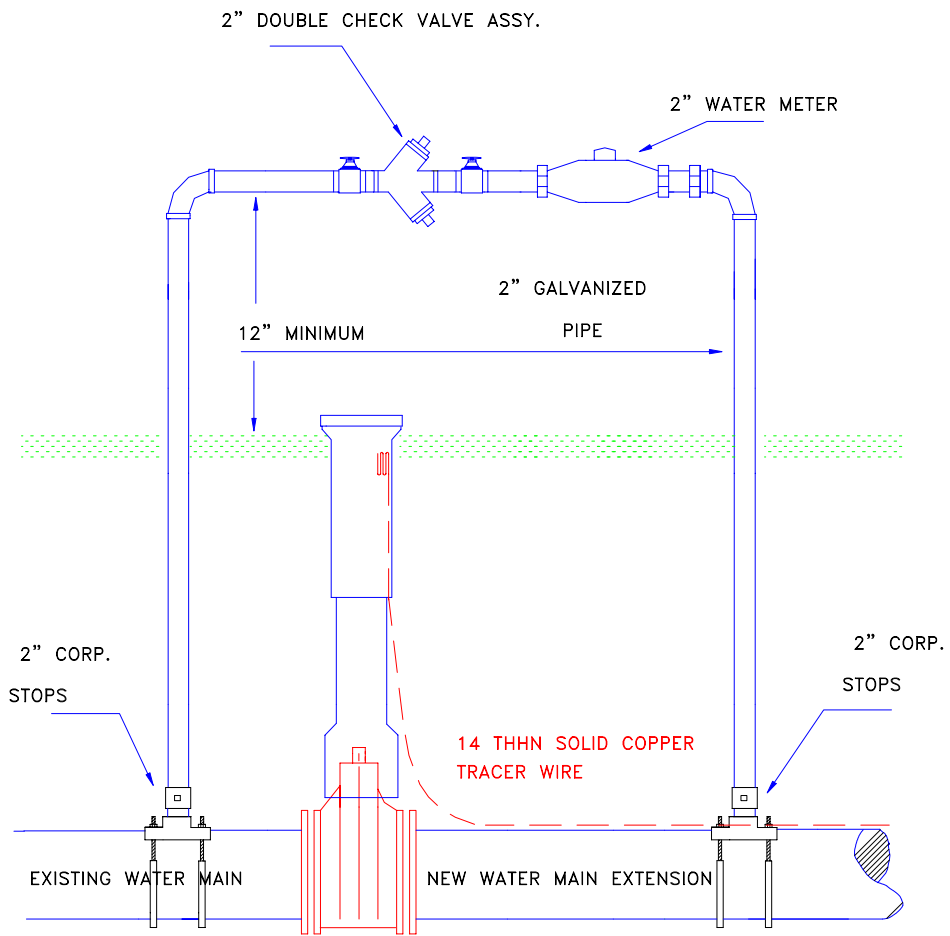

TEMPORARY BYPASS

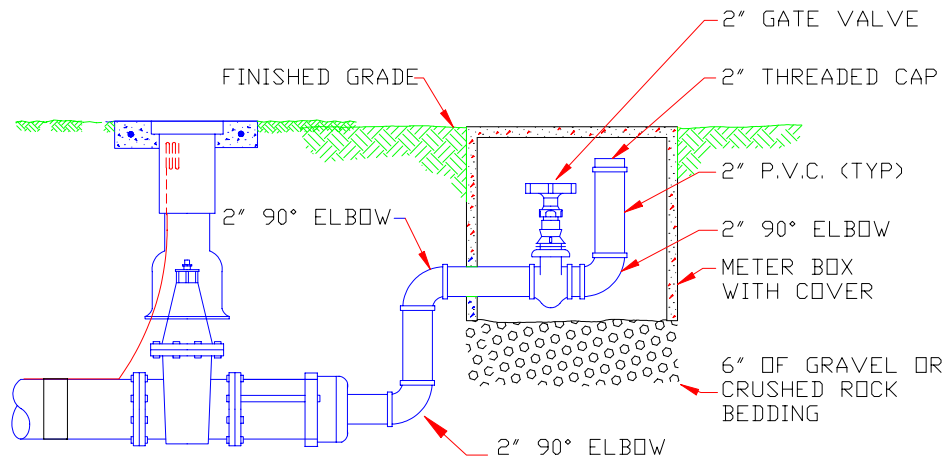

NOTE:

ALL PIPE AND FITTINGS MUST BE GALVANIZED IRON PIPE OR SCHEDULE 80 P.V.C.

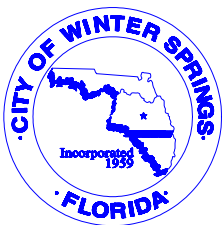

BLOWOFF VALVE

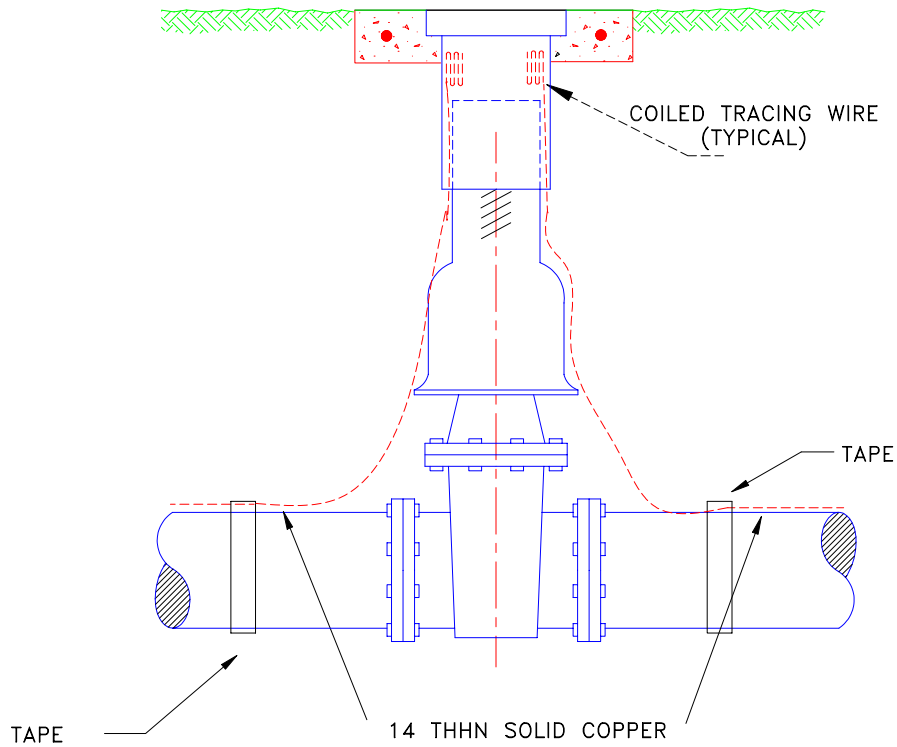

TRACING WIRE GENERAL NOTES:

1. PIPE LINE TRACING WIRE IS TO BE INSTALLED ON ALL POTABLE WATER RECLAIMED WATER AND SEWER FORCE MAINS.
2. SYSTEMS—TRACING WIRE SHALL ALLOW TRACABILITY OF ALL PIPE BRANCHES INCLUDING THOSE FOR HYDRANTS. TRACING WIRE SHALL BE INSTALLED OVER THE ENTIRE LENGTH OF THE MAIN AND SECURED TO THE MAIN EVERY 5 FEET WITH ADHESIVE TAPE. WIRE SHALL EXTEND A MINIMUM OF 12" ABOVE GRADE AT EACH INTERVAL AND SHALL BE COILED AND PLACED IN A VALVE BOX FOR EASY ACCESSIBILITY.
3. ON DEAD END MAINS THE TRACING WIRE SHALL BE PLACED IN A PROPERLY IDENTIFIED PVC VALVE BOX AT THE END OF THE RUN.

TRACING WIRE CONNECTION

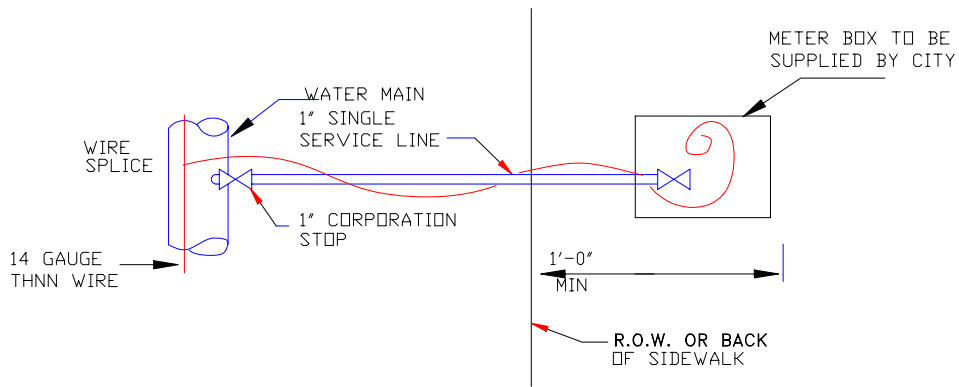

PLAN

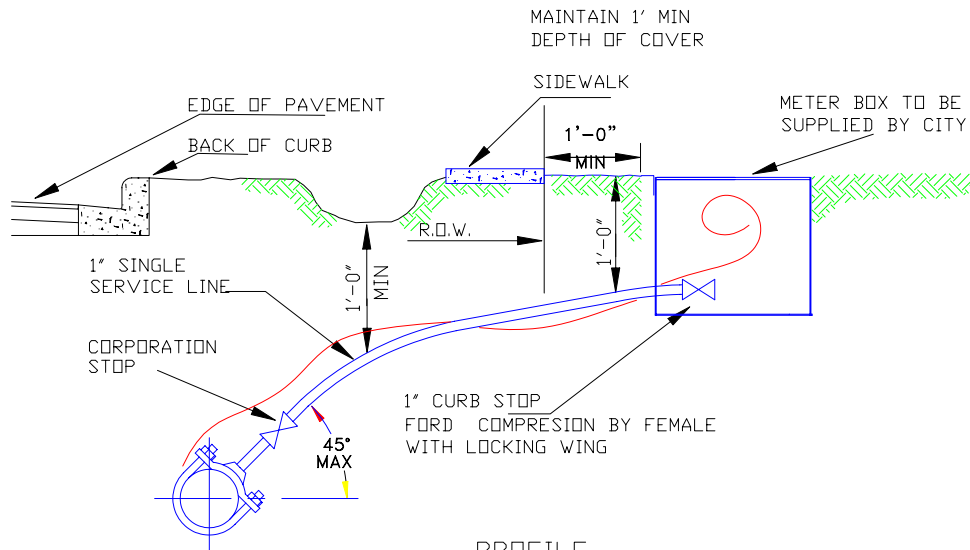

PROFILE

NOTES:

1. METER BOX INSTALLED BY THE CITY OF WINTER SPRINGS
2. METER PURCHASED FROM AND INSTALLED BY THE CITY OF WINTER SPRINGS

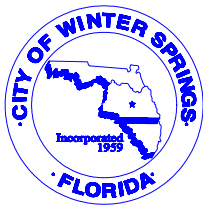

POTABLE WATER SERVICE SINGLE

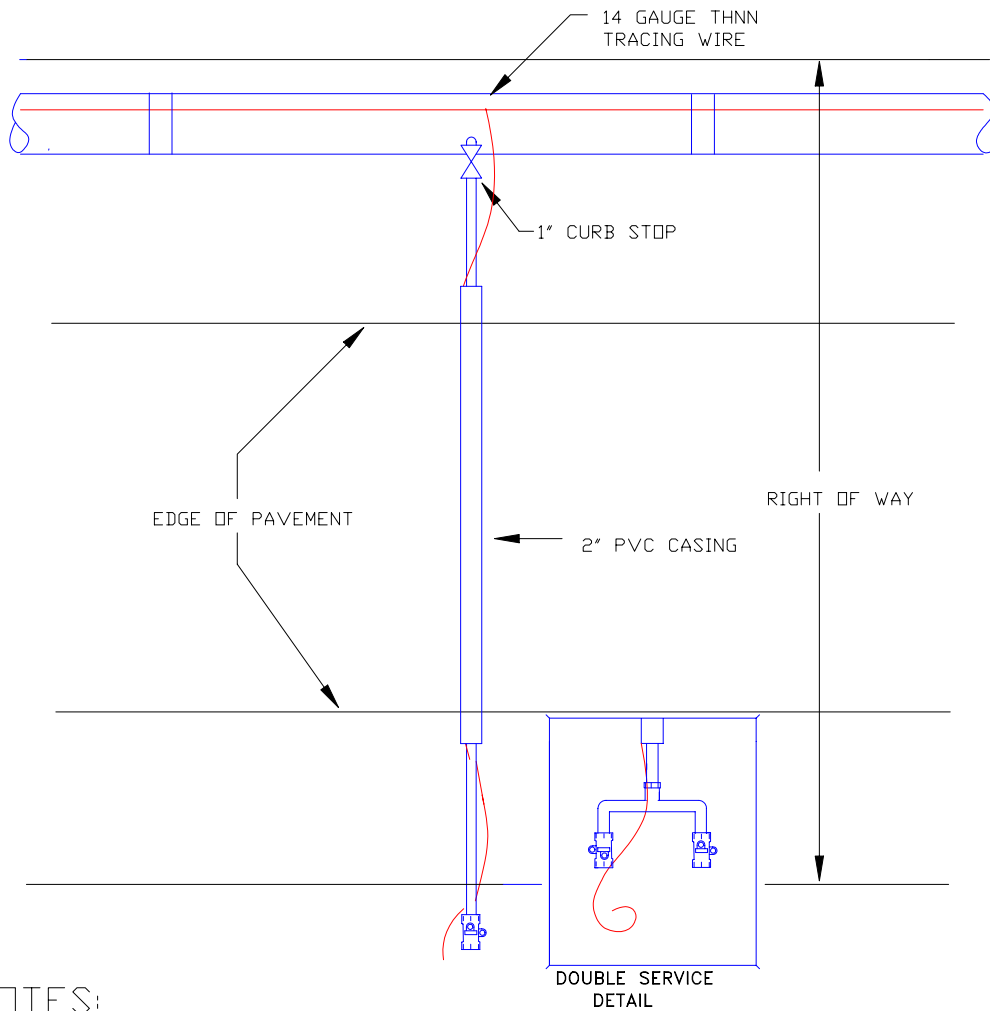

NOTES:

1. METER BOX INSTALLED BY THE CITY OF WINTER SPRINGS
2. DOUBLE SERVICE LINES SHALL BE 1" P.E TUBING
3. ALL LINES UNDER PAVEMENT SHALL BE ENCASED IN 2" PVC PIPE



POTABLE WATER SERVICE
OPPOSITE SIDE OF MAIN

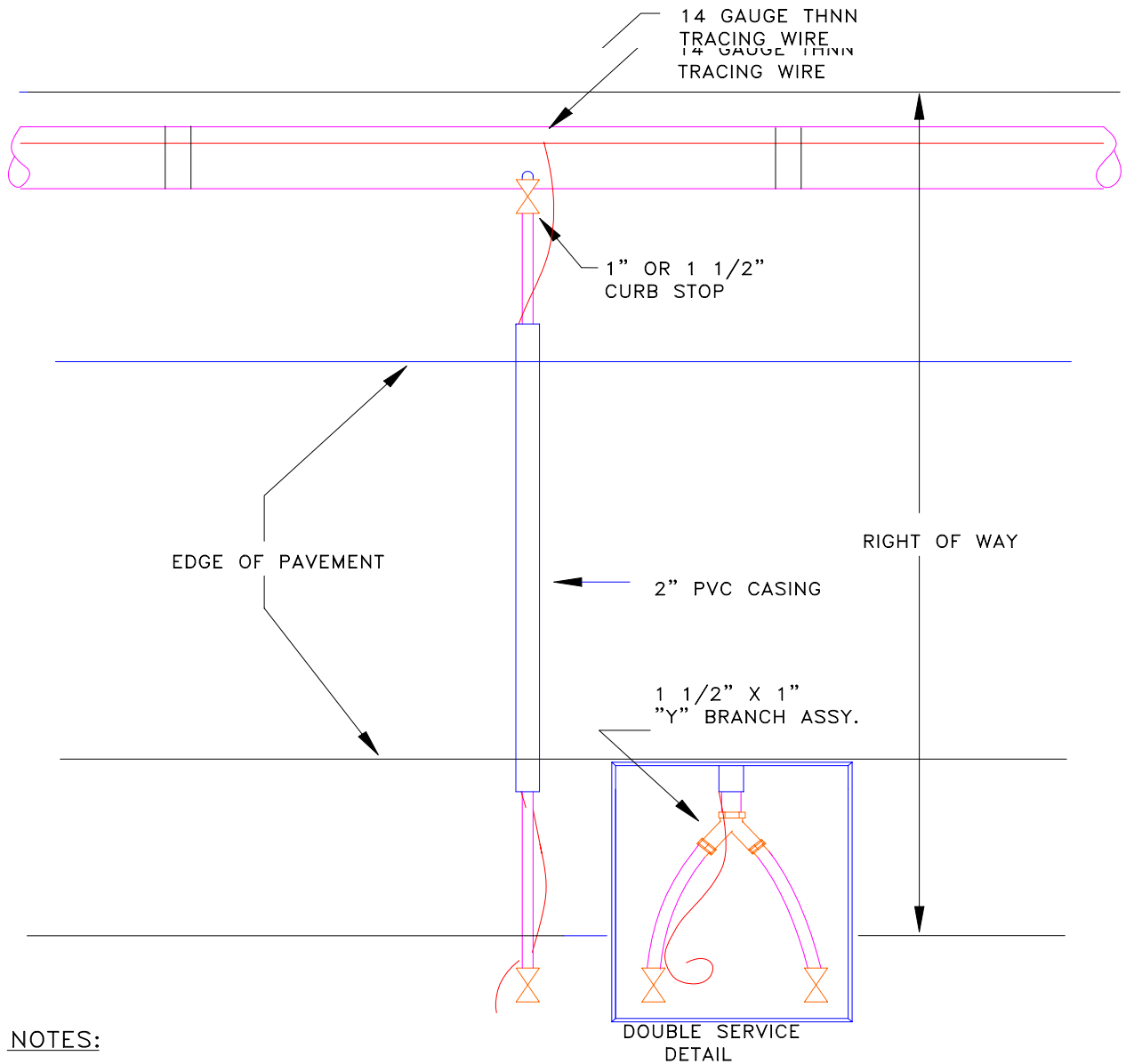

NOTES:

1. METER BOX INSTALLED BY THE CITY OF WINTER SPRINGS
2. DOUBLE SERVICE LINES SHALL BE 1 1/2" PURPLE P.E TUBING WITH 1 1/2" X 1" Y BRANCH
3. ALL LINES UNDER PAVEMENT SHALL BE ENCASED IN 2" PVC PIPE

1" RECLAIMED WATER CURB STOP TO BE INSTALLED BY CONTRACTOR ON ALL RECLAIMED SERVICE LINES

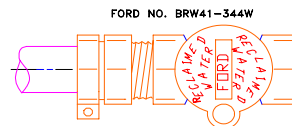

AWWA C901-88 PE 3408 POLYETHYLENE TUBING

RECLAIMED WATER SERVICE CONNECTION

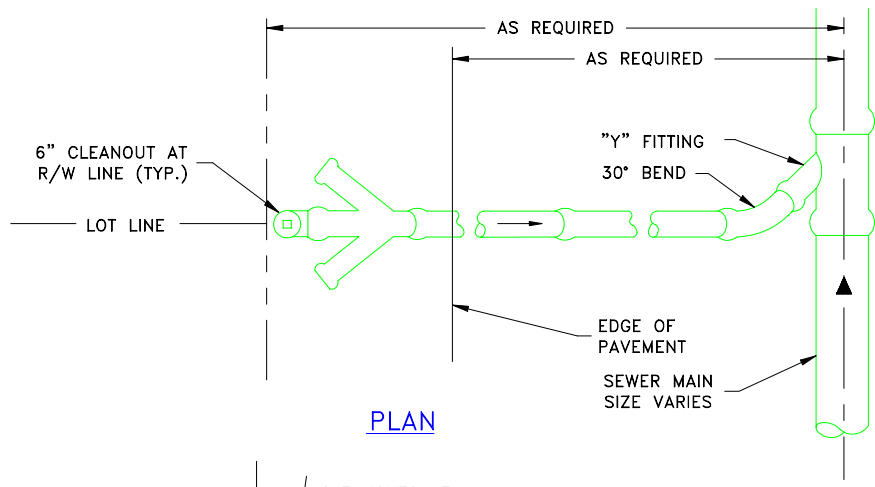

PLAN

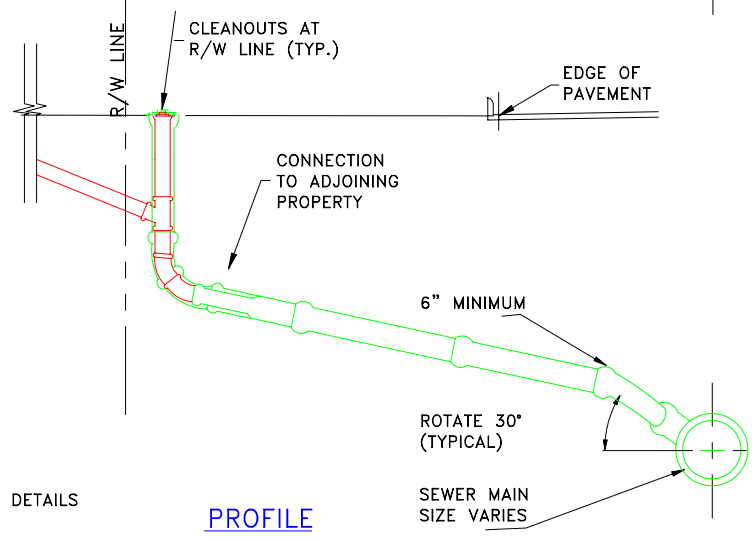

PROFILE

NOTE:
 SERVICE CONNECTION DETAILS
 FOR P.V.C. PIPE

09-24-98

DOUBLE SERVICE SEWER LATERAL CONNECTION

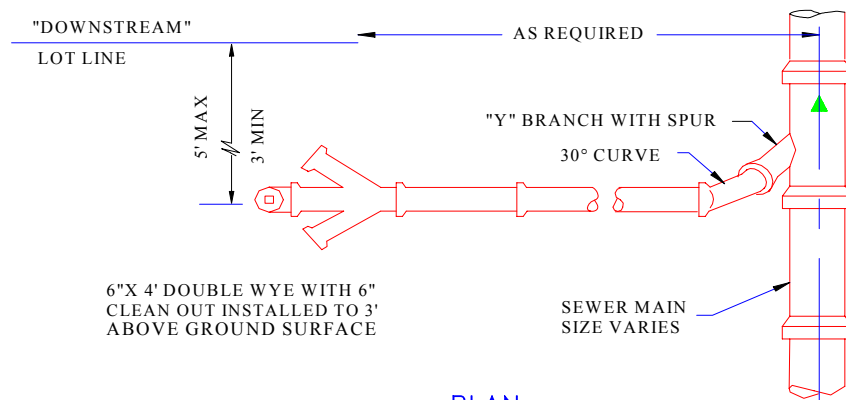

PLAN

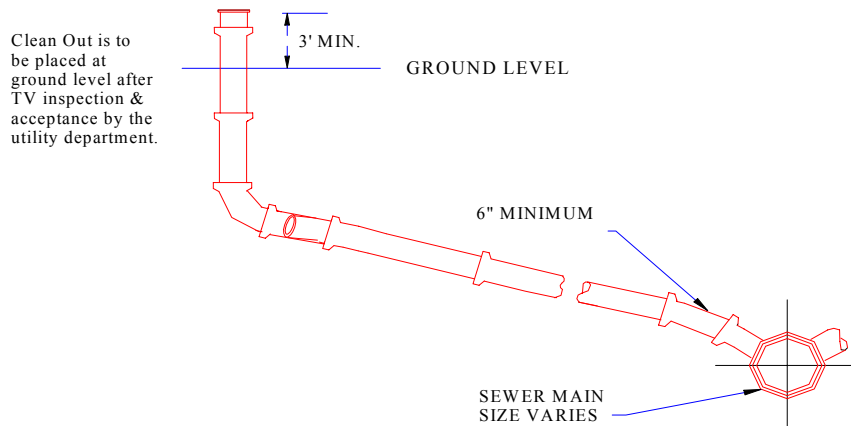

NOTE:
 SERVICE CONNECTION DETAILS
 SHOWN IS FOR A DOUBLE PVC
 SERVICE A SINGLE WYE WOULD
 BE USED FOR A SINGLE SERVICE

PROFILE

SEWER LATERAL DETAIL

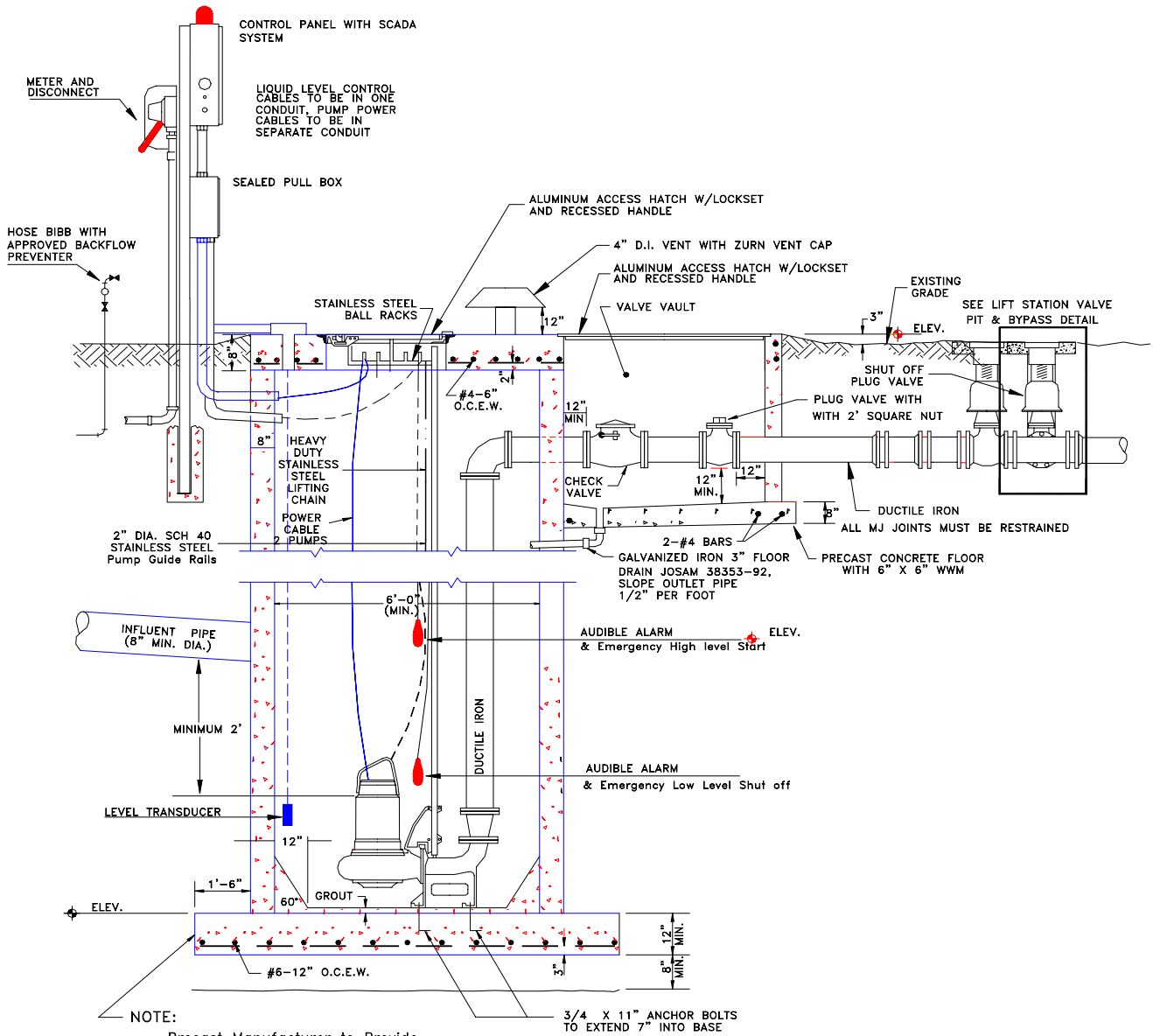

NOTE:
 Precast Manufacturer to Provide Additional Concrete in Slab AS Required to Compensate for Buoyancy of Wet Well.
 Apply Coal Tar Epoxy to Interior of Wet Well

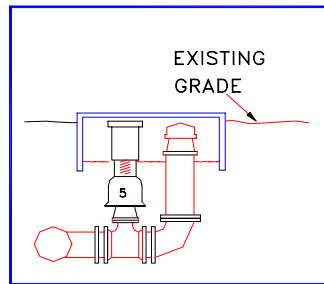
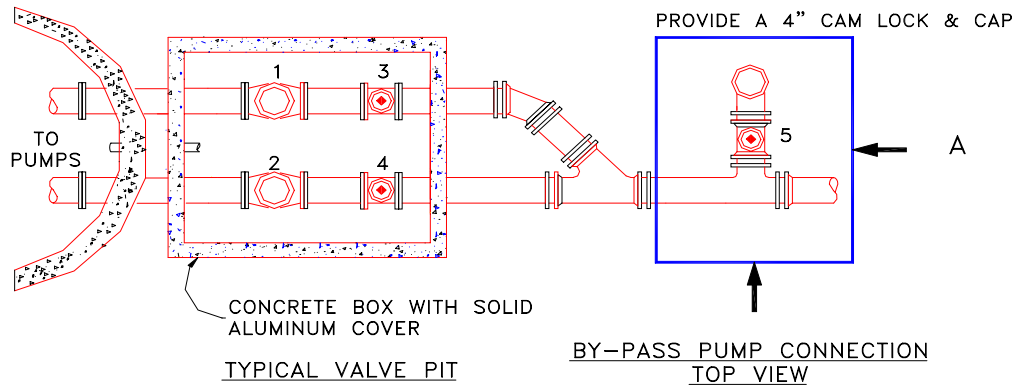

BY-PASS PUMP CONNECTION
SIDE VIEW "A"

NOTES:

1. 1 & 2 ARE CHECK VALVES
2. 3, 4, & 5 ARE PLUG VALVES
3. VALVE BOX SHALL BE INSTALLED AND ADJUSTED AT GRADE AND SHALL HAVE CONCRETE COLLAR 18" X 18" X 4" REBAR
4. MJ JOINTS ARE TO BE RESTRAINED WITH GRIP RING OR MEG A LUG RESTRAINTS

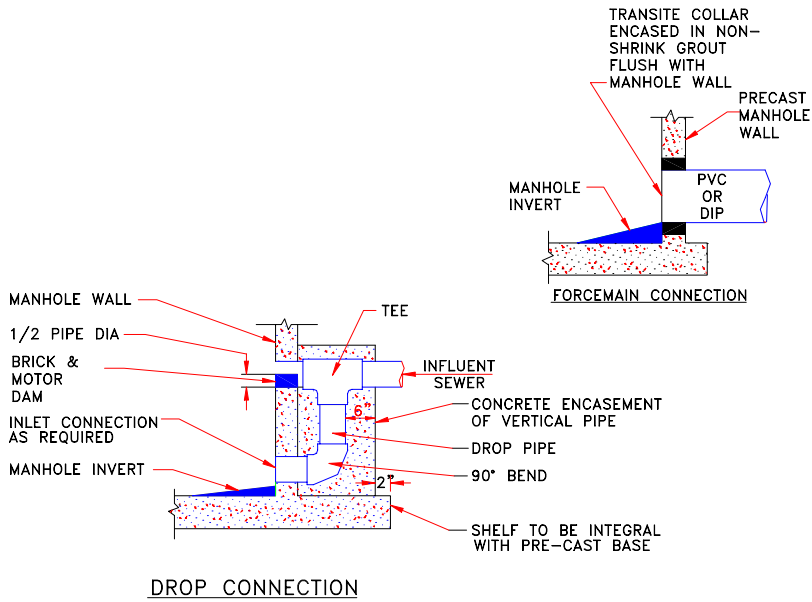

NOTES:

1. PENETRATION TO EXISTING MANHOLES SHALL BE CORE BORED
2. OUTSIDE DROP CONNECTION SHALL BE REQUIRED WHENEVER AN INFLUENT SEWER IS LOCATED TWO FEET OR MORE ABOVE THE MAIN INVERT CHANNEL

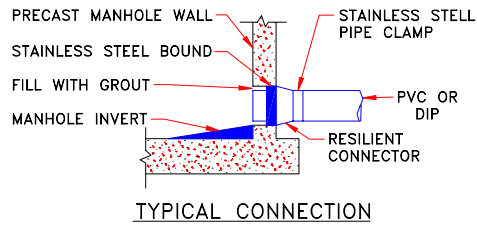

TYPICAL MANHOLE CONNECTIONS W.S. Detail 6-9-00